

Technical Data

Sx1310 / Sx1319 / Sx1510 / Sx1519 Series

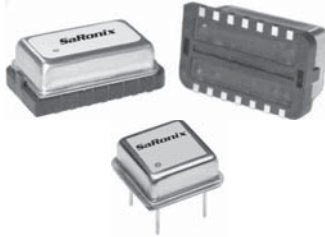

Description

A voltage controlled crystal oscillator with a wide range of performance options to 125 MHz. The devices are packaged in either standard 14-pin or 8-pin DIP compatible all metal, resistance welded packages for commercial or industrial temperature range applications. True SMD DIL14 versions for IR reflow are available, select option "S" in part number builder. See separate data sheet for SMD package dimensions.

Applications & Features

- Phase-locked loops encountered in Telecom, LAN and Wireless data, and in video processing applications
- LVCMOS, LVTTL compatible
- ~ Tri-state option available

Output Waveform

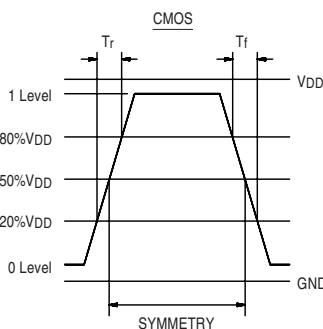

Frequency Range:	32 MHz to 125 MHz
Frequency Stability:	±25 or ±50 ppm over all conditions: operating temperature, voltage change, load change, calibration tolerance, with VC = 2.5V @ 5V, VC = 1.65V @ 3.3V
Aging:	@ 40°C: ±10 ppm max for 5 years or ±12 ppm max for 10 years
Temperature Range:	Operating: 0 to +70°C or -40 to +85°C Storage: -55 to +125°C
Supply Voltage:	Recommended Operating: 5V ±5% or 3.3V ±10%
Supply Current:	32 to 70 MHz: 50mA max, 35mA max @ 3.3V 70+ to 125 MHz: 65mA max, 35mA max @ 3.3V
Output Drive:	Symmetry: 3.3V: 45/55% max @ 50% VDD for 0 to 70°C, 3.3V: 40/60% max @ 50% VDD for -40 to +85°C 5.0V: 45/55% max @ 50% VDD or 40/60% max @ 1.4V TTL level Rise & Fall Times: 4ns max: 20% to 80% VDD 1.5ns max: 0.5V to 2.5V @ 5V TTL only 0.5V max @ 5V or 20% VDD max @ 3.3V Logic 0: 2.5V min @ 5V or 80% VDD min @ 3.3V Logic 1: 5V: 5TTL or 50pF, 32 to 50 MHz 5V: 5TTL or 30pF 50+ to 125 MHz 3.3V: 30pF up to 80 MHz, 95Ω AC up to 125 MHz Jitter: 20ps max RMS period jitter
Pull Characteristics:	Input Impedance: 50KΩ min Frequency Response (-3dB): 50 kHz min Pullability: ±25, ±50, ±75, ±100 ppm APR* Control Voltage: 0.5 to 4.5V @ 5V or 0.3 to 3.0V @ 3.3V Transfer Function: Frequency increases when Control Voltage increases Linearity: 5% or 10% max Center Control Voltage: 2.5V @ 5V, 1.65V @ 3.3V
Phase noise:	-95 dbc typ / Hz @ 100Hz -110 dbc typ / Hz @ 1kHz -100 dbc typ / Hz @ 10kHz
Mechanical:	Shock: MIL-STD-883, Method 2002, Condition B Solderability: MIL-STD-883, Method 2003 Terminal Strength: MIL-STD-202, Method 211, Conditions B2 Vibration: MIL-STD-883, Method 2007, Condition A Solvent Resistance: MIL-STD-202, Method 215 Resistance to Soldering Heat: MIL-STD-202, Method 210, Condition A, B or C (I or J for Gull Wing)
Environmental:	Gross Leak Test: MIL-STD-883, Method 1014, Condition C Fine Leak Test: MIL-STD-883, Method 1014, Condition A2 Thermal Shock: MIL-STD-883, Method 1011, Condition A Moisture Resistance: MIL-STD-883, Method 1004

* APR = (VCXO Pull relative to specified Output Frequency) – (VCXO Frequency Stability)
NOTE: APR is inclusive of Aging

Technical Data

Sx1310 / Sx1319 / Sx1510 / Sx1519 Series

Package Details

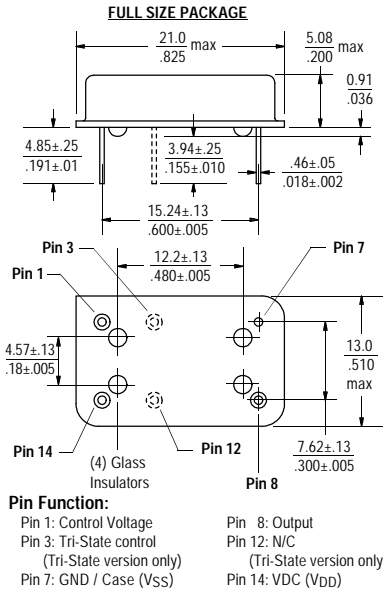

Standard Marking Format

Includes Date Code, Frequency & Part Number

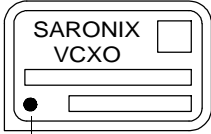

Denotes Pin 1

HALF SIZE PACKAGE

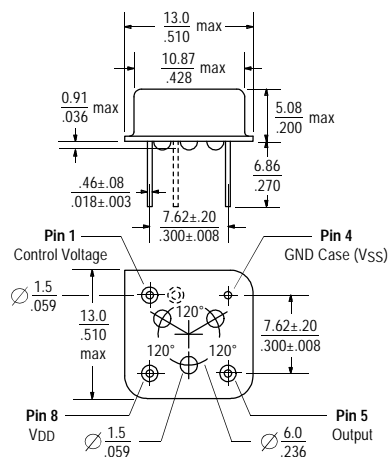

Standard Marking Format

Includes Date Code, Frequency & Part Number



Denotes Pin 1

Scale: None (Dimensions in mm/inches)

Part Numbering Guide

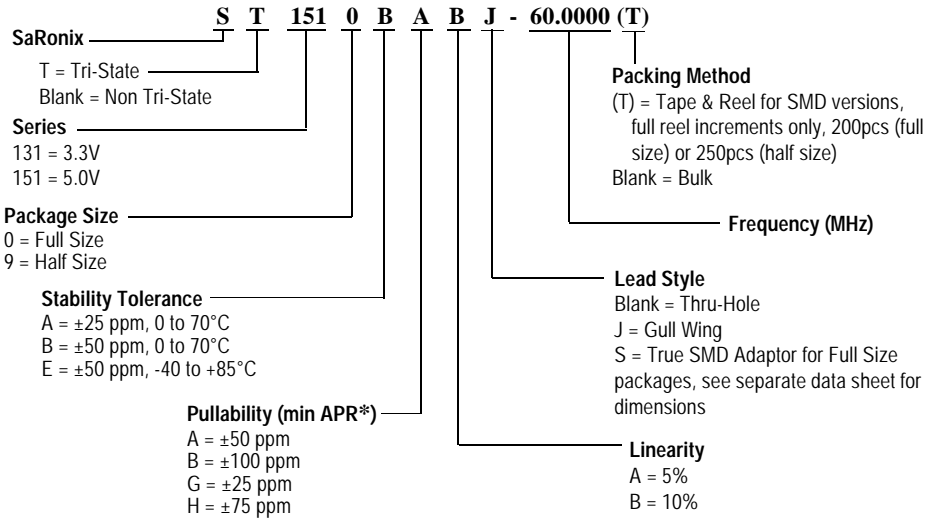

* APR = (VCXO Pull relative to specified Output Frequency) – (VCXO Frequency Stability)

NOTE: APR is inclusive of Aging

Tri-State Logic Table

Pin 3 Input	Pin 8 Output
Logic 1 or NC	Oscillation
Logic 0 or GND	High Impedance

Required Input Levels on Pin 3:

Logic 1 = 3.0V min
 Logic 0 = 0.3V max

Test Circuits

Figure 1
30pF or 50pF Load

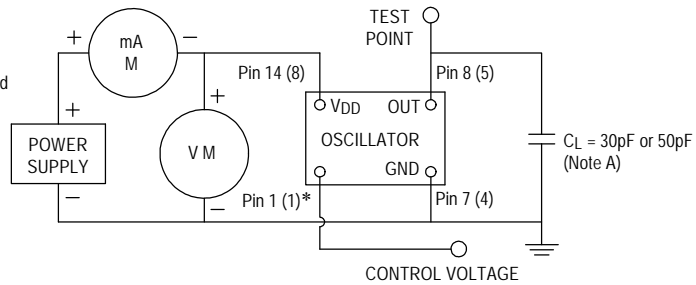
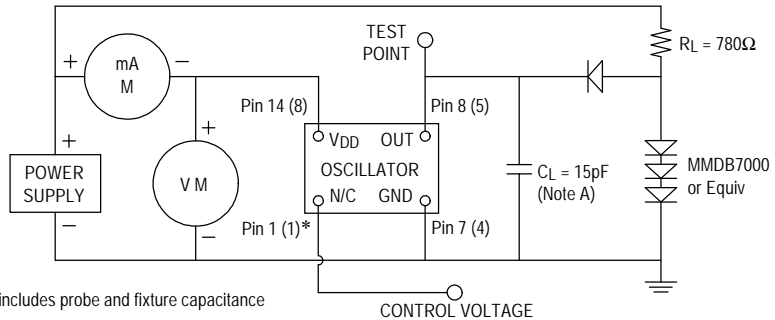

Figure 2
TTL Load



NOTE A: CL includes probe and fixture capacitance

*() Indicates pin numbers for half size package

All specifications are subject to change without notice.

DS-162 REV E

True SMD Adaptor - 7.57mm High

Technical Data

