



**Features**

- 8kV Robust ESD Protection at Antenna Port
- Enhanced Performance Transmit Module
- No External Routing
- High Efficiency at rated  $P_{OUT}$   
 $V_{BATT}=3.5V$   
GSM900 41%  
DCS1800 40%
- Low RX Insertion Loss
- Symmetrical RX Ports
- One High Linearity TX/RX WCDMA Port
- 0dBm to 6dBm Drive Level, >50dB of Dynamic Range
- Integrated Power Flattening Circuit
- $V_{BATT}$  Tracking Circuit

**Applications**

- 3V Multimode Mobile Applications
- GPRS Class 12 Compliant
- Portable Battery-Powered Equipment

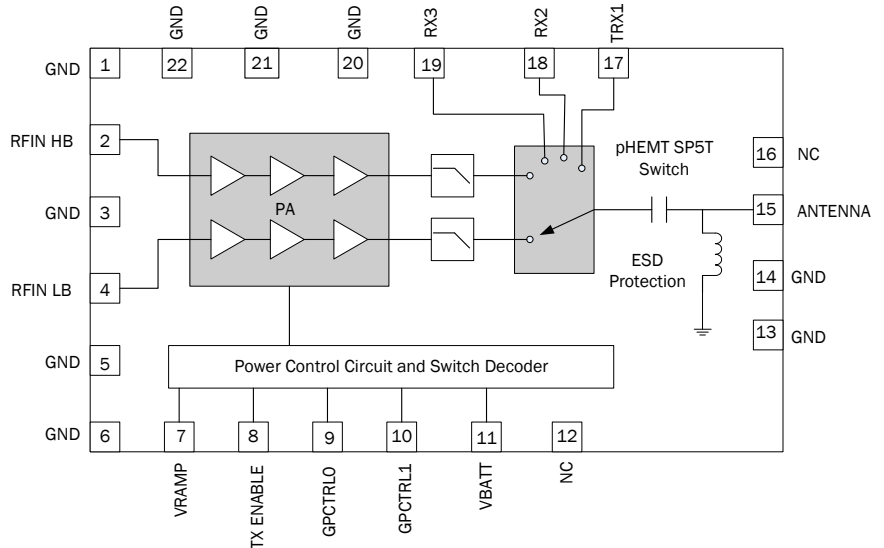

Functional Block Diagram

**Product Description**

The RF3231 is a dual band (EGSM900/DCS1800) GSM/GPRS Class 12 compliant transmit module with two symmetrical receive ports and one high linearity WCDMA port. This transmit module builds upon RFMD's leading power amplifier with PowerStar® integrated power control technology, pHEMT switch technology, and integrated transmit filtering for best-in-class harmonic performance. The results are high performance, reduced solution size, and ease of implementation. The device is designed for use as the final portion of the transmitter section in a GSM900/DCS1800/WCDMA handset and eliminates the need for a PA-to-antenna switch module matching network. The device provides 50Ω matched input and output ports requiring no external matching components.

The RF3231 features RFMD's latest integrated power-flattening circuit, which significantly reduces current and power variation into load mismatch. Additionally, a  $V_{BATT}$  tracking feature is incorporated to maintain switching performance as supply voltage decreases. The RF3231 also integrates an ESD filter to provide excellent ESD protection at the antenna port. The RF3231 is designed to provide maximum efficiency at rated  $P_{OUT}$ .

RF3231	Dual-Band GSM900/DCS1800 Transmit Module with WCDMA Port
RF3231SB	Transmit Module 5-Piece Sample Pack
RF3231PCBA-41X	Fully Assembled Evaluation Board

**Optimum Technology Matching® Applied**

- |  |                                      |  |                                   |
|--|--------------------------------------|--|-----------------------------------|
| <input checked="" type="checkbox"/> GaAs HBT | <input type="checkbox"/> SiGe BiCMOS | <input checked="" type="checkbox"/> GaAs pHEMT | <input type="checkbox"/> GaN HEMT |
| <input type="checkbox"/> GaAs MESFET         | <input type="checkbox"/> Si BiCMOS   | <input checked="" type="checkbox"/> Si CMOS    | <input type="checkbox"/> RF MEMS  |
| <input type="checkbox"/> InGaP HBT           | <input type="checkbox"/> SiGe HBT    | <input type="checkbox"/> Si BJT                | <input type="checkbox"/> LDMOS    |

RF MICRO DEVICES®, RFMD®, Optimum Technology Matching®, Enabling Wireless Connectivity™, PowerStar®, POLARIS™ TOTAL RADIO™ and UltimateBlue™ are trademarks of RFMD, LLC. BLUETOOTH is a trademark owned by Bluetooth SIG, Inc., U.S.A. and licensed for use by RFMD. All other trade names, trademarks and registered trademarks are the property of their respective owners. ©2006, RF Micro Devices, Inc.

## Absolute Maximum Ratings

Parameter	Rating	Unit
Supply Voltage	-0.3 to +6.0	V
Power Control Voltage ( $V_{RAMP}$ )	-0.3 to +1.8	V
Input RF Power	+10	dBm
Max Duty Cycle	50	%
Output Load VSWR	20:1	
Operating Temperature	-30 to +85	°C
Storage Temperature	-55 to +150	°C



Caution! ESD sensitive device.

Exceeding any one or a combination of the Absolute Maximum Rating conditions may cause permanent damage to the device. Extended application of Absolute Maximum Rating conditions to the device may reduce device reliability. Specified typical performance or functional operation of the device under Absolute Maximum Rating conditions is not implied.

RoHS status based on EUDirective2002/95/EC (at time of this document revision).

The information in this publication is believed to be accurate and reliable. However, no responsibility is assumed by RF Micro Devices, Inc. ("RFMD") for its use, nor for any infringement of patents, or other rights of third parties, resulting from its use. No license is granted by implication or otherwise under any patent or patent rights of RFMD. RFMD reserves the right to change component circuitry, recommended application circuitry and specifications at any time without prior notice.

Parameter	Specification			Unit	Condition
	Min.	Typ.	Max.		
<b>ESD</b>					
ESD RF Ports			1000	V	HBM, JESD22-A114
			1000	V	CDM, JEDEC JESD22-C101
ESD Antenna Port			8	KV	IEC 61000-4-2
ESD Any Other Port			1000	V	HBM, JESD22-A114
			1000	V	CDM, JEDEC JESD22-C101
<b>Overall Power Control <math>V_{RAMP}</math></b>					
Power Control "ON"			1.8	V	Max. $P_{OUT}$
Power Control "OFF"		0.25		V	Min. $P_{OUT}$
$V_{RAMP}$ Input Capacitance			20	pF	DC to 200kHz
$V_{RAMP}$ Input Current			10	$\mu$ A	
Power Control Range		50		dB	$V_{RAMP} = 0.25V$ to $V_{RAMP MAX}$
<b>Overall Power Supply</b>					
Power Supply Voltage	3.1	3.5	4.8	V	Operating Limits
Power Supply Current		1	20	$\mu$ A	$P_{IN} < -30dBm$ , TX Enable = Low, $V_{RAMP} = 0.25V$ , Temp = $-20^{\circ}C$ to $+85^{\circ}C$ , $V_{BATT} = 4.8V$
<b>Overall Control Signals</b>					
GpCtrl0, GpCtrl1 "Low"	0	0	0.5	V	
GpCtrl0, GpCtrl1 "High"	1.25	2.0	3.0	V	
GpCtrl0, GpCtrl1 "High Current"		1	2	$\mu$ A	
TX Enable "Low"	0	0	0.5	V	
TX Enable "High"	1.25	2.0	3.0	V	
TX Enable "High Current"		1	2	$\mu$ A	
RF Port Input and Output Impedance		50		$\Omega$	

TX ENABLE	GpCtrl1	GpCtrl0	TX Module Mode
0	0	0	Low Power Mode (Stand-by)
0	0	1	TRX1
0	1	1	RX2
0	1	0	RX3
1	1	0	GSM900 TX Mode
1	1	1	DCS1800 TX Mode

Parameter	Specification			Unit	Condition
	Min.	Typ.	Max.		
<b>GSM900 Band</b>					Nominal conditions unless otherwise stated. $V_{BATT}=3.5V$ , $P_{IN}=3dBm$ , Temp= $+25^{\circ}C$ , TX Enable=High, $V_{RAMP}=1.8V$ TX Mode: GpCtrl1=High, GpCtrl0=Low, Duty Cycle=25%, Pulse Width=1154 $\mu s$
Operating Frequency Range	880		915	MHz	
Input Power	0	3	6	dBm	Full $P_{OUT}$ guaranteed at minimum drive level.
Input VSWR			2.5:1		$5dBm \leq P_{OUT} \leq 33dBm$
Maximum Output Power	33.0	33.8		dBm	$V_{RAMP}=1.8V$ ; $P_{IN}=0dBm$
	31.0			dBm	$V_{BATT}=3.1V$ to 4.8V, Temp= $-20^{\circ}C$ to $85^{\circ}C$ , $P_{IN}=0dBm$ to 6dBm, $V_{RAMP}=1.8V$
	30.0			dBm	VSWR=3:1; $P_{OUT}=33dBm$ at Save State*; Delivered $P_{OUT}$
Efficiency		44		%	$V_{RAMP}=1.8V$
		41		%	$P_{OUT}=33dBm$
$V_{BATT}$ Current		1390		mA	$P_{OUT}=33dBm$
		80		mA	$P_{OUT}=5dBm$
			1900	mA	VSWR=3:1; $P_{OUT}=33dBm$ at Save State*
Forward Isolation		-54	-41	dBm	$P_{IN}=6dBm$ , TxEnable="Low"
		-28	-10	dBm	$P_{IN}=6dBm$ , TxEnable="High"; $V_{RAMP}=0.25V$
2nd Harmonic		-40	-33	dBm	$P_{OUT}=33dBm$
3rd Harmonic		-40	-33	dBm	$P_{OUT}=33dBm$
4th Harmonic to 12.75GHz			-33	dBm	$P_{OUT}=33dBm$
RX Band Noise Power		-83	-77	dBm	$P_{OUT}=33dBm$ ; $P_{IN}=0dBm$ ; 925MHz to 935MHz
		-87	-83	dBm	$P_{OUT}=33dBm$ ; $P_{IN}=0dBm$ ; 935MHz to 960MHz
		-115	-87	dBm	$P_{OUT}=33dBm$ ; $P_{IN}=0dBm$ ; 1850MHz to 1880MHz
Power Control Accuracy					$V_{BATT}=3.1V$ to 4.8V, Temp= $-20^{\circ}C$ to $85^{\circ}C$ , $P_{IN}=0dBm$ to 6dBm
		$\pm 1$	$\pm 3$	dB	$P_{OUT}=5dBm$ to 11dBm at Save State*
		$\pm 1$	$\pm 3$	dB	$P_{OUT}=13dBm$ to 31dBm at Save State*
		$\pm 1.5$	$\pm 2$	dB	$P_{OUT}=33dBm$ at Save State*
Stability			-36	dBm	VSWR=12:1; $5dBm \leq P_{OUT} \leq 33dBm$ at Save State*; $V_{BATT}=3.1V$ to 4.8V; Temp= $-10^{\circ}C$ to $85^{\circ}C$ ; $P_{IN}=0dBm$ to 6dBm; No parasitic oscillations
Ruggedness	No damage or permanent degradation to device				VSWR=20:1; $5dBm \leq P_{OUT} \leq 33dBm$ at Save State*; $V_{BATT}=3.1V$ to 4.8V; Temp= $-30^{\circ}C$ to $85^{\circ}C$ ; $P_{IN}=0dBm$ to 6dBm

\*Save State:  $V_{RAMP}$  is set to desired  $P_{OUT}$  at nominal conditions and held constant for each measurement.

Parameter	Specification			Unit	Condition
	Min.	Typ.	Max.		
<b>DCS 1800 Band</b>					Nominal conditions: unless otherwise stated. $V_{BATT}=3.5V$ , $P_{IN}=3\text{ dBm}$ , $Temp=+25^{\circ}C$ , TX Enable=High, $V_{RAMP}=1.8V$ TX Mode: GpCtrl1=High, GpCtrl0=High, Duty Cycle=25%, Pulse Width=1154 $\mu$ s
Operating Frequency Range	1710		1785	MHz	
Input Power	0	3	6	dBm	Full $P_{OUT}$ guaranteed at minimum drive level.
Input VSWR			2.5:1		$0\text{ dBm} \leq P_{OUT} \leq 30\text{ dBm}$
Maximum Output Power	30.0	31.2		dBm	$V_{RAMP}=1.8V$ ; $P_{IN}=0\text{ dBm}$
	28.0			dBm	$V_{BATT}=3.1V$ to $4.8V$ , $Temp=-20^{\circ}C$ to $85^{\circ}C$ , $P_{IN}=0\text{ dBm}$ to $6\text{ dBm}$ , $V_{RAMP}=1.8V$
	27.0			dBm	VSWR=3:1; $P_{OUT}=30\text{ dBm}$ at Save State*; Delivered $P_{OUT}$
Efficiency		42		%	$V_{RAMP}=1.8V$
		40		%	$P_{OUT}=30\text{ dBm}$
$V_{BATT}$ Current		710		mA	$P_{OUT}=30\text{ dBm}$
		45		mA	$P_{OUT}=0\text{ dBm}$
Forward Isolation		-65	-53	dBm	$P_{IN}=6\text{ dBm}$ , TxEnable="Low"
		-25	-10	dBm	$P_{IN}=6\text{ dBm}$ , TxEnable="High"; $V_{RAMP}=0.25V$
2nd Harmonic		-40	-33	dBm	$P_{OUT}=30\text{ dBm}$
3rd Harmonic		-40	-33	dBm	$P_{OUT}=30\text{ dBm}$
4th Harmonic to 12.75GHz			-33	dBm	$P_{OUT}=30\text{ dBm}$
RX Band Noise Power		-84	-80	dBm	$P_{OUT}=30\text{ dBm}$ ; $P_{IN}=0\text{ dBm}$ ; 1805 MHz to 1880MHz
		-98	-83	dBm	$P_{OUT}=30\text{ dBm}$ ; $P_{IN}=0\text{ dBm}$ ; 925 MHz to 960MHz
Power Control Accuracy					$V_{BATT}=3.1V$ to $4.8V$ , $Temp=-20^{\circ}C$ to $85^{\circ}C$ , $P_{IN}=0\text{ dBm}$ to $6\text{ dBm}$
		$\pm 1.5$	$\pm 3$	dB	$P_{OUT}=0\text{ dBm}$ to $2\text{ dBm}$ at Save State*
		$\pm 1$	$\pm 3$	dB	$P_{OUT}=4\text{ dBm}$ to $28\text{ dBm}$ at Save State*
		$\pm 1.5$	$\pm 2$	dB	$P_{OUT}=30\text{ dBm}$ at Save State*
Stability			-36	dBm	VSWR=12:1; $0\text{ dBm} \leq P_{OUT} \leq 30\text{ dBm}$ at Save State*; $V_{BATT}=3.1V$ to $4.8V$ , $Temp=-10^{\circ}C$ to $85^{\circ}C$ , $P_{IN}=0\text{ dBm}$ to $6\text{ dBm}$ ; No parasitic oscillations
Ruggedness	No damage or permanent degradation to device				VSWR=20:1; $0\text{ dBm} \leq P_{OUT} \leq 30\text{ dBm}$ at Save State*; $V_{BATT}=3.1V$ to $4.8V$ ; $Temp=-30^{\circ}C$ to $85^{\circ}C$ ; $P_{IN}=0\text{ dBm}$ to $6\text{ dBm}$

\*Save State:  $V_{RAMP}$  is set to desired  $P_{OUT}$  at nominal conditions and held constant for each measurement.

Parameter	Specification			Unit	Condition
	Min.	Typ.	Max.		
<b>RX Section</b>					Nominal conditions unless otherwise stated. $V_{BATT}=3.5V$ , Temp=25°C. TX Enable=Low; TRX1 Mode: GpCtrl1=Low, GpCtrl0=High RX2 Mode: GpCtrl1=High, GpCtrl0=High RX3 Mode: GpCtrl1=High, GpCtrl0=Low
TRX1 Insertion Loss		0.8	1.1	dB	Freq=1920MHz to 2170MHz. See Note 1.
TRX1 Inband Ripple		0.2		dB	Freq=1920MHz to 2170MHz
TRX1 Input VSWR			1.5:1		Freq=1920MHz to 2170MHz
TRX1 Isolation to RX2/RX3	20	30		dB	Freq=1920MHz to 2170MHz
TRX1 IMD2		-105	-100	dBm	IM Freq=2140MHz; TX Freq=1950MHz at 20dBm; Blocker Freq=190MHz, 4090MHz at -15dBm
TRX1 IMD3		-115	-105	dBm	IM Freq=2140MHz; TX Freq=1950MHz at 20dBm; Blocker Freq=1760MHz at -15dBm
RX2/RX3 Insertion Loss		0.9	1.3	dB	Freq=925MHz to 960MHz. See Note 1.
		1.2	1.6	dB	Freq=1805MHz to 1880MHz. See Note 1.
RX2/RX3 In-band Ripple		0.2		dB	Freq=925MHz to 960MHz
		0.2		dB	Freq=1805MHz to 1880MHz
RX2/RX3 Input VSWR			1.8:1		Freq=925MHz to 1880MHz
<b>TX Section</b>					
GSM900 TX Leakage to RX Ports		-5	8	dBm	Nominal Conditions ; $P_{OUT}=33dBm$ ; Measure TRX1, RX2, and RX3. See Note 2.
DCS1800 TX Leakage to RX Ports		-5	6	dBm	Nominal Conditions ; $P_{OUT}=30dBm$ ; Measure TRX1, RX2, and RX3. See Note 2.

Note 1: The insertion loss values listed are the values guaranteed at the DUT port reference plane (i.e. excludes external mismatch and resistive trace losses).

Note 2: Isolation specification set to ensure at least the following isolation rated power:

Calculation Example using typical values:  $P_{OUT}$  at Antenna -  $P_{OUT}$  at RX Port, Isolation  $LB=33-(-5)=38dB$ ,  $HB=30-(-5)=35dB$ .

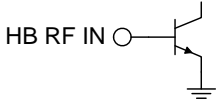
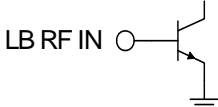
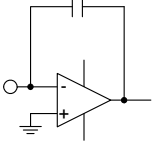
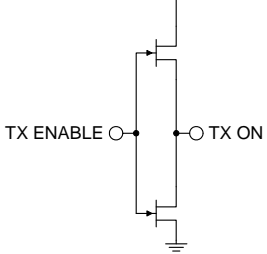
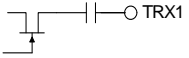
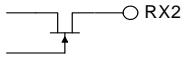
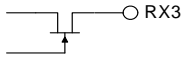
Pin	Function	Description	Interface Schematic
1	GND		
2	RFIN HB	RF input to the DCS1800 band. This is a 50Ω input.	
3	GND		
4	RFIN LB	RF input to the GSM900 band. This is a 50Ω input.	
5	GND		
6	GND		
7	VRAMP	V <sub>RAMP</sub> ramping signal from DAC. A simple RC filter is integrated into the RF3231 module. V <sub>RAMP</sub> may or may not require additional filtering depending on the baseband selected.	
8	TX ENABLE	This signal enables the PA module for operation with a logic high. The switch is put in TX mode determined by GpCtrl0 and GpCtrl1.	
9	GPCTRL0	Control pin that together with GpCtrl1 selects band of operation.	
10	GPCTRL1	Control pin that together with GpCtrl0 selects band of operation.	
11	VBATT	Power supply for the module. This should be connected to the battery terminal using as wide a trace as possible.	
12	NC		
13	GND		
14	GND		
15	ANTENNA	Antenna port.	
16	NC		
17	TRX1	TRX1 WCDMA port of antenna switch. This is a 50Ω input/output.	
18	RX2	RX2 port of antenna switch. This is a 50Ω output. RX2 is interchangeable with RX3.	
19	RX3	RX3 port of antenna switch. This is a 50Ω output. RX3 is interchangeable with RX2.	
20	GND		
21	GND		
22	GND		
23	GND		

**Pin Out**  
(Top View)

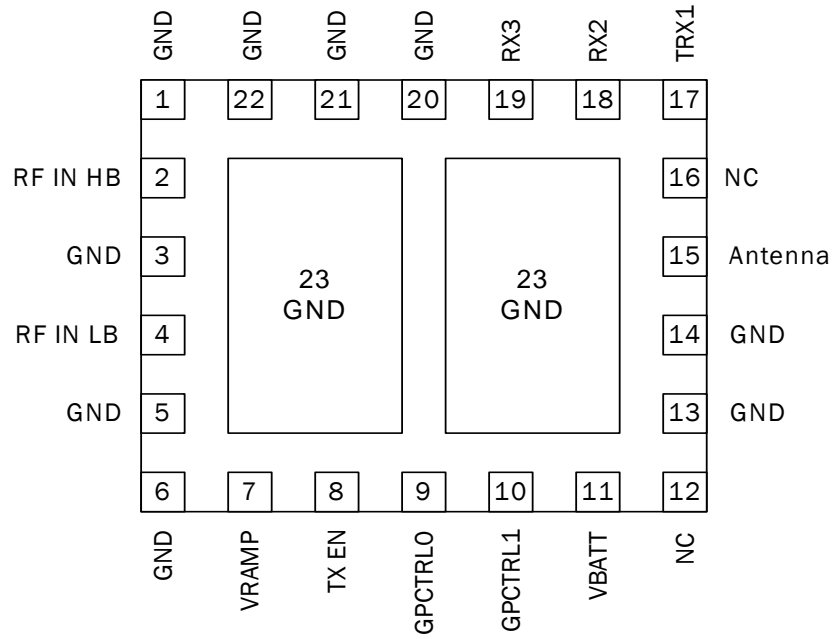

## Theory of Operation

### Product Description

The RF3231 is a dual-band, transmit module (TXM) with fully-integrated power control functionality, harmonic filtering, band selectivity, and TX/RX switching. The TXM is self-contained, having 50Ω I/O terminals, one high-linearity WCDMA port, and two symmetrical RX ports allowing multi-band operation. The power control function eliminates all power control circuitry, including directional couplers, diode detectors, and power control ASICs, etc. The power control capability provides 50dB of continuous control range and 70dB of total control range, using a DAC-compatible, analog voltage input. The TX Enable feature provides for PA activation (TX mode) or RX mode/standby. Internal switching provides a low-loss, low-distortion path from the antenna port to the TX path (or RX port), while maintaining proper isolation. Integrated filtering provides ETSI-compliant harmonic suppression at the antenna port even under high mismatch conditions, which is important as modern antennas often present a load that significantly deviates from nominal impedance.

### Overview

The RF3231 simplifies the phone design by eliminating the need for the complicated control loop, harmonic filters, and TX/RX switch along with their associated matching components. The power control loop can be driven directly from the DAC output in the baseband circuit. The module has two RX ports for EGSM900 and DCS1800 bands of operation and one WCDMA port for multi-mode operation. The 2 RX ports are symmetrical, they can be used either as EGSM900 or DCS1800. To control the mode of operation, there are three logic control signals: TX Enable, GpCtrl0, and GpCtrl1. RF3231 offers high efficiency at the rated P<sub>OUT</sub> as backed-off efficiency is improved in this TXM.

### Power On Sequence

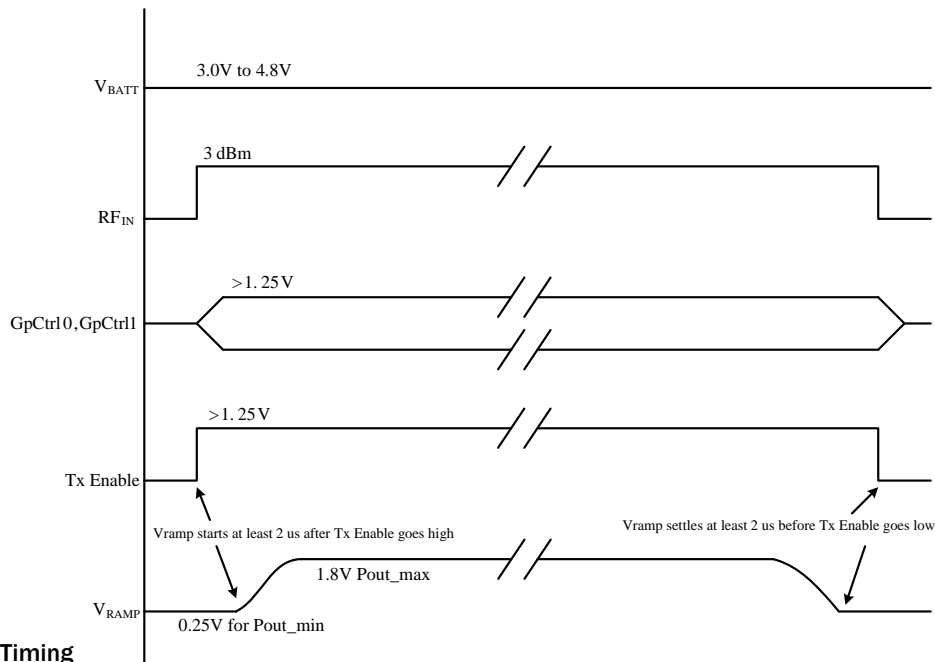

Figure 1. Timing

1. Apply V<sub>BATT</sub>
2. Apply GpCtrl0, GpCtrl1, RFIN and TX Enable
3. Apply V<sub>RAMP</sub> at least 2 μs after TX Enable
4. The Power Down Sequence is in opposite order of the Power On Sequence

The RF3231 has an integrated power flattening circuit that reduces the amount of current variation when a mismatch is presented to the output of the PA. When a mismatch is presented to the output of the PA, its output impedance is varied and could present a load that will increase output power. As the output power increases, so does current consumption. The current con-

sumption can become very high if not monitored and limited. The power flattening circuit is integrated onto the CMOS controller and requires no input from the user.

Into a mismatch, the current varies as the phase changes. The power flattening circuit monitors current through an internal sense resistor. As the current changes, the loop is adjusted in order to maintain current. The result is flatter power and reduced current into mismatch.

The RF3231 also incorporates a  $V_{BATT}$  tracking feature that eliminates the need for the transceiver/baseband to regulate the ramping signal as the supply voltage decreases. The internal circuit monitors the supply voltage and adjusts the ramping signal such that the switching spectrum is minimally impacted.

## Application Schematic

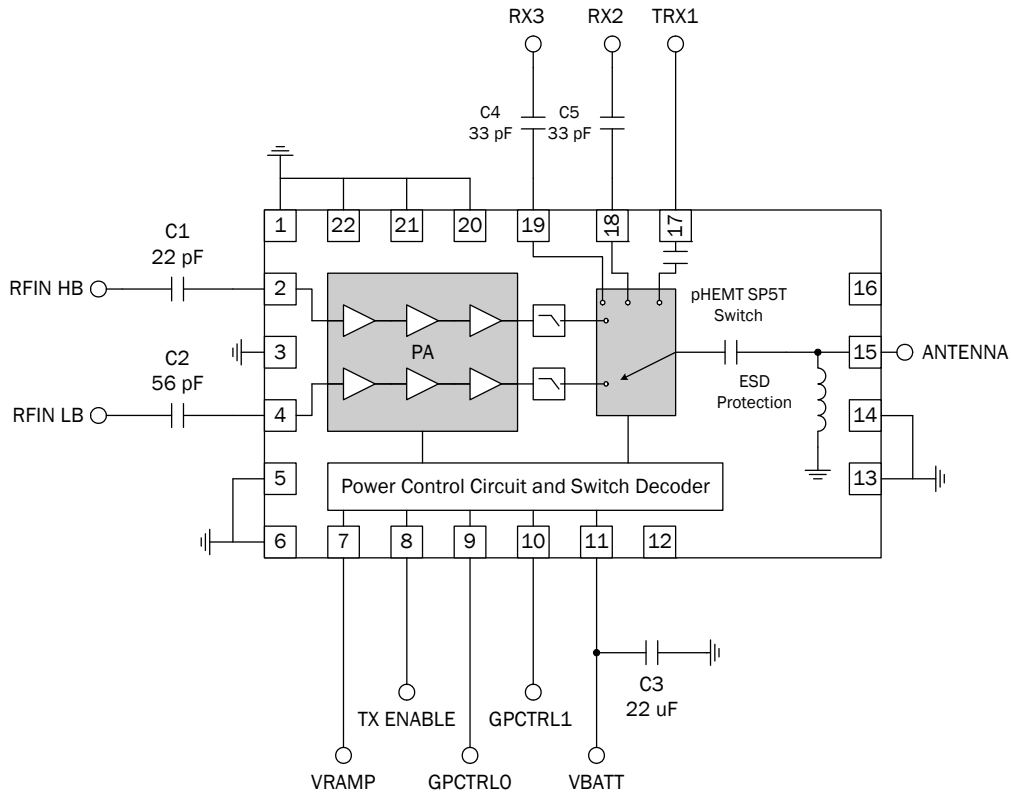

- \*All inputs, outputs, and antenna traces are 50  $\Omega$  micro strip.
- \*\* $V_{BATT}$  capacitor value may change depending on application.
- \*\*\*Since RX2 and RX3 contain a DC-bias voltage, it is essential to place a DC-blocking capacitor on these lines to avoid unpredictable behavior.
- \*\*\*\*If placing an attenuation network on the input to the power amplifier, ensure that it is positioned on the transceiver side of capacitor C1 (or C2) to prevent adversely affecting the base biasing of the power amplifier.

### Evaluation Board Schematic

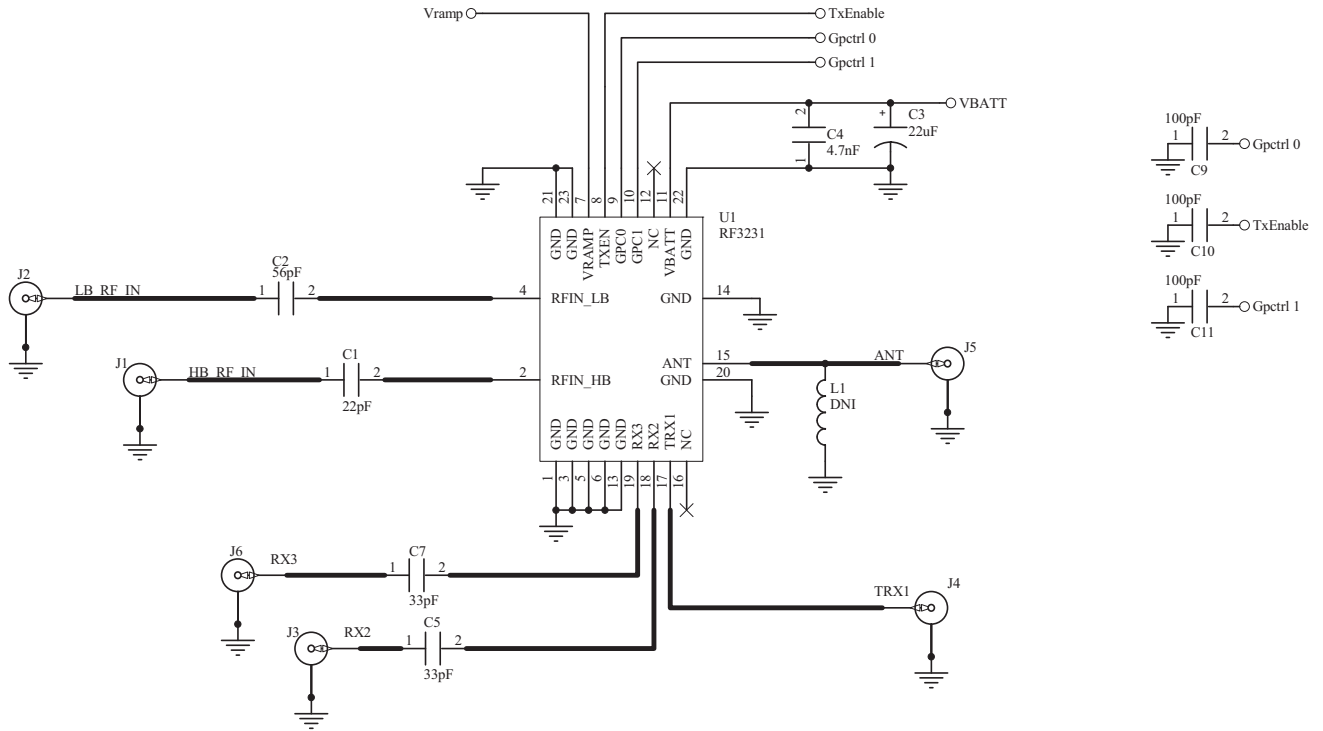

## Evaluation Board Layout

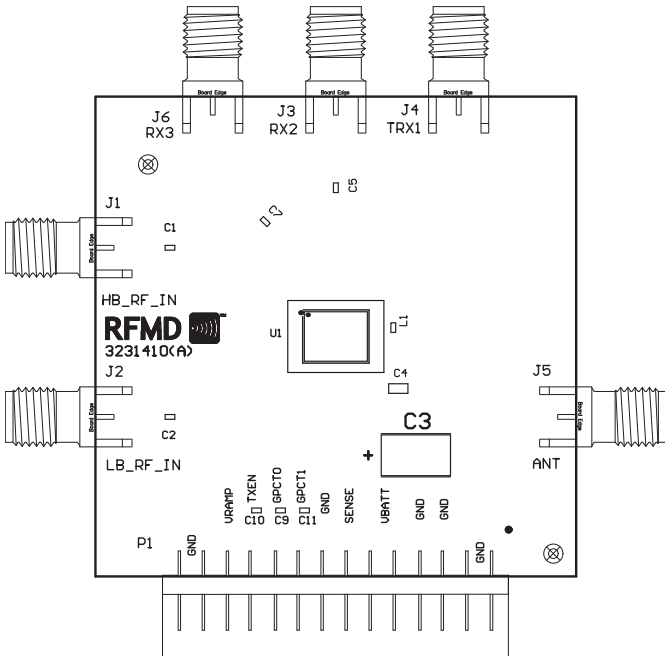

**Package Drawing**

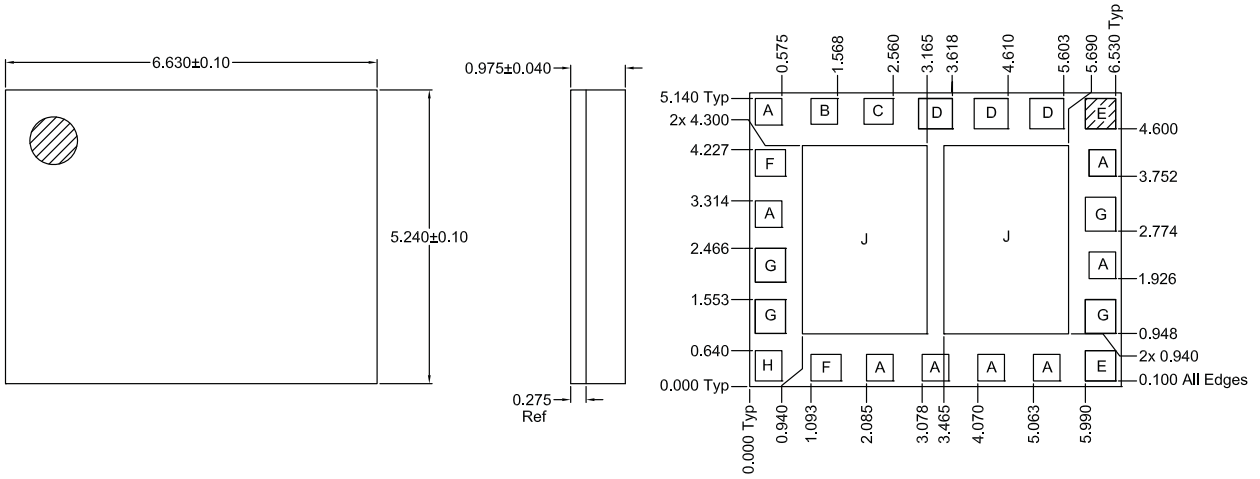

**Notes:**

- 1. Shaded area represents Pin 1 location

- A = 0.475 mm Sq Typ
- B = 0.475 x 0.460 mm
- C = 0.520 x 0.460 mm
- D = 0.605 x 0.540 mm Typ
- E = 0.540 mm Sq
- F = 0.540 x 0.475 mm
- G = 0.540 x 0.605 mm Typ
- H = 0.475 x 0.540 mm
- J = 2.225 x 3.360 mm Typ

## PCB Design Requirements

### PCB Surface Finish

The PCB surface finish used for RFMD's qualification process is electroless nickel, immersion gold. Typical thickness is 3µinch to 8µinch gold over 180µinch nickel.

### PCB Land Pattern Recommendation

PCB land patterns for RFMD components are based on IPC-7351 standards and RFMD empirical data. The pad pattern shown has been developed and tested for optimized assembly at RFMD. The PCB land pattern has been developed to accommodate lead and package tolerances. Since surface mount processes vary from company to company, careful process development is recommended.

### PCB Metal Land and Solder Mask Pattern

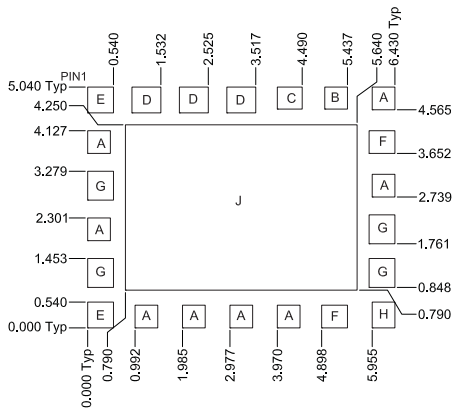

PCB METAL LAND PATTERN

- A = 0.475 mm Sq Typ
- B = 0.475 x 0.460 mm
- C = 0.520 x 0.460 mm
- D = 0.605 x 0.540 mm Typ
- E = 0.540 mm Sq
- F = 0.540 x 0.475 mm
- G = 0.540 x 0.605 mm Typ
- H = 0.475 x 0.540 mm
- J = 4.850 x 3.460 mm

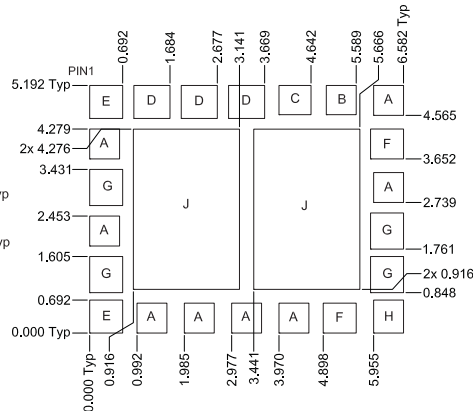

PCB SOLDER MASK PATTERN

- A = 0.627 mm Sq Typ
- B = 0.627 x 0.612 mm
- C = 0.672 x 0.612 mm Typ
- D = 0.757 x 0.692 mm Typ
- E = 0.692 mm Sq Typ
- F = 0.692 x 0.627 mm Typ
- G = 0.692 x 0.757 mm Typ
- H = 0.627 x 0.692 mm
- J = 2.225 x 3.360 mm Typ

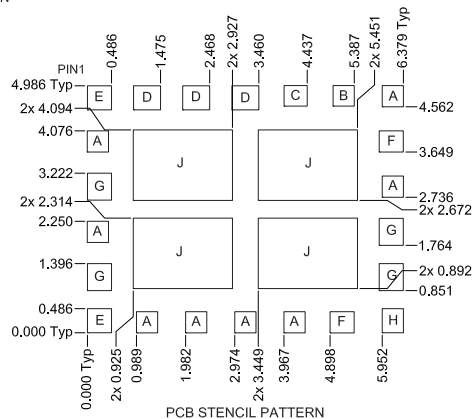

PCB STENCIL PATTERN

- A = 0.428 mm Sq Typ
- B = 0.428 x 0.414 mm
- C = 0.468 x 0.414 mm
- D = 0.544 x 0.486 mm
- E = 0.486 mm Sq
- F = 0.486 x 0.428 mm
- G = 0.486 x 0.544 mm Typ
- H = 0.428 x 0.486 mm
- J = 2.002 x 1.422 mm Typ

### Tape and Reel

Carrier tape basic dimensions are based on EIA 481. The pocket is designed to hold the part for shipping and loading onto SMT manufacturing equipment, while protecting the body and the solder terminals from damaging stresses. The individual pocket design can vary from vendor to vendor, but width and pitch will be consistent.

Carrier tape is wound or placed onto a shipping reel either 330mm (13 inches) in diameter or 178mm (7 inches) in diameter. The center hub design is large enough to ensure the radius formed by the carrier tape around it does not put unnecessary stress on the parts.

Prior to shipping, moisture sensitive parts (MSL level 2a-5a) are baked and placed into the pockets of the carrier tape. A cover tape is sealed over the top of the entire length of the carrier tape. The reel is sealed in a moisture barrier ESD bag with the appropriate units of desiccant and a humidity indicator card, which is placed in a cardboard shipping box. It is important to note that unused moisture sensitive parts need to be resealed in the moisture barrier bag. If the reels exceed the exposure limit and need to be rebaked, most carrier tape and shipping reels are not rated as bakeable at 125 °C. If baking is required, devices may be baked according to section 4, table 4-1, of Joint Industry Standard IPC/JEDEC J-STD-033.

The table below provides information for carrier tape and reels used for shipping the devices described in this document.

#### Tape and Reel

RFMD Part Number	Reel Diameter Inch (mm)	Hub Diameter Inch (mm)	Width (mm)	Pocket Pitch (mm)	Feed	Units per Reel
<b>RF3231TR13</b>	13 (330)	4 (102)	12	8	Single	2500
<b>RF3231TR7</b>	7 (178)	2.4 (61)	12	8	Single	750

Unless otherwise specified, all dimension tolerances per EIA-481.

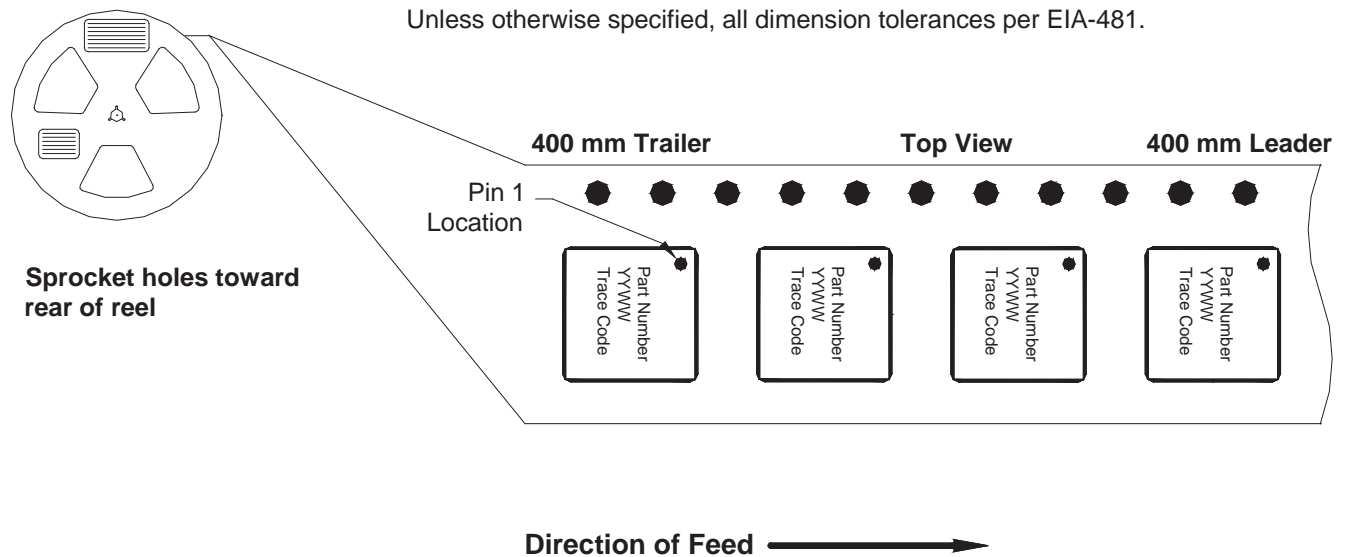

Figure 1. 5.24mmx6.63mm (Carrier Tape Drawing with Part Orientation)

## RoHS\* Banned Material Content

RoHS Compliant: Yes  
 Package total weight in grams (g): 0.121  
 Compliance Date Code: -  
 Bill of Materials Revision: -  
 Pb Free Category: e4

Bill of Materials	Parts Per Million (PPM)					
	Pb	Cd	Hg	Cr VI	PBB	PBDE
Die	0	0	0	0	0	0
Molding Compound	0	0	0	0	0	0
Lead Frame	0	0	0	0	0	0
Die Attach Epoxy	0	0	0	0	0	0
Wire	0	0	0	0	0	0
Solder Plating	0	0	0	0	0	0

This RoHS banned material content declaration was prepared solely on information, including analytical data, provided to RFMD by its suppliers, and applies to the Bill of Materials (BOM) revision noted above.

\* DIRECTIVE 2002/95/EC OF THE EUROPEAN PARLIAMENT AND OF THE COUNCIL of 27 January 2003 on the restriction of the use of certain hazardous substances in electrical and electronic equipment