



Description

The MK2751 is a low cost, low jitter, high performance clock synthesizer designed for MPEG and Set-top box systems. Using analog Phase-Locked Loop (PLL) techniques, the device accepts a 27.00MHz crystal or clock input to produce multiple output clocks including the processor clock, low skew divide by two of the processor clock, the audio processor or NTSC/PAL clock, and a selectable audio clock. The audio clocks are exactly frequency locked to the 27.00MHz input with zero ppm error, allowing audio and video to track exactly.

MicroClock manufactures the largest variety of Set-Top Box and multimedia clock synthesizers for all applications. Consult MicroClock to eliminate crystals and oscillators from your board.

Features

- Packaged in 16 pin narrow (150 mil) SOIC 
- Works well with C-Cube MPEG decoders and AuraVision video processors
- Selectable audio sampling frequencies support 32 kHz, 44.1 kHz, and 48 kHz in most DACs
- 27.00 MHz crystal or clock input
- Selectable processor frequencies of 60 or 66.0MHz and 30 or 33.0MHz
- Zero ppm error in audio clocks give highest performance audio tracking with video
- 25mA output drive capability at TTL levels
- Advanced, low power, sub-micron CMOS process
- 5V±10% operating voltage

Block Diagram

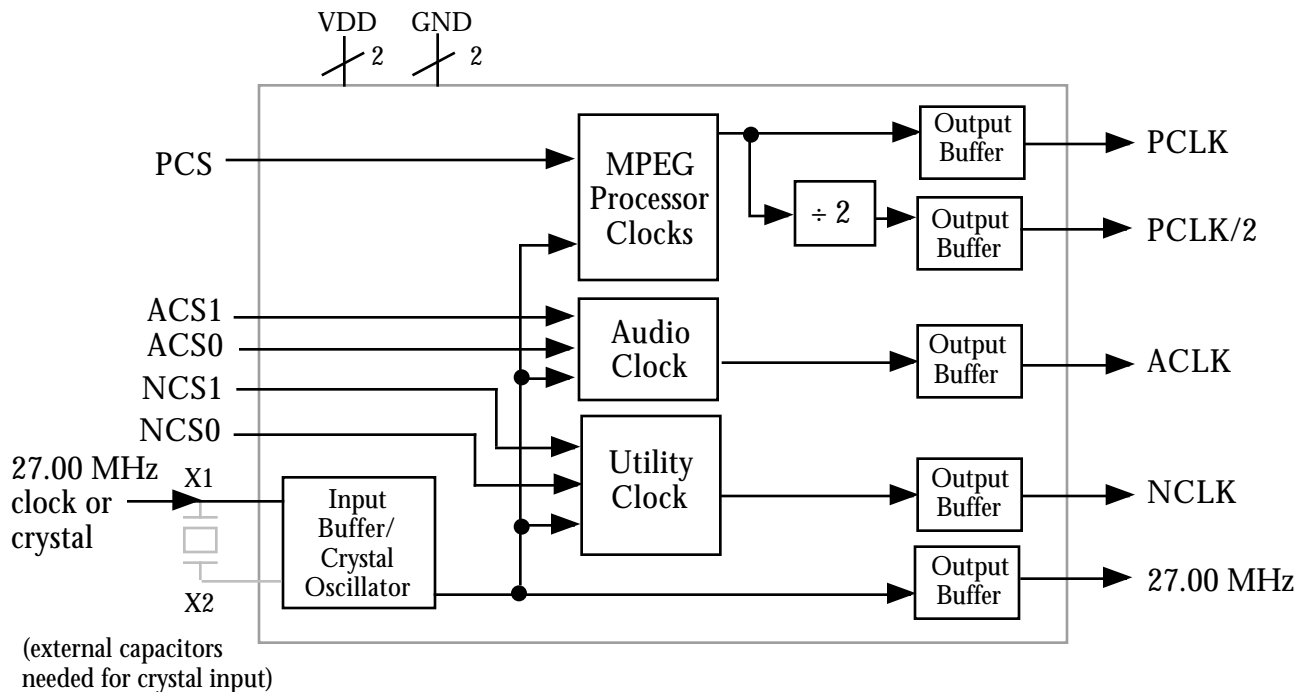



Pin Assignment

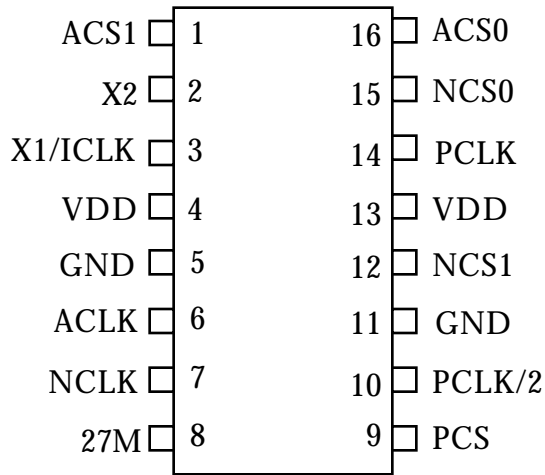

16 pin narrow (150 mil) SOIC

Audio Clock (in MHz)

ACS1	ACS0	ACLK
0	0	8.192
0	1	11.2896
1	0	12.288
1	1	16.9344

NTSC/PAL Clock

NCS1	NCS0	NCLK
0	0	28.63636
0	1	35.46895
1	0	40
1	1	24.576

Processor Clocks (in MHz)

PCS	PCLK	PCLK/2
0	60.00	30.00
1	66.00	33.00

Pin Descriptions

Number	Name	Type	Description
1	ACS1	I	Audio Clock Select 1. Selects ACLK on pin 6. See table above.
2	X2	O	Crystal connection. Connect to 27 MHz crystal. Leave unconnected for clock input.
3	X1/ICLK	I	Crystal connection. Connect to 27 MHz crystal or connect to 27 MHz input clock.
4	VDD	P	Connect to +5V.
5	GND	P	Connect to ground.
6	ACLK	O	Audio Clock output. Determined by status of ACS1, ACS0. See table above.
7	NCLK	O	NTSC/PAL Clock output Determined by status of ACS1 and ACS0. See table above.
8	27M	O	27.00 MHz buffered reference clock output. Duty cycle matches input clock.
9	PCS	I	Processor Clock Select. Selects processor clocks on pins 10 and 14. See table above.
10	PCLK/2	O	Processor Clock output divided by two. Determined by status of PCS. See table above.
11	GND	P	Connect to ground.
12	NCS1	I	NClock Select 1. Selects NTSC/PAL clock on pin 7. See table above.
13	VDD	P	Connect to +5V.
14	PCLK	O	Processor Clock output Determined by status of PCS. See table above.
15	NCS0	I	NClock Select 0. Selects NTSC/PAL clock on pin 7. See table above.
16	ACS0	I	Audio Clock Select 0. Selects audio clock on pin 6. See table above.

Key: I = Input, O = output, P = power supply connection



Electrical Specifications

Parameter	Conditions	Minimum	Typical	Maximum	Units
ABSOLUTE MAXIMUM RATINGS (note 1)					
Supply voltage, VDD	Referenced to GND			7	V
Inputs and Clock Outputs	Referenced to GND	-0.5		VDD+0.5	V
Ambient Operating Temperature		0		70	°C
Soldering Temperature	Max of 20 seconds			260	°C
Storage temperature		-65		150	°C
DC CHARACTERISTICS (VDD = 5.0V unless noted)					
Operating Voltage, VDD		4.5		5.5	V
Input High Voltage, VIH, X1/ICLK pin only		3.5	2.5		V
Input Low Voltage, VIL, X1/ICLK pin only			2.5	1.5	V
Input High Voltage, VIH		2			V
Input Low Voltage, VIL				0.8	V
Output High Voltage, VOH	IOH=-25mA	2.4			V
Output Low Voltage, VOL	IOL=25mA			0.4	V
Output High Voltage, VOH, CMOS level	IOH=-8mA	VDD-0.4			V
Operating Supply Current, IDD	No Load, note 2		45		mA
Short Circuit Current	Each output		±100		mA
Input Capacitance			7		pF
Frequency error, ACLK				0	ppm
Frequency error, 24.576 MHz clock				40	ppm
AC CHARACTERISTICS (VDD = 5.0V unless noted)					
Input Frequency			27.000		MHz
Output Clock Rise Time	0.8 to 2.0V			1.5	ns
Output Clock Fall Time	2.0 to 0.8V			1.5	ns
Output Clock Duty Cycle	At 1.4V	40		60	%
Absolute Jitter, short term			200		ps
Skew of PCLK and PCLK/2	Rising edges at 1.4V	-500	0	500	ps

Notes: 1. Stresses beyond those listed under Absolute Maximum Ratings could cause permanent damage to the device. Prolonged exposure to levels above the operating limits but below the Absolute Maximums may affect device reliability.

2. With NUCLK at 40MHz, PCLK at 66.0MHz, and ACLK at 16.93MHz.

External Components

The MK2751-01 requires a minimum number of external components for proper operation. Decoupling capacitors of 0.1µF should be connected between VDD and GND (pins 4 and 5, and 13 and 11), as close to the MK2751 as possible. A series termination resistor of 33 Ω may be used for each clock output. If a clock input is not used, the 27.00 MHz crystal must be fundamental mode, parallel resonant, and connected as close to the chip as possible. Crystal capacitors should be connected from pins X1 to ground and X2 to ground. The value (in pF) of these crystal capacitors should be $= (C_L - 4) * 2$, where C_L is the crystal load capacitance in pF. So for a crystal with 16pF load capacitance, the crystal capacitors should be 24pF each.



Package Outline and Package Dimensions

16 pin SOIC narrow

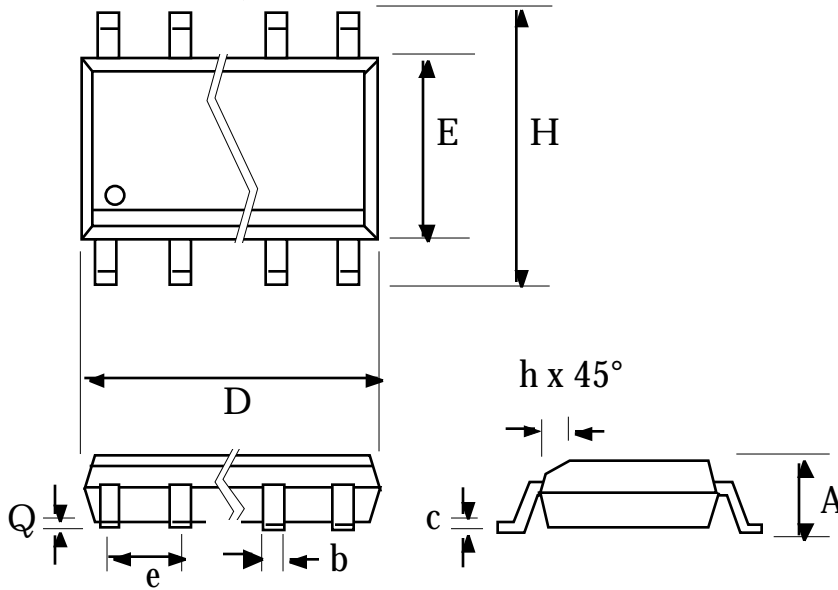

Symbol	Inches		Millimeters	
	Min	Max	Min	Max
A	0.055	0.070	1.397	1.778
b	0.013	0.019	0.330	0.483
c	0.007	0.010	0.190	0.254
D	0.385	0.400	9.779	10.160
E	0.150	0.160	3.810	4.064
H	0.225	0.245	5.715	6.223
e	.050 BSC		1.27 BSC	
h		0.016		0.406
Q	0.004	0.01	0.102	0.254

Ordering Information

Part/Order Number	Marking	Shipping packaging	Package	Temperature
MK2751-01S	MK2751-01S	tubes	16 pin SOIC	0-70°C
MK2751-01STR	MK2751-01S	tape and reel	16 pin SOIC	0-70°C

While the information presented herein has been checked for both accuracy and reliability, MicroClock Incorporated assumes no responsibility for either its use or for the infringement of any patents or other rights of third parties, which would result from its use. No other circuits, patents, or licenses are implied. This product is intended for use in normal commercial applications. Any other applications such as those requiring extended temperature range, high reliability, or other extraordinary environmental requirements are not recommended without additional processing by MicroClock. MicroClock reserves the right to change any circuitry or specifications without notice. MicroClock does not authorize or warrant any MicroClock product for use in life support devices or critical medical instruments.