

MMD-1030HSM

GaAs MMIC Doubler

DEVICE OVERVIEW

General Description

The MMD-1030HSM is a passive double balanced MMIC doubler covering 10 to 30 GHz on the output. It features excellent conversion loss, superior isolations and harmonic suppressions across a broad bandwidth, in a small form factor. The MMD-1030HSM is available in a lead-free, RoHS compliant QFN surface mount package and is compatible with standard leaded and lead-free PCB reflow soldering processes. The MMD-1030HSM is a superior alternative to Marki Microwave carrier and packaged doublers.

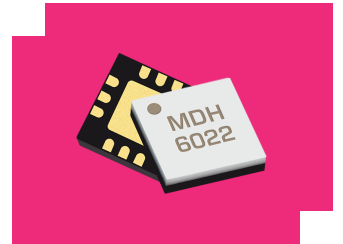

Features

- Compact 3mm QFN SMT Style Package
- Broadband Performance
- Excellent Unit-to-Unit Repeatability
- RoHS Compliant

Applications

N/A

Functional Block Diagram

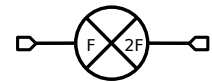

Part Ordering Options

Part Number	Description	Package	Packing Size	Green Status	Product Lifecycle	Export Classification
EVAL-MMD-1030H	Evaluation Board, GaAs MMIC 10 -30 GHz Doubler	-	-	RoHS REACH REACH	Released	EAR99
MMD-1030HSM	GaAs MMIC Doubler	QFN	-	RoHS REACH REACH	Released	EAR99
MMD-1030H-TR	Tape and Reel, GaAs MMIC Doubler	QFN	7"	RoHS REACH REACH	Released	EAR99

Table Of Contents

■ Device Overview

- General Description
- Features
- Applications
- Functional Block Diagram

■ Port Configuration and Functions

- Port Functions

■ Specifications

- Absolute Maximum Ratings
- Package Information
- Electrical Specifications
- Typical Performance Plots

■ Mechanical Data

- Outline Drawing

■ Footprint Image

■ Evaluation Board



- Evaluation Board Bill of Materials
- Evaluation Board Outline Drawing

■ Operation

- Application Circuit

Port Configuration and Functions

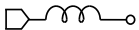
Port Functions

Port	Function	Description	Equivalent Circuit for Package
Pin 2	F input	Input 1x Frequency Port. The input port is DC open and AC matched to 50 Ohms from 5 to 15 GHz. Blocking capacitor is optional.	
Pin 8	2F Output	2x Input Frequency output port. The output port is DC open and AC matched to 50 Ohms from 10 to 30 GHz. Blocking capacitor is optional.	

Specifications

Absolute Maximum Ratings

Parameter	Maximum Rating	Unit
Maximum Operating Temperature	100	°C
Maximum Storage Temperature	125	°C
Minimum Operating Temperature	-55	°C
Minimum Storage Temperature	-65	°C
RF Power Handling, 100°C	20	dBm
RF Power Handling, 25°C	25	dBm

Package Information

Parameter	Details	Rating
Dimensions	-	3x3 mm

Electrical Specifications

Specifications guaranteed from -55 to +100°C, measured in a 50Ω system. All bare die are 100% DC tested and 100% visual inspected. RF testing is performed on a sample basis to verify conformance to datasheet guaranteed specifications.

Parameter	Test Conditions	Minimum Frequency (GHz)	Maximum Frequency (GHz)	Min	Typ	Max	Unit
1F Input Drive Level, H Diode Option	Input=5-15GHz Output=10-30GHz	5	15	10	14	17	dBm
Conversion Loss	Second Harmonic Output	10	30	-	12	-	dB
Isolation, 1F ¹	Input=5-15GHz Output=10-30GHz	5	15	-	46	-	dB
Isolation, 3F ²	Input=5-15GHz Output=10-30GHz	10	30	-	57	-	dB
Isolation, 4F ³	Input=5-15GHz Output=10-30GHz	10	30	-	31	-	dB
Suppression, 1F ⁴	Input=5-15GHz Output=10-30GHz	5	15	-	34	-	dB
Suppression, 3F ⁵	Input=5-15GHz Output=10-30GHz	10	30	-	46	-	dB
Suppression, 4F ⁶	Input=5-15GHz Output=10-30GHz	10	30	-	19	-	dB
Input Frequency Range	-	-	-	5	-	15	GHz
Output Frequency Range	-	-	-	10	-	30	GHz

[1][2][3] Isolation is defined as relative to the fundamental input power.

[4][5][6] Suppression is relative to doubled output power.

Typical Performance Plots

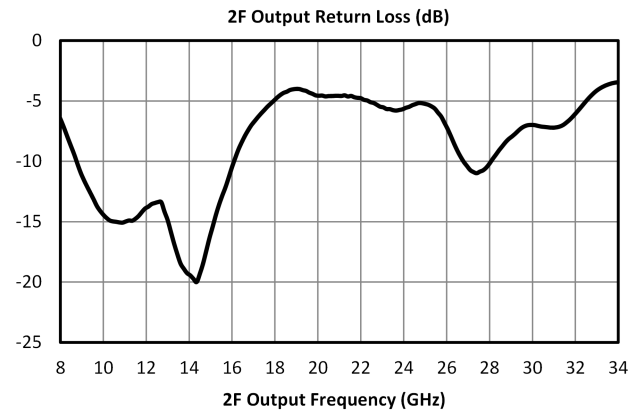
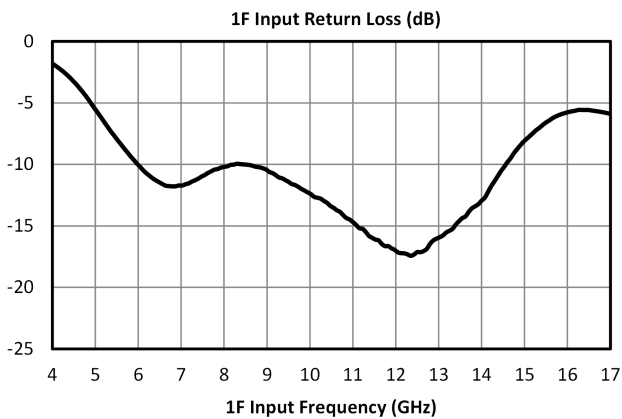
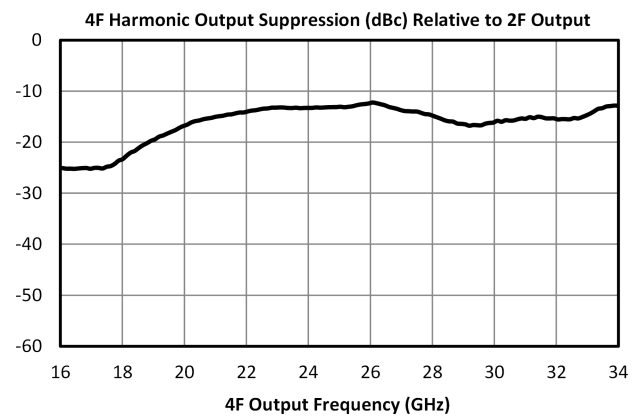
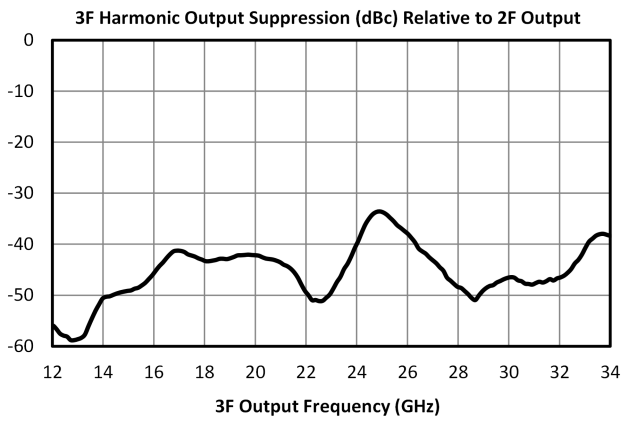
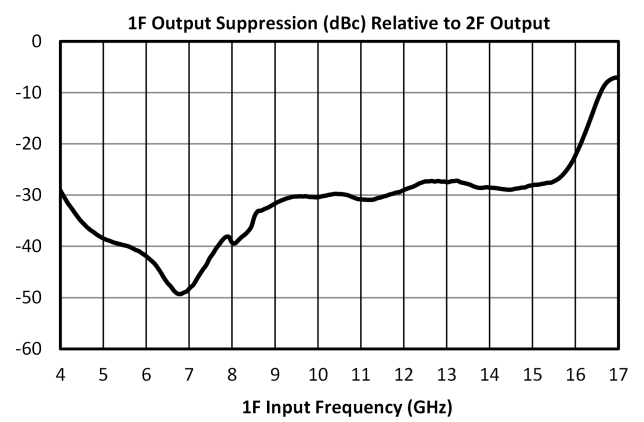
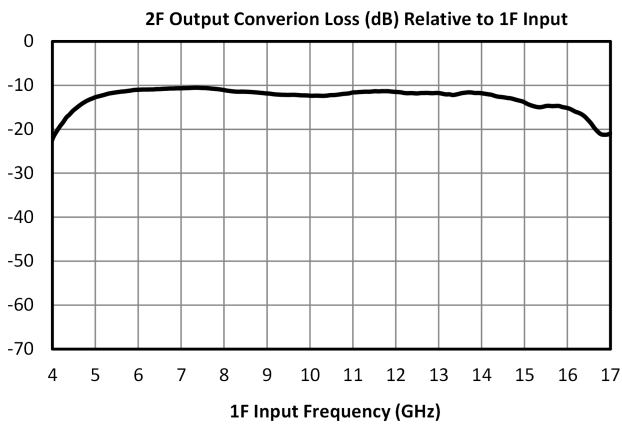
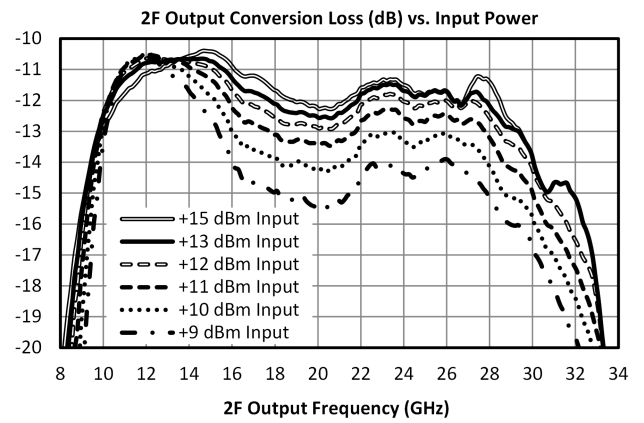
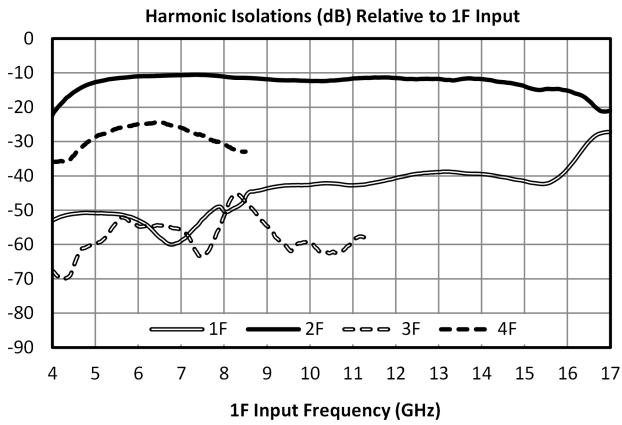

Application Circuit

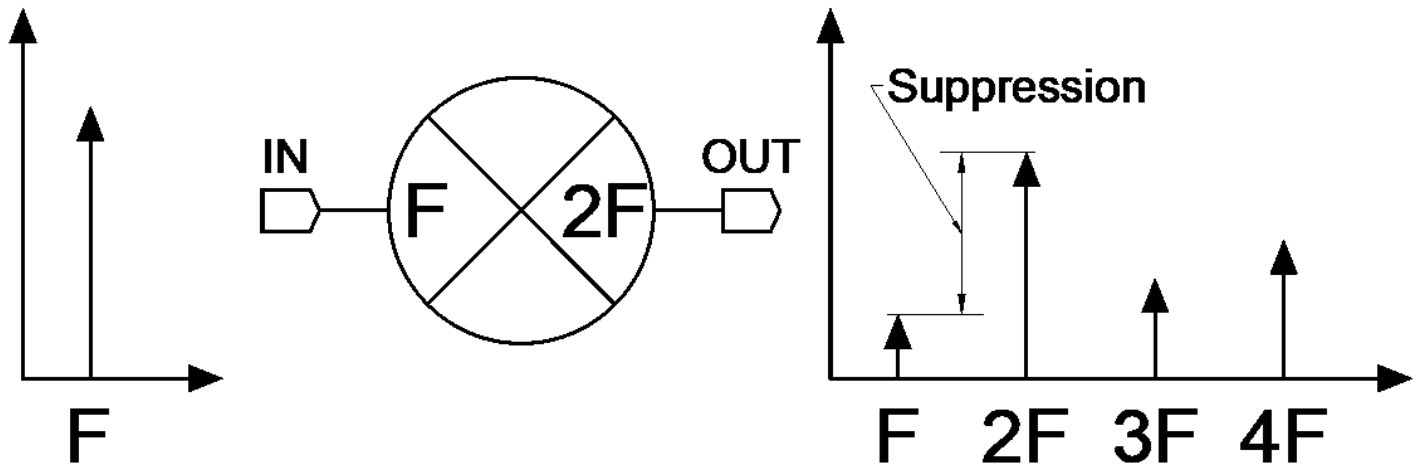

Mechanical Data

Outline Drawing

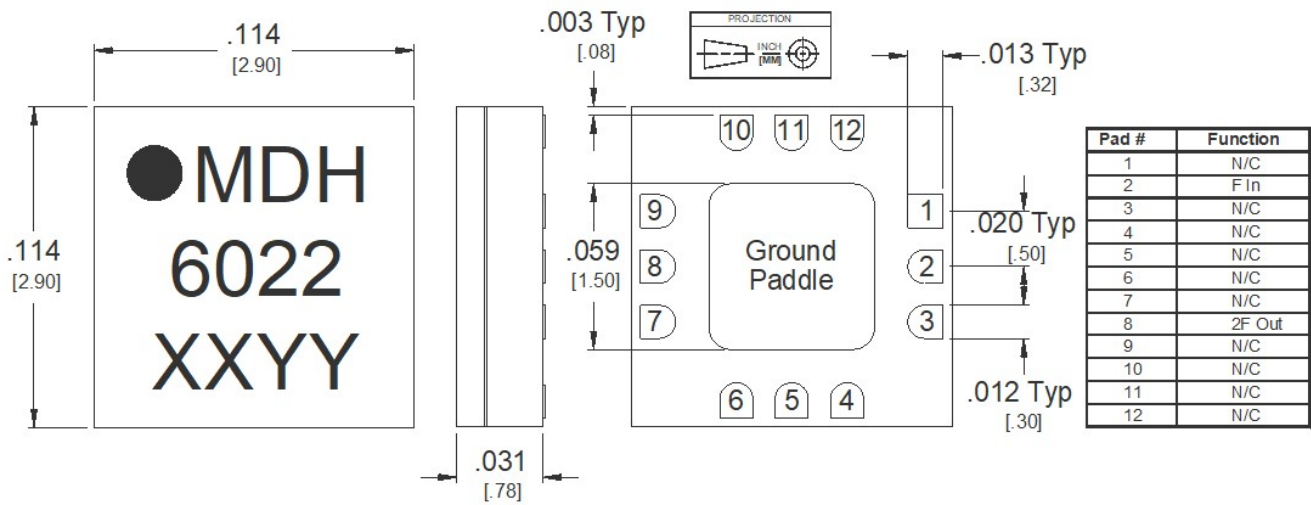

Outline Drawing – 3mm QFN package

Substrate material is Ceramic.

I/O Leads and Ground Paddle are 1.4±0.6 microns (55±24 micro-inches) Au over 1.3 microns (51 micro-inches) Ni.

All unconnected pads should be connected to PCB RF ground.

Footprint Image

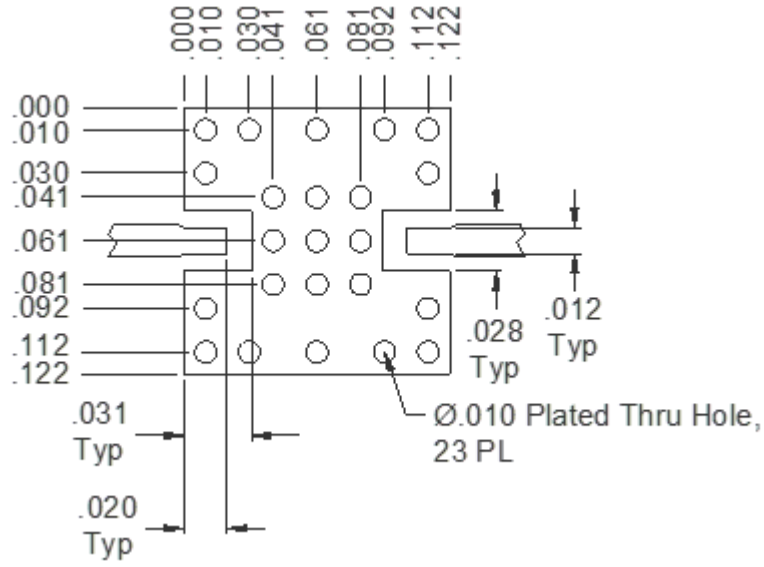

Evaluation Board

Evaluation Board Bill of Materials



Port	Connector Type
F	SMA Female
2F	2.92 mm Female

Note: Eval Connectors are not removeable.

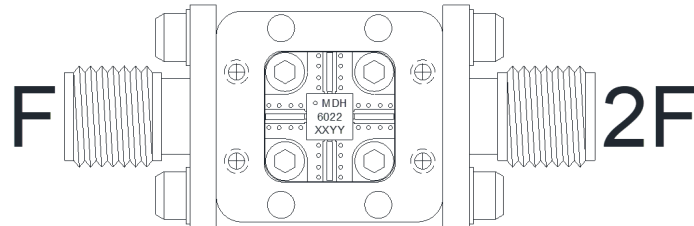
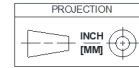

Backside Label

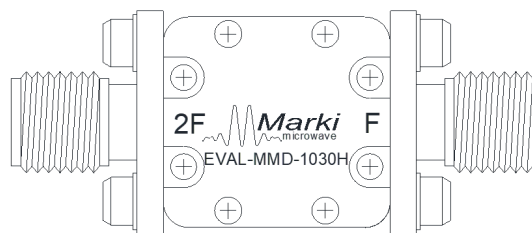

DISCLAIMER

MARKI MICROWAVE, INC., ("MARKI") PROVIDES TECHNICAL SPECIFICATIONS AND DATA (INCLUDING DATASHEETS), APPLICATION OR OTHER DESIGN ADVICE, WEB TOOLS, AND OTHER INFORMATION AND RESOURCES "AS IS" AND WITH ALL FAULTS. MARKI DISCLAIMS ALL WARRANTIES, EXPRESS OR IMPLIED, INCLUDING, WITHOUT LIMITATION, ANY IMPLIED WARRANTIES OF MERCHANTABILITY, FITNESS FOR A PARTICULAR PURPOSE, OR NON-INFRINGEMENT.

These resources are intended for developers skilled in the art designing with Marki products. You are solely responsible for (1) selecting the appropriate products for your application, (2) designing, validating, and testing your application, and (3) ensuring your application meets applicable standards and other requirements. Marki makes no guarantee regarding the suitability of its products for any particular purpose, nor does Marki assume any liability whatsoever arising out of your use or application of any Marki product. Marki grants you permission to use these resources only for development of an application that uses Marki products. Other reproduction or use of these resources is strictly prohibited. No license is granted to any other Marki intellectual property or to any third-party intellectual property. Marki reserves the right to make changes to the product(s) or information contained herein without notice.

MARKI MICROWAVE and T3 MIXER are trademarks or registered trademarks of Marki Microwave, Inc. All other trademarks used are the property of their respective owners.

© 2022 - 2023, Marki Microwave, Inc