

Low-Current Superhet Remote Control Receiver

Description

The U4311B-FS is a monolithic integrated circuit in bipolar technology for low-current UHF remote control super-heterodyne receivers in amplitude- or frequency-modulated mode. Typical applications are keyless car

lock-, alarm- or tele-control remote indication systems. Especially for automotive applications, it supports a superhet design with about 1 mA total current consumption as required by the car manufacturers.

Features

- Usable for amplitude- and frequency-modulated transmission systems
- Extremely low quiescent current (approximately 1 mA in standby mode due to wake-up concept)
- Wide power supply voltage range 3 to 13 V
- Sensitive IF amplifier for 10.7-MHz operating frequency
- Logarithmic AM demodulator
- FM demodulator
- Monoflop output to wake up a microcontroller
- High-performance operational amplifier to realize a data recovering filter
- Non-inverting clamping comparator with amplitude-dependent hysteresis for data regeneration

Block Diagram

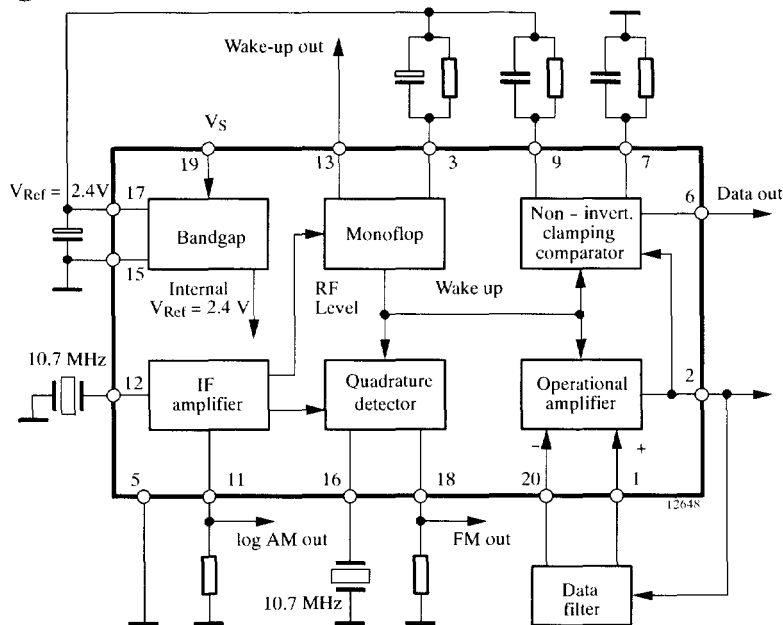

Figure 1. Block diagram

Ordering Information

Extended Type Number	Package	Remarks
U4311B-MFSG3	SSO20	Ambient temperature up to +105°C

Pin Description

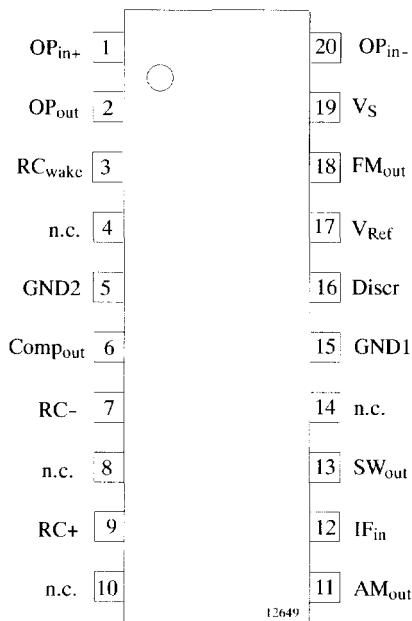

Figure 2. Pinning

Pin	Symbol	Function
1	OP _{in+}	OP amplifier non-inverted input
2	OP _{out}	OP amplifier output
3	RC _{wake}	RC wake-up reset time
4	n.c.	Not connected
5	GND2	Ground of the logical circuits
6	Comp _{out}	Comparator output
7	RC-	Comparator time constant
8	n.c.	Not connected
9	RC+	Comparator time constant
10	n.c.	Not connected
11	AM _{out}	AM current output
12	IF _{in}	IF input
13	SW _{out}	Wake-up output
14	n.c.	Not connected
15	GND1	Ground of the analog circuits
16	Discr	FM discriminator tank
17	V _{Ref}	Reference voltage
18	FM _{out}	FM discriminator output
19	V _S	Supply voltage
20	OP _{in-}	OP amplifier inverted input

Internal connections see figures 4 to 19

Absolute Maximum Ratings

Parameters	Symbol	Value	Unit
Supply voltage	V _S	13	V
Power dissipation T _{amb} = 85°C	P _{tot}	400	mW
Junction temperature	T _j	125	°C
Storage temperature	T _{stg}	-55 to +125	°C
Ambient temperature for SSO20	T _{amb}	-40 to +105	°C

Thermal Resistance

Parameters	Symbol	Value	Unit
Junction ambient SSO20	R _{thJA}	140	K/W

Electrical Characteristics

$V_S = 5\text{ V}$, $T_{\text{amb}} = 25^\circ\text{C}$, $f_{\text{in}} = 10.7\text{ MHz}$; FM part: $f_{\text{mod}} = 1\text{ kHz}$, $f_{\text{dev}} = 22.5\text{ kHz}$; AM part: $f_{\text{mod}} = 1\text{ kHz}$, $m = 100\%$ unless otherwise specified

Parameters	Test Conditions / Pins	Symbol	Min.	Typ.	Max.	Unit
Characteristics						
Supply-voltage range	Pin 19	V_S	3		12	V
Quiescent supply current	Pin 19	I_q		1	1.3	mA
Active supply current	Pin 19	I_{act}		2.8	3.6	mA
Bandgap						
Regulated voltage	Pin 17	V_{Ref}	2.3	2.4	2.5	V
Output current	Pin 17	I_{Ref}			5	mA
Source resistance	Pin 17	R_{Ref}		2.3	5	Ω
External capacitor	Pin 17	C_{Ref}	10			μF
Power-supply rejection ratio	$f = 50\text{ Hz}$ Pin 17	psrr		60		dB
IF amplifier						
Input resistance	Pin 12	R_{in}	180	330	520	Ω
Input capacitance	Pin 12	C_{in}		5		pF
Typical internal 3 dB frequency	IF level 70 dB μV Pins 12 and 18	$f_{3\text{dB}}$	8		12	MHz
-3 dB limiting point	Pin 12	$V_{\text{FM}3\text{dB}}$		30		dB μV
Recovered data voltage	Pin 18	V_{FMout}	50	130	230	mV
FM detector output resistance	Pin 18	R_{FMout}		50		k Ω
AM rejection ratio	$m = 30\%$ Pins 12 and 18	AM_{rr}		25		dB
Maximum AM input voltage	Pin 12	V_{AMmax}		90		dB μV
AM quiescent current	Pin 11	I_{AMout}	10	22	37	μA
Maximum AM current	Pin 11	I_{AMoutmax}		100		μA
Operational amplifier						
Gain-bandwidth product	Pins 1, 2 and 20	f_t	3	4	6.5	MHz
Excess phase	Pins 1, 2 and 20	δ		80		degree
Open loop gain	Pins 1, 2 and 20	g_0	50	70	95	dB
Output voltage range	Pin 2	ΔV_{out}		1.55		V
Common mode input voltage	Pins 1 and 20	V_{in}	0.7		1.7	V
Input offset voltage	Pins 1 and 20	V_{os}	-2.5	0	+2.5	mV
Maximum output current	Pin 2	I_{out}			5	mA
Common-mode rejection ratio	Pin 1 and 20	cmrr	65	85		dB
Total harmonic distortion	$V_{\text{in}} < 300\text{ mV}$, $f = 33\text{ kHz}$, unity gain circuit Pin 2	thd		1	3	%

Electrical Characteristics (continued)

$V_S = 5\text{ V}$, $T_{\text{amb}} = 25^\circ\text{C}$, $f_{\text{in}} = 10.7\text{ MHz}$; FM part: $f_{\text{mod}} = 1\text{ kHz}$, $f_{\text{dev}} = 22.5\text{ kHz}$; AM part: $f_{\text{mod}} = 1\text{ kHz}$, $m = 100\%$ unless otherwise specified

Parameters	Test Conditions / Pins	Symbol	Min.	Typ.	Max.	Unit
Power-supply rejection ratio	$f = 50\text{ Hz}$ Pin 2	psrr	65	85		dB
Clamping comparator						
Typical common-mode input voltage range	Pin 2	V_{cmvr}	0.8		1.6	V
Maximum distortion voltage	$V_{\text{signal}} = 100\text{ mV}$, $R_+ = R_- = 50\text{ k}\Omega$, $C_+ = C_- = 200\text{ nF}$, $f_{\text{disto}} = 50\text{ Hz}$, $f_{\text{signal}} = 1\text{ kHz}$ Pin 2	V_{dmax}			200	mV
Output voltage	$V_2 > (V_7 + V_9) / 2$ (10-k Ω load to V_{Ref}) Pin 6	V_{cout}		V_{Ref}		V
Output voltage	$V_2 < (V_7 + V_9) / 2$ (10-k Ω load to V_{Ref}) Pin 6	V_{cout}	0	150	250	mV
Wake-up circuit						
Minimum wake-up level	Pin 12	V_{in}		40		dB μV ¹⁾
Internal charging resistor	Pin 3	R_{int}		1.5		k Ω
Threshold voltage	Pin 3	V_{th}		1.6		V
Output switch current	Pin 13	I_{SW}	180	250	550	μA
Output switch voltage	Pin 13	V_{SW}			5.5	V ²⁾
External wake-up resistor	Pins 3 and 17	R_{WU}	22			k Ω
External wake-up capacitor	Pins 3 and 17	C_{WU}			10	μF
Hold time ($\pm 30\%$)		t_{h}		$\approx 1.5 \times R_{\text{WU}} \times C_{\text{WU}}$		s ³⁾
Delay time ($\pm 30\%$)		t_{d}		$\approx C_{\text{WU}} \times 0.75\text{ k}\Omega$		s ³⁾

- 1) Measured at Pin 9, (12) referred to 330 Ω
- 2) Protected by a Z-diode, see figure 13
- 3) Valid for $0.1\ \mu\text{F} \leq C_{\text{WU}} \leq 10\ \mu\text{F}$ and $22\text{ k}\Omega \leq R_{\text{WU}} \leq 680\text{ k}\Omega$

Internal Pin Circuitry

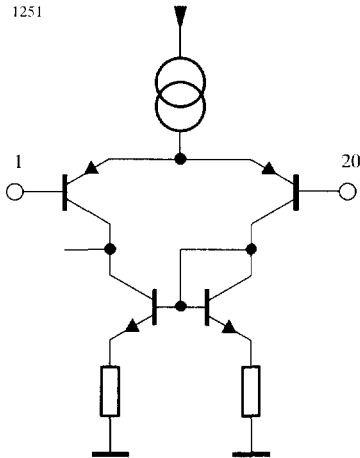

Figure 4. Pin 1 OP_{in+}

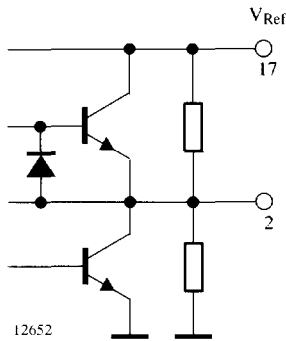

Figure 5. Pin 2 OP_{out}

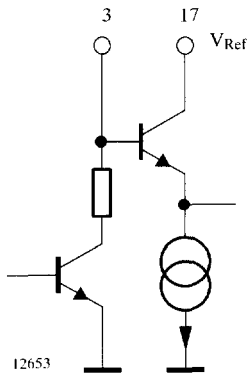

Figure 6. Pin 3 RC_{wake}



Figure 7. Pin 5 GND2

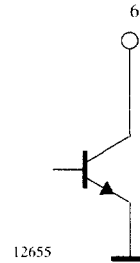

Figure 8. Pin 6 Comp_{out}

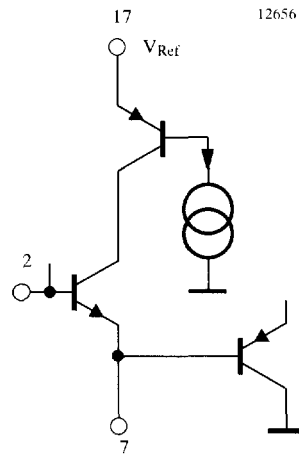

Figure 9. Pin 7 RC₋

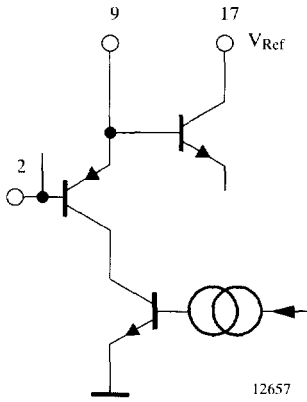

Figure 10. Pin 9 RC+

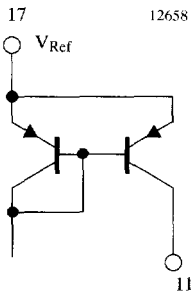

Figure 11. Pin 11 AM_{out}

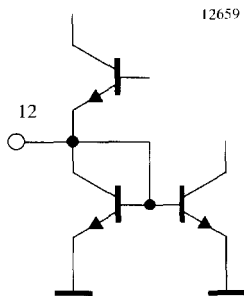

Figure 12. Pin 12 IF_{in}

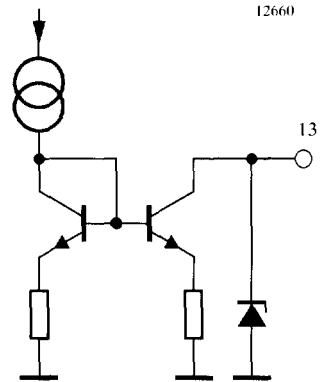

Figure 13. Pin 13 SW_{out}

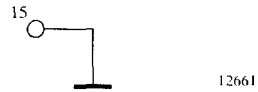

Figure 14. Pin 15 GND1

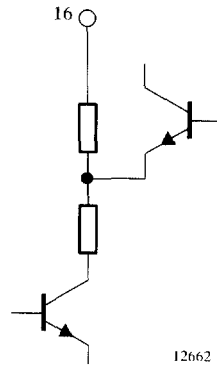

Figure 15. Pin 16 Discr

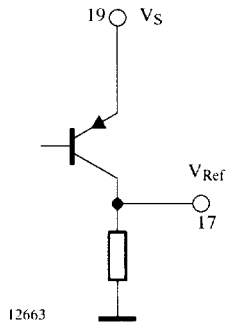

Figure 16. Pin 17 V_{Ref}

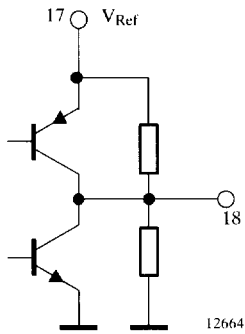

Figure 17. Pin 18 FM_{out}

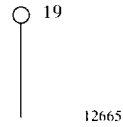

Figure 18. Pin 19 V_S

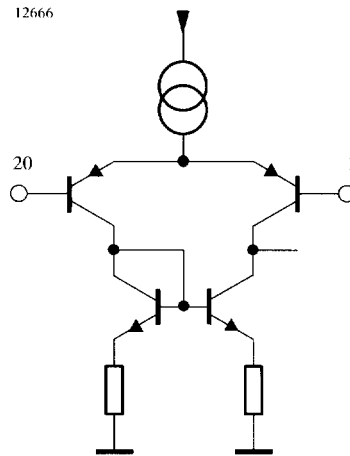

Figure 19. Pin 20 OP_{in-}

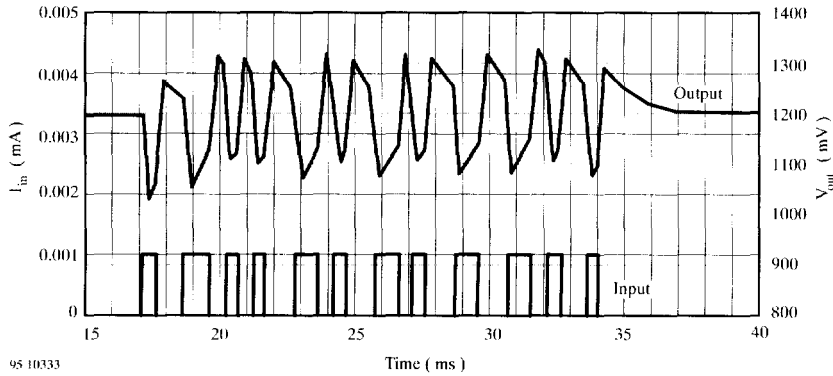

Figure 20. Time domain response of 2-kHz Bessel lowpass data filter

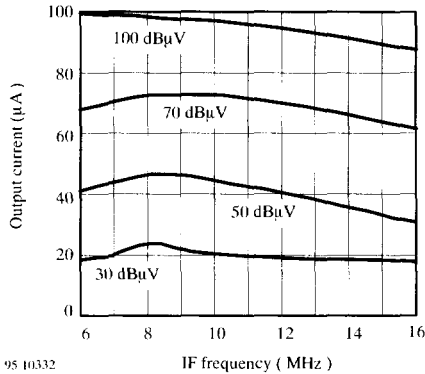

Figure 21. IF-frequency response

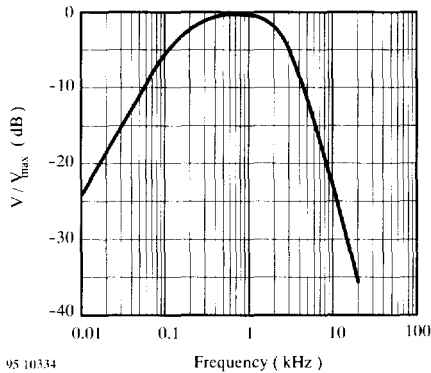

Figure 22. Frequency response of 2-kHz Bessel lowpass data filter

Data-Recovering Filter

The test circuit in figures 23 and 26 includes an example of a data-recovering filter realized with the components R_1 , R_2 , C_1 , C_2 , C_3 . It is of a second-order Bessel type with lowpass characteristic, a 3-dB cut-off frequency of 2 kHz and an additional highpass characteristic for suppressing dc and low-frequency ac components. Simulation of time domain and frequency response can be seen in figures 20 and 22. This filter gives a typical application of a 1-kBaud Manchester-code amplitude-modulated transmission.

The capacitor C_2 is responsible for the highpass cut-off frequency. In order to a correct pulse response, this highpass cut-off frequency should be as low as possible. Figure 20 shows the transient response and the influence of the dc component. The first pulses might be wrong if the highpass cut-off frequency is too low. For this reason, some burst bits must be transmitted before the real data transmission starts. On the other hand, if the cut-off frequency is too high, roof shaping of the rectangle pulses at the operational amplifier output might cause problems.

The lowpass cut-off frequency and the maximum transimpedance V_{out}/I_{in} are distinguished by the further external elements. Careful design of the data filter enables optimized transmission range. For designing other filter parameters, please refer to filter design handbooks/ programs or request Atmel Wireless & Microcontrollers for support.

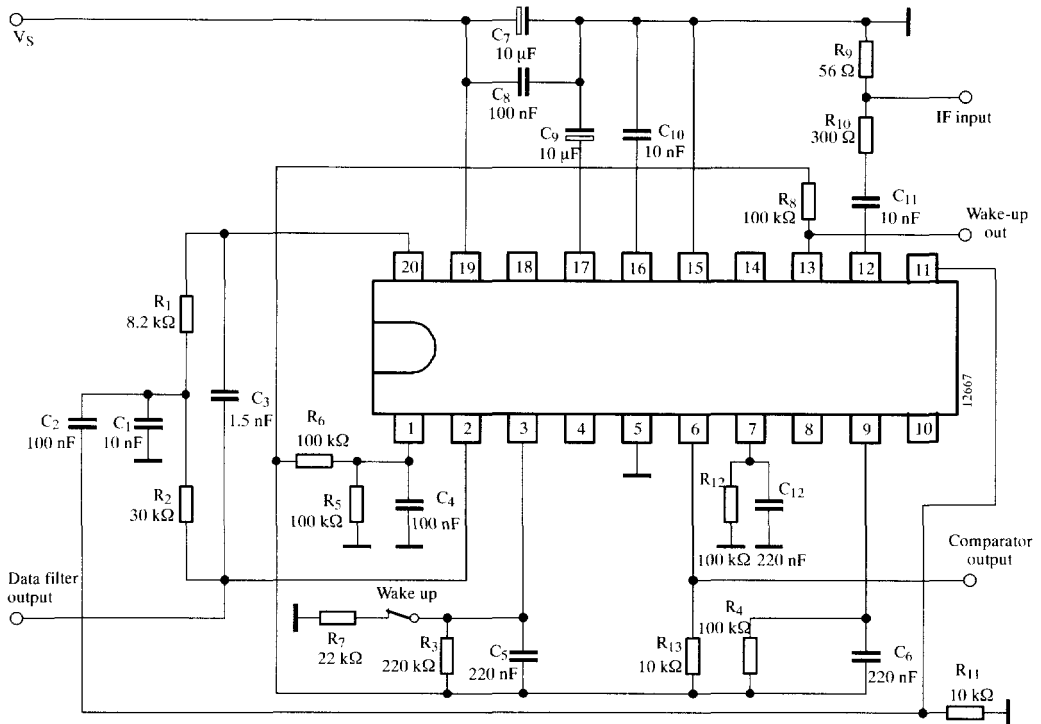
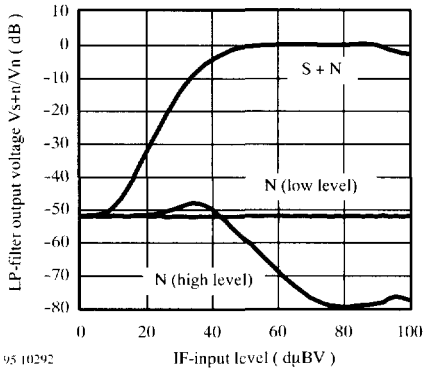
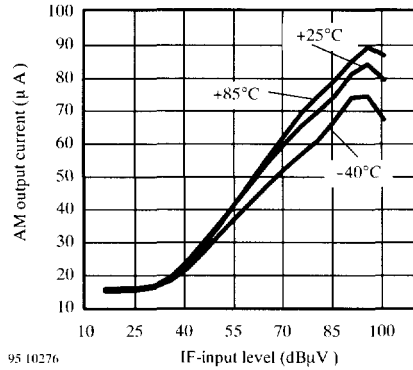

Figure 23. AM test circuit with 2-kHz Bessel lowpass data filter



95 10292

Figure 24. Signal-to-noise ratio AM



95 10276

Figure 25. AM-demodulator characteristic vs. temperature

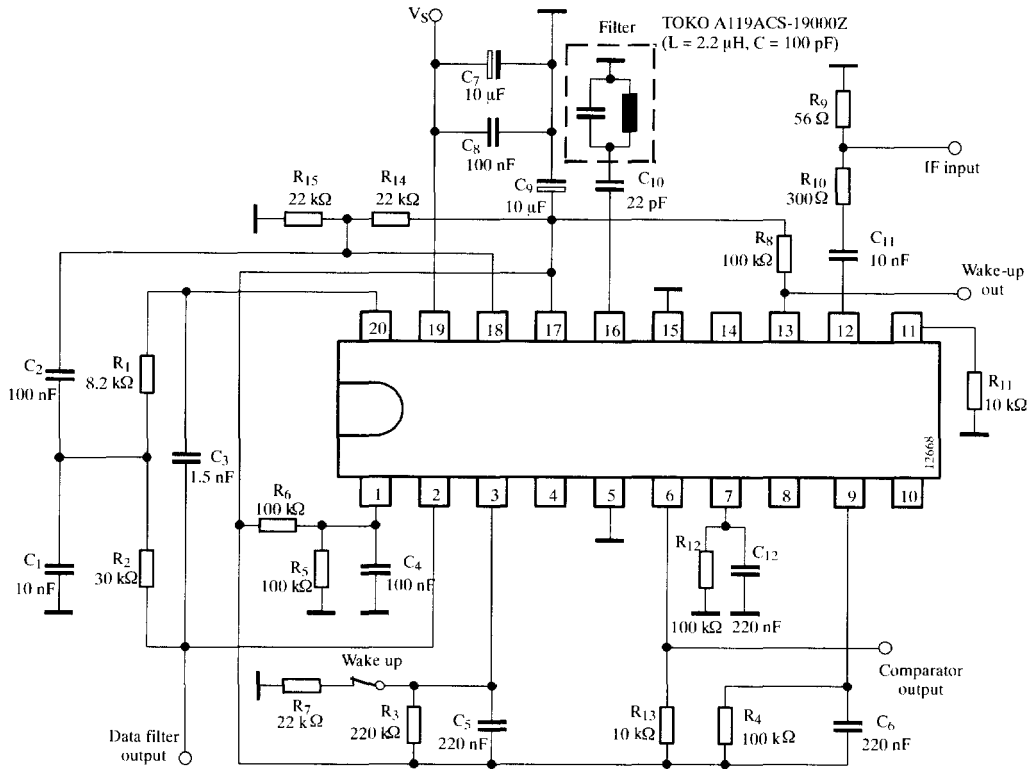

Figure 26. FM test circuit with 2-kHz Bessel lowpass data filter

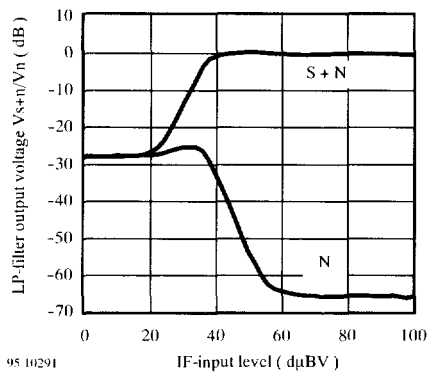

Figure 27. Signal-to-noise ratio FM; deviation 22.5 kHz

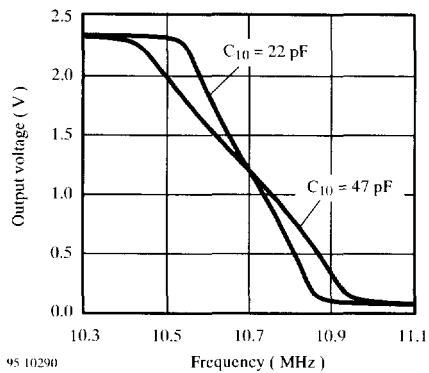

Figure 28. FM-discriminator characteristic

Application

The U4311B-FS is well-suited to implement UHF remote control or data transmission systems, based on a low-current superheterodyne receiver concept. SAW-devices may be used in the transmitter's as well as in the receiver local oscillator. The front end should be a discrete circuit application with low-current UHF transistors such as S822T or S852T (Vishay Telefunken). The frequency of the local oscillator can be determined either by coaxial resonators or SAW devices. Due to the large

SAW-resonator, tolerance an IF bandwidth – and in a FM system additionally the discriminator amplitude characteristic (see figure 28) – of 300 kHz or higher is proposed. As the circuit needs only 3.0 V supply voltage for operation, the front end may be a stacked design in order to achieve a total receiver current consumption of approximately 1 mA. Figure 29 shows a principle receiver concept diagram.

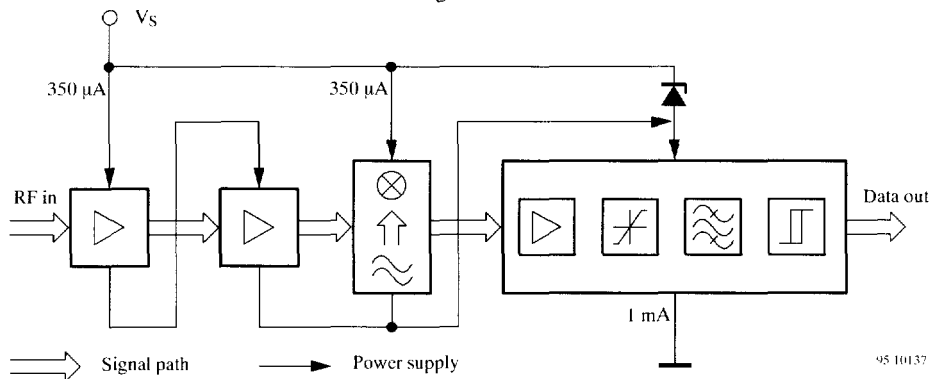

Figure 29. Principle diagram of a UHF remote control receiver

Package Information

Package SSO20

Dimensions in mm

