

SGT21B13, SGT21B13A, SGT22B13, SGT22B13A, SGT23B13, SGT23B13A, SGT27B13, SGT27B13A, SGT27B13B

Bidirectional Transient Surge Suppressors (Surgecor)

January 1998

Features

- Clamping Voltage..... 210V, 220V,
230V and 270V
- Peak Transient Surge Current..... 300A
- Minimum Holding Current..... 130mA
- Continuous Protection
- Low On-State Voltage
- UL Recognized File #E135010 to STD 497B

Applications

- Data and Communication Links
- Computer Modems
- Alarm Systems

Description

These surgecor devices are designed to protect telecommunication equipment, data links, alarm systems, power supplies and other sensitive electrical circuits from damage by switching transients, lightning strikes, load changes, commutation spikes and line crosses.

Bidirectional surgecor devices are constructed using two monolithic compound chips each consisting of a thyristor whose gate region contains a special diffused section which acts as a zener diode. This chips are connected in anti parallel, providing bidirectional protection. This zener diode section permits anode voltage turn on of the structure.

Initial clamping by the zener diode section, and fast turn on by the thyristor, provide excellent voltage limiting even on very fast rise time transients. The thyristor also features very high holding current, which allows the surgecor to recover to its high impedance off state after a transient.

All these devices are supplied in a 2 lead, modified TO-202 VERSATAB package.

Equivalent Schematic Symbols

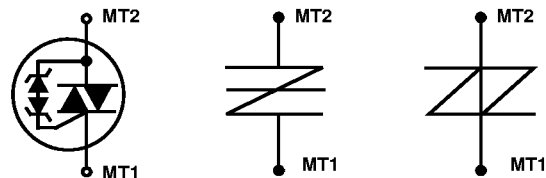

Packaging

MODIFIED TO-202

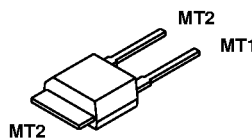

SGT2XB13, SGT2XB13A, SGT27B13B

Absolute Maximum Ratings $T_C = 25^\circ\text{C}$

	SGT21B13 SGT21B13A	SGT22B13 SGT22B13A	SGT23B13 SGT23B13A	SGT27B13 SGT27B13A SGT27B13B	UNITS
Continuous Off State Voltage:					
V_{DM}	185	190	200	235	V
V_{RM}	185	190	200	235	V
Transient Peak Surge Current I_{TSM}					
1 μs x 2 μs (Note 1)	300	300	300	300	A
8 μs x 20 μs	200	200	200	200	A
10 μs x 560 μs	125	125	125	125	A
10 μs x 1000 μs	100	100	100	100	A
One Half Cycle 50Hz to 60Hz (Note 2)	60	60	60	60	A
One Second 50Hz to 60Hz, Halfwave	30	30	30	30	A
Operating Temperature (T_A)	-40 to 85		-40 to 85		$^\circ\text{C}$
Storage Temperature Range (T_{STG})	-40 to 150		-40 to 150		$^\circ\text{C}$

NOTES:

- Unit designed not to fail open below: 450A.
- One every 30s maximum.

CAUTION: Stresses above those listed in "Absolute Maximum Ratings" may cause permanent damage to the device. This is a stress only rating and operation of the device at these or any other conditions above those indicated in the operational sections of this specification is not implied.

Electrical Specifications At Case Temperature, $T_C = 25^\circ\text{C}$, Unless Otherwise Specified

PARAMETER	SYMBOL	TEST CONDITIONS	MIN	TYP	MAX	UNITS
Off-State Current	I_{DM}, I_{RM}	Maximum Rated V_{DM}, V_{RM} $T_A = 25^\circ\text{C}$ $T_A = 85^\circ\text{C}$	- -	- -	200 100	nA μA
Clamping Voltage SGT21B13 SGT21B13A SGT22B13 SGT22B13A SGT23B13 SGT23B13A SGT27B13 SGT27B13A SGT27B13B	V_Z	$I_Z < 200\mu\text{A}$	210 210 220 220 230 230 270 270 270	- - - - - - - - -	250 270 260 270 270 295 325 340 355	V V V V V V V V V
Breakover Voltage SGT21B13 SGT21B13A SGT22B13 SGT22B13A SGT23B13 SGT23B13A SGT27B13 SGT27B13A SGT27B13B	V_{BO}	$dv/dt = 100\text{V}/\mu\text{s}$	- - - - - - - - -	- - - - - - - - -	270 290 280 290 290 315 345 360 375	V V V V V V V V V
Holding Current	I_H		130	-	-	mA
On-State Voltage	V_T	$I_T = 10\text{A}$	-	-	2	V
Main Terminal Capacitance	C_O	$V_{DM} = V_{RM} = 50\text{V}$, Frequency = 1MHz	-	50	-	pF

Performance Curves

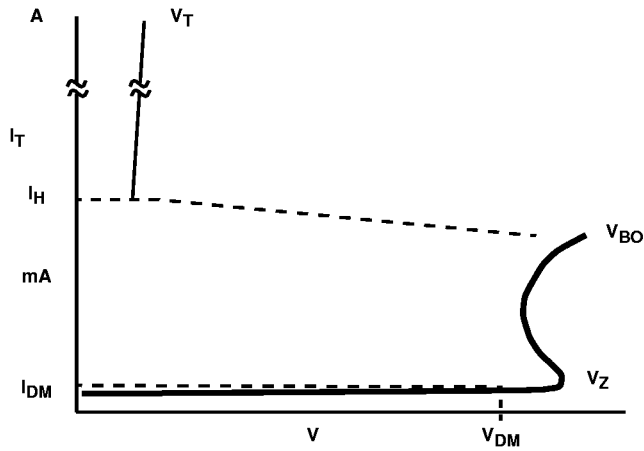

FIGURE 1. TYPICAL VOLT-AMPERE CHARACTERISTICS FOR ALL TYPES

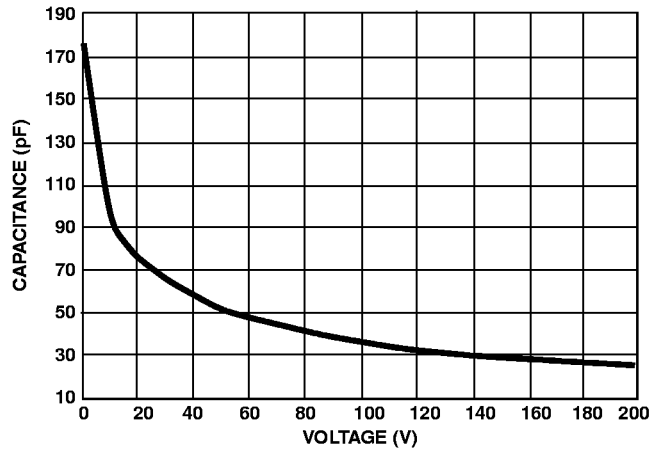

FIGURE 2. TYPICAL CAPACITANCE vs VOLTAGE FOR ALL TYPES

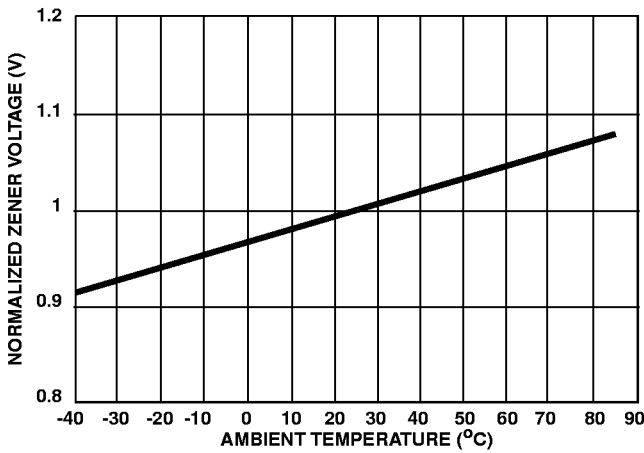

FIGURE 3. NORMALIZED ZENER VOLTAGE vs TEMPERATURE FOR ALL TYPES

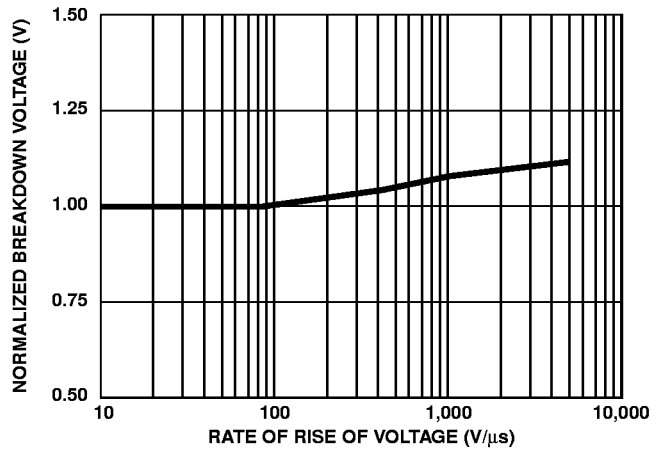

FIGURE 4. NORMALIZED V_{BO} vs dv/dt FOR ALL TYPES

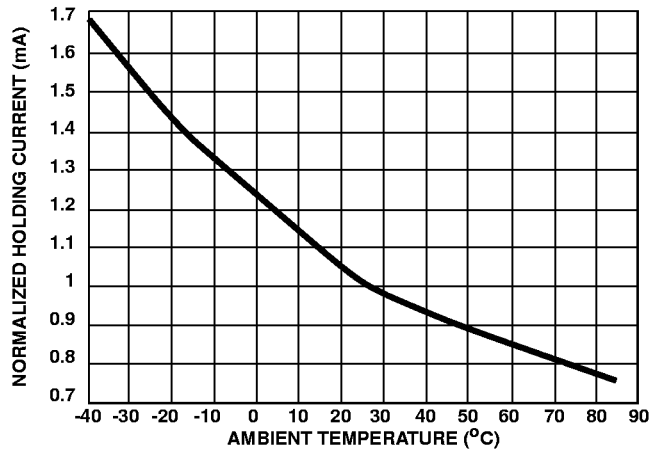
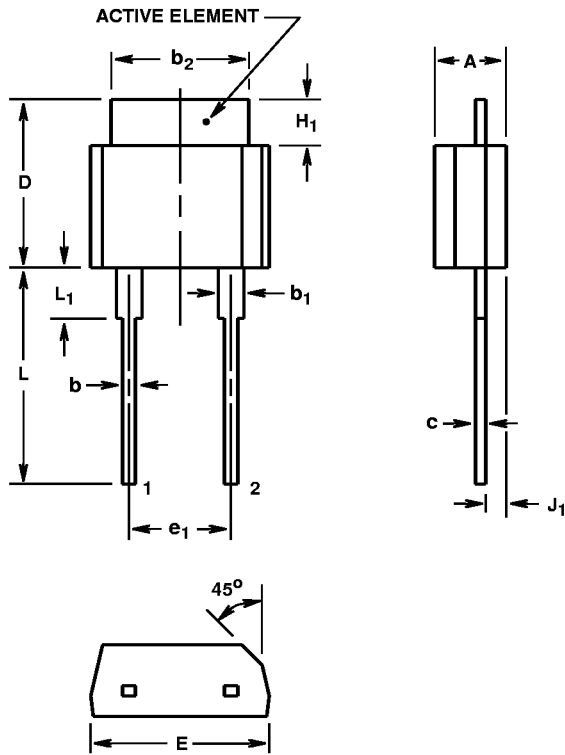

FIGURE 5. NORMALIZED HOLDING CURRENT vs TEMPERATURE FOR ALL TYPES

SGT2XB13, SGT2XB13A, SGT27B13B

Mechanical Dimensions



TO-202 Modified

2 LEAD JEDEC STYLE TO-202 SHORT TAB PLASTIC PACKAGE

SYMBOL	INCHES		MILLIMETERS		NOTES
	MIN	MAX	MIN	MAX	
A	0.130	0.150	3.31	3.81	-
b	0.024	0.028	0.61	0.71	2, 3
b ₁	0.045	0.055	1.15	1.39	1, 2, 3
b ₂	0.270	0.280	6.86	7.11	-
c	0.018	0.022	0.46	0.55	1, 2, 3
D	0.320	0.340	8.13	8.63	-
E	0.340	0.360	8.64	9.14	-
e ₁	0.200 BSC		5.08 BSC		4
H ₁	0.080	0.100	2.04	2.54	-
J ₁	0.039	0.049	1.00	1.24	5
L	0.410	0.440	10.42	11.17	-
L ₁	0.080	0.100	2.04	2.54	1

NOTES:

- Lead dimension and finish uncontrolled in L₁.
- Lead dimension (without solder).
- Add typically 0.002 inches (0.05mm) for solder coating.
- Position of lead to be measured 0.250 inches (6.35mm) from bottom of dimension D.
- Position of lead to be measured 0.100 inches (2.54mm) from bottom of dimension D.
- Controlling dimension: Inch.
- Revision 3 dated 10-94.

Nomenclature

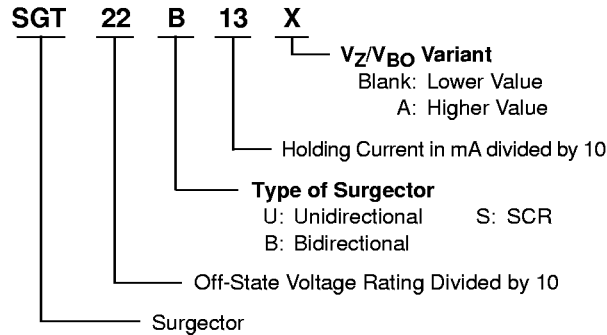

Terms and Symbols

V_{DM} (Maximum Off-State Voltage) - Maximum off-state voltage (DC or peak) which may be applied continuously.

V_{RM} (Maximum Reverse Voltage) - Maximum reverse-blocking voltage (DC or peak) which may be applied.

I_{TSM} (Maximum Peak Surge Current) - Maximum nonrepetitive current which may be allowed to flow for the time state.

T_A (Ambient Operating Temperature) - Ambient temperature range permitted during operation in a circuit.

T_{STG} (Storage Temperature) - Temperature range permitted during storage.

I_{DM} (Off-State Current) - Maximum value of off-state current that results from the application of the maximum off-state voltage (V_{DM}).

I_{RM} (Reverse Current) - Maximum value of reverse current that results from the application of the maximum reverse voltage (V_{RM}).

V_Z (Clamping Voltage) - Off-state voltage at a specified current.

V_{BO} (Breakdown Voltage) - Voltage at which the device switches from the off-state to the on-state.

I_H (Holding Current) - Minimum on-state current that will hold the device in the on-state after it has been latched on.

V_T (On-State Voltage) - Voltage across the main terminals for a specified on-state current.

C_O (Main Terminal Capacitance) - Capacitance between the main terminals at a specified off-state voltage.