

# Preliminary DATA SHEET

# DFB LASER DIODE LC AND SC TOSA

## DFB-1310-4X-XX

### FEATURES:

- Uncooled DFB laser diode
- 10km or 30km applications
- LC TOSA or SC TOSA packages
- Packaged with monitor photodiode
- Includes optical isolator
- Modulation speeds up to 4Gbps

### APPLICATION

- Source for high-speed data-communication and telecommunication links
  - ◆ CATV, Satellite, and other analog fiber optic networks

The DFB-1310-4x-xx are designed to meet the challenges of high speed data and telecommunications applications over distances up to 20km over single mode optical fiber. In addition, these lasers are ideal for analog applications such as CATV and other video networks. The lasers are packaged in a hermetically sealed TO56 package and then packaged into a metal receptacle that is designed to meet very stringent optical wiggle requirements. The TOSA package includes a single stage optical isolator to minimize sensitivity to optical back reflections.



Part Number	Description
DFB-1310-4I-LC	DFB laser in LC TOSA with optical isolator for 10km applications
DFB-1310-4I-SC	DFB laser in SC TOSA with optical isolator for 10km applications
DFB-1310-4L-LC	DFB laser in LC TOSA with optical isolator for 30km applications
DFB-1310-4L-SC	DFB laser in SC TOSA with optical isolator for 30km applications

## ABSOLUTE MAXIMUM RATINGS

Parameter	Rating
Storage Temperature	-40°C to +85°C
Case Operating Temperature	-40°C to +85°C
Lead Solder Temperature	260°C, 10 seconds
Reverse Power Supply Voltage	5V
Peak Forward Continuous Current	100mA
ESD Exposure (Human Body Model)	200V <sup>1</sup>

<sup>1</sup>Heel and wrist straps must be used on a properly grounded workstation

**NOTICE:** Stresses greater than those listed under “Absolute Maximum Ratings” may cause permanent damage to the device. This is a stress rating only and functional operation of the device at these or any other conditions above those indicated in the operations section for extended periods of time may affect reliability.

**NOTICE:** The inherent design of this component causes it to be sensitive to electrostatic discharge (ESD). To prevent ESD-induced damage and/or degradation to equipment, take normal ESD precautions when handling this product



## ELECTRICAL-OPTICAL CHARACTERISTICS

Unless otherwise stated, all parameters are at  $T_{CASE} = 25^{\circ}C$ ,  $T_{RANGE, CASE} = -40$  to  $85^{\circ}C$ , 2.488 Gbps, PRBS 2<sup>31</sup>-1

Parameter	Test Conditions	Symbol	Min.	Typ.	Max.	Units	Notes
Threshold Current	$T = 25^{\circ}C$ $T = T_{RANGE}$	$I_{TH}$		10	20 40	mA	
Operating Current	$T = 25^{\circ}C$ $T = T_{RANGE}$	$I_{OP}$		45	70	mA	1
Modulation Current	$T = 25^{\circ}C$ $T = T_{RANGE}$	$I_{MOD}$		25	60	mA	ER~4.5dB ER~6.5dB
Output Power	$I_F = I_{OP}$	$L_{OP}$		-4.0		dBm	10km option, 2
				+2.5			30km option, 2
Slope Efficiency	$T = 25^{\circ}C, SMF$	$\eta$		0.025		mW/mA	10km option
				0.1			30km option
Extinction Ratio	$T = T_{RANGE}$			6.0	9.0	dB	3
LA (wiggle)		LA			1.5	dB	4
Wavelength	$T = 25^{\circ}C$	$\lambda$	1290		1330	nm	
Spectral Width	$T = T_{RANGE}$	$\Delta\lambda$			1.0	nm, rms	
Wavelength temperature coefficient	$T = T_{RANGE}$	$\Delta\lambda/\Delta T$			0.1	nm/ $^{\circ}C$	
Side Mode Suppression	$T = T_{RANGE}$	SMSR	30			dB	
Relative Intensity Noise	$I = I_{OP}, 20dB ORL,$ $0.1 < F < 5.5GHz$	$RIN_{20}$			-120	dB/Hz	5
Modulation Bandwidth	$I = I_{OP}, T = T_{RANGE}$ $I = I_{OP}, T = 25^{\circ}C$	$S_{21,3dB}$	4	6		GHz	
Rise / Fall Time		$T_r$			90	ps	6
		$T_f$			90		
Forward Voltage	$I = I_{OP}, T = T_{RANGE}$	$V_f$	1		1.3	V	
Laser Resistance	$I = I_{OP}, T = T_{RANGE}$	$R_L$	2	5	12	Ohms	7
Monitor Current	$T = 25^{\circ}C, I = I_{OP},$ $V_B = -2.5V$	$I_{MON}$	80		800	$\mu A$	
Tracking Error	$T = T_{RANGE}$	TE	-1.25		1.25	dB	8
Monitor Dark Current	$T = T_{RANGE}, V_B = -2.5V$	$I_D$			100	nA	
Monitor Diode Capacitance	$V_B = -2.5V$	$C_{MON}$			10	pF	
Optical Return Loss		ORL	12			dB	

## Notes:

- Operating current is the average bias current required to meet the ER, rise/fall, and bandwidth specifications. The target operating condition is 35 mA over threshold at high temperature, 30mA over threshold at RT.
- Other output power range is possible per customer request.
- TOSA would be capable of meeting other specifications when modulated over this ER range.
- Maximum change in power as fiber is rotated by 360°.
- Measured with an optical receiver with a 3.125 Gb/s filter
- Rise and fall times are measured 20-80%
- Resistance is measured between  $I_{TH} + 10mA$  and  $I_{TH} + 20mA$
- Tracking error is defined as the coupled power difference at  $T_{max}$  or  $T_{min}$  (relative to  $25^{\circ}C$ ) where the back monitor current,  $I_{mon}$ , is held constant at the value found at  $25^{\circ}C$  at  $I = I_{op}$ .

## PIN OUT

Number	Function
1	Case
2	LD Cathode
3	PD Anode
4	LD Anode / PD Cathode

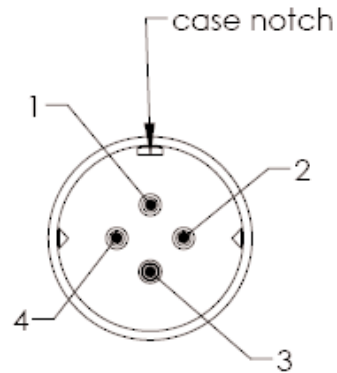

## MOUNTING DIMENSIONS

(for reference only): Dimensions in millimeters

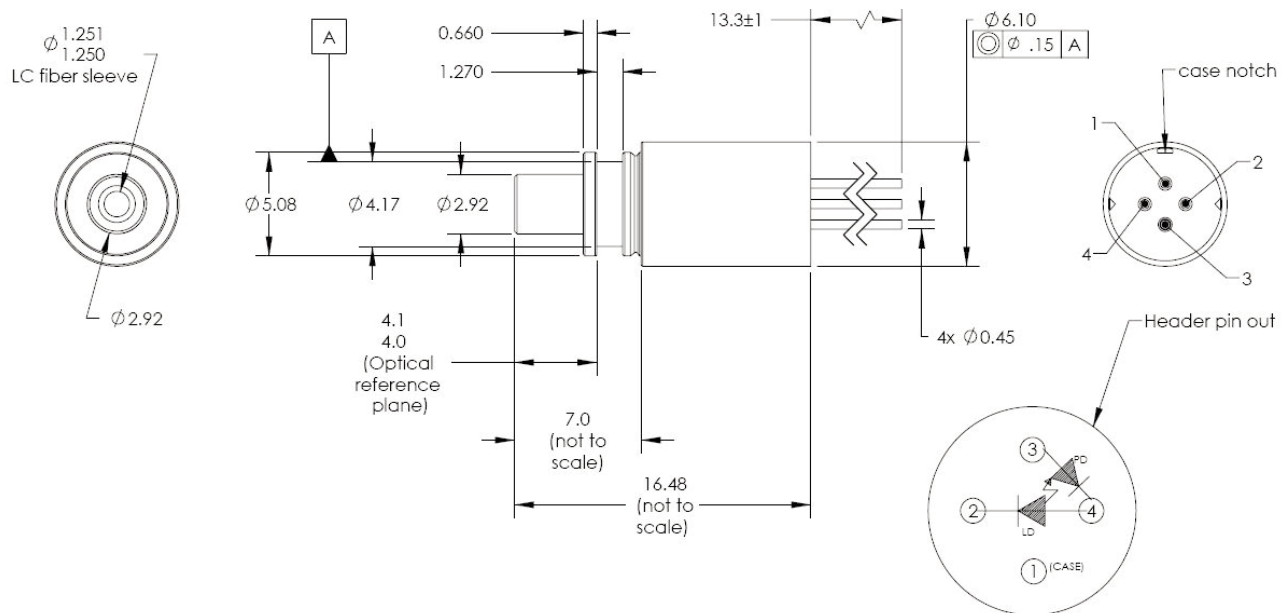

## ADVANCED OPTICAL COMPONENTS

Finisar's ADVANCED OPTICAL COMPONENTS division was formed through strategic acquisition of key optical component suppliers. The company has led the industry in high volume Vertical Cavity Surface Emitting Laser (VCSEL) and associated detector technology since 1996. VCSELs have become the primary laser source for optical data communication, and are rapidly expanding into a wide variety of sensor applications. VCSELs' superior reliability, low drive current, high coupled power, narrow and circularly symmetric beam and versatile packaging options (including arrays) are enabling solutions not possible with other optical technologies. ADVANCED OPTICAL COMPONENTS is also a key supplier of Fabrey-Perot (FP) and Distributed Feedback (DFB) Lasers, and Optical Isolators (OI) for use in single mode fiber data and telecommunications networks

## LOCATION

- Allen, TX - Business unit headquarters, VCSEL wafer growth, wafer fabrication and TO package assembly.
- Fremont, CA – Wafer growth and fabrication of 1310 to 1550nm FP and DFB lasers.
- Shanghai, PRC – Optical passives assembly, including optical isolators and splitters.

## SALES AND SERVICE

Finisar's ADVANCED OPTICAL COMPONENTS division serves its customers through a worldwide network of sales offices and distributors. For application assistance, current specifications, pricing or name of the nearest Authorized Distributor, contact a nearby sales office or call the number listed below.

***Finisar***  
Advanced Optical Components Division

**Phone:** 1-866-MY-VCSEL USA (toll free)  
1-214-509-2700 USA (Direct dial)  
44 (0) 174 336 5533 Europe  
886-935-409898 China & Taiwan  
81-90-4437-1130 Japan  
82-11-220-6153 Asia Pacific & Korea

**Fax:** 1-214-509-3709 USA

Email: [salesAOCD@finisar.com](mailto:salesAOCD@finisar.com)  
WEB: [www.finisar.com/aoc.php](http://www.finisar.com/aoc.php)

## AOC CAPABILITIES

ADVANCED OPTICAL COMPONENTS' advanced capabilities include:

- 1, 2, 4, 8, and 10Gbps serial VCSEL solutions
- 1, 2, 4, 8, and 10Gbps serial SW DETECTOR solutions
- VCSEL and detector arrays
- 1, 2, 4, 8, and 10Gbps FP and DFB solutions at 1310 and 1550nm
- 1, 2, 4, 8, and 10Gbps serial LW DETECTOR solutions
- Optical Isolators from 1260 to 1600nm range
- Laser packaging in TO46, TO56, and Optical subassemblies with SC, LC, and MU interfaces for communication networks
- VCSELs operating at 670nm, 780nm, 980nm, and 1310nm in development
- Sensor packages include surface mount, various plastics, chip on board, chip scale packages, etc.
- Custom packaging options