

# MN4028B/MN4028BS

## BCD-to-Decimal/Binary-to-Octal Decoder

### ■ Outline

The MN4028B/S is a decoder to convert a BDC signal into a decimal signal.

Of ten outputs of  $O_0 \sim O_9$ , those corresponding to the input codes for  $A_0 \sim A_3$  become the "H" level, and all the other outputs become the "L" level.

It is also possible to use this MN4028B/S as a 1-OF-8 decoder by using the input  $A_0 \sim A_2$ .

This decoder is equivalent to Motorola's MC14028B and RCA's CD4028B.

### ■ Logic Diagram

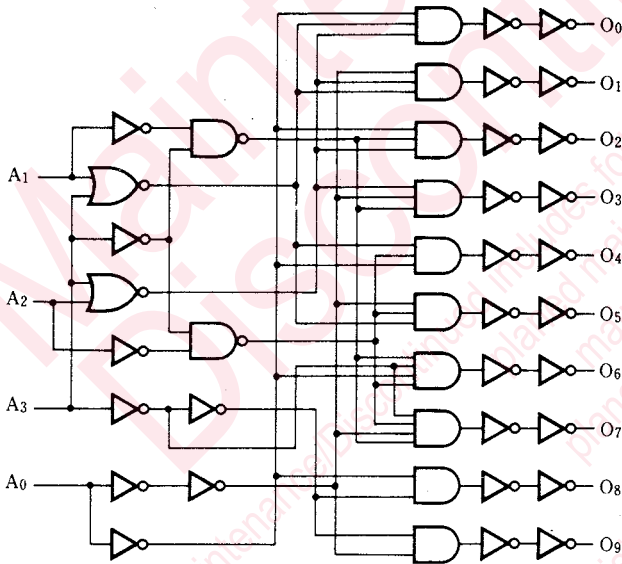

P-3

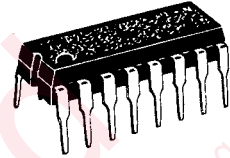

16-pin plastic DIL package

P-4



16-pin PANAFLAT package (SO-16D)

### Pin Configuration

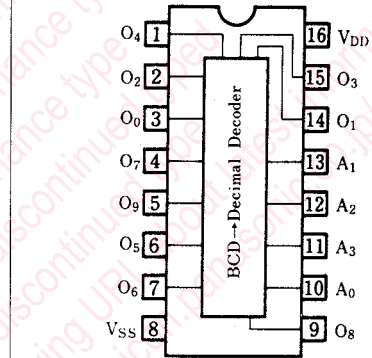

### Pin description

$A_0 \sim A_3$  : Address input 1-2-4-BCD

$O_0 \sim O_9$  : Output

■ Truth Table

Input				Output									
A <sub>3</sub>	A <sub>2</sub>	A <sub>1</sub>	A <sub>0</sub>	O <sub>0</sub>	O <sub>1</sub>	O <sub>2</sub>	O <sub>3</sub>	O <sub>4</sub>	O <sub>5</sub>	O <sub>6</sub>	O <sub>7</sub>	O <sub>8</sub>	O <sub>9</sub>
L	L	L	L	H	L	L	L	L	L	L	L	L	L
L	L	L	H	L	H	L	L	L	L	L	L	L	L
L	L	H	L	L	L	H	L	L	L	L	L	L	L
L	L	H	H	L	L	L	H	L	L	L	L	L	L
L	H	L	L	L	L	L	L	H	L	L	L	L	L
L	H	L	H	L	L	L	L	L	H	L	L	L	L
L	H	H	L	L	L	L	L	L	L	H	L	L	L
L	H	H	H	L	L	L	L	L	L	L	H	L	L
H	L	L	L	L	L	L	L	L	L	L	L	H	L
H	L	L	H	L	L	L	L	L	L	L	L	L	H
H	L	H	L	L	L	L	L	L	L	L	L	H	L
H	L	H	H	L	L	L	L	L	L	L	L	L	H
H	H	L	L	L	L	L	L	L	L	L	L	H	L
H	H	L	H	L	L	L	L	L	L	L	L	L	H
H	H	H	L	L	L	L	L	L	L	L	L	H	L
H	H	H	H	L	L	L	L	L	L	L	L	L	H

■ Absolute Maximum Ratings (Ta=25°C)

Item	Symbol	Rating	Unit
Supply voltage	V <sub>DD</sub>	-0.5~+18	V
Input voltage	V <sub>I</sub>	-0.5~V <sub>DD</sub> +0.5*	V
Output pin voltage	V <sub>O</sub>	-0.5~V <sub>DD</sub> +0.5*	V
Peak input · output pin current	±I <sub>I</sub>	max. 10	mA
Power dissipation (per package)	Ta = -40~+60°C	max. 400	mW
	Ta = +60~+80°C	Decrease to 200mW at the rate of 8mW/°C	
Power dissipation (per output pin)	P <sub>D</sub>	max. 100	mW
Operating ambient temperature	T <sub>opr</sub>	-40~+85	°C
Storage temperature	T <sub>stg</sub>	-65~+150	°C

\* V<sub>DD</sub>+0.5V should be lower than 18V.

■ DC Characteristics (V<sub>SS</sub>=0V)

Item	V <sub>DD</sub> (V)	Symbol	Condition	Ta = -40°C		Ta = 25°C		Ta = 85°C		Unit
				min.	max.	min.	max.	min.	max.	
Static supply current	5	I <sub>DD</sub>	V <sub>I</sub> =V <sub>SS</sub> or V <sub>DD</sub>	—	20	—	20	—	150	μA
	10			—	40	—	40	—	300	
	15			—	80	—	80	—	600	
Output voltage low level	5	V <sub>OL</sub>	V <sub>I</sub> =V <sub>SS</sub> or V <sub>DD</sub>  I <sub>O</sub>  <1μA	—	0.05	—	0.05	—	0.05	V
	10			—	0.05	—	0.05	—	0.05	
	15			—	0.05	—	0.05	—	0.05	
Output voltage high level	5	V <sub>OH</sub>	V <sub>I</sub> =V <sub>SS</sub> or V <sub>DD</sub>  I <sub>O</sub>  <1μA	4.95	—	4.95	—	4.95	—	V
	10			9.95	—	9.95	—	9.95	—	
	15			14.95	—	14.95	—	14.95	—	

■ DC Characteristics ( $V_{SS}=0V$ )

Item	$V_{DD}$ (V)	Symbol	Condition	$T_a=-40^{\circ}C$		$T_a=25^{\circ}C$		$T_a=85^{\circ}C$		Unit
				min.	max.	min.	max.	min.	max.	
Input voltage low level	5	$V_{IL}$	$ I_{OL}  < 1\mu A$ $V_O=0.5V$ or $4.5V$	—	1.5	—	1.5	—	1.5	V
	10			—	3	—	3	—	3	
	15			—	4	—	4	—	4	
Input voltage high level	5	$V_{IH}$	$ I_{OL}  < 1\mu A$ $V_O=0.5V$ or $4.5V$	3.5	—	3.5	—	3.5	—	V
	10			7	—	7	—	7	—	
	15			11	—	11	—	11	—	
Output current low level	5	$I_{OL}$	$V_O=0.4V, V_I=0$ or $5V$ $V_O=0.5V, V_I=0$ or $10V$ $V_O=1.5V, V_I=0$ or $15V$	0.52	—	0.44	—	0.36	—	mA
	10			1.3	—	1.1	—	0.9	—	
	15			3.6	—	3	—	2.4	—	
Output current high level	5	$-I_{OH}$	$V_O=4.6V, V_I=0$ or $5V$ $V_O=9.5V, V_I=0$ or $10V$ $V_O=13.5V, V_I=0$ or $15V$	0.52	—	0.44	—	0.36	—	mA
	10			1.3	—	1.1	—	0.9	—	
	15			3.6	—	3	—	2.4	—	
Output current high level	5	$-I_{OH}$	$V_O=2.5V, V_I=0$ or $5V$	1.7	—	1.4	—	1.1	—	mA
Input leakage current	15	$\pm I_I$	$V_I=0$ or $15V$	—	0.3	—	0.3	—	1	$\mu A$

■ Switching Characteristics ( $T_a=25^{\circ}C, V_{SS}=0V, C_L=50pF$ )

Item	$V_{DD}(V)$	Symbol	min.	typ.	max.	Unit
Output rise time	5	$t_{TLH}$	—	60	180	ns
	10		—	30	90	
	15		—	20	60	
Output fall time	5	$t_{THL}$	—	60	180	ns
	10		—	30	90	
	15		—	20	60	
Propagation time	5	$t_{PLH}$	—	100	300	ns
	10		—	45	135	
	15		—	30	90	
Propagation time	5	$t_{PHL}$	—	110	330	ns
	10		—	50	150	
	15		—	35	105	
Input capacitance		$C_I$	—	—	7.5	pF

1. Switching time measuring circuit

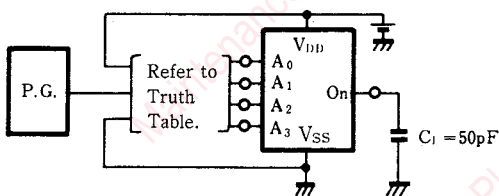

2. Switching waveforms

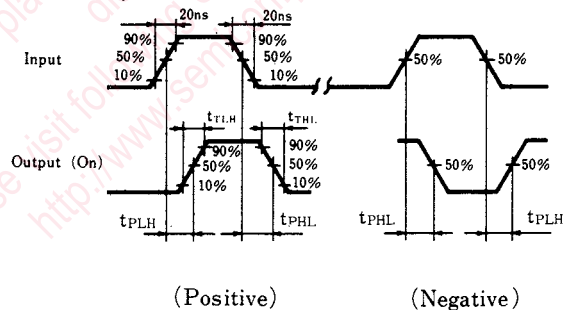

(Positive)

(Negative)

## Request for your special attention and precautions in using the technical information and semiconductors described in this book

- (1) If any of the products or technical information described in this book is to be exported or provided to non-residents, the laws and regulations of the exporting country, especially, those with regard to security export control, must be observed.
- (2) The technical information described in this book is intended only to show the main characteristics and application circuit examples of the products. No license is granted in and to any intellectual property right or other right owned by Panasonic Corporation or any other company. Therefore, no responsibility is assumed by our company as to the infringement upon any such right owned by any other company which may arise as a result of the use of technical information described in this book.
- (3) The products described in this book are intended to be used for standard applications or general electronic equipment (such as office equipment, communications equipment, measuring instruments and household appliances).  
Consult our sales staff in advance for information on the following applications:
  - Special applications (such as for airplanes, aerospace, automobiles, traffic control equipment, combustion equipment, life support systems and safety devices) in which exceptional quality and reliability are required, or if the failure or malfunction of the products may directly jeopardize life or harm the human body.
  - Any applications other than the standard applications intended.
- (4) The products and product specifications described in this book are subject to change without notice for modification and/or improvement. At the final stage of your design, purchasing, or use of the products, therefore, ask for the most up-to-date Product Standards in advance to make sure that the latest specifications satisfy your requirements.
- (5) When designing your equipment, comply with the range of absolute maximum rating and the guaranteed operating conditions (operating power supply voltage and operating environment etc.). Especially, please be careful not to exceed the range of absolute maximum rating on the transient state, such as power-on, power-off and mode-switching. Otherwise, we will not be liable for any defect which may arise later in your equipment.
  - Even when the products are used within the guaranteed values, take into the consideration of incidence of break down and failure mode, possible to occur to semiconductor products. Measures on the systems such as redundant design, arresting the spread of fire or preventing glitch are recommended in order to prevent physical injury, fire, social damages, for example, by using the products.
- (6) Comply with the instructions for use in order to prevent breakdown and characteristics change due to external factors (ESD, EOS, thermal stress and mechanical stress) at the time of handling, mounting or at customer's process. When using products for which damp-proof packing is required, satisfy the conditions, such as shelf life and the elapsed time since first opening the packages.
- (7) This book may be not reprinted or reproduced whether wholly or partially, without the prior written permission of our company.