

DF62 Series

Slim In-Line/THT Connectors



Positive-Lock



Wide Variation



Slim In-Line

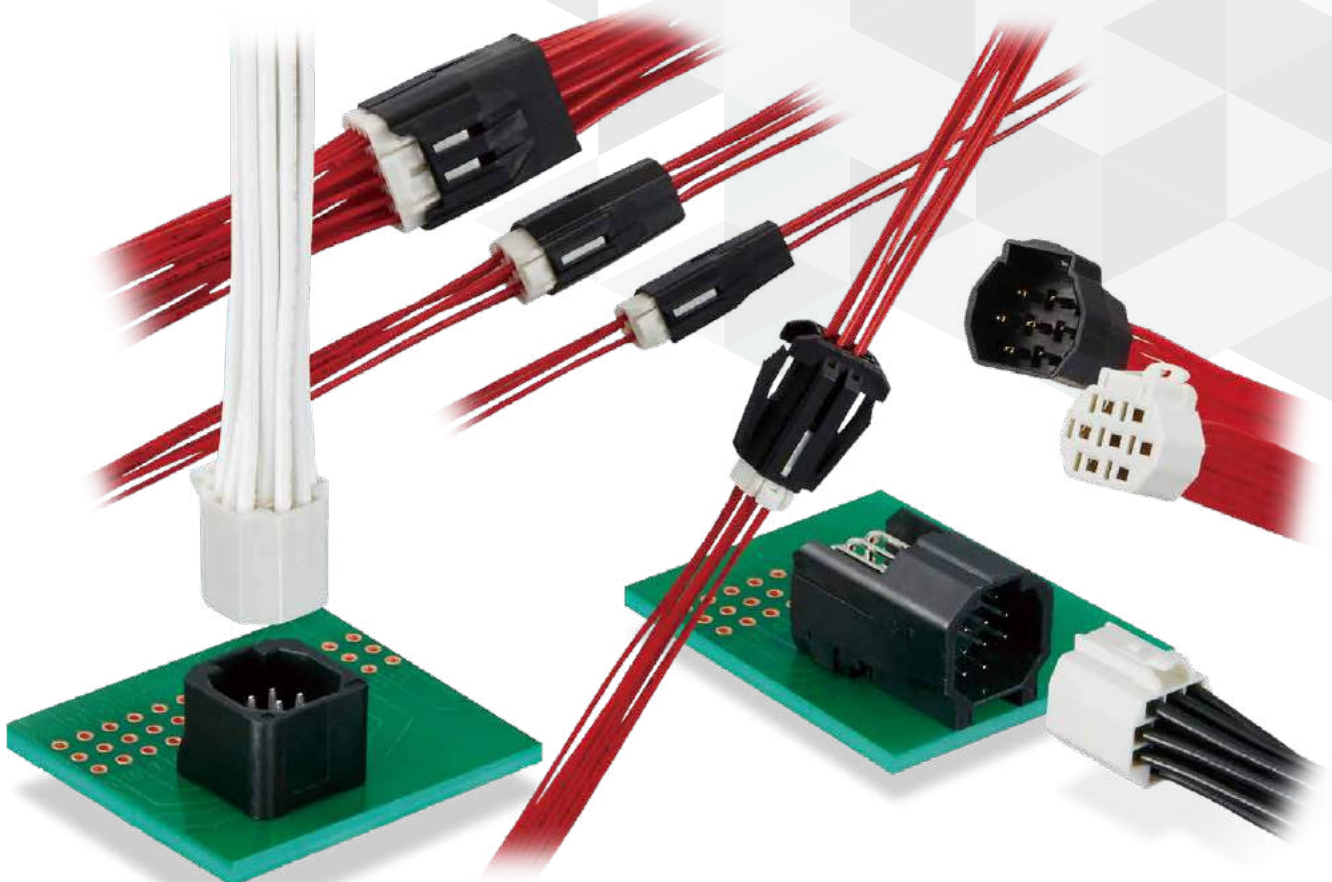

Dec.1.2022 Copyright 2022 HIROSE ELECTRIC CO., LTD. All Rights Reserved.

Features

1. The slim, sleek design and smooth contour combine to complete connections in tight spaces.

These connectors were designed to take full advantage of small/ narrow spaces. The contacts are arranged in a grid pattern which shortens the diagonal distances and the body was slimmed down by creating smooth outer surfaces. This design helps to save precious space and makes these connectors virtually tangle free. There is no visible or exposed metal which eliminates the possibility of electrical arcing between the connector and the inside of a metal conduit.

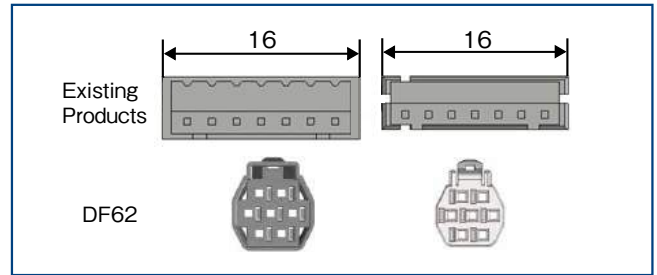

Compact shape due to 2 × 2. 2 grid layout of pins
(Both are 7 contacts with 3A current rating)

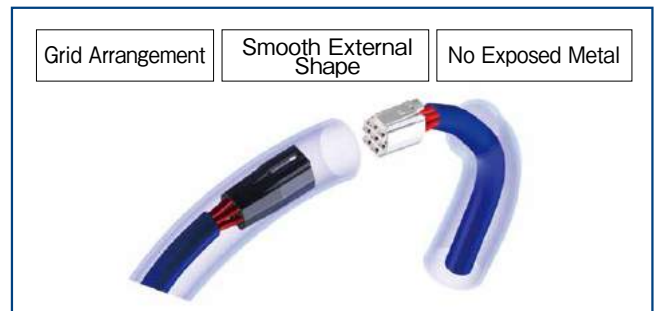

2. Secure Lock Mechanism

The friction lock emits a clear tactile click upon lock completion. The design prevents incomplete mating and connector disconnection. The socket lock can be visually checked through the plug window after mating. These indicators function together to prevent incomplete mating.

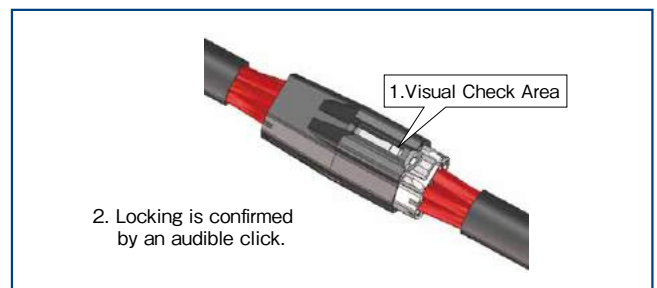

3. Reliable Contact Design

Two-point contact design that maintains contact reliability.

4. Robust Contact Design

The unique design provides protection to the contacts and lance areas and it prevents any bending or deformity that might occur during mating, assembly or transportation.

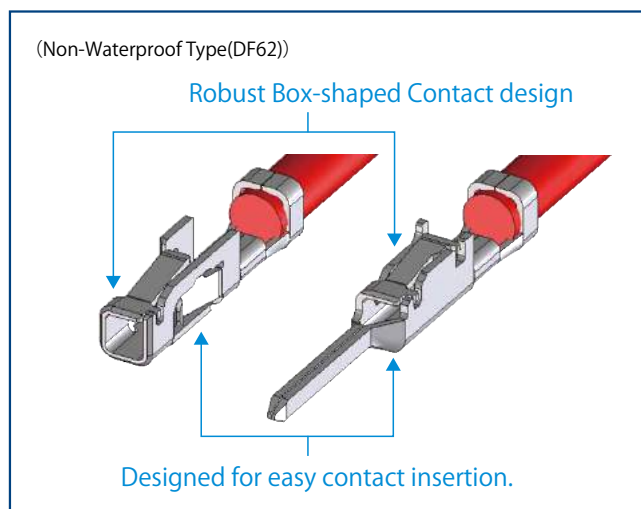

5. Multiple Variations Available

There are several different wire counts available, giving the designer a wide variety to choose from for the application.

Protected lock type, panel mount type and pin header type are also available.

6. Applicator Sharing

The applicators for the DF11 and DF59 Series (existing products) can be adapted to accommodate the DF62 Series applicators.

Note 1 : The DF11 Series applicators require part replacement in order to handle the difference in contact length.

However once replaced the applicator can be used with DF11, DF59 and DF62.

Note 2 : The die and hand tool are used only for the in designated purposes.

Note 3 : Please contact Hirose for additional details.

Product Specifications

Rated Current (Note 1)	No of Pos.	22 AWG	24 AWG	26-30 AWG	Operating Temperature (Note 2)	-35 to +105°C
	2	4A/pin	2A/pin	1A/pin	Storage Temperature Range (Note 4)	-10 to +60°C
	3	3A/pin	2A/pin	1A/pin	Operating Humidity Range (Note 3)	20 to 80%
	4	3A/pin	2A/pin	1A/pin	Storage Humidity Range (Note 4)	40 to 70%
	5	3A/pin	2A/pin	1A/pin		
	6	3A/pin	2A/pin	1A/pin		
	7	3A/pin	2A/pin	1A/pin		
	13	3A/pin	2A/pin	1A/pin		
	24	2.5A/pin	2A/pin	1A/pin		
Rated Voltage	250V AC/DC					

UL, C-UL	Rated Voltage	29.9V AC/DC	Operating Temperature (Note 2)	-35 to +75°C
----------	---------------	-------------	--------------------------------	--------------

UL, C-UL File Name
 UL : E52653
 C-UL : E52653

Items	Specifications	Conditions
Insulation Resistance	1000M Ω Min.	500V DC
Withstanding Voltage	No flashover or insulation breakdown	650V AC for 1 min.
Contact Resistance	30m Ω Max.	20mV Max., 1mA (DC or 1000Hz)
Vibration Resistance	No electrical discontinuity of 1 μ s.	10 cycles in each of three directions at frequency 10 to 55Hz, half amplitude 0.75mm
Shock Resistance	No electrical discontinuity of 1 μ s.	Accelerated velocity : 490 m/s ² for 11ms, half-sine wave in 3 directions, 3 times for each direction
Humidity Resistance	Contact Resistance : 30m Ω Max. Insulation Resistance : 1000M Ω Min.	96 hours at temperature of +40 \pm 2°C and humidity of 90 to 95%
Temperature Cycles	Contact Resistance : 30m Ω Max. Insulation Resistance : 1000M Ω Min.	-55°C : 30 minutes \rightarrow 5 to 35°C : 2 to 3 minutes \rightarrow 85°C : 30 minutes \rightarrow 5 to 35°C : 2 to 3 minutes, 5 cycles
Mating Durability	Contact Resistance : 30m Ω Max.	30 times
Solder Heat Resistance	No deformation in appearance or significant damage to contacts.	Flow : 260°C, 10sec. Hand soldering : temperature of soldering iron at 300°C for 3sec.

Note 1 : This is the maximum current rating while all pins are powered or used as all power lines.
 When isolating power lines into multiple circuits, current ratings may go above the stated current ratings. Please consult Hirose for details before doing this.

Note 2 : Includes temperature rise caused by current flow.

Note 3 : The connector should be completely dry (no condensation present)

Note 4 : Applicable to unused items in packed condition.

Note 5 : Information contained in this catalog represents general requirements for this Series.
 Contact us for the drawings and specifications for a specific part number shown.

Materials / Finish

Item	Component	Material	Finish	UL Flame Retardant Grade	RoHS2
Socket Crimping Contact	Contact	Phosphorous Bronze	Gold Plating or Tin Plating	-	Yes
Plug Crimping Contact				-	
Crimping Socket	Insulator	PBT	White, Black or Red	UL94V-0	
Crimping Plug					
Header	Insulator	Straight : Polyamide	Black	UL94V-0	
		Right Angle : PBT			
	Contact	Copper Alloy	Gold Plating or Tin Plating	-	
	Retention Tab	Brass	Tin Plating	-	

Product Number Structure

Refer to the chart below when determining the product specifications from the product number.
Please select from the product numbers listed in this catalog when placing orders.

Note : The waterproof type (DF62W Series) and non-waterproof type (DF62 Series) are not interchangeable.

● Connector

DF62B - # S - 2.2 C (##)

① ② ③ ④ ⑤ ⑥

① Series Name	DF62B (Regular Type) DF62C (Protected Lock Type) DF62P (Panel Mount Type)	④ Contact Pitch	2.2mm
② No. of Pos.	2, 3, 4, 5, 6, 7, 13, 24	⑤ Connection Part	C : Crimping Housing
③ Connector Type	S : Socket EP : In-line Plug	⑥ Color	Socket (None : White, 11 : Black, 18 : Red) In-line Plug (None : Black, 10 : White, 18 : Red)

● Contact

DF62 - EP 2428 PCF A

① ② ③ ④ ⑤

① Series Name	DF62	④ Contact Type / Packaging Type	SCF : Socket crimping contact, reel SC : Socket crimping contact, pieces PCF : Plug crimping contact, reel PC : Plug crimping contact, pieces
② Terminal Type	EP : In-line Plug		
③ Applicable Wire Size	22 : 22 AWG 2428 : 24 to 28 AWG 30 : 30 AWG	⑤ Plating Type	A : Gold plating None : Tin plating

● Connector

DF62 - # P - 2.2 DSA (##)

① ② ③ ④ ⑤ ⑥

① Series Name	DF62	④ Contact Pitch	2.2mm
② No. of Pos.	13, 24	⑤ Connection Part Shape	DSA : Straight Pin Header DS : Right Angle Pin Header
③ Connector Type	P : Pin Header	⑥ Plating Type	None : Tin Plating 01 : Gold Plating

Diagram of Connector Mating Combinations

Crimping Socket (Note)	Socket Crimping Contact
DF62B-#S-2.2C	DF62-22SC(F)(A)
DF62C-#S-2.2C	DF62-2428SC(F)(A)
	DF62-30SC(F)(A)

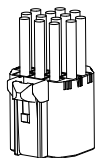

Crimping Plug (Note)	Plug Crimping Contact
DF62B-#EP-2.2C	DF62-EP22PC(F)(A)
DF62P-#EP-2.2C	DF62-EP2428PC(F)(A)
	DF62-EP30PC(F)(A)

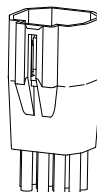

Straight Pin Header
DF62-#P-2.2DSA

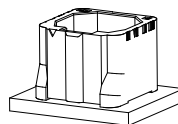

Right Angle Pin Header
DF62-#P-2.2DS

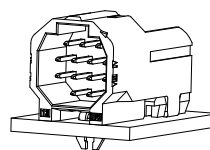

Dec. 1. 2022 Copyright 2022 HIROSE ELECTRIC CO., LTD. All Rights Reserved.

Socket (Standard Type)

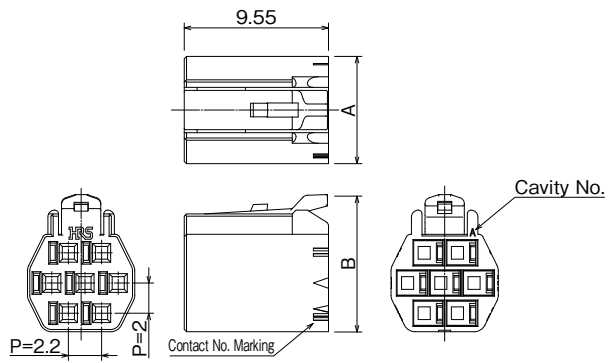

7pos. shown as an example.

Unit : mm

Part No.	HRS No.	No. of Pos.	A	B	Purchase Unit
DF62B-2S-2.2C(##)	CL0544-0551-0-##	2	4.9	5.08	100pcs per bag
DF62B-3S-2.2C(##)	CL0544-0552-2-##	3			
DF62B-4S-2.2C(##)	CL0544-0553-5-##	4			
DF62B-5S-2.2C(##)	CL0544-0554-8-##	5	7.1	7.08	
DF62B-6S-2.2C(##)	CL0544-0555-0-##	6			
DF62B-7S-2.2C(##)	CL0544-0556-3-##	7			
DF62B-13S-2.2C(##)	CL0544-0557-6-##	13	9.3	11.08	
DF62B-24S-2.2C(##)	CL0544-0539-4-##	24	12.3	13.08	

[Specification No.] -##.(##)

None : White

(11) : Black

(18) : Red

Socket (Protected Lock Type)

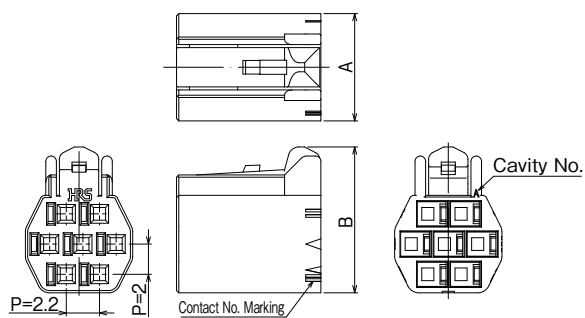

7pos. shown as an example.

Unit : mm

Part No.	HRS No.	No. of Pos.	A	B	Purchase Unit
DF62C-2S-2.2C(##)	CL0544-0565-4-##	2	4.9	5.65	100pcs per bag
DF62C-3S-2.2C(##)	CL0544-0566-7-##	3		7.65	
DF62C-4S-2.2C(##)	CL0544-0567-0-##	4			
DF62C-5S-2.2C(##)	CL0544-0568-2-##	5	7.1	9.65	
DF62C-6S-2.2C(##)	CL0544-0569-5-##	6			
DF62C-7S-2.2C(##)	CL0544-0570-4-##	7			
DF62C-13S-2.2C(##)	CL0544-0571-7-##	13	9.3	11.65	
DF62C-24S-2.2C(##)	CL0544-0541-6-##	24	12.3	13.65	

[Specification No.] -##,(##)

None : White

(11) : Black

(18) : Red

Plug (Standard Type)

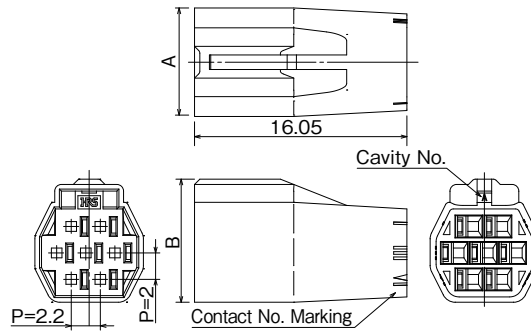
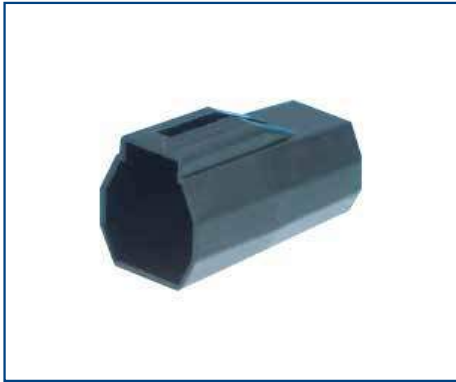

7pos. shown as an example.

Unit : mm

Part No.	HRS No.	No. of Pos.	A	B	Purchase Unit
DF62B-2EP-2.2C(##)	CL0544-0558-9-##	2	6.0	5.3	100pcs per bag
DF62B-3EP-2.2C(##)	CL0544-0559-1-##	3			
DF62B-4EP-2.2C(##)	CL0544-0560-0-##	4			
DF62B-5EP-2.2C(##)	CL0544-0561-3-##	5	8.2	7.3	
DF62B-6EP-2.2C(##)	CL0544-0562-6-##	6			
DF62B-7EP-2.2C(##)	CL0544-0563-9-##	7			
DF62B-13EP-2.2C(##)	CL0544-0564-1-##	13	10.4	11.3	
DF62B-24EP-2.2C(##)	CL0544-0540-3-##	24	13.4	13.3	

[Specification No.] -##,(##)

None : Black

(10) : White

(18) : Red

Plug (Panel Mount Type)

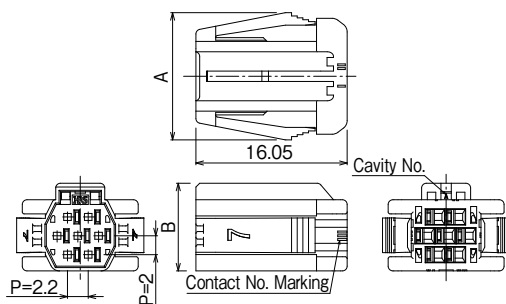

Unit : mm

Part No.	HRS No.	No. of Pos.	A	B	Purchase Unit
DF62P-2EP-2.2C(##)	CL0544-0543-1-##	2	11.3	5.3	100pcs per bag
DF62P-3EP-2.2C(##)	CL0544-0544-4-##	3			
DF62P-4EP-2.2C(##)	CL0544-0545-7-##	4			
DF62P-5EP-2.2C(##)	CL0544-0546-0-##	5	13.5	7.3	
DF62P-6EP-2.2C(##)	CL0544-0547-2-##	6			
DF62P-7EP-2.2C(##)	CL0544-0548-5-##	7			
DF62P-13EP-2.2C(##)	CL0544-0549-8-##	13	15.7	11.3	
DF62P-24EP-2.2C(##)	CL0544-0550-7-##	24	18.7	13.3	

[Specification No.] -##,(##)

None : Black

(10) : White

(18) : Red

■ Socket Position Number Pin Configuration (Shown from the Mating Side)

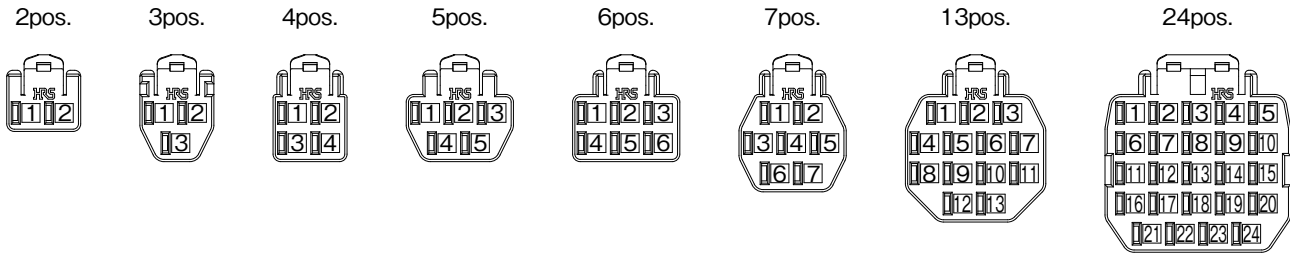

■ Plug Position Number Pin Configuration (Shown from the Mating Side)

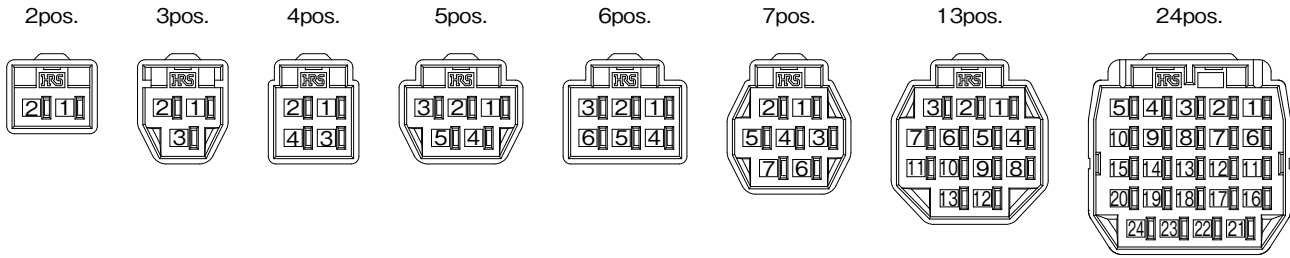

■ Position No. Diagram

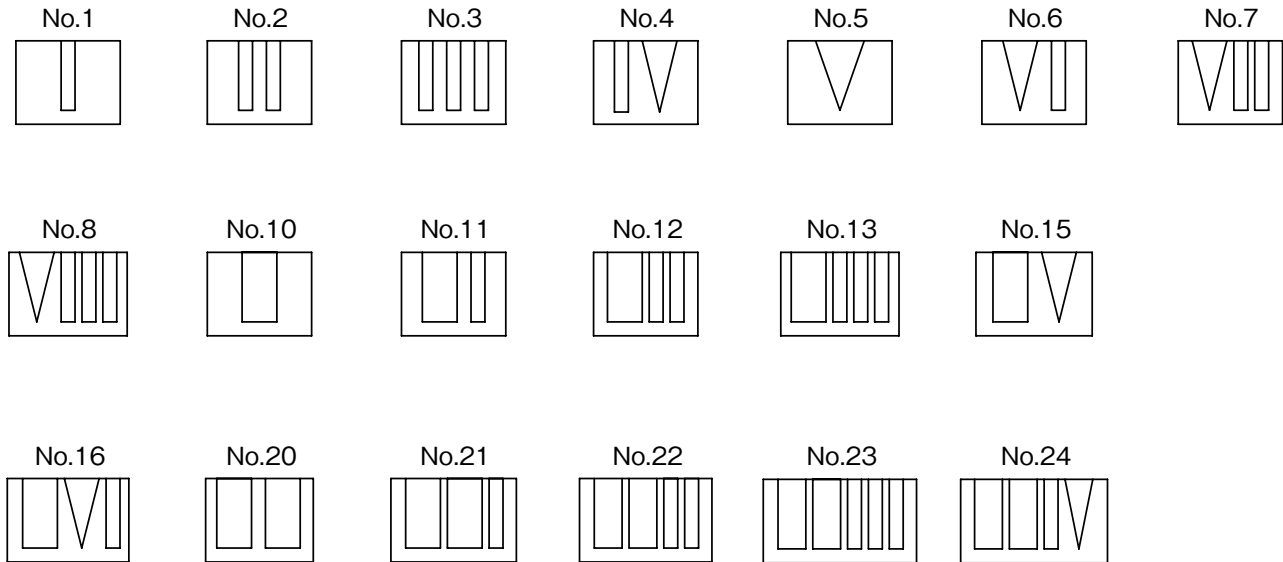

Socket Crimping Contact

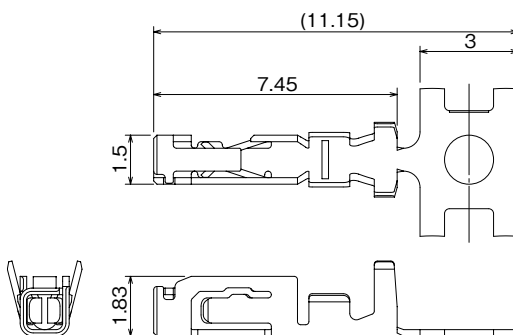

● Reel Contact, Applicable Tool : Applicator

Part No.	HRS No.	Finish	Applicable Wire (Tin Plated Annealed Copper) (Note)					Purchase Unit
			UL	AWG	Stranded Wire Structure	Calculated Cross-section	Jacket Diameter	
DF62-22SCF DF62-22SCFA	CL0544-0520-6-00 CL0544-0506-5-00	Tin Plated Gold Plated	1061	22	17/0.16mm	0.342mm ²	φ 1.2 to φ 1.45mm	15,000pcs per reel
DF62-2428SCF DF62-2428SCFA	CL0544-0521-9-00 CL0544-0500-9-00	Tin Plated Gold Plated	1007	24 26 28	11/0.16mm 7/0.16mm 7/0.127mm	0.221mm ² 0.141mm ² 0.089mm ²	φ 0.9 to φ 1.45mm	
DF62-30SCF DF62-30SCFA	CL0544-0522-1-00 CL0544-0508-0-00	Tin Plated Gold Plated	1007	30	7/0.1mm	0.055mm ²	φ 0.75 to φ 1.2mm	

Note: When using cables not specified by Hirose, please contact a Hirose sales representative.

● Loose Piece, Applicable Tool : Hand Crimping Tool

Part No.	HRS No.	Finish	Applicable Wire (Tin Plated Annealed Copper) (Note)					Purchase Unit
			UL	AWG	Stranded Wire Structure	Calculated Cross-section	Jacket Diameter	
DF62-22SC DF62-22SCA	CL0544-0572-0-00 CL0544-0526-2-00	Tin Plated Gold Plated	1061	22	17/0.16mm	0.342mm ²	φ 1.26mm	100pcs per bag
DF62-2428SC DF62-2428SCA	CL0544-0573-2-00 CL0544-0527-5-00	Tin Plated Gold Plated	1007	24 26 28	11/0.16mm 7/0.16mm 7/0.127mm	0.221mm ² 0.141mm ² 0.089mm ²	φ 1.42mm φ 1.28mm φ 1.18mm	
DF62-30SC DF62-30SCA	CL0544-0574-5-00 CL0544-0528-8-00	Tin Plated Gold Plated	1007	30	7/0.1mm	0.055mm ²	φ 0.82mm	

Note: The applicable cables include only those listed above.

Plug Crimping Contact

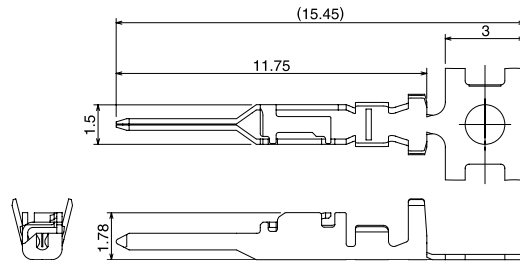

● Reel Contact, Applicable Tool : Applicator

Part No.	HRS No.	Finish	Applicable Wire (Tin Plated Annealed Copper) (Note)					Purchase Unit
			UL	AWG	Stranded Wire Structure	Calculated Cross-section	Jacket Diameter	
DF62-EP22PCF DF62-EP22PCFA	CL0544-0523-4-00 CL0544-0507-8-00	Tin Plated Gold Plated	1061	22	17/0.16mm	0.342mm ²	φ 1.2 to φ 1.45mm	15,000pcs per reel
DF62-EP2428PCF DF62-EP2428PCFA	CL0544-0524-7-00 CL0544-0501-1-00	Tin Plated Gold Plated	1007	24 26 28	11/0.16mm 7/0.16mm 7/0.127mm	0.221mm ² 0.141mm ² 0.089mm ²	φ 0.9 to φ 1.45mm	
DF62-EP30PCF DF62-EP30PCFA	CL0544-0525-0-00 CL0544-0509-3-00	Tin Plated Gold Plated	1007	30	7/0.1mm	0.055mm ²	φ 0.75 to φ 1.2mm	

Note: When using cables not specified by Hirose, please contact a Hirose sales representative.

● Loose Piece, Applicable Tool : Hand Crimping Tool

Part No.	HRS No.	Finish	Applicable Wire (Tin Plated Annealed Copper) (Note)					Purchase Unit
			UL	AWG	Stranded Wire Structure	Calculated Cross-section	Jacket Diameter	
DF62-EP22PC DF62-EP22PCA	CL0544-0575-8-00 CL0544-0529-0-00	Tin Plated Gold Plated	1061	22	17/0.16mm	0.342mm ²	φ 1.26mm	100pcs per bag
DF62-EP2428PC DF62-EP2428PCA	CL0544-0576-0-00 CL0544-0530-0-00	Tin Plated Gold Plated	1007	24 26 28	11/0.16mm 7/0.16mm 7/0.127mm	0.221mm ² 0.141mm ² 0.089mm ²	φ 1.42mm φ 1.28mm φ 1.18mm	
DF62-EP30PC DF62-EP30PCA	CL0544-0577-3-00 CL0544-0529-0-00	Tin Plated Gold Plated	1007	30	7/0.1mm	0.055mm ²	φ 0.82mm	

Note : The applicable cables include only those listed above.

Straight Pin Header

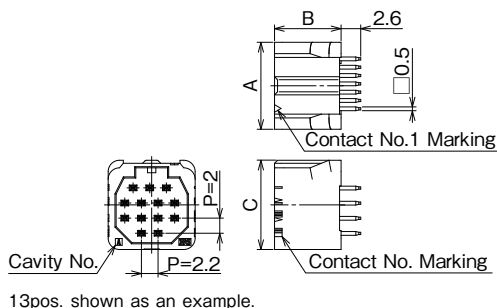

Unit : mm

Part No.	HRS No.	No. of Pos.	A	B	C	Tin Plating	Gold Plating	Purchase Unit
DF62-13P-2.2DSA(##)	CL0544-0582-0-##	13	11.5	8.8	11.8	Yes	—	100pcs per tray
DF62-24P-2.2DSA(##)	CL0544-0584-0-##	24	14.5	10.8	13.8	Yes	Yes	80pcs per tray

[Specification No.] -##.(##)

None : Tin Plating

(01) : Gold Plating

Note : Please contact a Hirose representative for requests on gold plating pin count variations that have not been released.

■ Recommended thickness of PCB: $t=1.6\pm 0.1$ mm

[13pos.]

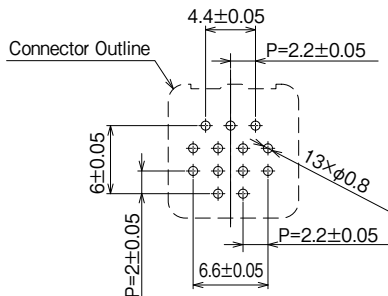

[24pos.]

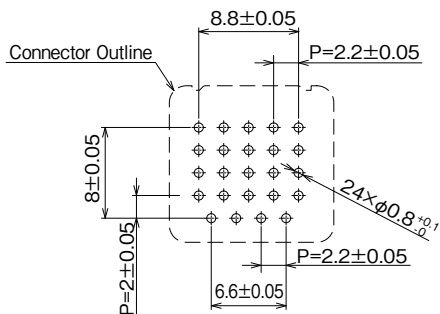

Right Angle Pin Header

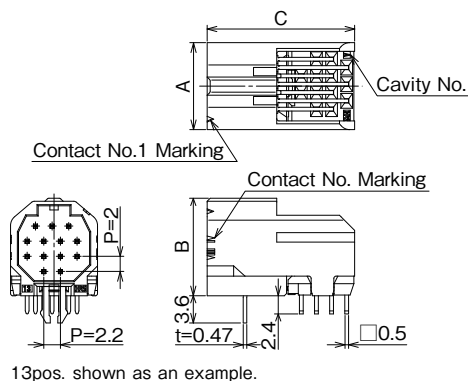

Unit : mm

Part No.	HRS No.	No. of Pos.	A	B	C	Tin Plating	Gold Plating	Purchase Unit
DF62-13P-2.2DS(##)	CL0544-0581-0-##	13	11.5	12.9	19.5	Yes	—	100pcs per tray
DF62-24P-2.2DS(##)	CL0544-0583-0-##	24	15.4	14.9	23.5	Yes	Yes	

[Specification No.] -##.(##)

None : Tin Plating

(01) : Gold Plating

Note : Please contact a Hirose representative for requests on gold plating pin count variations that have not been released.

Recommended thickness of PCB: $t=1.6\pm0.1$ mm

[13pos.]

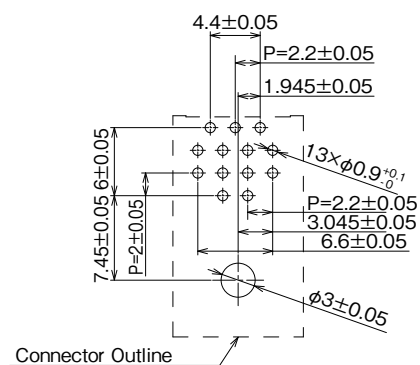

[24pos.]

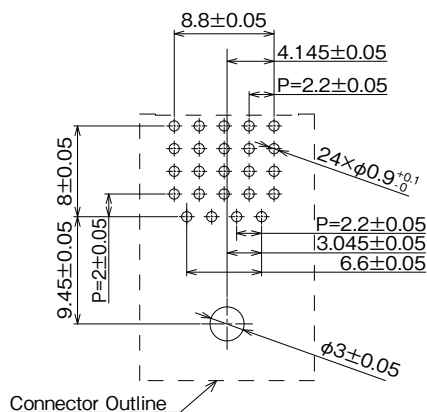

Mated Dimensions

● Wire-to-Wire Connection

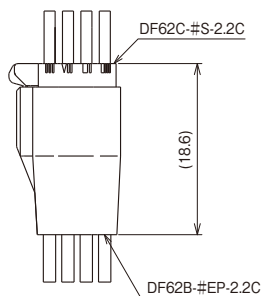

● Wire-to-Board Connection (Straight Pin Header)

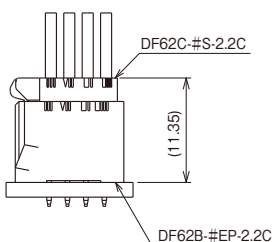

● Wire-to-Board Connection (Right Angle Pin Header)

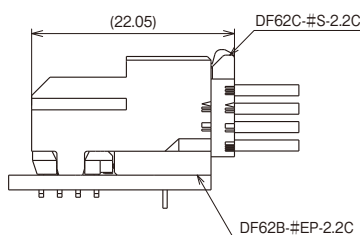

Applicable Crimping Tool

Tool	Part No.	HRS No.	Applicable Contact
Applicator	AP105-DF62-22	CL0901-4626-3-00	DF62-22SCFA/SCF DF62-EP22PCFA/PCF
	AP105-DF62-2428	CL0901-4625-0-00	DF62-2428SCFA/SCF DF62-EP2428PCFA/PCF
	AP105-DF62-30	CL0901-4627-6-00	DF62-30SCFA/SCF DF62-EP30PCFA/PCF
Press Body	CM-105C	CL0901-0001-0-00	-
Hand Tool	HT801/DF62-22(10) (Note 3)	CL0550-0401-9-10	DF62-22SCA/SC DF62-EP22PCA/PC
	HT801/DF62-2428(10) (Note 4)	CL0550-0400-6-10	DF62-2428SCA/SC DF62-EP2428PCA/PC
	HT801/DF62-30(10) (Note5)	CL0550-0402-1-10	DF62-30SCA/SC DF62-EP30PCA/PC
Extraction Tool	DF62/RE-MD	CL0902-4645-4-00	DF62-##SCFA/SCF/SCA/SC DF62-EP##PCFA/PCF/PCA/PC

Note 1 : Issues with non-Hirose specified tools are outside the scope of warranty.

Note 2 : Please conduct crimping work according to the "Crimping Quality Standard" (ETAD-H0642,ETAD-H0643)" and "Crimping Condition Table".

Note 3 : The compatible wire is limited to UL1061 (22 AWG).

Note 4 : The compatible wire is limited to UL1007 (24 to 28 AWG).

Note 5 : The compatible wire is limited to UL1061 (30 AWG).

Note 6 : If you do not use tools specified by our company,

please contact your our company sales representative if you would like to request dies drawing.

Crimping

■ Items Required Prior to Starting

The work-related documents listed below are required before starting harness assembly.

(The ● mark indicates a required document.)

When the documents shown below are not available, ask a Hirose sales personnel to provide them.

Document Title	Description	Automatic Crimping Machine	Hand Crimping Tool	Remarks
(1) Main unit of crimping machine instruction manual	Explanation of main press machine unit	●	-	Bundled with the purchase of the main press machine unit.
(2) Applicator Spare Parts Identification	Explanation for Applicator installation	●	-	Bundled with the purchase of applicator.
(3) Crimp Conditions	Standard values of : Crimp height Tensile strength	●	-	
(4) Crimp Quality Standards	Various standards for crimping conditions	●	-	
(5) Operating Instructions for Hand Tool	Inspection items of : Crimp height Tensile strength and others	-	●	Bundled with the purchase of hand tool.
(6) Harness Procedure Manual DF62 Series : ETAD-H0593	Harness procedure	●	●	Ask a HRS sales representative.

■ Tools

The tools specified by Hirose should be used for crimping work.

- Crimping work by tools other than those specified must not be done because it may result in contact failure, disconnection of cable, etc.
- The operating instructions manual is available for the crimping machine and the applicator. Be sure to carefully read the operating instructions manual before implementing the work.

■ Applicable Electric Wires

When using a wire other than the applicable wires please contact a Hirose representative.

[Precautions]

- Electric wires that are suitable for crimping connectors are tin-plated stranded soft copper wire.
- Avoid crimping solid wires, wires with polyester threads or tin-coated wires.
- Avoid crimping two electric wires together.
- The crimp height setting value (Note) may vary between tin-plated and gold-plated contacts even if the same electric wires are used.
- The crimp height setting value (Note) may vary depending on the difference in the core wire configuration even if the computed cross-sectional area is the same.

Note : The crimp height is an important item that determines crimping quality. We execute crimping tests for each electric wire to ensure the optimal value for the crimp height with high precision, thereby ensuring optimal setup values.

Precautions

1.Cleaning Conditions	Please refer to the "Wire-to-Board Connector Guide (ETAD-H1023-00)". Cleaning with IPA is allowed. (Other cleaning agents are not recommended due to the fact that it may change the push/pull feeling. Please contact us when you use other cleaning agents.)
2.Important Notes	<ol style="list-style-type: none"> 1. Caution is required for mating and un-mating the connector without it being mounting on a PCB. Doing so can damage or deform the contacts. 2. During hand soldering, do not apply excess amounts of flux which can migrate onto the connector. 3. This product may have a slight differences in color depending on the production lot. This difference does not have any influence on the performance.
3.Handling Instructions	<p>Please refer to the materials listed below when handling this product.</p> <ul style="list-style-type: none"> ■ Crimping quality control statement of standards : ETAD-H0642-00, ETAD-H0643-00 ■ Harness procedure manual : ETAD-H0593-00 ■ Insertion/extraction manual : ETAD-H0599-00 ■ User Guide for Wire-to-Board Connector : ETAD-H1023-00

While Taking into Consideration

Specifications mentioned in this catalog are reference values.

When considering to order or use this product, please confirm the Drawing and Product Specifications sheets.

Use an appropriate cable when using the connector in combination with cables.

If considering usage of a non-specified cable, please contact your sales representative.

If assembly process is done by jigs & tools which are not identified by Hirose, assurance will not be given.

If considering usage for below mentioned applications, please contact your sales representative.

In cases where the application will demand a high level of reliability, such as automotive, medical instruments, public infrastructure, aerospace/ defense etc. Hirose must review before assurance of reliability can be given.