

Linear IC Converter

CMOS

A/D Converter

(With 4-channel Input at 12-bit Resolution)

MB88101A

■ DESCRIPTION

The MB88101A is an analog-to-digital converter that converts its analog input to a 12-bit digital value and outputs it as serial data.

The MB88101A employs a successive approximation method for A/D conversion.

The MB88101A has four input channels selectable for analog input under control of the dedicated external pins.

The MB88101A can be switched to a mode for continuous A/D conversion, in which it outputs serial data from the MSB or LSB selectable depending on the mode setting.

■ FEATURES

- 4-channel analog input
- One analog input channel selectable for conversion by external control
- CR-type successive approximation system with a sample-and-hole circuit
- 12-bit resolution
- Serial output of 12-bit digital data
- Capable of continuous conversion (continuous conversion mode)
- MSB or LSB selectable for serial output
- CMOS process
- Package options of 16-pin DIP, 16-pin SSOP, and 16-pin SOP available

■ PACKAGES

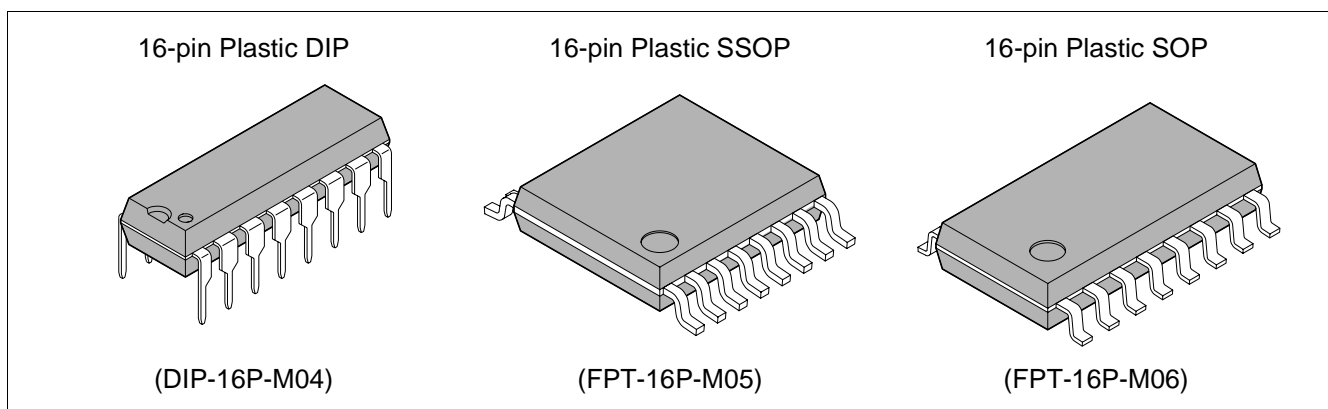

MB88101A

■ PIN ASSIGNMENT

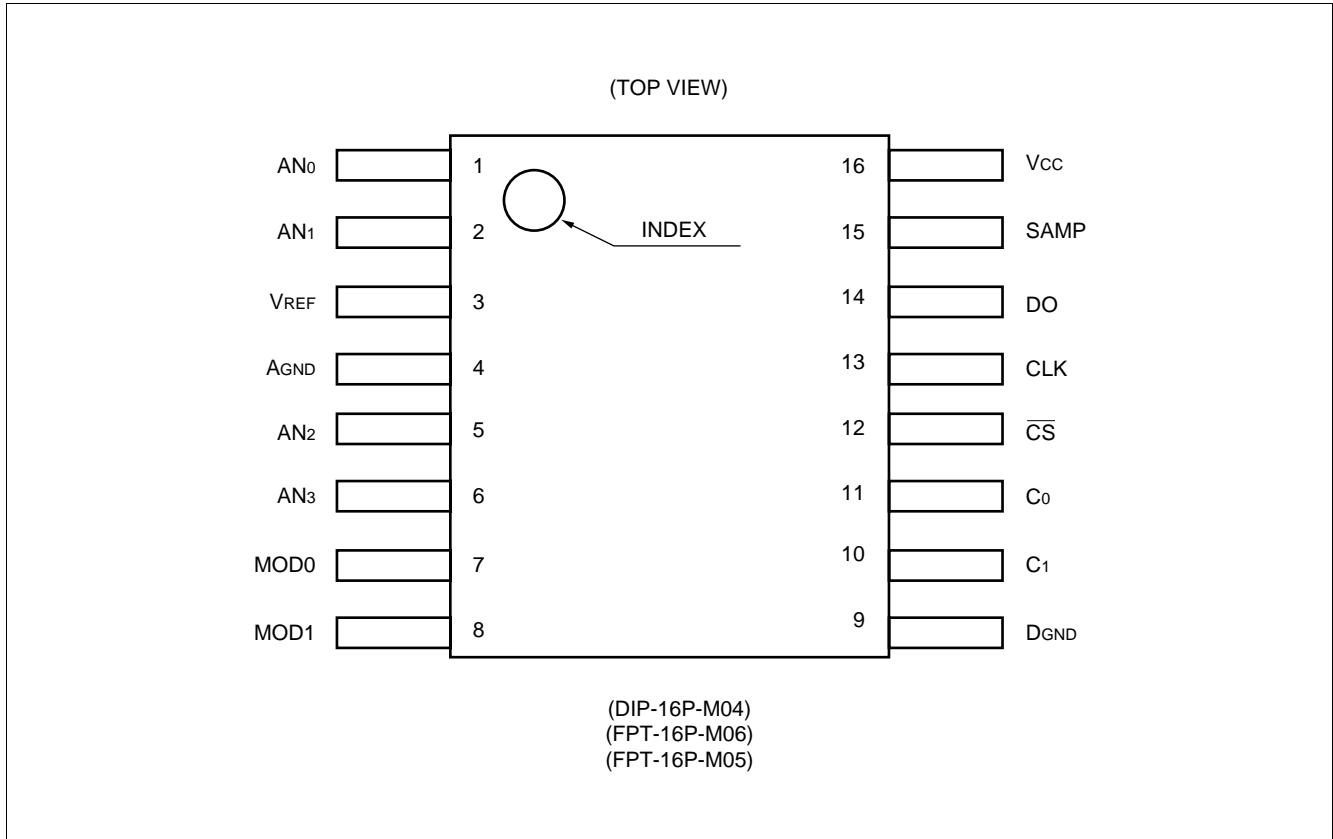

■ PIN DESCRIPTION

Pin no.	Symbol	I/O	Descriptions
1 2 5 6	AN ₀ AN ₁ AN ₂ AN ₃	I	Analog input pins. One of these channels can be selected depending on the C ₀ and C ₁ settings.
14	DO	O	This pin outputs the result of A/D conversion. The result is 12-bit serial data output in synchronization with the rise of CLK.
13	CLK	I	Clock input pin for A/D conversion
12	\overline{CS}	I	Chip select signal input pin. Setting the signal level to "L" after turning the power on starts A/D conversion; setting it to "H" stops A/D conversion. When this pin is "H", the DO and SAMP pins are "Hi-Z".
11 10	C ₀ C ₁	I	Input pins for selecting the analog input channels from among pins AN ₀ to AN ₃ . See Table 1 for the correspondence between the pin settings and the channels selected. To switch the channel in mode 2 or 3, set these pins before the SAMP pin goes "H".
7 8	MOD0 MOD1	I	Conversion mode setting pins. For the correspondence between the pin settings and the modes selected, see Table 2 and "■ FUNCTIONAL DESCRIPTION."
15	SAMP	O	This pin becomes active in prior to data output. Serial data is output from the DO pin five clock cycles after the signal level at this pin goes "L" after "H" for one clock cycle.
3	V _{REF}	—	Reference voltage input pin
4	A _{GND}	—	Analog circuit ground pin
9	D _{GND}	—	Digital circuit ground pin
16	V _{CC}	—	Power supply pin

Hi-Z : High-Z

• Channel selection

Table 1 Pin Settings and Channel Selection

C ₁	C ₀	Channel
L	L	AN ₀
L	H	AN ₁
H	L	AN ₂
H	H	AN ₃

• Mode selection

Table 2 Pin Settings and Mode Selection

MOD 0	MOD1	Mode
L	L	Mode 1
L	H	Mode 2
H	L	(Disabled)
H	H	Mode 3

MB88101A

■ BLOCK DIAGRAM

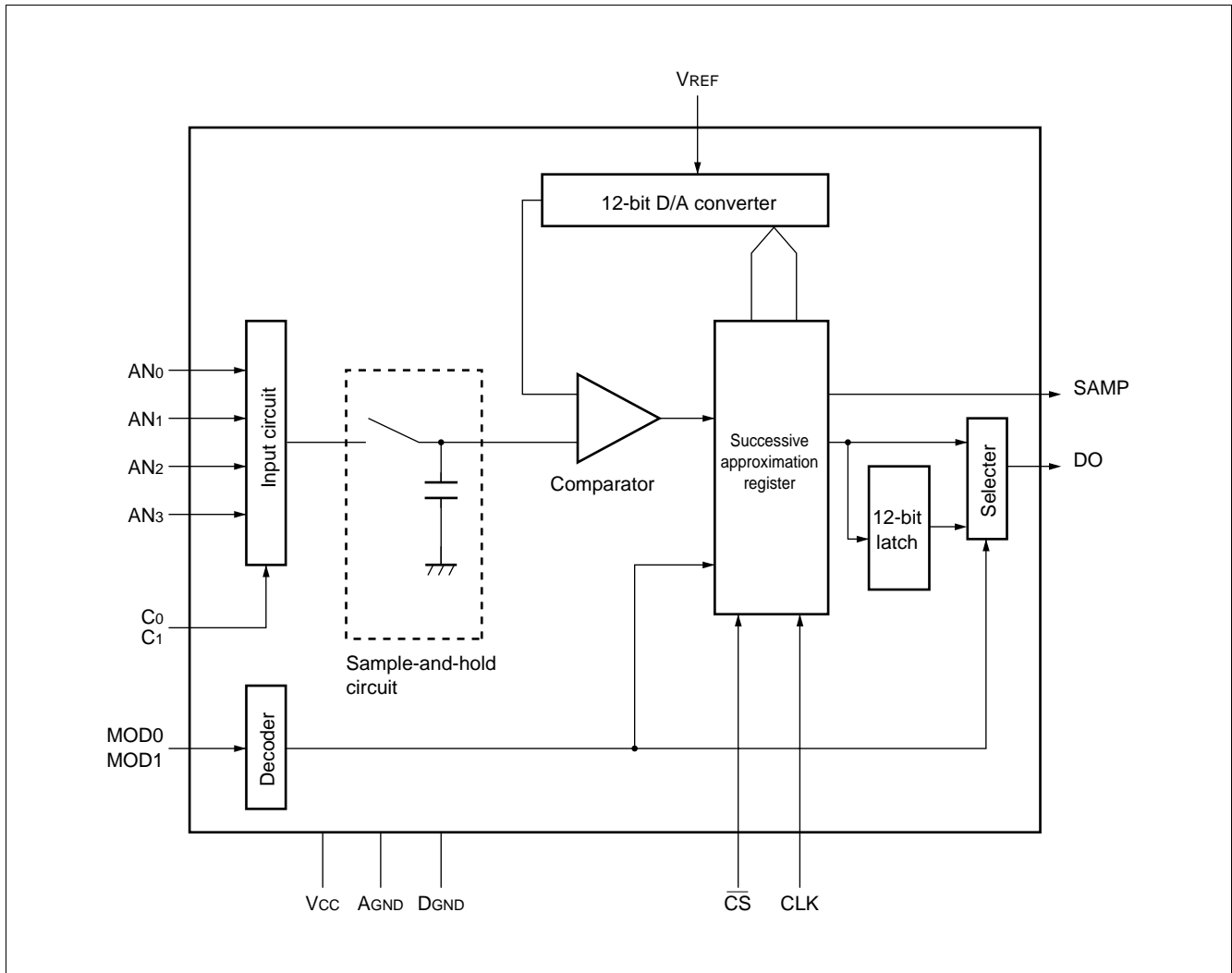

FUNCTIONAL DESCRIPTION

1. Mode 1

This mode sets the DO pin to “L” and stops conversion upon completion of conversion of 12 bits. To restart conversion, set \overline{CS} to “H” once then to “L”. In this mode, converted data is output from the MSB.

• **Timing diagram**

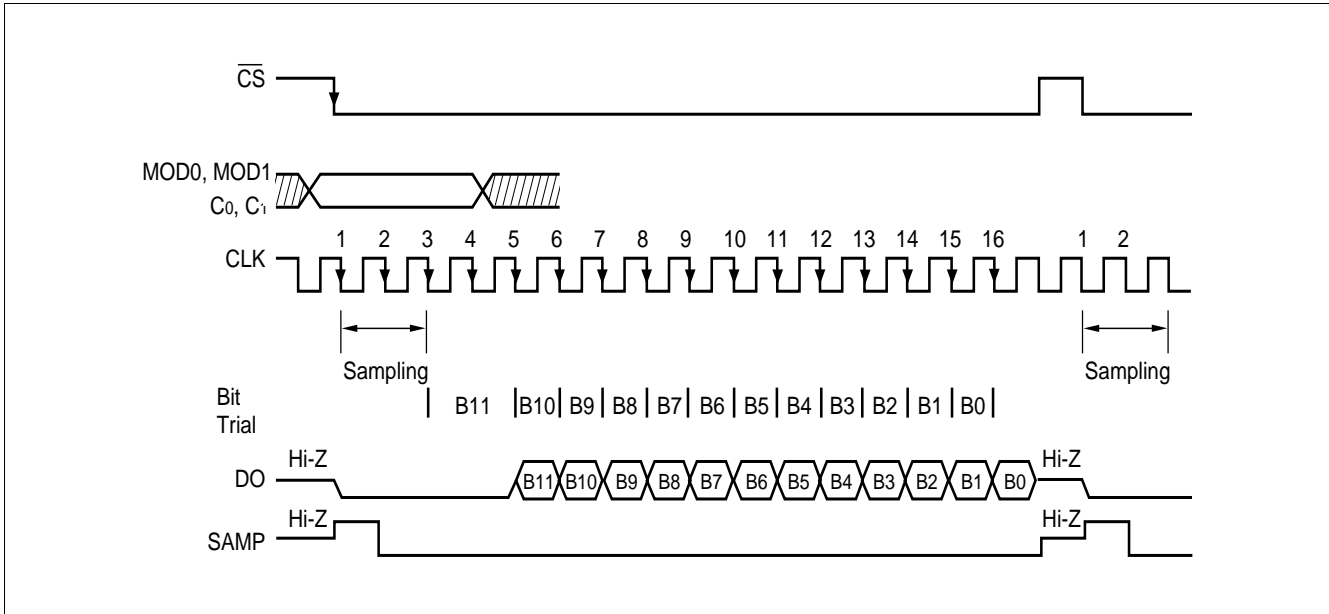

2. Mode 2

This mode continues conversion until \overline{CS} becomes “H” after it becomes “L”. Converted data is output from the LSB, with the first piece of converted data output 20 clock cycles after \overline{CS} becomes “L”. Changing the channel select pin settings before starting sampling of one analog input allows another to be converted.

• **Timing diagram**

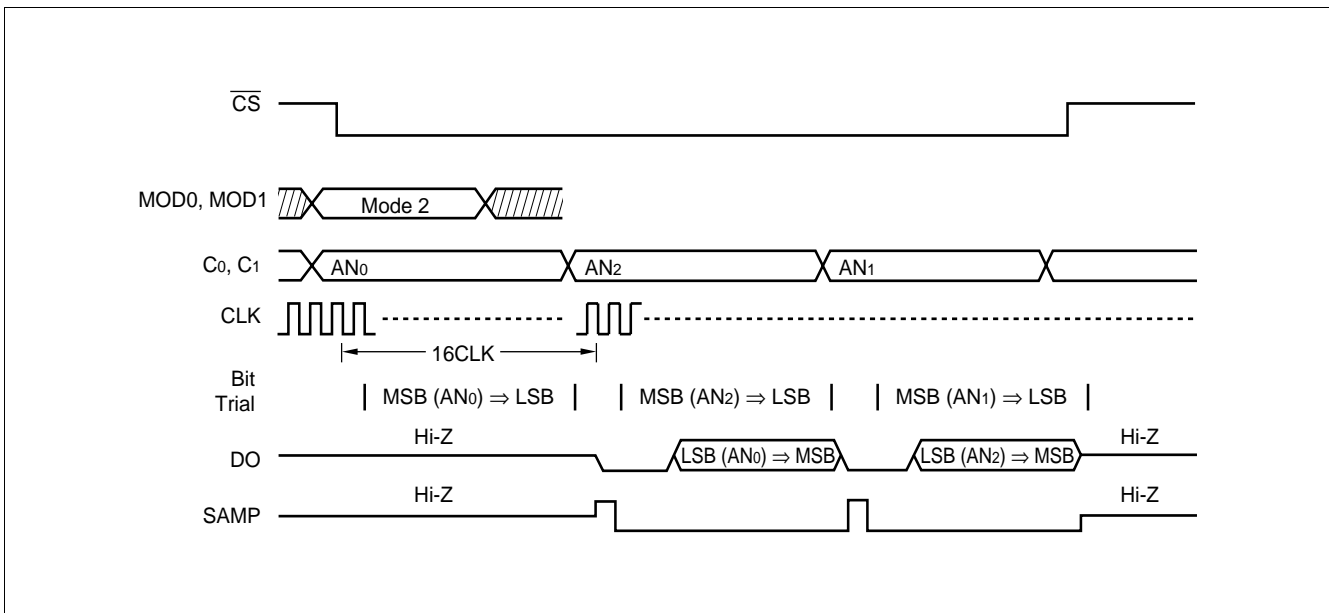

MB88101A

3. Mode 3

This mode continues conversion until \overline{CS} becomes "H" after it becomes "L". Converted data is output from the MSB. Changing the channel select pin settings before starting sampling of one analog input allows another to be converted.

- Timing diagram

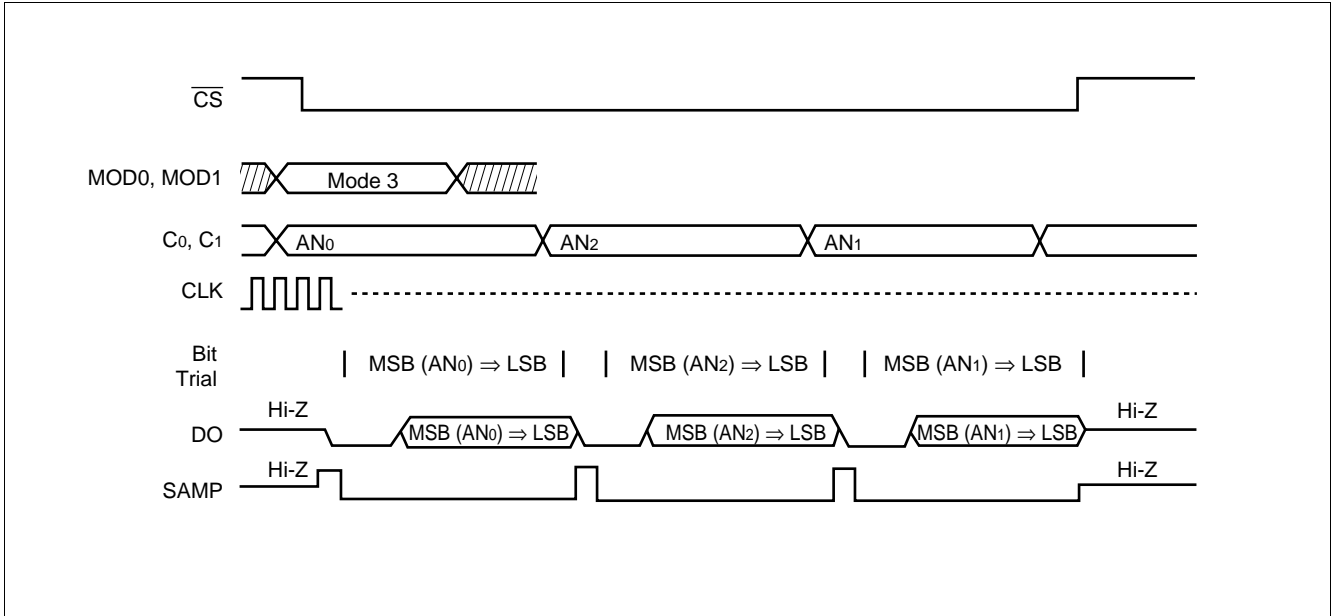

■ ABSOLUTE MAXIMUM RATINGS

Parameter	Symbol	Conditions	Rating		Unit
			Min	Max	
Power supply voltage	V _{CC}	Based on GND (T _a = +25°C)	-0.3	+7.0	V
	V _{REF}		-0.3*	+7.0*	V
Input voltage	V _{IN}		-0.3	V _{CC} + 0.3	V
Output voltage	V _{OUT}		-0.3	V _{CC} + 0.3	V
Power consumption	P _D	—	—	150	mW
Operating temperature	T _a	—	-40	+85	°C
Storage temperature	T _{stg}	—	-55	+150	°C

* : V_{CC} ≥ V_{REF}

WARNING: Semiconductor devices can be permanently damaged by application of stress (voltage, current, temperature, etc.) in excess of absolute maximum ratings. Do not exceed these ratings.

■ RECOMMENDED OPERATING CONDITIONS

Parameter	Symbol	Value			Unit
		Min	Typ	Max	
Power supply voltage	V _{CC}	3.3	—	5.5	V
	GND	—	0	—	V
Operation temperature	T _a	-40	—	+85	°C

WARNING: The recommended operating conditions are required in order to ensure the normal operation of the semiconductor device. All of the device's electrical characteristics are warranted when the device is operated within these ranges.

Always use semiconductor devices within their recommended operating condition ranges. Operation outside these ranges may adversely affect reliability and could result in device failure.

No warranty is made with respect to uses, operating conditions, or combinations not represented on the data sheet. Users considering application outside the listed conditions are advised to contact their representatives beforehand.

MB88101A

■ ELECTRICAL CHARACTERISTIC

1. DC Characteristics

(1) Digital section

($V_{CC} = 3.3\text{ V to }5.5\text{ V}$, $D_{GND} = 0\text{ V}$, $T_a = -40^\circ\text{C to }+85^\circ\text{C}$)

Parameter	Symbol	Pin name	Conditions	Value			Unit
				Min	Typ	Max	
Power supply voltage	V_{CC}	V_{CC}	—	3.3	5.0	5.5	V
Power supply current	I_{CC}		Operation at CLK = 166kHz (with no load)	—	0.8	2.0	mA
Input leakage current	I_{ILK}	MOD0, MOD1 CLK CS C ₀ C ₁	$V_{IN} = 0\text{ to }V_{CC}$	-10	—	10	μA
Low-level input voltage	V_{IL}		—	$V_{SS} - 0.3$	—	$0.2 V_{CC}$	V
High-level input voltage	V_{IH}		—	$0.8 V_{CC}$	—	$V_{CC} + 0.3$	V
High-impedance output leakage current	I_{OLZ}	DO SAMP	$V_{IN} = 0\text{ to }V_{CC}$	-10	—	10	μA
Low-level output voltage	V_{OL}		$I_{OL} = 2.5\text{ mA}$	—	—	0.4	V
High-level output voltage	V_{OH}		$I_{OH} = -400\ \mu\text{A}$	$V_{CC} - 0.4$	—	—	V

(2) Analog section

($V_{REF}, V_{CC} = 3.3\text{ V to }5.5\text{ V}$ ($V_{CC} \geq V_{REF}$), $A_{GND} = 0\text{ V}$, $T_a = -40^\circ\text{C to }+85^\circ\text{C}$)

Parameter	Symbol	Pin name	Value			Unit
			Min	Typ	Max	
Resolution	—	AN ₀ to AN ₃	—	12	—	bit
Linearity error	—		-4.0	—	2.0	LSB
Differential linearity error	—		-1.0	—	3.0	LSB
Conversion time	—	—	—	16	—	CLK
Consumption current	I_{REF}	V_{REF}	—	100	300	μA
Analog reference voltage	—		3.3	5.0	V_{CC}	V
Analog input voltage	—	AN ₀ to AN ₃	0	—	V_{REF}	V

(3) Definitions of A/D converter terms

- Resolution
Analog transition identifiable by the A/D converter
- Linearity error
Deviation of the straight line drawn between the zero transition point (0000 0000 0000 ↔ 0000 0000 0001) and the full-scale transition point (1111 1111 1110 ↔ 1111 1111 1111) of the device from actual conversion characteristics
- Differential linearity error
Deviation from the ideal input voltage required to shift output code by one LSB

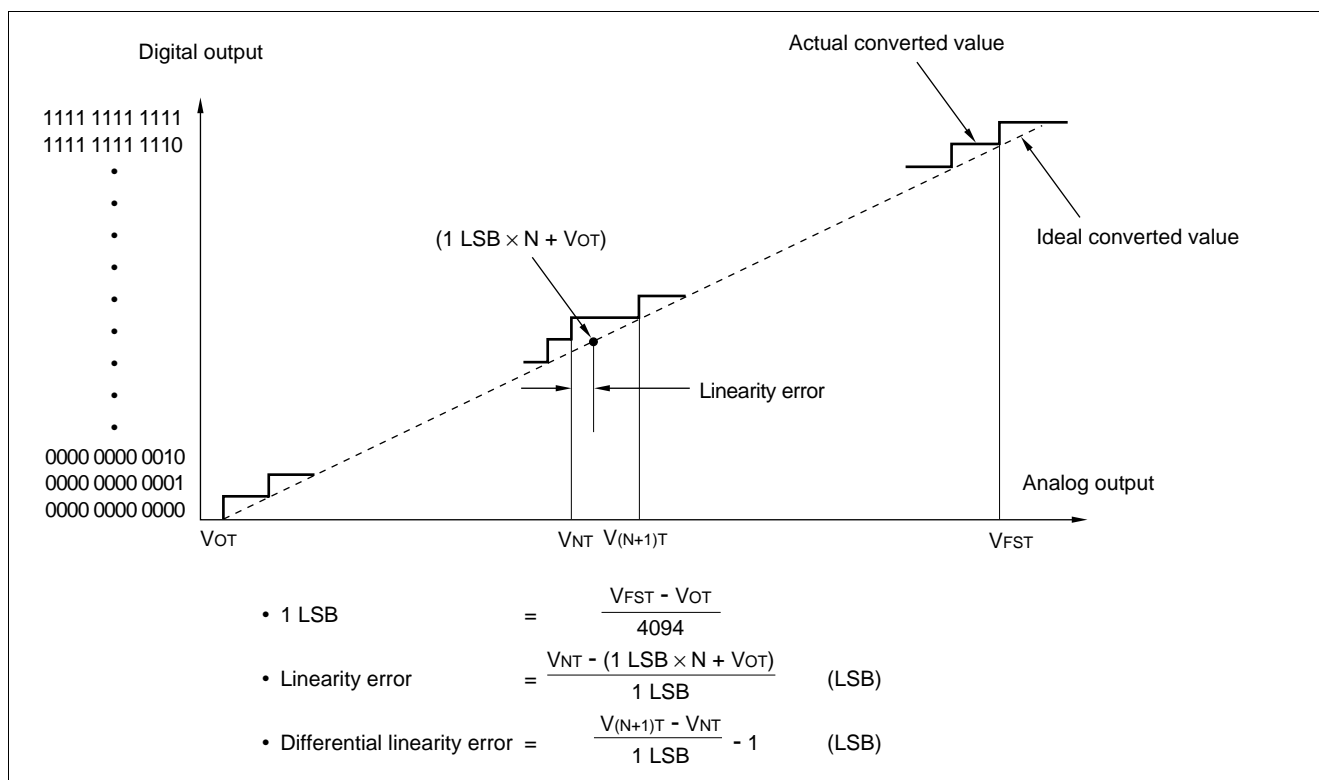

• Analog input equivalent circuit

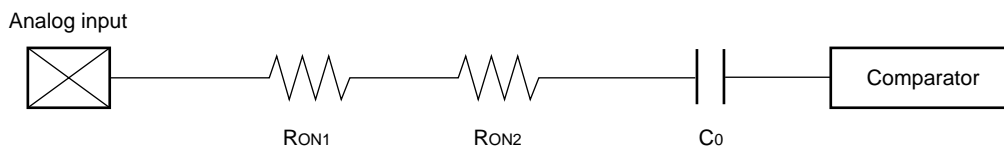

- RON1 = About 1.5 kΩ
- RON2 = About 1.5 kΩ
- C0 = About 60 pF

Note: The above values are reference values.

- Notes:
- The tolerance of output impedance of an external circuit connected to this A/D converter has an effect on conversion time (CLK frequency). See "■ TYPICAL CHARACTERISTICS".
 - If the output impedance of the external input is too high, the analog voltage sampling time may be short.
 - When turning the device on, turn the power supply for the digital system first before turning VREF on.

MB88101A

2. AC Characteristics

(V_{REF} , $V_{CC} = 3.3\text{ V to }+5.5\text{ V}$ ($V_{CC} \geq V_{REF}$), $A_{GND} = 0\text{ V}$, $T_a = -40^\circ\text{C to }+85^\circ\text{C}$)

Parameter	Symbol	Conditions	Value		Unit
			Min	Max	
Clock cycle time	t_{CLK}	$V_{CC} = 5\text{ V} \pm 10\%$ *1	1.0	30.0	μS
		—	6.0	30.0	μS
Low-level clock pulse width	t_{CKL}	—	2.8	14.8	μS
High-level clock pulse width	t_{CKH}	—	2.8	14.8	μS
Clock rise time	t_{Cr}	—	—	0.2	μS
Clock fall time	t_{Cf}				
$\overline{\text{CS}}$ setup time	t_{CSS}	—	$t_{CKL} + 0.4$	—	μS
$\overline{\text{CS}}$ hold time	t_{CSH}	—	1.0	—	μS
$\overline{\text{CS}}$ release time	t_{CSR}	—	1.0	—	CLK
Channel setup time	t_{CHS}	—	0	—	μS
Channel hold time	t_{CHH}	—	1.0	—	CLK
Data output delay time	t_{DO}	*2	—	0.5	μS
MOD setup time	t_{MOS}	—	0.2	—	μS
MOD hold time	t_{MOH}	—	0.1	—	μS
Data active delay time	t_{DVE}	—	—	0.5	μS
Data float delay time	t_{DZE}	—	—	0.5	μS
SAMP active delay time	t_{SVE}	—	—	0.5	μS
SAMP float delay time	t_{SZE}	—	—	0.5	μS
SAMP high-level output delay time	t_{SHD}	*2	—	0.5	μS
SAMP low-level output delay time	t_{SLD}	*2	—	0.5	μS

*1: Depending on the output impedance of the external circuit connected to the analog input pin

*2: See “• AC test circuit.”

• AC test circuit

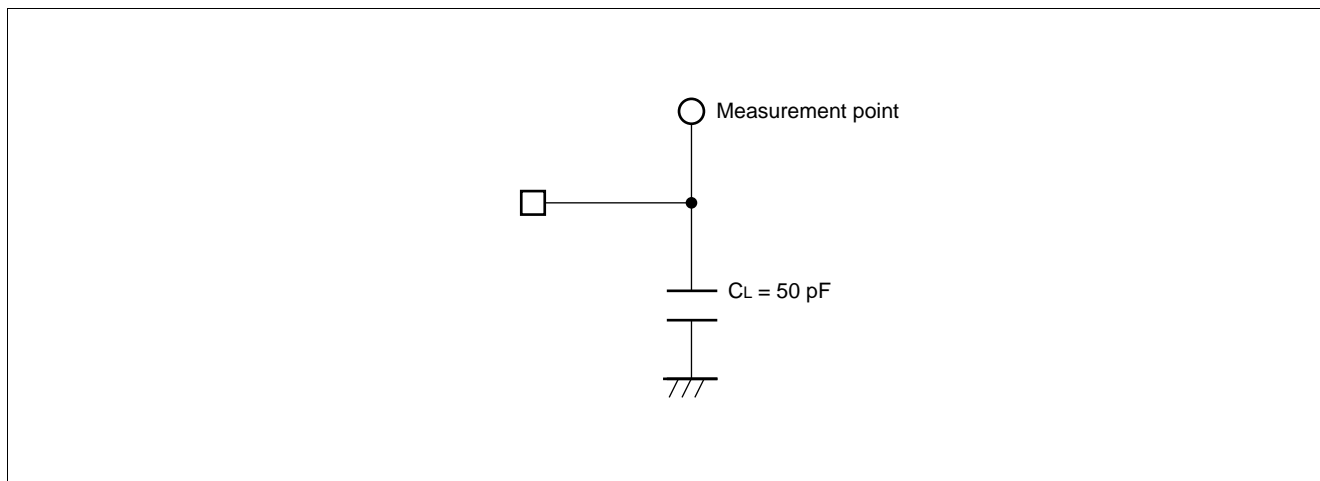

■ TIMING DIAGRAM

(1) Input clock timing

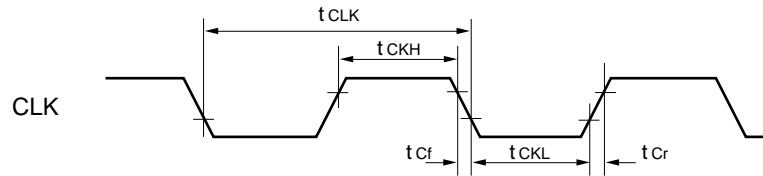

Evaluation levels are 80% and 20% of the V_{CC} .

(2) A/D startup timing

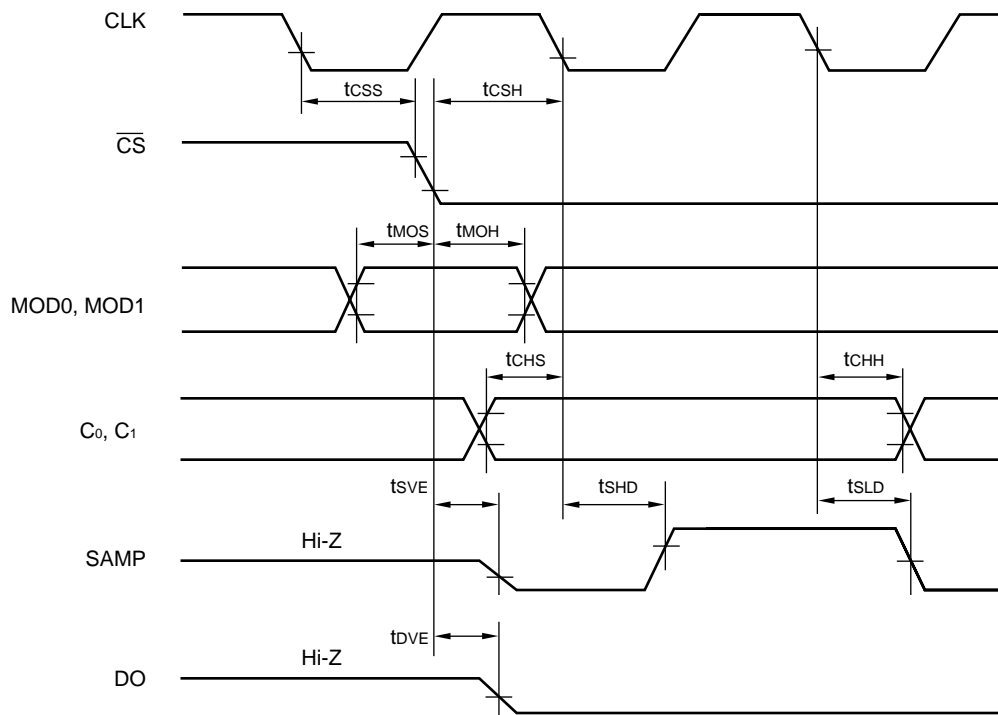

MB88101A

(3) Data output delay time and A/D stop timing

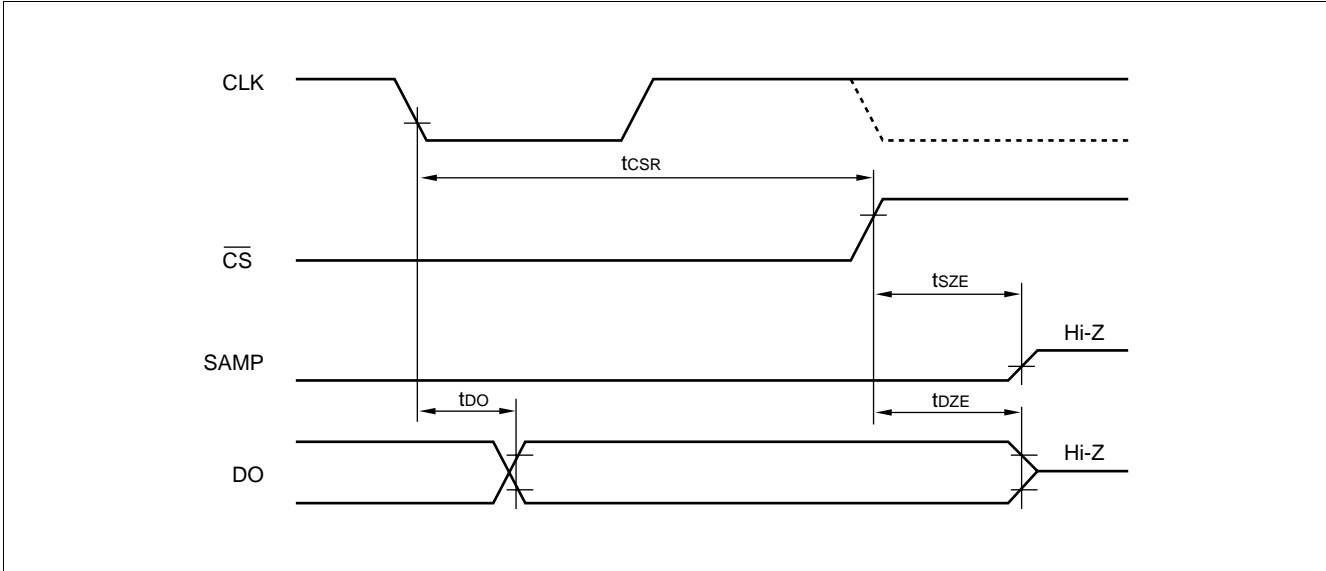

■ TYPICAL CHARACTERISTICS

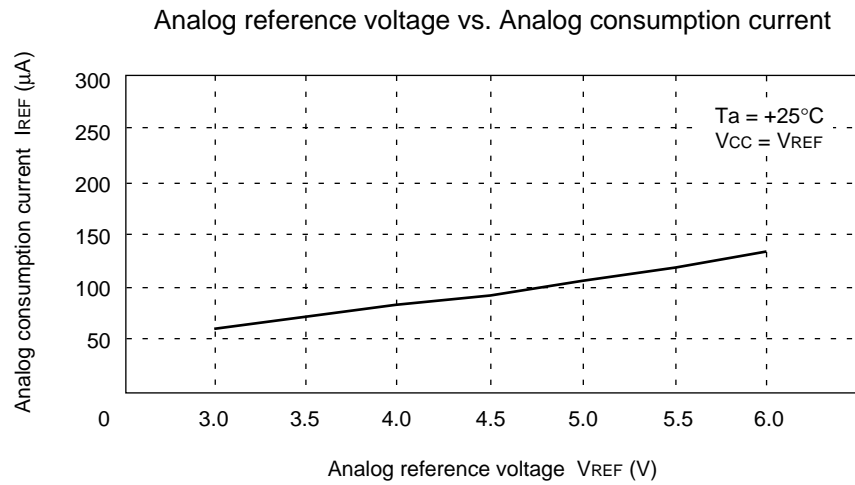
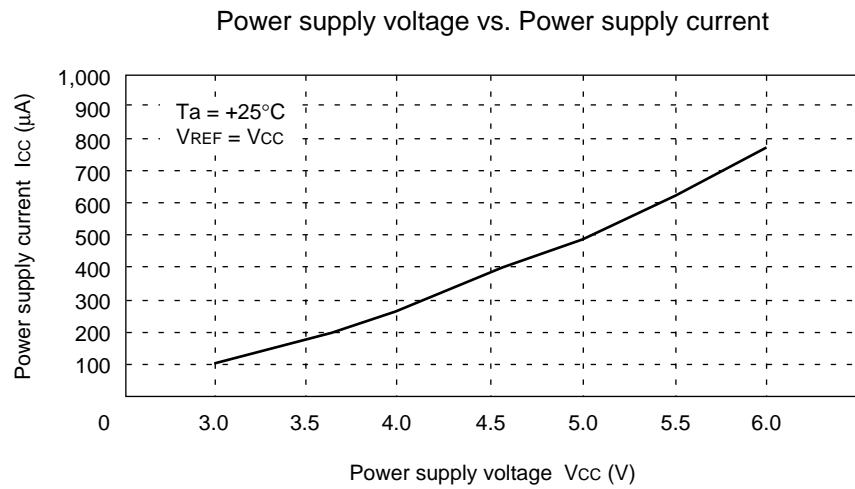

(Continued)

MB88101A

(Continued)

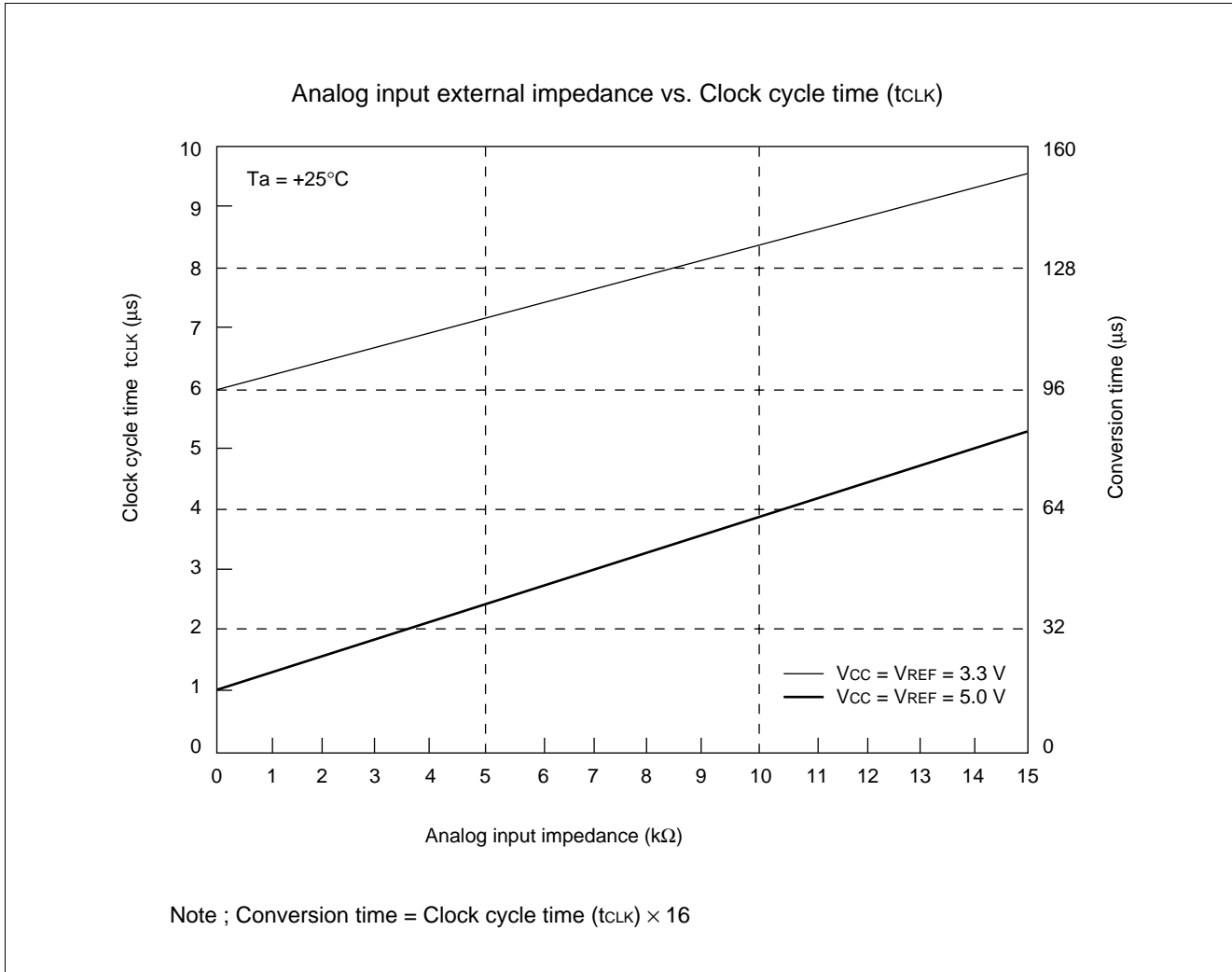

■ ORDERING INFORMATION

Part number	Package	Remarks
MB88101AP	16-pin Plastic DIP (DIP-16P-M04)	
MB88101APFV	16-pin Plastic SSOP (FPT-16P-M05)	
MB88101APF	16-pin Plastic SOP (FPT-16P-M06)	

MB88101A

■ PACKAGE DIMENSIONS

16-pin Plastic DIP
(DIP-16P-M04)

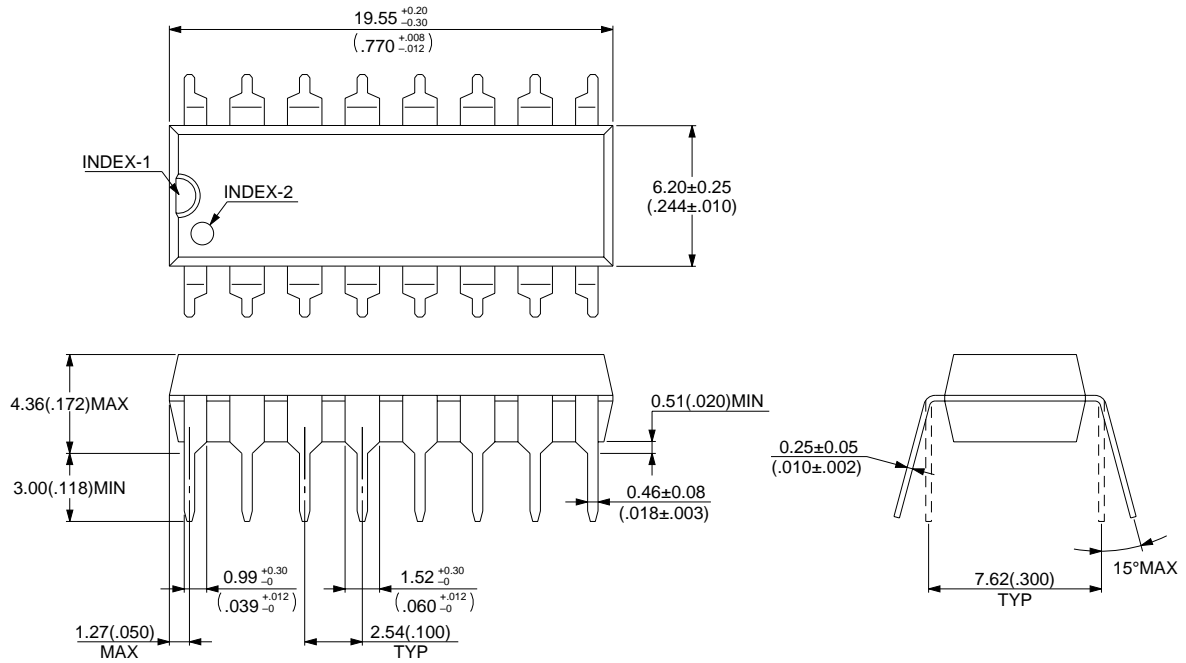

© 1994 FUJITSU LIMITED D16033S-2C-3

Dimensions in mm (inches) .

Note : The values in parentheses are reference values.

(Continued)

16-pin Plastic SSOP (FPT-16P-M05)

- Note 1) *1 : Resin protrusion. (Each side : +0.15 (.006) Max).
 Note 2) *2 : These dimensions do not include resin protrusion.
 Note 3) Pins width and pins thickness include plating thickness.
 Note 4) Pins width do not include tie bar cutting remainder.

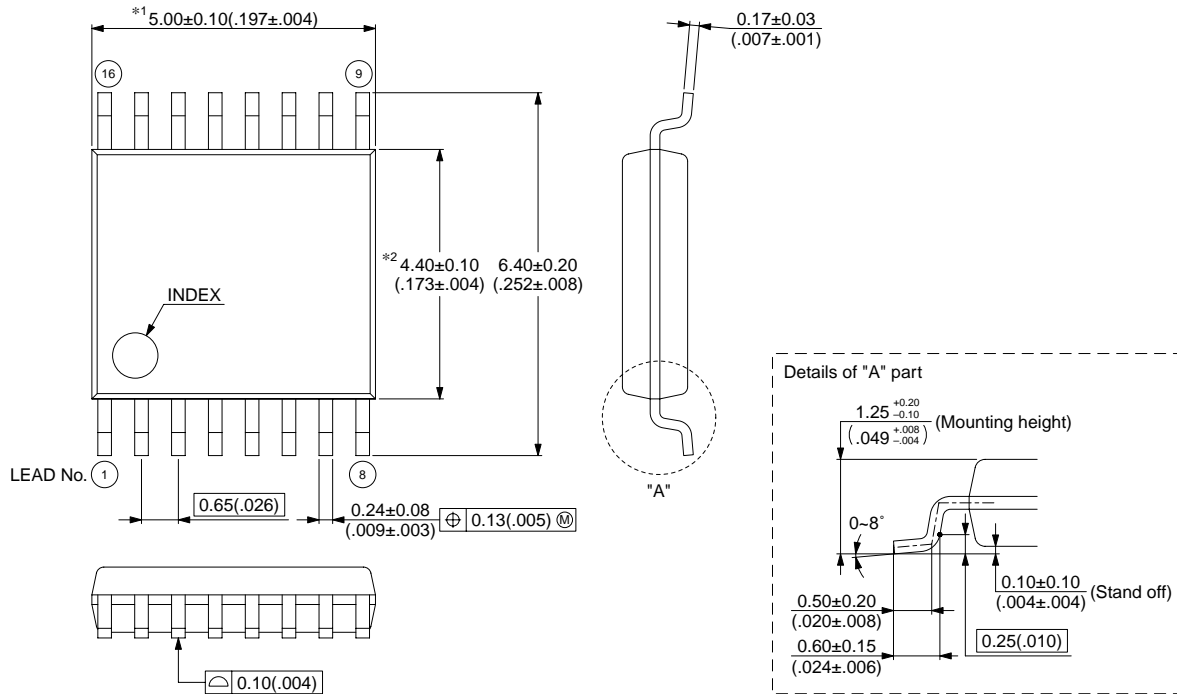

© 2003 FUJITSU LIMITED F16013S-c-4-6

Dimensions in mm (inches) .

Note : The values in parentheses are reference values.

(Continued)

MB88101A

(Continued)

16-pin Plastic SOP
(FPT-16P-M06)

- Note 1) *1 : These dimensions include resin protrusion.
- Note 2) *2 : These dimensions do not include resin protrusion.
- Note 3) Pins width and pins thickness include plating thickness.
- Note 4) Pins width do not include tie bar cutting remainder.

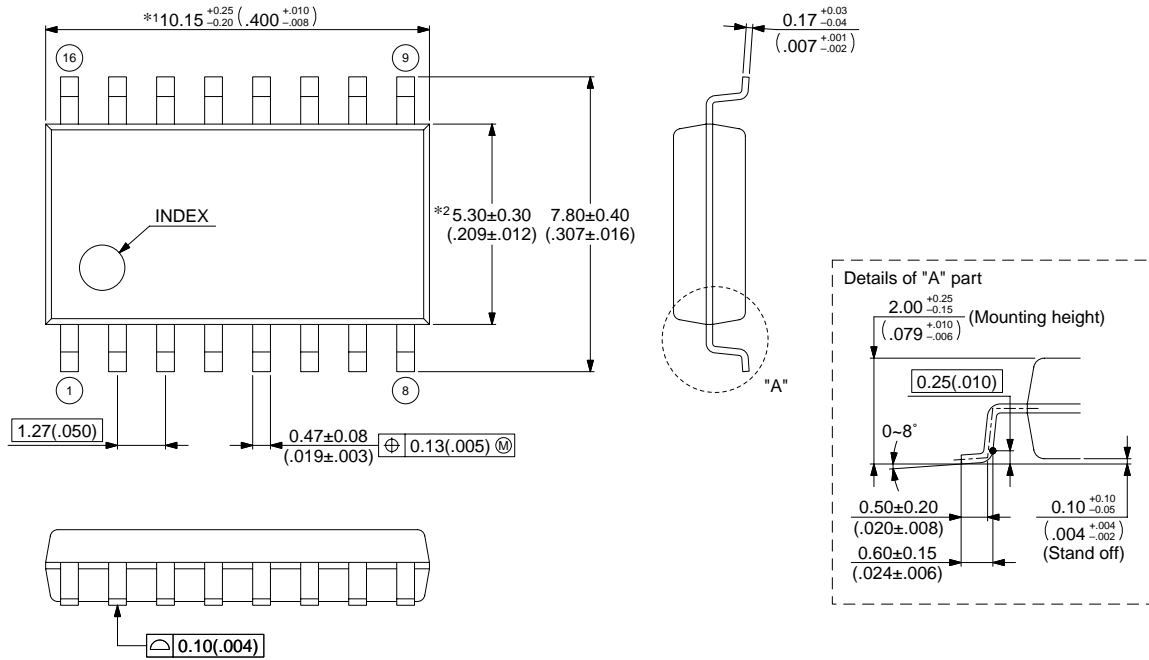

© 2002 FUJITSU LIMITED F16015S-c-4-7

Dimensions in mm (inches) .

Note : The values in parentheses are reference values.

MEMO



FUJITSU MICROELECTRONICS LIMITED

Shinjuku Dai-Ichi Seimei Bldg. 7-1, Nishishinjuku 2-chome, Shinjuku-ku,
Tokyo 163-0722, Japan Tel: +81-3-5322-3347 Fax: +81-3-5322-3387
<http://jp.fujitsu.com/fml/en/>

For further information please contact:

North and South America

FUJITSU MICROELECTRONICS AMERICA, INC.
1250 E. Arques Avenue, M/S 333
Sunnyvale, CA 94085-5401, U.S.A.
Tel: +1-408-737-5600 Fax: +1-408-737-5999
<http://www.fma.fujitsu.com/>

Europe

FUJITSU MICROELECTRONICS EUROPE GmbH
Pittlerstrasse 47, 63225 Langen,
Germany
Tel: +49-6103-690-0 Fax: +49-6103-690-122
<http://emea.fujitsu.com/microelectronics/>

Korea

FUJITSU MICROELECTRONICS KOREA LTD.
206 KOSMO TOWER, 1002 Daechi-Dong,
Kangnam-Gu, Seoul 135-280
Korea
Tel: +82-2-3484-7100 Fax: +82-2-3484-7111
<http://www.fmk.fujitsu.com/>

Asia Pacific

FUJITSU MICROELECTRONICS ASIA PTE LTD.
151 Lorong Chuan, #05-08 New Tech Park,
Singapore 556741
Tel: +65-6281-0770 Fax: +65-6281-0220
<http://www.fujitsu.com/sg/services/micro/semiconductor/>

FUJITSU MICROELECTRONICS SHANGHAI CO., LTD.
Rm.3102, Bund Center, No.222 Yan An Road(E),
Shanghai 200002, China
Tel: +86-21-6335-1560 Fax: +86-21-6335-1605
<http://cn.fujitsu.com/fmc/>

FUJITSU MICROELECTRONICS PACIFIC ASIA LTD.
10/F., World Commerce Centre, 11 Canton Road
Tsimshatsui, Kowloon
Hong Kong
Tel: +852-2377-0226 Fax: +852-2376-3269
<http://cn.fujitsu.com/fmc/tw>

All Rights Reserved.

The contents of this document are subject to change without notice.

Customers are advised to consult with sales representatives before ordering.

The information, such as descriptions of function and application circuit examples, in this document are presented solely for the purpose of reference to show examples of operations and uses of FUJITSU MICROELECTRONICS device; FUJITSU MICROELECTRONICS does not warrant proper operation of the device with respect to use based on such information. When you develop equipment incorporating the device based on such information, you must assume any responsibility arising out of such use of the information.

FUJITSU MICROELECTRONICS assumes no liability for any damages whatsoever arising out of the use of the information.

Any information in this document, including descriptions of function and schematic diagrams, shall not be construed as license of the use or exercise of any intellectual property right, such as patent right or copyright, or any other right of FUJITSU MICROELECTRONICS or any third party or does FUJITSU MICROELECTRONICS warrant non-infringement of any third-party's intellectual property right or other right by using such information. FUJITSU MICROELECTRONICS assumes no liability for any infringement of the intellectual property rights or other rights of third parties which would result from the use of information contained herein.

The products described in this document are designed, developed and manufactured as contemplated for general use, including without limitation, ordinary industrial use, general office use, personal use, and household use, but are not designed, developed and manufactured as contemplated (1) for use accompanying fatal risks or dangers that, unless extremely high safety is secured, could have a serious effect to the public, and could lead directly to death, personal injury, severe physical damage or other loss (i.e., nuclear reaction control in nuclear facility, aircraft flight control, air traffic control, mass transport control, medical life support system, missile launch control in weapon system), or (2) for use requiring extremely high reliability (i.e., submersible repeater and artificial satellite).

Please note that FUJITSU MICROELECTRONICS will not be liable against you and/or any third party for any claims or damages arising in connection with above-mentioned uses of the products.

Any semiconductor devices have an inherent chance of failure. You must protect against injury, damage or loss from such failures by incorporating safety design measures into your facility and equipment such as redundancy, fire protection, and prevention of over-current levels and other abnormal operating conditions.

Exportation/release of any products described in this document may require necessary procedures in accordance with the regulations of the Foreign Exchange and Foreign Trade Control Law of Japan and/or US export control laws.

The company names and brand names herein are the trademarks or registered trademarks of their respective owners.