



# DM74AS811 Quad 2-Input Exclusive-NOR Gate with Open-Collector Outputs

## General Description

This device contains four independent gates, each of which performs the logic exclusive-NOR function. The open-collector outputs require external pull-up resistors for proper logical operation.

## Pull-Up Resistor Equations

$$R_{MAX} = \frac{V_{CC}(Min) - V_{OH}}{N_1(I_{OH}) + N_2(I_{IH})}$$

$$R_{MIN} = \frac{V_{CC}(Max) - V_{OL}}{I_{OL} - N_3(I_{IL})}$$

Where:  $N_1(I_{OH})$  = total maximum output high current for all outputs tied to pull-up resistor

$N_2(I_{IH})$  = total maximum input high current for all inputs tied to pull-up resistor

$N_3(I_{IL})$  = total maximum input low current for all inputs tied to pull-up resistor

## Features

- Switching specifications at 50 pF
- Switching specifications guaranteed over full temperature and  $V_{CC}$  range
- Advanced oxide-isolated, ion-implanted Schottky TTL process
- Functionally and pin for pin compatible with advanced low power Schottky TTL counterpart
- Improved AC performance over advanced low power Schottky counterparts
- Open collector outputs for wired AND cascading
- PNP input design reduces input loading

## Connection Diagram

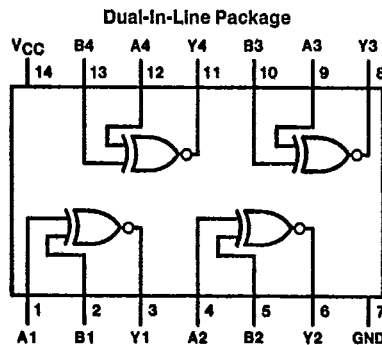

Order Number DM74ALS811N  
See NS Package Number N14A\*

TL/F/6725-1

## Function Table

$$\bar{Y} = A \oplus B$$

Inputs		Output
A	B	$\bar{Y}$
L	L	H
L	H	L
H	L	L
H	H	H

H = High Logic Level  
L = Low Logic Level

\*Contact your local NSC representative about surface mount (M) package availability.

T-43-15

**Absolute Maximum Ratings**

Supply Voltage	7V
Input Voltage	7V
Off State Output Voltage	7V
Operating Free Air Temperature Range	0°C to +70°C
Storage Temperature Range	-65°C to +150°C
Typical $\theta_{JA}$ N Package	74.5°C/W

Note: The "Absolute Maximum Ratings" are those values beyond which the safety of the device cannot be guaranteed. The device should not be operated at these limits. The parametric values defined in the "Electrical Characteristics" table are not guaranteed at the absolute maximum ratings. The "Recommended Operating Conditions" table will define the conditions for actual device operation.

**Recommended Operating Conditions**

Symbol	Parameter	Min	Nom	Max	Units
V <sub>CC</sub>	Supply Voltage	4.5	5	5.5	V
V <sub>IH</sub>	High Level Input Voltage	2			V
V <sub>IL</sub>	Low Level Input Voltage			0.8	V
V <sub>OH</sub>	High Level Output Voltage			5.5	V
I <sub>OL</sub>	Low Level Output Current			20	mA
T <sub>A</sub>	Free Air Operating Temperature	0		70	°C

**Electrical Characteristics** over recommended operating free air temperature range (unless otherwise noted)

Symbol	Parameter	Conditions	Min	Typ (Note 1)	Max	Units
V <sub>IK</sub>	Input Clamp Voltage	V <sub>CC</sub> = Min, I <sub>I</sub> = -18 mA			-1.2	V
I <sub>CEX</sub>	High Level Output Current Current	V <sub>CC</sub> = Min, V <sub>O</sub> = 5.5V V <sub>IL</sub> = Max, V <sub>IH</sub> = Min			100	μA
V <sub>OL</sub>	Low Level Output Voltage	V <sub>CC</sub> = Min, I <sub>OL</sub> = Max V <sub>IH</sub> = Min, V <sub>IL</sub> = Max		0.35	0.5	V
I <sub>I</sub>	Input Current @ Max Input Voltage	V <sub>CC</sub> = Max, V <sub>I</sub> = 7V			0.1	mA
I <sub>IH</sub>	High Level Input Current	V <sub>CC</sub> = Max, V <sub>I</sub> = 2.7V			20	μA
I <sub>CCH</sub>	Supply Current with Outputs High	V <sub>CC</sub> = Max (Note 3)		19.6	28	mA
I <sub>CCL</sub>	Supply Current with Outputs Low	V <sub>CC</sub> = Max (Note 2)		25	36	mA

Note 1: All typicals are at V<sub>CC</sub> = 5V, T<sub>A</sub> = 25°C.  
 Note 2: I<sub>CCL</sub> is measured with all outputs open, one input of each at 4.5V, and the other inputs grounded.  
 Note 3: I<sub>CCH</sub> is measured with all outputs open and all inputs at 4.5V.

**Switching Characteristics** over recommended operating free air temperature range (Note 4)

Symbol	Parameter	Conditions	Min	Max	Units
t <sub>PLH</sub>	Propagation Delay Time Low to High Level Output	Other Input Low V <sub>CC</sub> = 4.5V to 5.5V R <sub>L</sub> = 500Ω C <sub>L</sub> = 50 pF	5	45	ns
t <sub>PHL</sub>	Propagation Delay Time High to Low Level Output		1	8.5	ns
t <sub>PLH</sub>	Propagation Delay Time Low to High Level Output	Other Input High V <sub>CC</sub> = 4.5V to 5.5V R <sub>L</sub> = 500Ω C <sub>L</sub> = 50 pF	5	45	ns
t <sub>PHL</sub>	Propagation Delay Time High to Low Level Output		2	9	ns

Note 4: See Section 1 for test waveforms and output load.

