

## 2.4GHz CMOS SP3T ANTENNA SWITCH

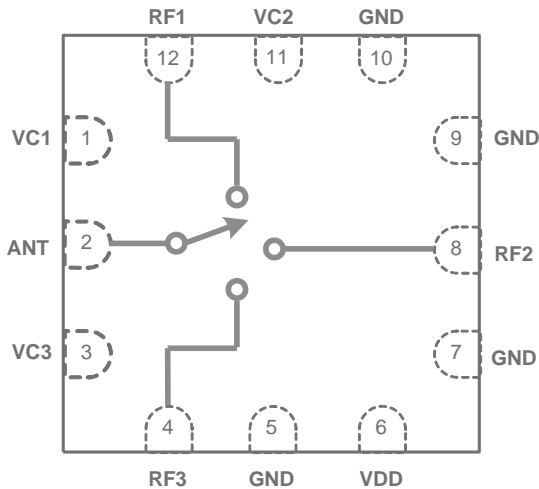

### PIN DESCRIPTION

### DESCRIPTION

RFX333 is a Single-Pole, Triple-Throw (SP3T) antenna switch developed in CMOS technology. The device is optimized for wireless applications requiring high linearity and low insertion loss, such as WLAN IEEE 802.11b/g/n and Bluetooth in the 2.4GHz frequency range.

The RFX333 has simple and low-voltage CMOS control logic, and requires minimal external components. All DC-blocking capacitors are integrated on-chip to minimize PCB footprint. RFX333 is assembled in a small 1.6mmx1.6mmx0.45mm 12-Lead Quad Flat No-Lead (QFN) package. The ultra-compact size and low profile makes the RFX333 an ideal RF switch solution for Mobile Handset and Smartphone platforms.

### APPLICATIONS

- ▶ IEEE 802.11b/g/n
- ▶ Bluetooth
- ▶ Handsets/Smartphones
- ▶ Mobile/Portable Devices
- ▶ Consumer Electronics
- ▶ Other 2.4GHz Radio Platforms

### FEATURES

- ▶ 2.4GHz SP3T Switch with On-Chip DC Blocking Capacitors on all RF Ports
- ▶ Fast Switching Time
- ▶ Compatible with Low Voltage (1.2V) CMOS Control Logic or levels up to VDD
- ▶ ESD Protection Circuitry on All Ports
- ▶ AC Coupled in all RF Ports
- ▶ Very Low DC Power Consumption
- ▶ Internal RF Decoupling on VDD Bias Pin
- ▶ Full On-chip Matching and Decoupling Circuitry
- ▶ Minimal External Components Required
- ▶ 50-Ohm Input / Output Matching
- ▶ 1.6mmx1.6mmx0.45mm Small Outline 12L-QFN Package with Exposed Ground Pad
- ▶ RoHS and REACH Compliant

Pin Number	Pin Name	Description
1	VC1	Switch Control 1

2	ANT	Antenna Port
3	VC3	Switch Control 3
4	RF3	RF Port 3
5, 7, 9, 10, 13	GND	Ground – Must Be Connected to Ground in the Application Circuit
6	VDD	DC Voltage Supply
8	RF2	RF Port 2
11	VC2	Switch Control 2
12	RF1	RF Port 1

**PIN-OUT DIAGRAM**

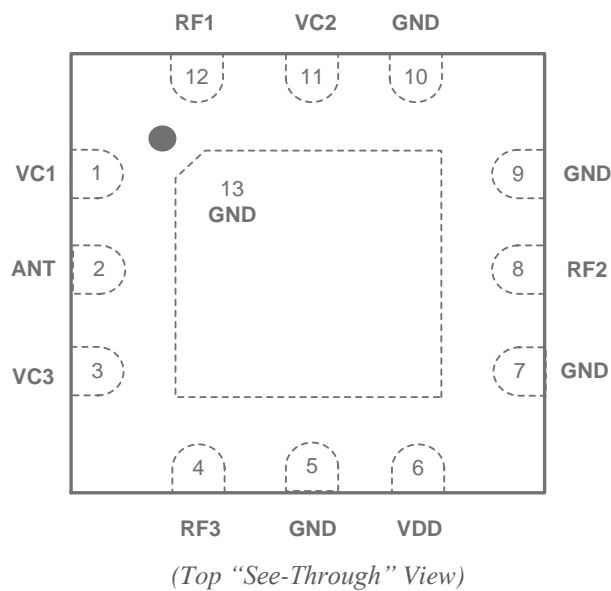

**ABSOLUTE MAXIMUM RATINGS**

Parameters	Min	Max	Units	Conditions
DC VDD Voltage Supply	3	5	V	All VDD Pins
DC Control Pin Voltage	0	3.6	V	All Control Pins
DC Current Consumption		1	uA	VDD Pin when Switch is active
RF Input Power		+30	dBm	All RF Ports
ANT RF Input Power		+30	dBm	ANT Port
Storage Ambient Temperature	-50	+125	°C	Appropriate care required according to JEDEC Standards
Operating Ambient Temperature	-40	+85	°C	All Operating Modes
ESD Voltage (HBM)	1000		V	Human Body Model

*Note: Sustained operation at or above the Absolute Maximum Ratings for any single or combinations of the above parameters may result in permanent damage to the device and is not recommended. All Maximum RF Input Power Ratings assume 50-Ohm terminal impedance.*

**GENERAL CHARACTERISTICS**

Parameters	Min	Typ	Max	Units	Conditions
Operating Frequency	2.4		2.5	GHz	
DC Voltage Supply ( <i>Note 1</i> )	3.0	3.6	4.8	V	
Control Voltage “High”	1.2		3.6	V	
Control Voltage “Low”		0	0.3	V	
Control Pin Current Consumption		1		μA	
DC Shutdown Current			1	μA	
Switching Time		150		nsec	
Input/Output Single-Ended Impedance		50		Ω	

*Note 1 – For normal operation of the RFX333, VDD must be continuously applied to VDD supply pin.*

**SWITCHES CHARACTERISTICS (VDD=3.6V, T<sub>A</sub>=+25 °C, UNLESS OTHERWISE SPECIFIED)**

Parameters	Min	Typ	Max	Units	Conditions
Operating Frequency Band	2.4		2.5	GHz	All RF Pins Terminated by 50 Ohms
Input P0.1dB		+29		dBm	CW
Isolation	25	30		dB	
Insertion Loss		0.6		dB	ANT Port to any RF Ports
Second Harmonic		-50		dBc	P <sub>OUT</sub> = +23dBm, CW
Third Harmonic		-55		dBc	P <sub>OUT</sub> = +23dBm, CW
Input Return Loss		-15		dB	At RF Pins
Output Return Loss		-15		dB	At ANT Pin
Quiescent Current		1		uA	
Load VSWR for Stability (CW, Fix Pin for P <sub>OUT</sub> = +29dBm with 50Ω Load)		6:1		N/A	All non-harmonically related spurs less than -43 dBm/Hz
Load VSWR for Ruggedness (CW, Fix Pin for P <sub>OUT</sub> = +29dBm with 50Ω Load)		10:1		N/A	No damage

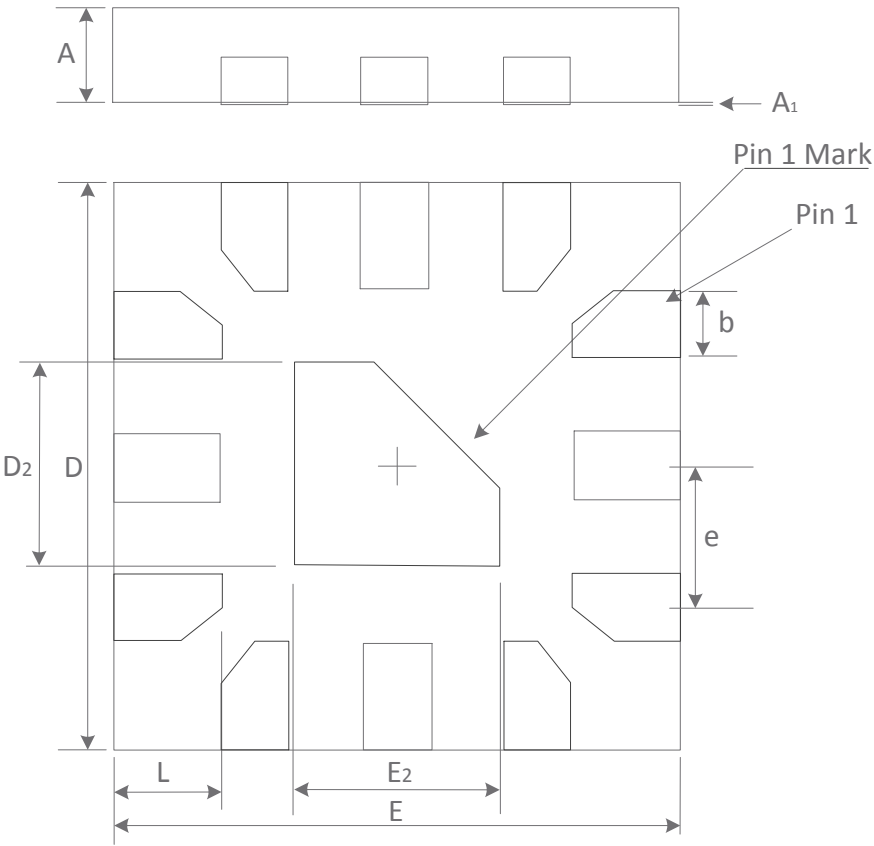

Dimensions (mm)			
	Min	Nom	Max
<b>A</b>	0.40	0.45	0.50
<b>A<sub>1</sub></b>	0.00	0.035	0.05
<b>b</b>	0.15	0.20	0.25
<b>D</b>		1.60	
<b>D<sub>2</sub></b>	0.40	0.50	0.60
<b>E</b>		1.60	
<b>E<sub>2</sub></b>	0.40	0.50	0.60
<b>e</b>		0.40	
<b>L</b>	0.35	0.40	0.45

Not to Scale

**PACKAGE MARKING**

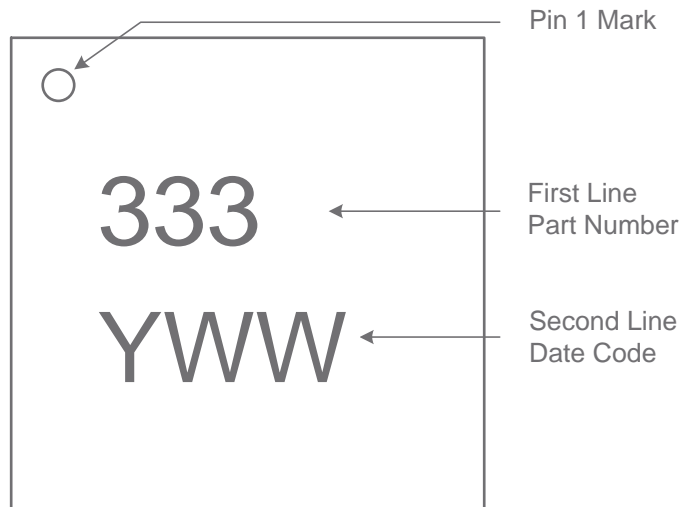

**CONTROL LOGIC TRUTH TABLE**

VC1	VC2	VC3	Mode of Operation
1	0	0	ANT Port to RF1 Port
0	1	0	ANT Port to RF2 Port
0	0	1	ANT Port to RF3 Port
0	0	0	Shutdown

*Notes: Other not-listed combinations are not recommended and supported.  
 "1" denotes high voltage stage (>1.2V) at Control Pin;  
 "0" denotes low voltage stage (<0.3V) at Control Pin*

**PCB LAND PATTERN**

