

DUAL, LOW VOLTAGE, LOW $R_{DS(on)}$, MOSFET H-BRIDGE CIRCUIT IN A PLASTIC PACKAGE

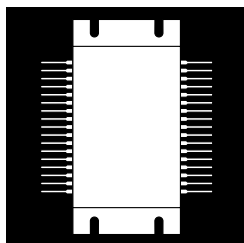

Dual 50 Volt, 15 And 20 Amp H-Bridge With Current And Temperature Sensing In A Low Profile Plastic Package

FEATURES

- H-Bridge Configuration
- Zener Gate Protection
- 10 m Shunt Resistor
- 2 Linear Thermal Sensors, One For Each Bridge
- Isolated Package
- Output Currents Up To 20 Amps

DESCRIPTION

This series of MOSFET switches is configured as a Dual H-Bridge with common V_{DD} lines, precision series shunt resistor in the source line, and sensing elements to monitor the substrate temperature of each switch. This device is ideally suited for Stepping Motor Control applications where size, performance, and efficiency are key.

2.1

MAXIMUM RATINGS ($T_C = @ 25^\circ\text{C}$)

Part Number	V_{DS} (Volts)	$R_{DS(on)}$ (m)	I_D (Amps)	Package
OMH310	50	100	15	MP-3
OMH315	50	70	20	MP-3

ABSOLUTE MAXIMUM RATINGS ($T_C = @ 25^\circ\text{C}$ unless otherwise noted)

Parameter	OMH310	OMH315	Units
Drain Source Voltage, V_{DS}	50	50	V
Drain-Gate ($R_{GS} = 1\text{m}$), V_{DGR}	50	50	V
Continuous Drain Current, $I_D @ T_C = 25^\circ\text{C}$	15	25	A
$I_D @ T_C = 70^\circ\text{C}$	11	16	A
Pulse Drain Current, $I_{DM}^{(1)}$	56	100	A
Maximum Power Dissipation, $P_D @ T_C = 25^\circ\text{C}^{(2)}$	20	50	W
$P_D @ T_C = 70^\circ\text{C}^{(2)}$	11	18	W
Linear Derating Factor, Junction-To-Case	0.2	0.33	W/C
Thermal Resistance, Junction-To-Case	5.0	3.0	$^\circ\text{C/W}$

Notes:

(1) Pulse Test: Pulse width 300 sec. Duty Cycle 1.5%. (2) Maximum Junction Temperature = 125°C .

OMH310 OMH315

ELECTRICAL CHARACTERISTICS: OMH310 (T_C = 25° unless otherwise specified)

Characteristic	Symbol	Min.	Typ.	Max.	Unit
----------------	--------	------	------	------	------

OFF CHARACTERISTICS

Drain-Source Breakdown Voltage, I _D = 250 μA, V _{GS} = 0	V _{(BR)DSS}	50	-	-	V
Zero Gate Voltage Drain Current = V _{GS} , V _{DS} = Max. Rat. V _{DS} = Max. Rat. x 0.8, T _C = 70°C	I _{DSS}	-	-	25.0	μA
		-	-	500.0	μA
Gate-Body Leakage, V _{GS} = ±12 V	I _{GSS}	-	-	±500	nA

ON CHARACTERISTICS

Gate-Threshold Voltage, V _{DS} = V _{GS} , I _D = 250 μA	V _{GS(th)}	2.0	-	4.0	V
Static Drain-Source On-Resistance, V _{GS} = 10 Vdc, I _D = 9.0 A T _C = 70°C	R _{DS(on)}	-	-	0.1	
		-	-	0.2	
On State Drain Current, V _{DS} > I _{D(on)} X R _{DS(on)} Max., V _{GS} = 10 V	I _{D(on)}	15	-	-	A

DYNAMIC CHARACTERISTICS

Forward Transconductance, V _{DS} > I _{D(on)} X R _{DS(on)} Max., I _D = 9.0A	g _{fs}	3.0	-	-	mho		
Input Capacitance	V _{DS} = 25 V, V _{GS} = 0, f = 1.0 MHz	C _{iss}	-	-	650	pF	
Output Capacitance			C _{oss}	-	-	450	pF
Reverse Transfer Capacitance			C _{rss}	-	-	280	pF

SWITCHING CHARACTERISTICS

Turn-On Delay Time	V _{DD} = 30 V, I _D = 3 A, R _{GS} = 50 Ω, V _{GS} = 10 V	t _{d(on)}	-	-	30	ns
Rise Time		t _r	-	-	85	ns
Turn-Off Delay Time		t _{d(off)}	-	-	90	ns
Fall Time		t _f	-	-	110	ns

SOURCE DRAIN DIODE CHARACTERISTICS

Source - Drain Current	I _{SD} = 13 A, di/dt = 100 A/μSec	I _{SD}	-	-	14	A
Source - Drain Current Pulsed		I _{SDM} *	-	-	56	A
Forward On-Voltage, I _{SD} = 28 A, V _{GS} = 0		V _{SD}	-	-	1.8	V
Reverse Recovery Time		t _{rr}	-	120	-	ns
Reverse Recovered Charge		Q _{rr}	-	0.15	-	μC

RESISTOR CHARACTERISTICS

Resistor Tolerance	R _s	9.0	10	11	m
Temperature Coefficient, -40°C to +70°C	T _{cr}	-	100	-	ppm

* Indicates Pulse Test 300 μsec, Duty Cycle 1.5%

ELECTRICAL CHARACTERISTICS: OMH315A ($T_C = 25^\circ$ unless otherwise specified)

Characteristic	Symbol	Min.	Typ.	Max.	Unit
----------------	--------	------	------	------	------

OFF CHARACTERISTICS

Drain-Source Breakdown Voltage, $I_D = 250 \mu A$, $V_{GS} = 0$	$V_{(BR)DSS}$	50	-	-	V
Zero Gate Voltage Drain Current = V_{GS} , $V_{DS} = \text{Max. Rat.}$ $V_{DS} = \text{Max. Rat.} \times 0.8$, $T_C = 70^\circ C$	I_{DSS}	-	-	250	μA
		-	-	750	μA
Gate-Body Leakage, $V_{GS} = \pm 12 V$	I_{GSS}	-	-	± 500	nA

ON CHARACTERISTICS

Gate-Threshold Voltage, $V_{DS} = V_{GS}$, $I_D = 250 \mu A$	$V_{GS(th)}$	2.0	-	4.0	V
Static Drain-Source On-Resistance, $V_{GS} = 10 \text{ Vdc}$, $I_D = 10 A$ $T_C = 70^\circ C$	$R_{DS(on)}$	-	-	0.07	
		-	-	0.14	
On State Drain Current, $V_{DS} > I_{D(on)} \times R_{DS(on)}$ Max., $V_{GS} = 10 V$	$I_{D(on)}$	20	-	-	A

DYNAMIC CHARACTERISTICS

Forward Transconductance, $V_{DS} > I_{D(on)} \times R_{DS(on)}$ Max., $I_D = 10 A$	g_{fs}	5.0	-	-	mho
Input Capacitance	$V_{DS} = 25 V$, $V_{GS} = 0$, $f = 1.0 \text{ MHz}$	C_{iss}	-	1020	pF
Output Capacitance		C_{oss}	-	500	pF
Reverse Transfer Capacitance		C_{rss}	-	120	pF

SWITCHING CHARACTERISTICS

Turn-On Delay Time	$V_{DD} = 30 V$, $I_D = 10 A$, $R_{GS} = 4.7 \Omega$, $V_{GS} = 10 V$, $R_L = 2.4 \Omega$	$t_{d(on)}$	-	-	50	ns
Rise Time		t_r	-	-	75	ns
Turn-Off Delay Time		$t_{d(off)}$	-	-	50	ns
Fall Time		t_f	-	-	50	ns

SOURCE DRAIN DIODE CHARACTERISTICS

Source - Drain Current		I_{SD}	-	-	25	A
Source - Drain Current (Pulsed)		I_{SDM}^*	-	-	100	A
Forward On-Voltage, $I_{SD} = 28 A$, $V_{GS} = 0$		V_{SD}	-	-	2.4	V
Reverse Recovery Time	$I_{SD} = 13 A, di/dt = 100 A/\mu\text{Sec}$	t_{rr}	-	100	-	ns
Reverse Recovered Charge		Q_{rr}	-	0.15	-	μC

RESISTOR CHARACTERISTICS

Resistor Tolerance	R_S	9.0	10	11	m
Temperature Coefficient, $-40^\circ C$ to $+70^\circ C$	T_{cr}	-	100	-	ppm

* Indicates Pulse Test 300 μsec , Duty Cycle 1.5%

2.1

SCHEMATIC

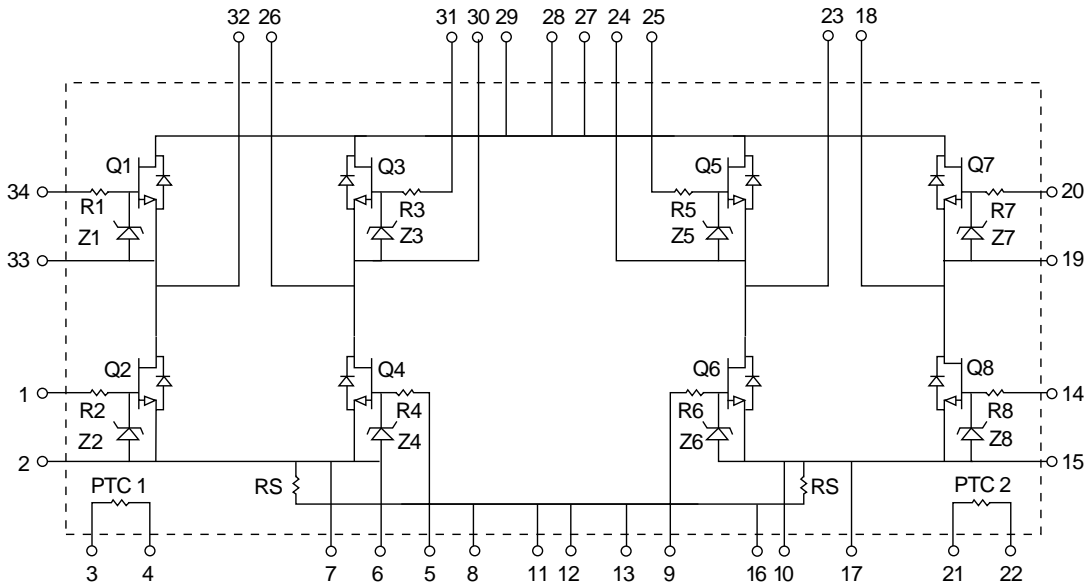

2.1

MECHANICAL OUTLINE

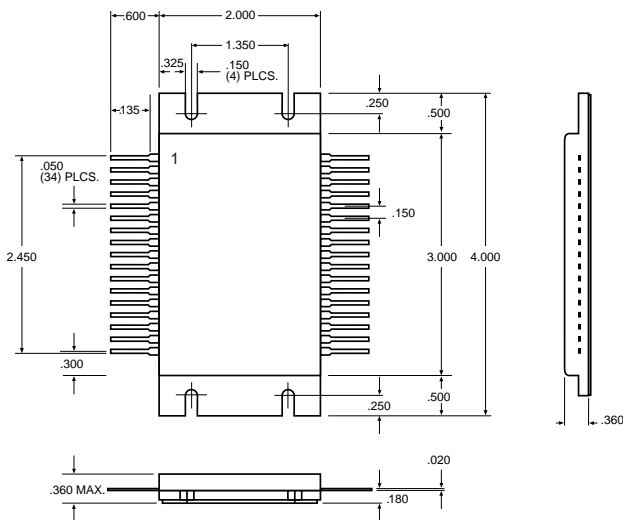

- | | |
|----------------------|------------------------|
| Pin 1: Gate Q2 | Pin 34: Gate Q1 |
| Pin 2: Source Q2 | Pin 33: Source Q1 |
| Pin 3: PTC 1 | Pin 32: Output Q1, Q2 |
| Pin 4: PTC 1 | Pin 31: Gate Q3 |
| Pin 5: Gate Q4 | Pin 30: Source Q3 |
| Pin 6: Source Q4 | Pin 29: V _M |
| Pin 7: Sense R 1 | Pin 28: V _M |
| Pin 8: Sense R 1 | Pin 27: V _M |
| Pin 9: Gate Q6 | Pin 26: Output Q3, Q4 |
| Pin 10: Source Q6 | Pin 25: Gate Q5 |
| Pin 11: Return Sense | Pin 24: Source Q5 |
| Pin 12: Return | Pin 23: Output Q5, Q6 |
| Pin 13: Return | Pin 22: +PTC |
| Pin 14: Gate Q8 | Pin 21: -PTC |
| Pin 15: Source Q8 | Pin 20: Gate Q7 |
| Pin 16: Sense R 2 | Pin 19: Source Q7 |
| Pin 17: Sense R 2 | Pin 18: Output Q7, Q8 |

Contact factory for lead bending options.
 Mounting Recommendations: Maximum Mounting Torque: 3.0 mN.
 The module must be attached to a flat heat sink (flatness 100µm maximum).