

Multi-Channel HDLC Protocol Controller

Description

The MHS 29C94 is a multi channel data link protocol controller device. It multiplexes/demultiplexes up to 32 full duplex data channels to support implementation of high speed data links based on either HDLC protocol or clear channel.

The device operates at layer 2 of the OSI (Open System Interconnection) model as described by ISO (International Organization for Standardization). It resides between a L.I.U. and a framer PCM devices such as, respectively, the MHS 29C3XX and 29C96, and a memory shared with a system host microprocessor.

The 29C94 processes transmit and receive data on a PCM communication medium in either the CEPT (2.048 Mbps) or the T1/DS1 (1.54 Mbps) framing format. The device provides HDLC formatting/extract functions for synchronous data and manages, for each of the active data channels, access to buffers into the shared memory.

Provisions to operate in clear channel, non-HDLC mode, are readily available and can be programmed on any channel independently of every others.

The circuit is entirely compatible with ISDN specified by CCITT and supports connections of computers through the ISDN at the primary rate in HDLC protocol format. It also supports modes 0, 1, 2 and 3 of the DMI protocol for clear channels transmission of data at 64 kbps.

The 29C94 device provides additional functions which support ISDN hyperchannel and users defined protocols, and insure full compatibility with X25, LAPB and LAPD protocols.

These features allow the use of the 29C94 in a wide range of applications that go beyond the ISDN HDLC data links.

The 29C94 finds applications in several areas of telecommunication. This includes multimedia terminals and servers, network couplers (STARLAN, ETHERNET, ...), PABX signaling, PABX to Computers links, etc.

Features

- Single chip CMOS monolithic device simplifies ISDN/DMI implementation
- Compatible with 2.048 Mbps CEPT and 1.544 Mbps T1/DS1 PCM framing format.
- Provides HDLC or clear channel formatting for up to 32 full duplex, 64 kbps channels.
- On chip receive and transmit context saving as well as buffer memory management function.
- Provides 64 DMA channels (32 transmit, 32 receive), 8-bit data bus, 24-bit address, bus request/acknowledge, handshake
- Provides any user defined hyperchannel and ISDN standard hyperchannel options (CCITT I.412), - H₀ (384 kbps),
 - H₁₁ (1.536 Mbps),
 - H₁₂ (1.920 Mbps).
- On board 16-bit CRC generation and checking using CCITT polynomial, automatic flag detection and transmission, zero-bit insertion and deletion
- Independent and flexible transmit/receive PCM serial link
- Independent report on every transmit/receive channel activities through interrupt requests.
- Compatible with Motorola 680X0 and Intel 80X86.
- Programmable number of channel from 2 to 32 and loop back mode operations for test purposes.
- Operates from a single 5 V power supply.
- Packaged in 68 pin PLCC

Interface

The 29C94, multi-channel HDLC controller, transmits data to, and receives data from, a Line Interface Unit (L.I.U.) PCM transceiver and framer such as MHS 29C3XX associated to the 29C96 in ISDN/DMI primary rate (2.048/1.544 Mbps). It stores

and fetches the data to and from buffers allocated into an external memory, shared with the system host microprocessor as illustrated in the application example of Fig. 1.

Figure 1. Typical Application

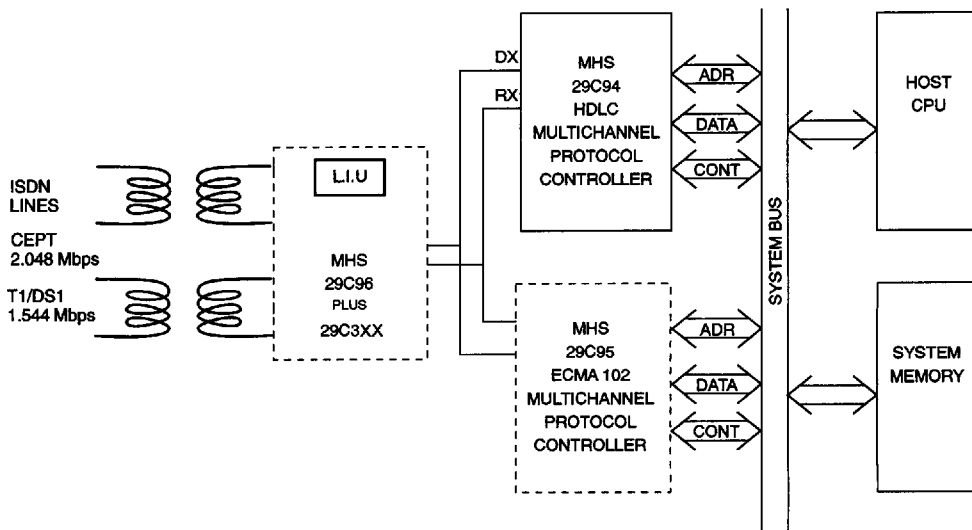

29C94 pin assignments are shown on fig 2. Definitions of interface signals are given on Table 1.

Figure 2a. 29C94 Pin out.

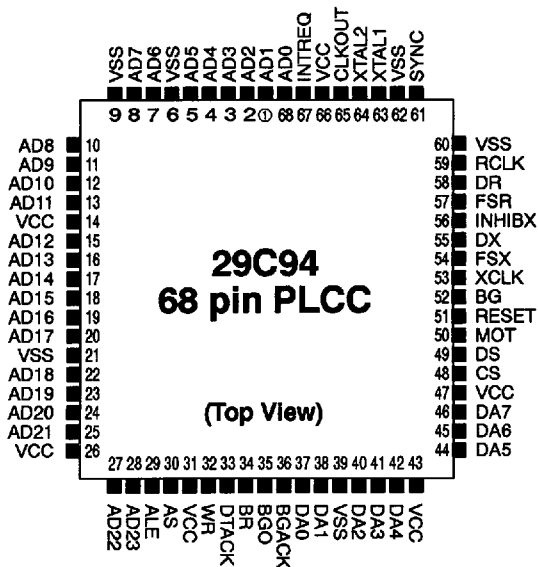

Figure 2b. Pin assignments

PIN#	I/O	PIN#	I/O	PIN#	I/O	PIN#	I/O	PIN#	I/O	PIN#	I/O
- 68	AD ₀	- 15	AD ₁₂	- 37	DA ₀	- 33	DTACK	- 55	DX	- 47	V _{CC}
- 1	AD ₁	- 16	AD ₁₃	- 38	DA ₁	- 34	BR	- 58	DR	- 66	V _{CC}
- 2	AD ₂	- 17	AD ₁₄	- 40	DA ₂	- 52	BG	- 56	INHIBX	- 6	V _{SS}
- 3	AD ₃	- 18	AD ₁₅	- 41	DA ₃	- 35	BGO	- 61	SYNC	- 9	V _{SS}
- 4	AD ₄	- 19	AD ₁₆	- 42	DA ₄	- 36	BGACK	- 50	MOT	- 21	V _{SS}
- 5	AD ₅	- 20	AD ₁₇	- 44	DA ₅	- 49	DS	- 63	XTAL1	- 39	V _{SS}
- 7	AD ₆	- 22	AD ₁₈	- 45	DA ₆	- 67	INTREQ	- 64	XTAL2	- 60	V _{SS}
- 8	AD ₇	- 23	AD ₁₉	- 46	DA ₇	- 51	RESET	- 65	CLKOUT	- 62	V _{SS}
- 10	AD ₈	- 24	AD ₂₀	- 48	CS	- 53	XCLK	- 14	V _{CC}		
- 11	AD ₉	- 25	AD ₂₁	- 29	ALE	- 59	RCLK	- 26	V _{CC}		
- 12	AD ₁₀	- 27	AD ₂₂	- 30	\overline{AS}	- 54	FSX	- 31	V _{CC}		
- 13	AD ₁₁	- 28	AD ₂₃	- 32	WR	- 57	FSR	- 43	V _{CC}		

2

Table 1 : 29C94 Interface Signal Definitions.

Symbol	Type	Name & description	Active Mode	
			INTEL	MOTOROLA
SYSTEM BUS INTERFACE - BUS MANAGER -				
AD ₀ -AD ₂₃	I/O	Address bus. Bidirectional address lines between 29C94 and the buffers or the host CPU and 29C94 internal registers.	N.A	N.A
DA ₀ -DA ₇	I/O	Data lines. Bidirectional data lines between 29C94 and the buffers or the host CPU and 29C94 internal registers	N.A	N.A
CS	I	Chip select. Active low.	LOW	LOW
ALE	I/O	Address Latch Enable. Tied to ground in MOTOROLA mode. A valid address is present on the address lines when ALE goes high in INTEL mode.	HIGH	N.A
\overline{AS}	I/O	Address Strobe in MOTOROLA mode. Read strobe in INTEL mode	LOW	LOW
WR	I/O	Write Strobe, to perform either a data write cycle into the system memory or a CPU write cycle into the 29C94 internal memory.	LOW	LOW
DTACK	I/O	Read/write acknowledge. As an input, acknowledges DMA read or write cycles. As an output, acknowledges a CPU read or write cycle into the 29C94 internal RAM/registers.	HIGH	LOW
BR	O	Bus request. Open collector output to request system bus control take over.	LOW	LOW
BG	I	Bus grant. To signal that 29C94 is granted system bus control.	HIGH	LOW
BGO	O	Daisy chain bus grant output. In a daisy chain, level asserting that system bus control is granted to a daisy chained device.	HIGH	LOW
BGACK	I/O	Bus grant acknowledge output. Acknowledges that system bus is under 29C94 control.	N.A	LOW
		Daisy chained bus request input. Forwards a bus request in a daisy chain.	LOW	N.A
DS	I	Data strobe. Pulse to read from, or write data into the 29C94	N.A	LOW
INTREQ	O	Interrupt request. Level to call host CPU attention after a buffer closing.	HIGH	HIGH
RESET	I	RESET. Pulse to reset global mode control registers. Minimum pulse width is two PCM frame periods. Reset causes the 29C94 to default in HDLC mode, de-activates all channels, puts all 0s in fill/mask.	HIGH	LOW

Table 1 : 29C94 Interface Signal Definitions.

Symbol	Type	Name & Description	Active Mode
<i>PCM HANDLER</i>			
XCLK	I	Transmit bit clock. Square wave input from the LIU clock generator providing the master timing source for the transmit channel. Frequency is 2.048/4.096 Mbps in CEPT, or 1.544/3.088 Mbps in T1/DS1.	
RCLK	I	Receive bit clock. Same as the XCLK input, except that applies to the receive channel	
FSX	I/O	Transit frame sync. Pulse for frame synchronisation. Frequency is 8 kHz. Input in slave operating mode Output in master operating mode.	HIGH
FSR	I/O	Receive frame sync. Same as the FSX input, except that applies to the receive channel	HIGH
DX	O	Transmit data. Output of 29C94 to the LIU representing the transmit serial data bit stream.	
DR	I	Receive data. Input from the LIU representing the received serial data bit stream.	
INHIBX	O	Transmit time slot inhibit. Level to the LIU asserting that transmit function of current time slot is inhibited.	HIGH
SYNC	I	Sync. Input from the LIU asserting that receive PCM from alignment is correct.	HIGH
<i>OPTIONS</i>			
MOT	I	MOTOROLA/INTEL. Input to select system bus interface type. Low level input selects INTEL interface, high level input selects MOTOROLA interface.	
XTAL1	I	Input of crystal oscillator or external chip clock.	
XTAL2	O	Crystal oscillator output.	
CLKOUT	O	Chip clock buffered output.	
VCC	I	SUPPLY + 5 Volt power supply.	
VSS	I	GROUND. Power supply ground.	

1.0 Functional Description

The 29C94 multiplexes/demultiplexes up to 32 full duplex channels over the time slots of the PCM frames. Two or more, adjacent or non adjacent, time slots may be dynamically concatenated to form an hyperchannel.

Data to be transmitted are fetched through DMA cycles in 8-bit parallel form, time slot after time slot, from the buffers; they are processed by performing protocol data formatting and rate adaptation, then transmitted in serially to the PCM link.

Conversely, the incoming stream of serial data is processed, channel by channel, by performing rate adaptation and data frame protocol deformatting; received data are stored, through DMA cycles, in 8-bit

parallel form into the channel allocated buffers.

Each channel is allocated eight chained buffers to transmit data and the same amount on receiving side. Buffers have a maximum capacity of 64 kbytes.

Overall 29C94 can address up to 512 buffers of 64 kbytes each.

The internal functions of the 29C94, controlled by the registers, are partitionned into 5 major operating logic blocks as shown in Fig. 3 below.

- 1 - PCM HANDLER, 2 - HDLC PROCESSOR,
- 3 - DMA CONTROLLER, 4 - BUS MANAGER,
- 5 - CONTEXT MONITOR.

Figure 3. 29C94 Functional Block Diagram

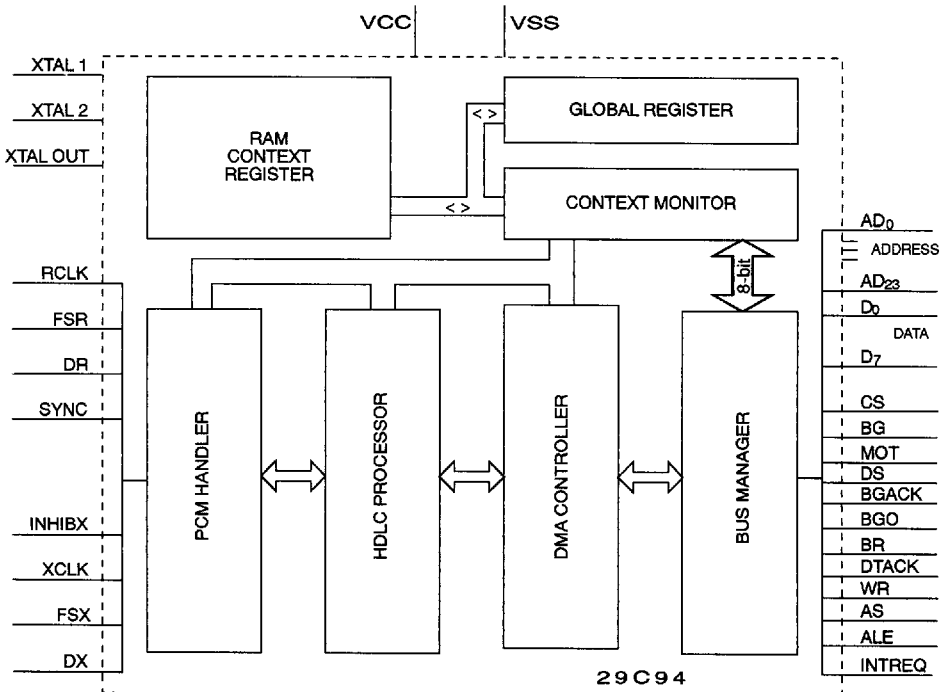

29C94

Each channel is processed depending on the operating modes specified by the device internal control registers that the host CPU initializes and sets up. Device initialisation is explained later on when describing the details of the registers. Two types of operating modes are programmable.

A) - Global operating mode : It applies to every channels and selects :

- CEPT 32 channels vs - T1/DS 24 Channels
- Test mode vs - (CEPT1/DS1) mode
- PCM Slave mode vs - PCM Master mode
- PCM Simple clock mode vs - PCM Double clock mode (GCI)
- All channels valid vs - All channels unvalid
- PCM frame sync offset control.
- Loop back operation for test purpose

Specifying the global operating mode requires six 8-bit words. Eight more bytes of global registers are reserved for interrupt request purposes, which the 29C94 initiates itself.

B) - Channel operating mode :

Within the global mode, it is programmable on any channel independently of every others. Furthermore,

on any channel, the receive mode is independent of the transmit mode.

For both, transmit and receive sides, the programmable channel mode parameters are :

- HDLC mode vs - Clear channel mode
- Time slot valid vs - Time slot unvalid
- Flag sharing enable/disable (Transmit only)
- Rate adaptation/fill-mask,
- Channel number,
- Buffers descriptors/ : Buffer size/word count (16 bits),
- DMA descriptors Start address (24 bits), Processing status.

Receive and transmit parameters that are specific to a time slot and that control the data processing during that time slot will be referred thereafter as the "time slot context" or "context". They are maintained inside the 29C94, stored in an internal RAM and accessed through the "CONTEXT MONITOR" functional logic block. Context specification is allocated 128 bytes per time slot : 64 bytes for transmit context and 64 bytes for the receive context.

Mapping of the internal RAM is shown table 2 below. Register definitions and functions are given starting on chapter 3.0.

Table 2 : Register Mapping into Internal RAM.

Modes		Addresses	RAM/Register Mapping
C H A N N E L	R E C E I V E	0H to 3FH	Receive context ; Time slot 0
		40H to 7FH	Receive context ; Time slot 1
	
		...	Receive context ; Time slot N-1
		...	Receive context ; Time slot N
		...	Receive context ; Time slot N+1
	
		7A0H to 7CFH	Receive context ; Time slot 30
		7C0H to 7FFH	Receive context ; Time slot 31
		M O D E	T R A N S M I T
840H to 87FH	Transmit context ; Time slot 1		
...		
...	Transmit context ; Time slot N-1		
...	Transmit context ; Time slot N		
...	Transmit context ; Time slot N+1		
...		
F80H to FBFH	Transmit context ; Time slot 30		
FC0H to FFFH	Transmit context ; Time slot 31		
GLOBAL MODE			

Global operating mode parameters are permanently applied to the functional logic blocks as they do not change from one time slot to the other, except for a deliberate CPU intervention. On the contrary, the context parameters, pertaining to a specific time slot, are switched on every time slot. Context switching is performed by the CONTEXT MONITOR, as explained further on.

To summarize : On each successive time slot of the PCM frame and within the global operating mode, specific time slot context is retrieved from the internal RAM at the beginning of the time slot. Processing actions then take place over the time slot length, according parameters of the context, which, by the end of the slot, is updated and saved until its next occurrence in the PCM frame, 125 μ s later.

Let us remark that during a time slot (3.9 μ s in CEPT), assuming it is valid and there are data being received and transmitted on this channel, several discrete actions are taking place ; ie. Context restoring-updating-saving, data fetching (transmit) and storing (receive), current CRC computation, serial data processing (transmit/receive), etc... To do so, the 29C94 operates at an internal frequency of up to 33 MHz (30 ns period) driven either by an external clock or an internal crystal oscillator as shown on AC Electrical Characteristics. Furthermore, the 29C94 uses throughout its synchronous design a pipeline architecture. Pipeline operations are illustrated fig. 4 below.

The CONTEXT MONITOR also provides, through the BUS MANAGER, a path to the host CPU for accessing the internal RAM and thus, all registers.

Figure 4. Context Monitor pipe-line.

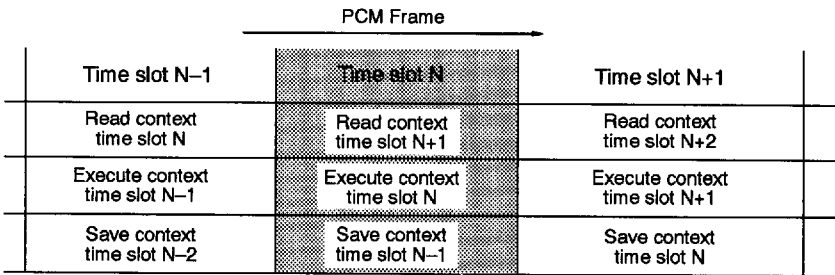

2.0 Functional Logic Blocks

Functional logic blocks performances are controlled and driven from the global and context registers, which mapping in the 29C94 internal RAM is shown in Table 2. A quicker understanding of the logic blocks operations will be helped by looking at details of the control register contents in the "REGISTER DEFINITION", starting on chapter 3.0.

2.1. PCM Handler

The PCM HANDLER is mostly controlled by the global registers : *MODE*, *ROFFSET*, *XOFFSET*, *GLOBINH*, *TEST* and *TESTEXT*. It transmits, on DX output, and receives, on DR input, serial data from a L.I.U. device as shown in fig.1. It performs receive/transmit data synchronization using XCLK and RCLK clock inputs and generates an internal reference, bit 0/time slot 0, with an adjustable offset

against the external PCM frame syncs, FSR/FSX. It also supplies the bit clock to the HDLC PROCESSOR logic block.

The whole 29C94 is programmable in either master or slave mode with respect to FSX and FSR frame sync (see *MODE* global register on chapter 3.2).

SLAVE mode : Frame sync, FSX/FSR, and bit clock, XCLK/RCLK, are input signals. Width of FSX/FSR pulses must be at least one XCLK/RCLK period.

MASTER mode : The 29C94 generates the frame sync FSX/FSR. They are derived from XCLK/RCLK bit clock inputs. FSX/FSR pulse widths are equal to one XCLK/RCLK period.

XCLK and RCLK bit clocks may be asynchronous, however the loop back mode is not then possible.

DX output driving mode is programmable as "tri-state", or "always high" or "wired OR" (See

29C94

DXC0, DXC1 in *MODE* chapter 3.2). DX is forced to "1" or high impedance when the time slot is not valid.

SYNC input is used in conjunction with a FRAMER device, such as the MHS 29C96. SYNC asserts the status of the received frame, according the truth table below.

SYNC	"1"	"0"
Frame	synchronized	not synchronized

When SYNC goes low, incoming data is ignored on every time slot and a bit (Lsyn) is automatically set into *RCTST* status registers of all channels (Receive DMA descriptors chapter 3.11). Received data will again be only considered and only stored after SYNC recovery.

Whenever a framer device is not used, the SYNC input pin must be tied to Vcc.

INHIBX asserts that the current time slot is inhibited. This output goes high, one bit clock period before the related time slot. INHIBX may be used with a framer

device to force a preset idle code during the inhibited time slot. That feature is specially usefull with AMI coding in T1/DS1 application.

FRAME SYNC OFFSET (*ROFFSET* and *XOFFSET* registers, chapter 3.3)

Because of inherent design delays, the internal PCM frame reference-bit 0/time slot 0 – must be shifted so that, seen from the outside, it appears in sync with the FSX/FSR PCM link. Offsets are separately programmable on both transmit and receive side, either in CEPT or T1/DS1 mode.

Programming resolution is one bit clock period (1/2 bit clock resolution in double clock mode). Loop back mode is only possible when transmitter and receiver are synchronous and that transmit and receive channels are aligned. That is to say when both the external transmit and receive time slot references appear at the same time (same bit clock, same FRAME SYNC as shown fig 6). Fig. 5 below, shows the natural internal reference offsets against the external FSX/FSR ISDN line.

Figure 5. Internal References and Offsets.

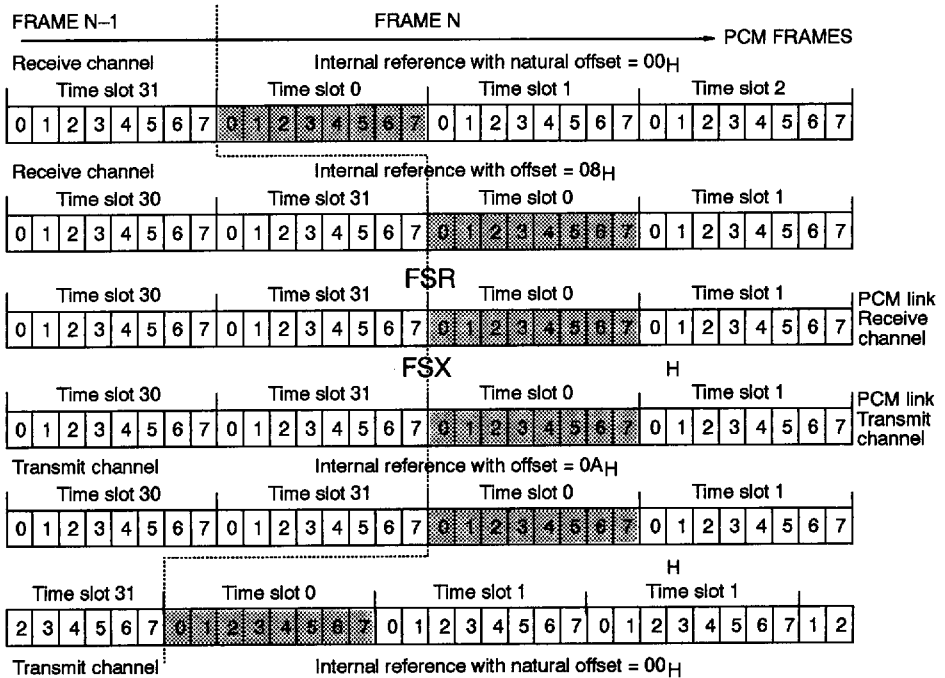

Natural offset values are 8 bit clock on the receive side and 10 bit clock on the transmit side. Thus, assuming that a given application brings in additional delay worth N bit clock, the minimum offset programming on the *ROFFSET* register becomes $08_H + N$ ($10_H + 2N$ in double clock mode) and will be $0A_H + N$ ($14_H + 2N$ in double clock mode) on the *XOFFSET* register.

Delays on transmit and receive channels were designed different because of 29C94 synchronous design and its full duplex capability. On every time slot the transmit channel is processed first, two bit clock periods ($1 \mu s$ in CEPT mode) before the receive channel. A side effect of this feature is to possibly

allow, on a given time slot, a successful receive DMA cycle completion, even if a time out has occurred on the transmit DMA cycle.

As shown on the diagram figure 6, in slave mode, single clock, assuming that the transmit offset register is properly set, bit 0/time slot 0 of the transmit frame is output on first XCLK rising edge after FSX has been sampled to 1 by XCLK falling edge.

Similarly, if the receive offset register is correctly set, bit 0/time slot 0 of the received frame is sampled on the first RCLK falling edge after FSR was sampled to 1 by RCLK falling edge.

Figure 6. Offset Programming.

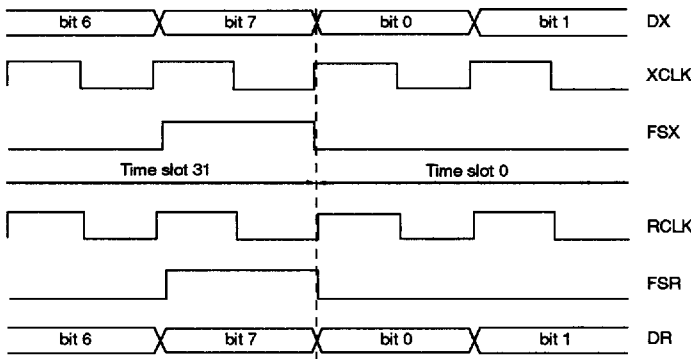

2.2. HDLC Processor

The HDLC PROCESSOR logic block is mostly driven and controlled by the context HDLC descriptor. It receives data bytes from the DMA CONTROLLER, processes and transfers them in series, LSB first, to the PCM HANDLER. Conversely, it receives data in series from the PCM HANDLER and, processes and sends them in byte form to the DMA CONTROLLER. The HDLC PROCESSOR also performs data rate adaptation with fill registers (transmit) or mask registers (receive).

The HDLC PROCESSOR is shared and successively used by all channels of the PCM frame. It is programmable in either HDLC or clear channel mode (see *RMOD* and *XMOD* registers, chapter 3.7).

HDLC Mode

In that mode basic HDLC frame formatting is performed, as shown in figure 7.

Figure 7. HDLC Framing Format

$7E_H$	$N \times 8$ bits	2×8 bits	$7E_H$
Flag	Data	CRC	Flag

Frame check sequence (CRC) is computed from CCITT polynomial: $X^{16} + X^{12} + X^5 + 1$. Frame length is 64 bytes maximum, plus flags and CRC. A data frame is always contained into one single buffer.

On any channel, flag sharing capability between successive transmitted data frames is programmed by setting up to "1" the *FLG*-bit into the *XMOD* register. In that mode the same flag may close a data frame and open the next frame.

Transmit :

Upon transmission the HDLC PROCESSOR performs protocol formatting and composes the HDLC frames with the data fetched in the buffers by the DMA CONTROLLER. It generates flags, abort

29C94

and idle codes, inserts one "ZERO" after five consecutive "ONES" and computes the HDLC frame check sequence (CRC).

Flags are stuffed when there is no valid data to transmit while the time slot is valid.

Data frame closing occurs when either the related transmit data buffer is empty, (word count = 0), or after an unsuccessful DMA attempt (time-out).

In the first case, a flag closes the frame and flags proceed to be sent while the time slot is valid with no data to transmit. In case of time out, the frame is closed with an Abort (FF_H) character. In both cases, a report is assembled and stored in the *XCTST* register of the related DMA descriptor.

Receive :

On the receive side, the HDLC PROCESSOR extracts serial data from the incoming stream on PCM HANDLER and performs protocol deformatting. It detects flags, abort and idle codes, suppresses inserted zeroes, checks the HDLC frame check sequence (CRC). The resulting serial data is transferred to the DMA CONTROLLER to be stored in the buffers. All incoming bits following the detection of a flag (7E_H) are assembled in byte character.

Frame reception may be interrupted for various reasons outlined below. In all cases, the cause is reported, as explained hereafter, and stored into the related *RCTST* register of the DMA descriptor.

- Closing flag (7E_H) detection (FTR bit set to "1"),
- abort character (FF_H) detection (ABRT bit set to "1")
- lost of Sync, (SYNC, pin# 61, = 0), (LSYN bit set to "1")
- buffer full with yet a byte to store, (UDF bit set to "1")
- DMA attempt is unsuccessful, (TOUT bit set to "1")
- attempt to use an unvalid buffer, (DONE bit set to "1")

A minimum of 3 bytes (1 data byte + CRC) is required between 2 flags.

CLEAR Channel Mode

Flag generation/detection, bit insertion and CRC computing are disabled in clear channel mode. Buffers are automatically chained, one after another. Frame length is not limited to one buffer as in HDLC mode.

"Ones" are transmitted when data are not available or upon a DMA time out. As in HDLC mode, a status is assembled in that later event (*RCTST* and *XCTST* status registers, chapter 3.11).

If the DMA CONTROLLER chains to a DMA descriptor that is not empty, then writing is not executed in the pointed buffer neither in the status register. Data characters alignment is kept on the PCM time slot. Following is an example of transmit/receive clear channel, 64 kbps, on time slot i.

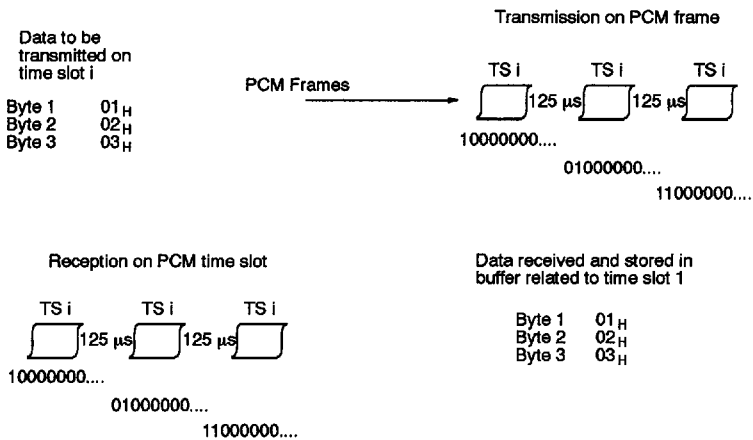

Hyperchannel

In both, HDLC or Clear channel modes, data may be received or transmitted over an **hyperchannel** that is made of the concatenation of adjacent, or

non-adjacent, time slots as shown on fig.8, where the CEPT frame is represented.

Figure 8. 512 kbps hyperchannel

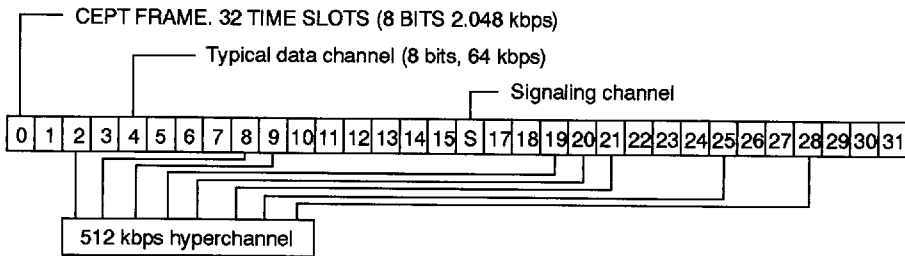

The example illustrates a 512 kbps hyperchannel made of eight adjacent *and* non-adjacent time slots within the CEPT frame. This results in a PCM frame with twenty five channels. Twenty four of them are single 64 kbps channels and the last is the 512 kbps channel. Up to 31 time slots can be concatenated to form a 1.984 Mbps hyperchannel.

A time slot is recognized as part of an hyper channel when its "channel number" is different from its time slot number. The PCM counters ("Transmit/receive") keep track of the time slot number while the channel number is user defined and stored into the related **RMOD/XMOD** register in the HDLC descriptor part of the time slot context.

Rate Adaptation (See **RSPEED** and **XSPEED** registers)

Receive and/or transmit data rate is adaptable on every channel. Basic 64 Kbps rate may be adapted to subrates that are 8 kbps multiples (8, 16, 24, ..).

Fill/mask registers are applied to shift registers that data is passing through as illustrated in fig. 9a and 9b.

Figure 9a. Transmit Rate Adaptation : Single transmit channel 24 kbps.

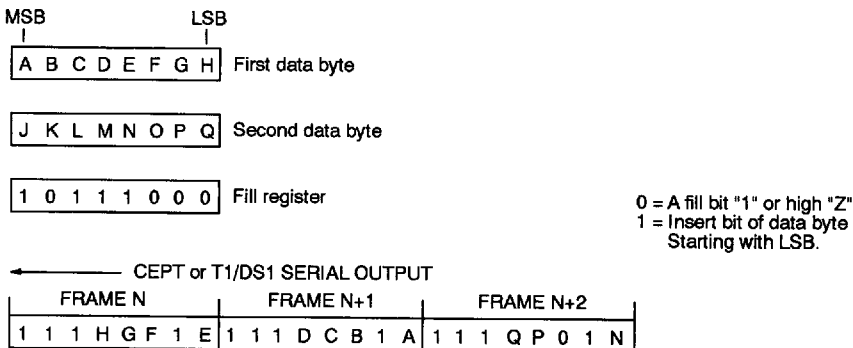
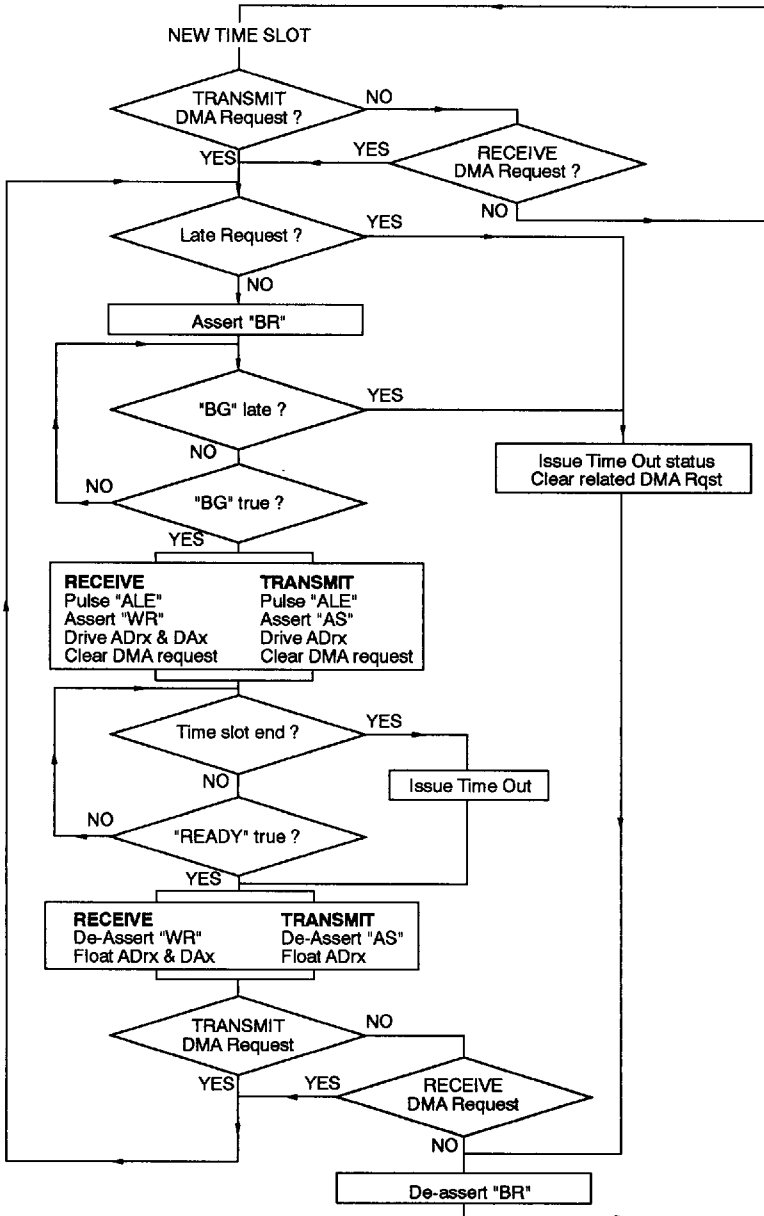

Figure 10. DMA cycle with INTEL host CPU.



Note : Transmit and/or receive DMA requests rise, if they are present, when time slot begins.

As soon as the system bus is granted, the transmit DMA cycle starts with AD (23:0) address output on system bus and AS/ALE/WR signals being asserted.

The cycle ends with a DTACK (see DMA flow chart on figures 10 and 11).

Receive :

The whole process for DMA transfer of received data is very much like the transmit one, except that buffer status and buffer indexes are respectively reported in receive channel RCTST and RSTAT1 registers. In the same way, buffer switching is reported in ITR(x) thus triggering an interrupt request, which is CPU processed as explained above.

is automatically closed and the 29C94 looks up for next opening flag.

If a time out occurs, the current buffer is closed, the buffer index incremented but the incoming data stream is ignored until detection of a new flag.

If the buffer index points to a DMA descriptor that has an exhausted buffer (DONE not reset), then writing into the buffer will not be allowed nor in the RCTST register.

The receive DMA cycle starts with address, AD (23:0), and data, DA (7:0), output on system bus, and AS/ALE/WR signals being asserted. The cycle normally ends with DTACK (write acknowledge) asserted before the end of time slot.

If all DMA buffers are exhausted, current buffer incrementation is stopped until buffers are re-initialized by CPU. Then flags are forced on transmit side and the receiver ignores incoming data stream.

In case of overflow (WC=0 and frame not finished) or in case of loss of sync (SYNC = 0) the current buffer

2.4. Bus Manager

The BUS MANAGER interfaces the 29C94 internal logic blocks with the system bus (see fig. 3). MOT input (pin#50) selects either INTEL or MOTOROLA interface types. The BUS MANAGER responds to commands originating from the DMA CONTROLLER (DMA request), or from the interrupt registers, or from the host CPU. The BUS MANAGER performs system bus take over for DMA cycles. Also, upon buffers switching, it generates interrupt requests that call for CPU actions. System bus take-over is accomplished after a bus request/bus grant hand-shake with the host CPU (BR pin#34/BG pin#52), authorizing the BUS MANAGER to drive the system bus. Timing diagrams are shown on chapter 6.1 to 6.9 for an INTEL CPU and chapter 7.1 to 7.9 for a MOTOROLA CPU.

CPU Access

The CPU accesses the global registers (Read/write) within three XTAL1 clock cycles maximum. Context registers access needs six XTAL1 periods maximum. Timing diagrams are shown on chapters 6.3 and 6.4 for INTEL CPU and chapters 7.3 and 7.4 for MOTOROLA.

The internal RAM looks like a dual port memory, which access is managed by the CONTEXT MONITOR. One port, 8-bit wide, is the path for the CPU through the BUS MANAGER, the other port, 16-bit wide, is the path to the functional logic blocks (see fig. 3 – 29C94 block diagram).

Because of delays to clock in and out of the RAM the context data (128 bytes to save/retrieve), compounded by the RAM own access time, the XTAL1 clock frequency cannot go lower than a limit fixed by the conditions listed below – worst case CEPT mode, shortest 3.9 μ s time slot :

1. - $3.9 > (2/F) \times (44+N)$
2. - $3.9 > (1/F) \times 5N$
3. - $3.9 > ((2/F) \times N) * 3$
4. - $3.9 > (1/FCPU) \times I \times N$

Where N = number of CPU access to the internal RAM,
 F = XTAL1 frequency in MHz,
 I = maximum number of CPU clock periods for one R/W access.

The 29C94 data bus interface, D₀ through D₇, needs to be only 8-bit wide due to the low demand in data exchange. The interface address bus is 24-bit wide, AD₀ through AD₂₃, allowing 512 buffers of 64 kbits each. Only bit AD₀ through AD₁₂ are used when the CPU accesses the 29C94 internal RAM/registers. The 29C94 automatically generates the acknowledgement, DTACK (pin#33), (READY in INTEL mode), when its RAM/registers are being accessed. It also waits for DTACK (READY in INTEL lode) acknowledgement to complete a DMA cycle.

29C94

1. Is the condition for a full transmit/receive context exchange.
2. Reflects that the CPU read or write cycle into context registers, takes a minimum of five XTAL1 periods.
3. Is related to the design of the CONTEXT MONITOR that allows one CPU access every two RAM accesses.
4. Relates to the CPU own read/write limitations.

With the recommended XTAL1 clock frequency of $F = 33 \text{ MHz}$, in CEPT mode, all conditions are true. Then 22 R/W accesses may be completed on the CPU port, thus giving it a bandwidth of 5.64 Mbytes/s. That throughput allows the host to update DMA descriptors of a given channel while the DMA CONTROLLER is using part of the descriptor. The conditions also apply to T1/DS1 mode, except that the time slot lasts $5.2 \mu\text{s}$ instead of $3.9 \mu\text{s}$.

DMA Cycle

Upon DMA request, the BUS MANAGER issues a bus request, BR, and wait for BG, the bus grant signal. Additionally, in MOTOROLA mode, a bus grant acknowledge (BGACK) is issued by the 29C94.

In MOTOROLA mode BR/BG handshake begins the DMA cycle, and the BGACK output is kept true until the end of the cycle. In INTEL mode BR is kept true until the end of the cycle.

Over the whole cycle, the 29C94 controls the system bus. It drives the 24 bit address, the AS (READ), WR, ALE (in INTEL mode), strobes, and, for data write, the DATA lines. It checks for DTACK (READY).

AS (READ) WR and ALE (in INTEL mode) are de-asserted ($AS=WR=1$, $ALE=0$) at the beginning of the cycle, and de-asserted again by the end of the cycle.

Such feature simplifies the application design when selecting PULL-UP and PULL-DOWN resistors.

Daisy Chain Mechanism

The 29C94 includes an internal daisy chain logic circuit to help designing systems built with several devices that have, each, a system bus control take over capability. The internal daisy chain control saves PC board space compared to using a bus arbiter circuit.

DMA timing considerations

At the beginning of a time slot, the BUS MANAGER scans for transmit and/or receive DMA request. If at least one is true, the DMA cycle starts. Therefore, on a given time slot, there may be :

- No DMA or,
- either one read or one write cycle (either transmit or receive), or
- two cycles, one read and one write.

The BUS MANAGER checks that DMA cycle completion has, or may occur. According to the conditions, it will take the following actions :

- De-assert BR, bus request, if BG, bus grant, is not yet true by the end of time slot,
- abort the read or write cycle, de-assert BR and release the system bus, if memory acknowledge is not true before time slot end,
- abort the DMA cycle, if BG is asserted close to the end of the time slot, which would make a read or write cycle impossible.

In all cases, a time out status is reported causing a data frame abort on transmit side or a frame error on the receive side. The longest period allowed to achieve a DMA cycle is DELMAX and is worth :

$$\text{DELMAX} = (\text{Time slot period}) - (0.5 \text{ bit-clock periods}) - (4 \text{ XTAL1 periods})$$

If XTAL1 frequency is the recommended 33 MHz, then :

$$\text{DELMAX} = 3.5 \mu\text{s in CEPT mode or } 4.6 \mu\text{s in T1/DS1 mode}$$

Deadlock cannot occur because the circuit automatically recovers from unsuccessful DMA attempt, such as trying to write or read into unexisting buffer addresses. When one read and one write cycle are requested on a given time slot, the BUS MANAGER does not de-assert BR after completion of the first cycle to save bus grant latency time.

Table 3 : Daisy Chain Truth Table

Signals		MOTOROLA	INTEL
BUS REQUEST OUTPUT	- BR	LOW	LOW
BUS GRANT INPUT	- BG	LOW	HIGH
DAISY CHAIN BUS REQUEST INPUT	- BGACK	N.A	LOW
BUS GRANT ACKNOWLEDGE OUTPUT	- BGACK	LOW	N.A
DAISY CHAIN BUS GRANT OUTPUT	- BGO	LOW	HIGH

In INTEL mode (Fig. 12a), the 29C94 senses, the daisy chain bus request BGACK. When true the 29C94, forwards its own bus request, BR, on the chain. The last 29C94 waits for bus grant, BG, and, when

true, will forward it back to its BGO output if no DMA is requested from the DMA CONTROLLER. Internal DMA requests have priority over the daisy chain request and are executed first.

Figure 12a. INTEL Daisy Chain

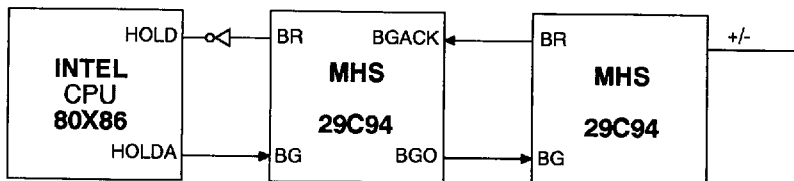

In MOTOROLA mode (Fig. 12b), all the devices in the chain issue their bus request, BR, on the same line. Only the bus grant, BG, is chained. When a 29C94 receives a bus grant on its BG input, it forwards it to

its bus grant output, BGO, along the chain if no internal DMA is requested from the DMA CONTROLLER. Again DMA requests have priority over the daisy chain request.

Figure 12b. MOTOROLA Daisy Chain

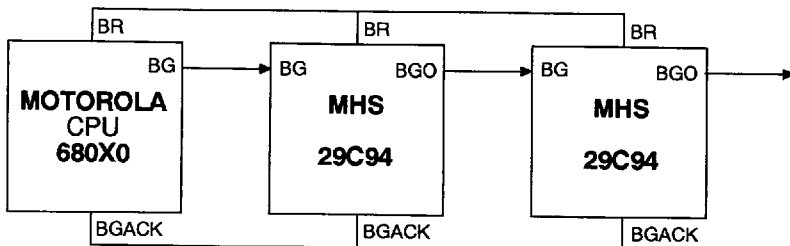

2.5. Interrupt Controller

The interrupt controller generates an interrupt request each time a DMA buffer is closed (end of frame with normal or error status). The CPU identifies the interrupting channel by reading the eight 8-bit interrupt registers (see *INTRQ* registers on chapter 3.5). Purpose of the interrupt request is to re-initialize exhausted buffers by setting up the related DMA descriptors.

When a bit is set in one of the *INTRQ* register, the related *RCTST* and *XCTST* channel status registers shall be read. The *INTRQ* registers are read only type.

Reading one register will automatically reset all 8 bits. However, no interrupt can be missed, because the setting of a bit arriving during a CPU read cycle is delayed and therefore, the register reset after read will not apply to this bit.

The INTERRUPT REQUEST output (pin#67) will be true if at least one bit of any one of the eight *INTRQ* is set.

A flow chart of the interrupt routine is presented on figure 13.

3.0 Register Definitions

All the control registers data are stored into the 29C94 internal RAM, which mapping is shown on table 2. As previously described in FUNCTIONAL

DESCRIPTION, starting on chapter 1.0, one can distinguished two kinds of control registers; Global registers and context registers.

29C94

Organization and definition

3.1. Global Registers

Control of global operating mode requires fourteen 8-bit registers. Only six of them, on addresses 1000_H-1001_H-1002_H-1003_H-100C_H-100D_H, are eventually used to specify operating mode. The other eight are split into two stacks of four 8-bit registers, on

addresses 1004_H-1005_H-1006_H-1007_H and 1008_H-1009_H-100A_H-100B_H, and are used to assert interrupt requests upon buffers switching. Register names and addresses, register status after reset and bit mnemonics are shown below, table 4.

Table 4 : Global Operating Mode Control Registers.

Register		MNEMONICS								Reset State
Name	Addr.	bit 7	bit 6	bit 5	bit 4	bit 3	bit 2	bit 1	bit 0	
MODE	1000 _H	LB	DXC1	DXC0	DPR8	DPX8	DC	T1	MSTR	00 _H
ROFFSET	1001 _H	DPR7	DPR6	DPR5	DPR4	DPR3	DPR2	DPR1	DPR0	00 _H
XOFFSET	1002 _H	DPX7	DPX6	DPX5	DPX4	DPX3	DPX2	DPX1	DPX0	00 _H
GLOBINH	1003 _H	NA	NA	NA	NA	NA	NA	NA	GINH	00 _H
XINTRO	1004 _H	ITX7	ITX6	ITX5	ITX4	ITX3	ITX2	ITX1	ITX0	00 _H
	1005 _H	ITX15	ITX14	ITX13	ITX12	ITX11	ITX10	ITX9	ITX8	00 _H
	1006 _H	ITX23	ITX22	ITX21	ITX20	ITX19	ITX18	ITX17	ITX16	00 _H
	1007 _H	ITX31	ITX30	ITX29	ITX28	ITX27	ITX26	ITX25	ITX24	00 _H
RINTRO	1008 _H	ITR7	ITR6	ITR5	ITR4	ITR3	ITR2	ITR1	ITR0	00 _H
	1009 _H	ITR15	ITR14	ITR13	ITR12	ITR11	ITR10	ITR9	ITR8	00 _H
	100A _H	ITR23	ITR22	ITR21	ITR20	ITR19	ITR18	ITR17	ITR16	00 _H
	100B _H	ITR31	ITR30	ITR29	ITR28	ITR27	ITR26	ITR25	ITR24	00 _H
TESTREG0	100C _H	TST7	TST6	TST5	TST4	TST3	TST2	TST1	TST0	FF _H
TESTREG1	100D _H	NA	NA	NA	NA	NA	NA	NA	TST8	01 _H

Read/Write into Global Registers

CPU intervention, read or write, into the global registers needs three XTAL1 periods. To either read or write into the registers, the host CPU drives a valid address on the system bus (AD 12;0), with CS = 0 (Chip Select). Data bytes are transferred to and from the 29C94 under the host CPU control according the truth table of table 5 below. Both write or read cycles

end with a 29C94 acknowledgement that asserts DTACK=0 in MOTOROLA mode or DTACK=1 in INTEL mode.

Timing diagrams of the read and write operations are shown on chapters 6.3/6.4 (INTEL) and 7.3/7.4 (MOTOROLA).

Table 5 : Write/Read operations on Global Control Registers

Signal Active Levels		MOTOROLA Mode		INTEL Mode	
		Write	Read	Write	Read
MOTOROLA/INTEL MODE ⁽¹⁾	MOT	Vcc	Vcc	Gnd	Gnd
ADDRESS LATCH ENABLE STROBE ⁽²⁾	ALE	Gnd	Gnd	1	1
CHIP SELECT	CS	0	0	0	0
ADDRESS STROBE	AS	0	0	1	0
DATA STROBE	DS	0	0	NA	NA
WRITE STROBE	WS	0	1	0	1

- Notes : 1. The MOT pin (#50) must be definitely tied to VCC in MOTOROLA mode and to ground in INTEL mode.
2. The ALE pin (#29) should be tied to ground in MOTOROLA mode.

Global Register Descriptions & Bit Definitions

3.2. MODE Register - Address 1000_H -

The register specifies the global operating mode of the 29C94 according bit control listed in the truth table 6 below

Table 6 : Bit Functions in MODE Register

Bit	Bit level		
	"1"	"0"	
MSTR	Master mode	Slave mode	
T1	T1/DS1 operating mode	CEPT operating mode	
DC	Double clock	Simple clock	
DPX8	Transmit offset extension bit		
DPR8	Receive offset extension bit		
DXC0 DXC1	DX output (pin # 55) driving mode programming		
	DXC1	DXC0	DX output
	0	0	High impedance
	0	1	Always driving
	1	0	Open collector
	1	1	Not used
LB	Loop back, for test purpose		Normal operating mode

2

When loop back mode is selected all transmit channels are looped back to their corresponding receive channels through the PCM HANDLER. In that operating mode the receive and transmit offset programming as well as byte alignment procedure must be as explained in the FRAME SYNC OFFSET chapter starting on chapter 2.1. Special attention should be devoted to,

- 1 - Set-up the DMA descriptors for both transmit and receive channels on every single or hyper channel.
- 2 - Program *RSPEED/XSPEED* registers of related channels with the same value.

- 3 - Program *RMOD* register, the channel number and *ITVR* bit, on every single and hyperchannel, ending with hyperchannel head as explained on chapter 3.7.
- 4 - Wait for all *ITVR* being set to "1" on every single and hyperchannel.
- 5 - Program *XMOD* register, the channel number and *ITVR* bit, on every single and hyperchannel, ending with hyperchannel head.

After completion of this procedure, the device is fully ready for transmit/receive loop.

3.3. OFFSET Registers – ROFFSET at 1001_H, XOFFSET at 1002_H – TEST REGISTERS – TESTREG0 at 100CH, TESTREG1 at 100DH –

OFFSET REGISTERS and TEST REGISTERS are working in conjunction. Binary count is used. The *TESTREG* specifies the number of time slot (one time slot=eight bit clock) to be used in the selected operating mode (24 T1/DS1, 32 CEPT).

Provided that the 9-bit word TST (8:0) contained in *TESTREG0* and *TESTREG1* registers is as shown in Table 7, then the PCM counters will count accordingly. Otherwise, the PCM counters will count by TST (8:0) + 1.

29C94

Table 7 : PCM Counters and Test Registers programming.

MODE	Binary Value		PCM Counters	
	OF TST (8:0)		Decimal Count	
	Single Clk	Double Clk	Single Clk	Double Clk
CEPT	01111111	11111111	256	512
T1/DS1	01100000	11100001	193	386

Master mode : The 29C94 generates the FSX/FSR frame sync at 8 kHz by using the XCLK and RCLK bit clocks.

The width of FSX/FSR sync pulses is one XCLK/RCLK period. Pulses are triggered when the PCM bit counters reach the value programmed in the offset registers (DPR8 and DPX8 bits are only used in double clock mode).

The 29C94 includes two PCM counters, one for transmitting and one for receiving. The counters are incremented by XCLK (transmit) and RCLK (receive) and thus keep track of time slots and PCM frame sequence. The DPR8/DPX8 extension bit

allows to count up to 512, as necessary in double clock mode with a CEPT frame (for more information see technical note).

Slave mode : The FSR/FSX frame syncs are supplied to the 29C94. They are used to preset the PCM counters with the content of the offset registers. Counters presetting takes place on falling edge of XCLK/RCLK with FSX/FSR high. The frame sync pulse must be one bit clock period wide.

Double clock : This mode relates to GCI standard. For both XCLK and RCLK, two bit clock are used per single bit frame.

3.4. GLOBINH Register – Address 1003_H –

Applying a RESET to the 29C94 (see table 1 RESET logic levels) results in a global inhibit of the device.

After reset the HDLC PROCESSOR is idle and DX output is in high impedance state. The global control registers status is shown on table 4 immediately after reset. However, reset applies only to the global registers and not to the context ones. Caution must be exercised for a proper initialisation of the whole device.

First, it is necessary to let GINH (bit 0 of GLOBINH register) be at low level for a least 2 full PCM frames with valid XCLK and RCLK. It is also mandatory to have the channels control registers set up by the host CPU before letting GINH be at logical "1". Not following this procedure would induce 29C94 erratic behaviour.

3.5. XINTRQ – Address 1004_H thru 1007_H – RINTRQ – Address 1008_H thru 100B_H –

These two sets of registers are used to signal that a data frame completion and therefore a buffer switching, has occurred on a receive or transmit channel. Upon data frame completion, a bit is automatically set to "1" in the related register, at the location that points to the channel number.

Any bit at "1" in the set of registers asserts the INTREQ output high (pin # 67), thus calling for the host CPU to read and memorize all eighth interrupt registers. The host will then read the status registers of the interrupting channel(s). The XINTRQ/RINTRQ registers are reset to zero when read by the cpu. Fig. 13 illustrates an interrupt routine.

Figure 13. Interrupt Routine.

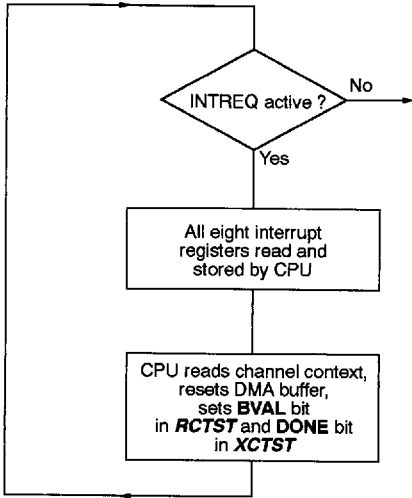

Initialization

Upon power-up the 29C94 must be resetted. This is performed by asserting the RESET signal for, at least, two PCM frame periods with valid XCLK and RCLK bit clock. All global registers are set in reset values as indicated in table 4. The 29C94 is then in slave, single clock CEPT operating mode. The whole chip is inhibited, and frame offset is zero. However, all the context registers are still in undefined states and should be set up by the host CPU as shown in the following flow chart. Literate explanations of the procedure may be found on chapter 3.7 where an hyperchannel setting procedure is described.

A diagram of an initialization procedure example in Figure 14.

Figure 14. Example of initialization procedure.

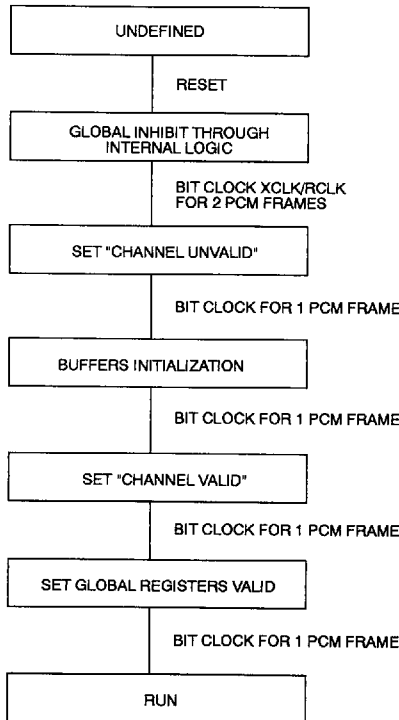

29C94

3.6. Channel Context Register

Each PCM frame time slot has its own set of context registers. The registers are stacked into a double port RAM. An 8-bit wide port is used for CPU communication (Read/Write operations). The other port is 16-bit wide and is used in the successive operations of context restore-execute-save.

The 8-bit wide port to the outside world is sufficient because performances of the 29C94 is widely

self-supported, CPU intervention is not frequent. The 16-bit port is the gateway to the 29C94 internal bus. It needs to be wider because there are 128 bytes of context data to switch time slot after time slot.

The 32 CEPT receive contexts (24 in T1/DS1) are stored on decimal addresses 0H through 7FFH, while the transmit contexts are stored from 800H through FFFH (see table 2, internal RAM mapping).

Context Registers Description & Bit Definition

Each time slot is associated with a set of receive and transmit context registers that define reciprocally the receive and transmit channel. Tables 8 and 9 thereafter, describe the details of receive and transmit context for time slot 0. These sets of registers are repeated for all 32 time slots as previously explained, that is to say a total of 64 single channels (32 receive + 32 transmit).

It should be noticed that the organization of the channel context is split in two parts. The first part,

referred as the HDLC descriptor, is related to transmit/receive data processing for that time slot. It contains various operating parameters and data which purposes are defined further on.

The other part of the context data is called the DMA descriptor ; It contains word count, buffer address and DMA status. That second part of the channel context is replicated eight times, once per buffer, since for each channel is allocated eight chained buffers.

Table 8 : Time Slot 0, Receive Context Registers.

MNEMONICS								Context Register	
bit 7	bit 6	bit 5	bit 4	bit 3	bit 2	bit 1	bit 0	Name	address
Channel Number (bit "log4" thru "log0")					N.U ⁽¹⁾	XPRT	ITV	RMOD	0000 _H
Rate adaptor – Fill Mask. (bit "RSP7" thru "RSP0")								RSPEED	0001 _H
Current Buffer number			FTR	DMAD	Data Frame Status			RSTAT1	0002 _H
Flac	N.U ⁽¹⁾	N.U(1)	State Mac		Bit count			RSTAT2	0003 _H
Shift Register 3								Shift 3	0004 _H
Shift Register 2								Shift 2	0005 _H
Shift Register 1								Shift 1	0006 _H
DATA								FIFO	0007 _H
Frame check sequence – low byte –								CRCL	0008 _H
Frame check sequence – high byte –								CRCH	0009 _H
DMA Descriptor									
Buffer 0. – Word count – low byte –								WCL ₀	000A _H
Buffer 0. – Word count – high byte –								WCH ₀	000B _H
Buffer 0. – Current Address pointer – low byte –								ACTL ₀	000C _H
Buffer 0. Current Address pointer – high byte –								ACTH ₀	000D _H
Lsyn	Ftr	Tout	Udf	Nba	Abrt	CRCE	Done	RCTST	000E _H
Buffer 0.			Page Address					SEGMT ₀	000F _H
Buffer 1.		Word count Address pointer			0010 _H thru 0015 _H	
Buffer 1.	 Page, Status							
Buffer 2.		Word count Address pointer			0016 _H thru 001B _H	
Buffer 2.	 Page, Status							
Buffer 3.		Word count Address pointer			001C _H thru 0021 _H	
Buffer 3.	 Page							
Buffer 4.		Word count Address pointer			0022 _H thru 0027 _H	
Buffer 4.	 Page, Status							
Buffer 5.		Word count Address pointer			0028 _H thru 002D _H	
Buffer 5.	 Page, Status							
Buffer 6.		Word count Address pointer			002E _H thru 0033 _H	
Buffer 6.	 Page, Status							
Buffer 7.		Word count Address pointer			0034 _H thru 0039 _H	
Buffer 7.	 Page, Status							

Note : 1. N.U = Not Used.

2

29C94

Table 9 : Time Slot 0, Receive Context Registers.

		MNEMONICS							Context Register		
		bit 7	bit 6	bit 5	bit 4	bit 3	bit 2	bit 1	bit 0	Name	address
H D L C		Channel Number (bit "log4" thru "log0")					FLG	XPRT	ITVX	XMOD	0800H
		Rate adaptor - Fill Mask. (bit "XSP7" thru "RSP0")							XSPED	0801H	
		Current Buffer number			FTR	DMAD	Data Frame Status			XSTAT1	0802H
		ITac	N.U ⁽¹⁾	Transmit State Mac			Bit count			XSTAT2	0803H
		Shift Register								Shift 1	0804H
		N.U ⁽¹⁾	FIFO CONTROL			TAG 2		TAG 1		TAG	0805H
		FIFO 1								FIFO1	0806H
		FIFO 2								FIFO2	0807H
		Frame check sequence - low byte -								CRCL	0808H
		Frame check sequence - high byte -								CRCH	0809H
Transmit DMA Descriptor											
D E S C R I P T O R		Buffer 0. - Word count - low byte -							WCL ₀	080AH	
		Buffer 0. - Word count - high byte -							WCH ₀	080BH	
		Buffer 0. - Current Address pointer - low byte -							ACTL ₀	080CH	
		Buffer 0. Current Address pointer - high byte -							ACTH ₀	080DH	
		N.U ⁽¹⁾	N.U ⁽¹⁾	N.U ⁽¹⁾	N.U ⁽¹⁾	N.U ⁽¹⁾	TOUT	EOF	BVAL	XCTST	080EH
		Buffer 0.			Page Address				SEGMT ₀	080FH	
		Buffer 1.	Word count Address pointer Page, Status		0810H thru 0815H
		Buffer 2.	Word count Address pointer Page, Status		0816H thru 081BH
		Buffer 3.	Word count Address pointer Page, Status		081CH thru 0821H
		Buffer 4.	Word count Address pointer Page, Status		0822H thru 0827H
		Buffer 5.	Word count Address pointer Page, Status		0828H thru 082DH
		Buffer 6.	Word count Address pointer Page, Status		082EH thru 0833H
		Buffer 7.	Word count Address pointer Page, Status		0834H thru 0839H

Note : 1. N.U = Not Used.

DLC Descriptor

Only the **RMOD/XMOD** and **RSPEED/XSPEED** registers are automatically maintained by the internal logic of the 29C94. Writing into them would induce erratic behaviour of the device.

- 3.7. RMOD REGISTERS** : Add : 000_H + N⁽¹⁾ × (40_H).
XMOD REGISTERS : Add : 800_H + N⁽¹⁾ × (40_H).

The registers control the HDLC PROCESSOR logic according the truth tables below.

Receive Channel

Table 10 : XMOD Register Truth Table.

Bit MNEMO	Bit level	
ITVR	Channel Enable	Channel disable
XPRT	Clear Channel mode	HDLC format
log ₀ thru log ₄	Binary Channel Number	

Transmit Channel

Table 11 : RMOD Register Truth Table.

Bit MNEMO	Bit level	
ITVX	Channel Enable	Channel disable
XPRT	Clear Channel mode	HDLC format
FLG	Flag sharing mode	Flag not shared
log ₀ thru log ₄	Binary Channel Number	

Hyperchannel

The log₀ through log₄ bits specify the channel number.

- When this binary channel number is equal to the current time slot number maintained in the PCM counter, then the current time slot is a single channel or the head of an hyperchannel.
- When the channel number (log₀ through log₄ bits) is not equal to the current time slot number, then that time slot is part of an hyper channel and is concatenated with the time slot defined by log₀ through log₄.

Notes : 1. N equal time slot number,

29C94

Particular attention should be paid to the fact that all time slots pertaining to an hyperchannel must have identical **RMOD** and **RSPEED** register contents on the receive channel as well as identical **XMOD** and **XSPEED** contents on the transmit side.

The DMA descriptor of an hyperchannel head is shared by all time slots concatenated to the channel head.

Procedure to set-up a receive hyperchannel is :

1. Reset to 0 the ITVR bit of all time slots to be concatenated in the hyperchannel.
2. Set-up the DMA descriptor of hyperchannel head.
3. Successively, **ending with the hyperchannel head**, write identical content in **RMOD** and **RSPEED** registers of the related time slots, setting ITVR = 1.

The same procedure applies to set a transmit hyperchannel, except that the involved registers are **XMOD** and **XSPEED**.

Conversely, the procedure to de-activate a receive hyperchannel is :

1. Reset to 0 the ITVR bit of hyperchannel head.
2. Wait for ITVR being copied into ITac of RSTAT register of the hyperchannel head.
3. Update channels configuration.

Again, identical procedure applies for a transmit hyperchannel, except that it is the transmit context registers that are involved.

3.8. RSPEED REGISTERS. Add : $001_H + N^{(1)} \times (40_H)$.
XSPEED REGISTERS. Add : $801_H + N^{(1)} \times (40_H)$.

Those are the fill/mask registers used for rate adaptation as explained in fig 9A and 9B.

Other HDLC Descriptor registers

All other HDLC registers may be read, but should not be written into, which would cause unpredictable operations. Of particular importance is the ITac bit (bit 7) of, respectively, the **RSTAT2** and **XSTAT2** registers. Each time a time slot context is restored, the time slot enable bit (ITVR/ITVX) is copied into ITac. Precisely, ITVR is copied into ITac of **RSTAT2** and ITVX is copied into ITac of **XSTAT2**, with exception

for hyperchannel. ITac may be regarded as the acknowledge bit of the time slot enable. A safe procedure to change a channel operating mode is shown in table 12.

The following registers are described for information only and users should not temper with them.

Table 12 : Operating Mode Modification Procedure.

	Transmit	Receive
1	Reset ITVX to 0	Reset ITVR to 0
2	Wait for ITac = 0	Wait for ITac = 0
3	Modify as required XMOD, XSPEED, DMA descriptors,	Modify as required RMOD, XSPEED, DMA descriptors
4	Set ITVX to 1.	Set ITVR to 1.

Notes : 1. N equal time slot number,

3.9. RSTAT1 REGISTERS. Add : $002_H + N^{(1)} \times (40_H)$.
XSTAT1 REGISTERS. Add : $802_H + N^{(1)} \times (40_H)$.

Table 13 : RSTAT1/XSTAT1 bit definitions

Bit	MNEMONIC	Receive Functions		Transmit Functions	
		Frame Status + Data	Result	Frame Status	Result
0 1 2	Data Frame status	101 (5 _H) 0 110 (6 _H) 0 110 (6 _H) 1	Delete Zero Flag Abort	101 (5 _H)	Insert one "ZERO" if currently transmitting data or CRC.
3	DMAD	1 = DMA request upon next occurrence of logical channel.		1 = DMA request upon next occurrence of logical channel	
4	FTR	1 = End of frame on next occurrence of logical channel.		1 = End of frame on next occurrence of logical channel.	
5 6 7	INDEX	Binary number of buffer currently being used.		Binary number of buffer currently being used.	

The INDEX bits are automatically reset to zero when a channel of hyperchannel is disabled. When the channel will be again enabled, the index will point to the first descriptor.

3.10. RSTAT2 REGISTERS. Add : $003_H + N^{(1)} \times (40_H)$.
XSTAT2 REGISTERS. Add : $803_H + N^{(1)} \times (40_H)$.

Table 14 : RSTAT2/XSTAT2 Bit Definition

Bit	MNEMONIC	Receive Functions		Bit	MNEMONIC	Transmit Functions	
0 1 2	BitCount	Binary count of received bits on current byte $0 < N < 7$		0 1 2	BitCount	Binary count of transmitted bits on current byte $0 < N < 7$	
3 4	Stat Mac	Internal logic status		3 4	Stat Mac	Internal logic status	
		4 . 3	Status			5.4.3.	Status
3 4		0 . 0 0 . 1 1 . 0 1 . 1	Idle Flag received Data ; DMA not author. Data ; DMA authorized	3 4		0.0.0 0.1.0 0.1.1 1.0.0 1.0.1 1.1.0 0.0.1	Opening flag Data being transmitted Data being transmitted CRC being transmitted CRC being transmitted Closing flag Abort
5		Not used		5		Not used	
6		Not used		6		Not used	
7	ITac	Copy/acknowledge of ITVR (Bit 0 of RMOD registers)		7	ITac	Copy/acknowledge of ITVR (Bit 0 of XMOD registers)	

Notes : 1. N equal time slot number.

29C94

SHIFT3 REGISTERS. Add : $004_H + N^{(1)} \times (40_H)$.

Receive channel. *SHIFT3* contains a received byte that will be later on transferred to the DMA CONTROLLER to be eventually stored into a buffer.

SHIFT REGISTERS. Add : $804_H + N^{(1)} \times (40_H)$.

Transmit channel. Contains a data byte that is being serialized for transmission.

SHIFT2 REGISTERS. Add : $005_H + N^{(1)} \times (40_H)$.

Receive channel. Contains a data byte that will be later moved to *SHIFT3* and thus eventually stored into a buffer.

TAG REGISTERS. Add : $805_H + N^{(1)} \times (40_H)$.

Transmit channel. *TAG* contains three sets of control bits. The first two sets, bit 0 through 3, are referred as tag1 and tag2. They are used as a qualifier for data transfer from the DMA CONTROLLER to HDLC PROCESSOR as shown in table 15. *TAG1* qualifies the byte in *FIFO1*, and *TAG2* qualifies the byte in *FIFO2*.

The third set of control bits extends from bit 4 to bit 6. It is referred as FIFO control and performs a continuous data supply into the transmit pipeline.

SHIFT1 REGISTERS. Add : $006_H + N^{(1)} \times (40_H)$.

Receive channel. Contains a data byte that will be later moved to *SHIFT2* and thus stored eventually into a buffer.

Table 15 : Tag definitions.

TAG	Definitions
00	Invalid data byte resulting from time out.
01	Valid data
10	Last byte of data frame

FIFO1 REGISTERS. Add : $806_H + N^{(1)} \times (40_H)$.

Transmit channel. One of the slots of the transmit pipeline.

FIFO REGISTERS. Add : $007_H + N^{(1)} \times (40_H)$.

Receive channel. One of the slots of receive pipeline.

FIFO2 REGISTERS. Add : $807_H + N^{(1)} \times (40_H)$.

Transmit channel. One of the slots of the transmit pipeline.

RCRCL REGISTERS. Add : $008_H + N^{(1)} \times (40_H)$.

RCRCH REGISTERS. Add : $009_H + N^{(1)} \times (40_H)$.

Receive channel. Those two registers contain the current CRC computation related to the data frame being received. *RCRCL* is CRC low byte, and *RCRCH* the high one. They are compared to the CRC that is received at frame end, just before the closing flag.

XCRCCL REGISTERS. Add : $808_H + N^{(1)} \times (40_H)$.

XCRCCH REGISTERS. Add : $809_H + N^{(1)} \times (40_H)$.

Transmit channel. Those two registers contains the current CRC computation in relation with the data frame being transmitted. *XCRCCL* is CRC low byte, and *XCRCCH* the high one. They are transmitted on the ISDN line, MSB first, after the last data byte, just before the closing flag.

3.11. DMA Descriptors

Both transmit and receive DMA descriptors have the same organization, except for the *RSTAT* and *XSTAT* status registers. Each channel has eight descriptors as shown on tables 8 and 9, context mapping.

RWCL REGISTERS. Add :

$$00A_H + N^{(1)} \times (40_H + I^{(2)} \times 6_H)$$

RWCH REGISTERS. Add :

$$00B_H + N^{(1)} \times (40_H + I^{(2)} \times 6_H)$$

Receive channel. Contain the low and high bytes of the 16-bit word count. This define the buffer capacity. The word count is decremented by one each time a data byte is transferred into the buffer. When word count reaches zero, the buffer index in *RSTAT1* is incremented by one.

XWCL REGISTERS. Add :

$$80A_H + N^{(1)} \times (40_H + I^{(2)} \times 6_H)$$

XWCH REGISTERS. Add :

$$80B_H + N^{(1)} \times (40_H + I^{(2)} \times 6_H)$$

Transmit channel. Same as *RWCL* and *RWCH*, except that word count is decremented after a data byte was fetched into the buffer.

Notes : 1. N equal time slot number.

2. I equal buffer index number.

RACTL REGISTERS. Add :
 $00C_H + N^{(1)} \times (40_H + I^{(2)} \times 6_H)$.

RACTH REGISTERS. Add :
 $00D_H + N^{(1)} \times (40_H + I^{(2)} \times 6_H)$.

Receive channel. Contain the first 16 bits of the 24-bit buffer address. Upon initialization the host CPU sets up the starting address. Then, each time a byte is transferred into the buffer, the address is incremented by one.

XACTL REGISTERS. Add :
 $80C_H + N^{(1)} \times (40_H + I^{(2)} \times 6_H)$.

XACTH REGISTERS. Add :
 $80D_H + N^{(1)} \times (40_H + I^{(2)} \times 6_H)$.

Transmit channel. Same as **RACTL** and **RACTH**, except that address is incremented after a data fetching.

RSEGMT REGISTERS. Add :
 $00F_H + N^{(1)} \times (40_H + I^{(2)} \times 6_H)$.

Receive channel. Contains the highest 8 bits of the 24 bit buffer address. This is a fixed number, set by the host CPU.

XSEGMT REGISTERS. Add :
 $80F_H + N^{(1)} \times (40_H + I^{(2)} \times 6_H)$.

Transmit channel. Same as **RSEGMT**.

RCTST REGISTERS. Add :
 $00E_H + N^{(1)} \times (40_H + I^{(2)} \times 6_H)$.

Receive channel. DMA descriptor status register.

This is the status register of the receive DMA descriptor. **DONE** is a semaphore bit that is cleared to zero by users to point out that word count (**RWCL/RWCH**), and address (**RACTL/RACTH/RSEGMT**) are valid. Then incoming data stream may be stored into that buffer.

When the buffer index points to a DMA descriptor where **DONE** is already set to "1", the buffer is not written nor is the **RCTST** register. This state is referred as an overload state. However, since the previous buffer closing has triggered an interrupt request, users is warned that the buffers must be re-initialized. To recover from the overload state, users may :

1. Read the **INDEX** in **RSTAT1**, and re-initialize that descriptor where the DMA CONTROLLER is waiting, or
2.
 - Clear **ITVR** into **RMOD** to inhibit receiving data
 - Wait for **ITac** acknowledge (read **RSTAT2**)
 - Re-initialise the entire set of descriptors
 - Set **ITVR** back to "1"

2

Notes : 1. N equal time slot number.
 2. I equal buffer index number.

29C94

In procedure 2, the buffer index is reset to zero.

To update a descriptor, it is recommended to successively set *RWCL/RWCH* (word count), *RACTL/*

RACTH/RSEGMT (address) and to end up with *RCTST* programming.

Table 16 : Receive Status, DMA Descriptor.

Bit #	Bit MNEMO	BIT LEVEL	
		"1"	"0"
0	DONE	Buffer invalid	Buffer valid
1	CRCE	CRC error/end of frame	CRC valid/end of frame
2	ABRT	Abort recognized	Valid frame
3	NBA	Bit alignment error	Byte alignment valid
4	UDF	Frames than buffer	Frame correct
5	TOUT	Time out	
6	FTR	End of frame	
7	LSYN	Lost of sync	

XCTST REGISTERS. Add : $80E_H + N^{(1)} \times (40_H + I^{(2)} \times 6_H)$.

Transmit channel. DMA descriptor status register.

This is the status register of the transmit DMA descriptor. *BVAL* is a handshake bit that is preset to one by users to point out that word count (*XWCL/XWCH*), and address (*XACTL/XACTH/XSEGMT*) are valid. When word count reaches zero, the DMA CONTROLLER clears *BVAL* and sets *EOF* to "1". If a time out occurs in a DMA cycle, the DMA CONTROLLER also clears *BVAL* and sets *EOF* and *TOUT* to "1". In that case an ABORT code is transmitted when operating in HDLC mode.

If *BVAL* is at level zero, the DMA CONTROLLER waits until it is reset to "1", buffer index is not incremented, flags are transmitted in HDLC mode and "ONES" in clear channel mode.

It is recommended to update a DMA descriptor by successively programming word count, address and then *XCTST* register. It is mandatory to reset this later register to 01H to clear any previous *TOUT* and *EOF*.

Table 17 : Transmit Status, DMA Descriptor.

Bit #	Bit MNEMO	Bit Level	
		"1"	"0"
0	BVAL	Buffer valid	Buffer invalid
1	EOF	End of frame	
2	TOUT	Time out	
3	N.U		Not used
4	N.U		Not used
5	N.U		Not used
6	N.U		Not used
7	N.U		Not used

Notes : 1. N equal time slot number,
2. I equal buffer index number.

4.0 Electrical Characteristics

Absolute Maximum Ratings

VCC to GND	-0.5V to +7V
Input/Output voltage	-0.3V to VCC + 0.3V
Storage temperature	-65 to 150°C

Operating Conditions

Voltage range (VCC)	4.5 to 5.5V
Temperature range	0 to 70°C

DC Electrical Characteristics

2

Parameter	Conditions	Min	Max	Unit
Low level input voltage VIL	I= 5uA (except XTAL1)		0.8	Volt
High level input voltage VIH	I= 5uA (except XTAL1)	2.2		Volt
Low level input voltage VIL	I= 5uA (for XTAL1)		1.5	Volt
High level input voltage VIH	I= 5uA (for XTAL1)	3.5		Volt
Input leakage current			10	uA
3 STATE output leakage current			10	uA
Low level output voltage VOL	I= - 6.4mA for AD and DA buses, AS, ALE, WR, DTACK, BR, BGO, BGACK, INTREQ I= - 12.8mA for FSX, FSR DX, INHIBX, CLKOUT		0.4	Volt
High level output voltage VOH	I= 16mA for AD and DA buses, AS, ALE, WR, DTACK, BGO, BGACK, INTREQ I= 3.2mA for FSX, FSR, DX, INHIBX, CLKOUT	2.4		Volt
Standby current	VCC= 5V		200uA	
Operating current	VCC= 5V, 33MHZ clock with internal OSC 150pF load on all output except CLKOUT 50pF		100mA	

BR output is an open collector.

DX output may be configured as 3-state, open collector always driving.

29C94

5.0 AC Electrical Characteristics

PCM Interface

VCC = 5 V ± 10 %, Temperature = 0 to 70°C
 150 pF Load on all Outputs except CLKOUT (50 pF)

NAME	DESCRIPTION	MIN ns	MAX ns	NOTE
tdf	Delay XCLK to FSX, RCLK to FSR		25	
tdx	Delay XCLK to DX		25	
tsf	Setup FSX to XCLK, FSR to RCLK	6		
thf	Hold FSX to XCLK, FSR to RCLK	4		
tdzi	Delay XCLK to INHIBX		25	
tzdx	Delay XCLK to DX driving		25	note1
tdxz	Delay XCLK to DX float		25	note1
tsr	Set-up DR to RCLK	25		
thr	Hold DR to RCLK	25		

Note : 1. Applicable when DX output is programmed in either tri-state or open collector mode.

Internal Oscillator Schematic

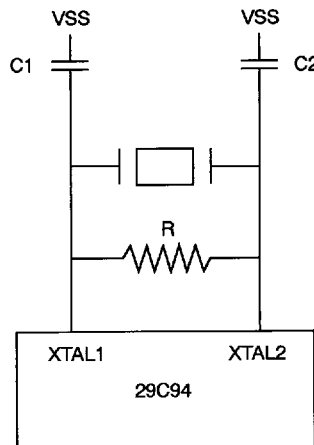

Typical value : R = 4.7 Mohm, C1 = 22 pF, C2 = 33 pF
 When using an external clock XTAL is the clock input.

5.1. Transmit Simple Clock Master Mode

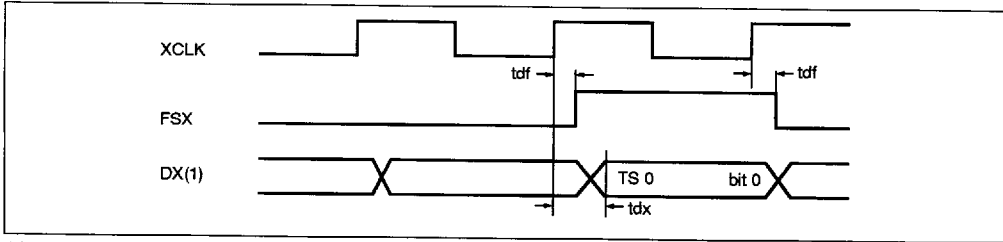

(1) assuming TRANSMIT offset is = OAH

(2) assuming TRANSMIT offset is = 14H

5.2. Transmit Double Clock Master Mode

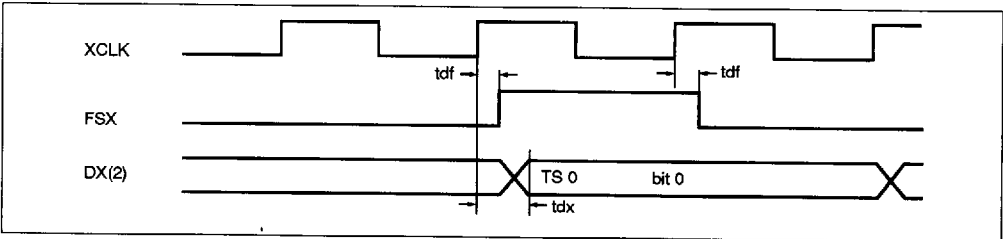

2

5.3. Transmit Simple Clock Slave Mode

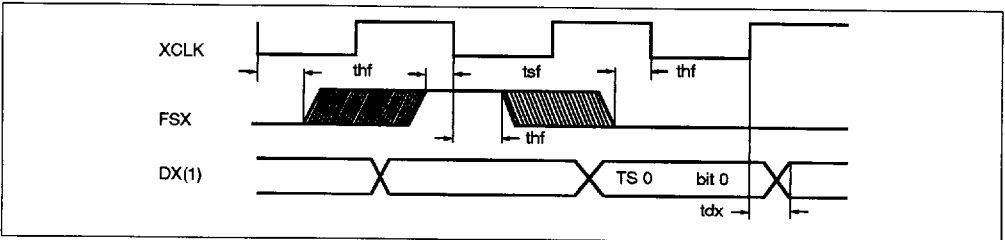

5.4. Transmit Double Clock Slave Mode

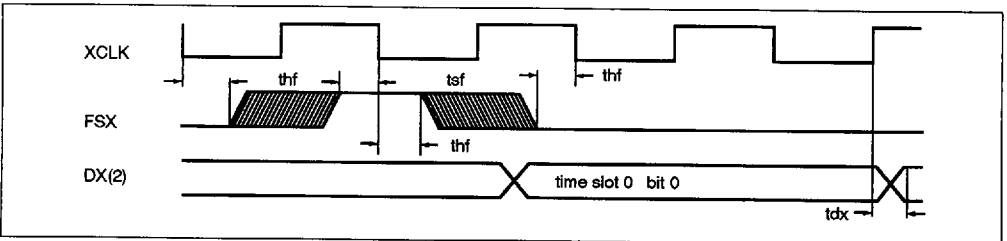

(1) assuming TRANSMIT offset is = OAH

(2) assuming TRANSMIT offset is = 14H

29C94

5.5. Transmit INHIBX Timing (In Master Simple Clock CEPT Mode)

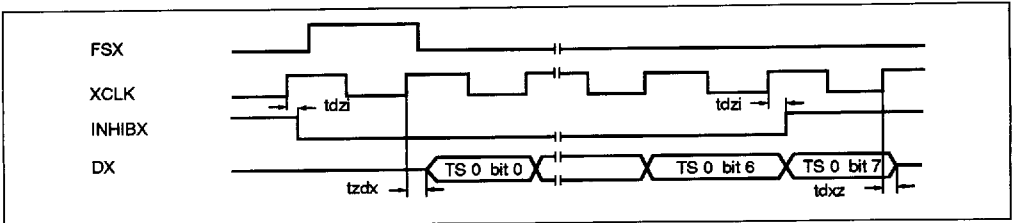

CONDITIONS

- TIME SLOT 0 VALID WITH FULL B CHANNEL (x s p = F F H)
- TIME SLOT 1 AND TIME SLOT 31 NON VALID (I T V X = 0)
- TRANSMIT : Offset = OAH
- DX OUTPUT = TRISTATE

5.6. Receive Simple Clock Master Mode

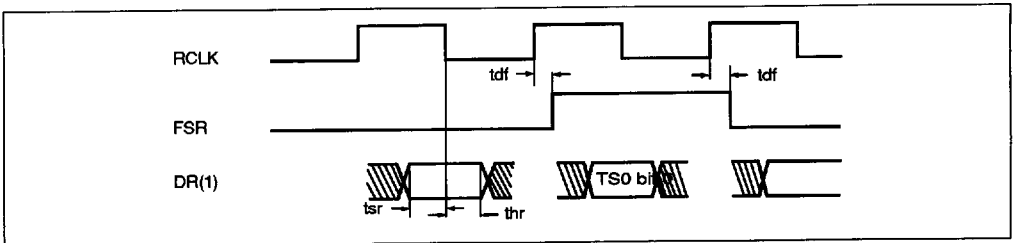

5.7. Receive Double Clock Master Mode

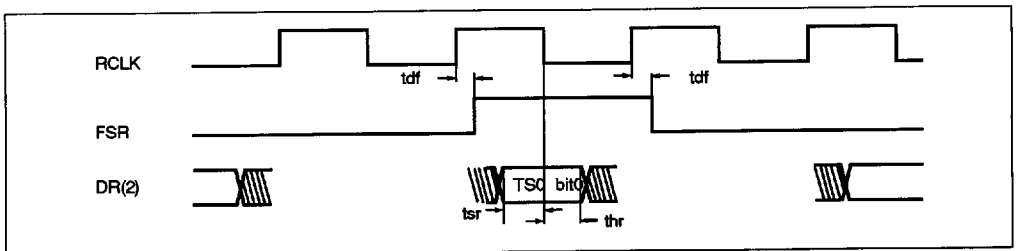

5.8. Receive Simple Clock Master Mode

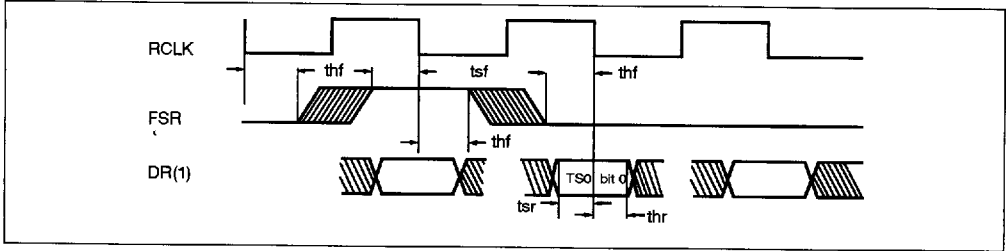

5.9. Receive Double Clock Slave Mode

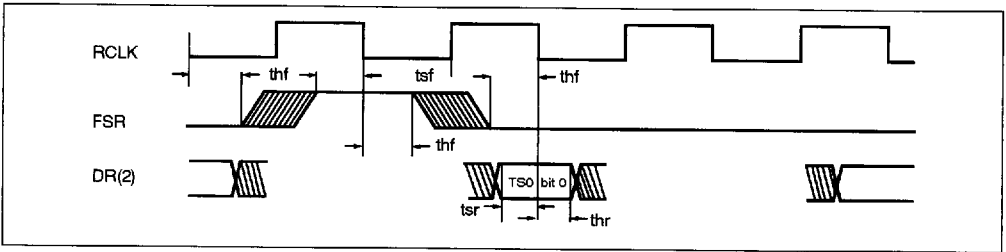

(1) assuming receive offset = 08H

(2) assuming receive offset = 10H

Detail TI/DSI Mode

5.10. Transmit Simple Clock Master Mode

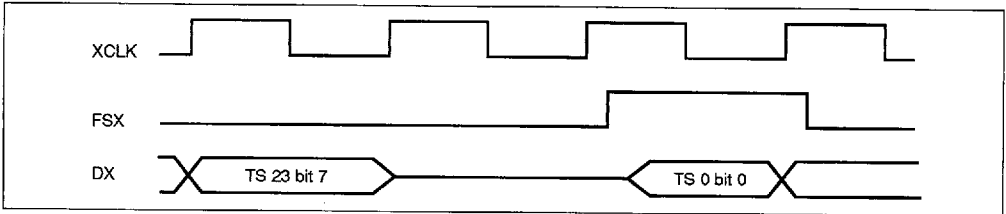

5.11. Receive Simple Clock Master Mode

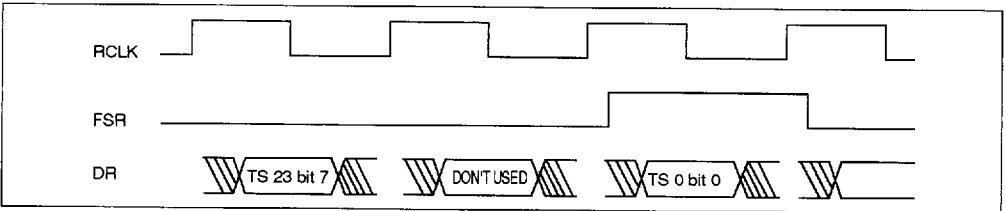

CONDITIONS

- DX OUTPUT = TRISTATE
- Xoffset = 0AH
- Roffset = 08H

29C94

6.0 System Bus Interface

Intel CPU Driving System Bus

VCC = 5 V ± 10 %, Temperature = 0 to 70°C
 150 pF Load on all Outputs except CLKOUT (50 pF)

Name	Description	Min ns	Typ ns	Max ns	Note
clkmin	XTAL clock period	30			
t _{wh}	XTAL high pulse width	12			
t _{wl}	XTAL low pulse width	12			
t _{wale}	ALE high pulse width	15	5		
t _{sa}	setup address to ALE	2			
t _{ha}	hold address to ALE	8			
t _{dcs}	delay ALE to AS/WR/CS	0			
t _{sup}	setup AS/WR/CS to XTAL1	0			note 4
t _{zd}	delay CS to DTACK driving			12	
t _{dd}	delay AS/WR to DTACK			10	
t _{ddt}	delay XTAL edge to DTACK			34	
t _{ddtr}	delay XTAL edge to DTACK			24	note 3
t _{dz}	delay CS to DTACK floatting			20	
t _{sdata}	setup DATA to DTACK	45			note 2
t _{hdata}	hold DATA to DTACK	-15			
t _{sdatar}	setup DATA to DTACK	29			note 3
t _{hdatar}	hold DATA to DTACK	-8			note 3
t _{cyw}	internal write cycle time	2/3 tclk	2/3 tclk	2/3 tclk	note 2
t _{cyr}	internal read cycle time	2/3 tclk	2/3 tclk	2/3 tclk	note 2
t _{za}	delay AS to DATA driving			14	
t _{az}	delay AS to DATA floatting			22	
t _{xd}	delay XTAL1 to data valid			62	
t _{sdt}	setup DATA to DTACK				tclk + tddt - txd
t _{sdr}	setup DATA to DTACK	6			note 3
t _{hds}	hold DATA to AS	6			

- Notes :
- AS, WR, CS may be asynchronous with respect to XTAL1, however "t_{sup}" setup time to the following XTAL1 rising edge must be res to insure that this rising edge will trig the internal R/W cycle overwize, one additionnal tclk will be added to thz R/W cycltime ti.
 - As the internal RAM uses 2 XTAL periods for internal R/W cycle, 2 or 3 XTAL periods are necessary from AS/WR resynchronized falling edge to internal cycle completion (DTACK rising).
 - Register access only.
 Remark : It is possible to maintain ALE = 1 (no address latch) but in that case, address should be valid during the entire I/O cycle. Setup address to CS falling = t_{sa} + t_{dcs}, hold time address to CS rising = 0 ns.
 - Care should be taken on ALE generation.

6.1. INTEL Mode

Memory Read

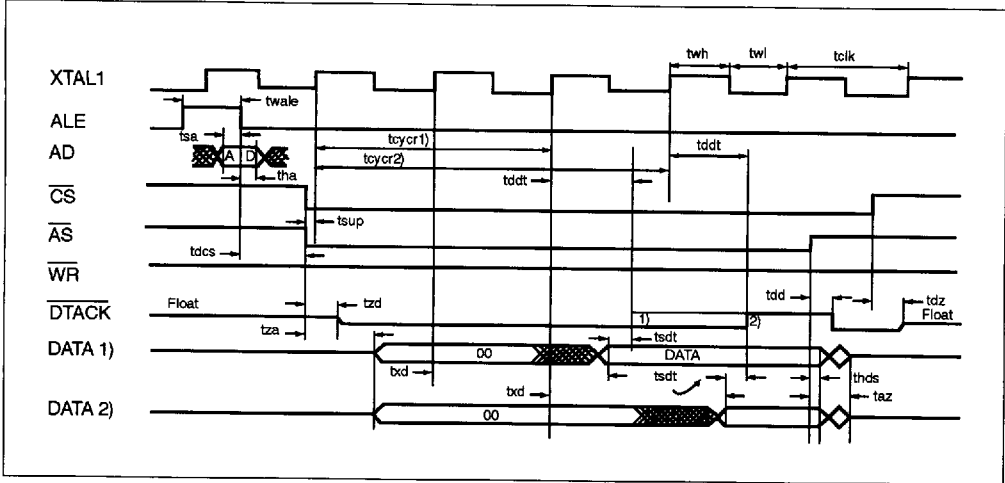

- 1) Shortest cycle
- 2) Longest cycle

6.2. INTEL Mode

Memory Write

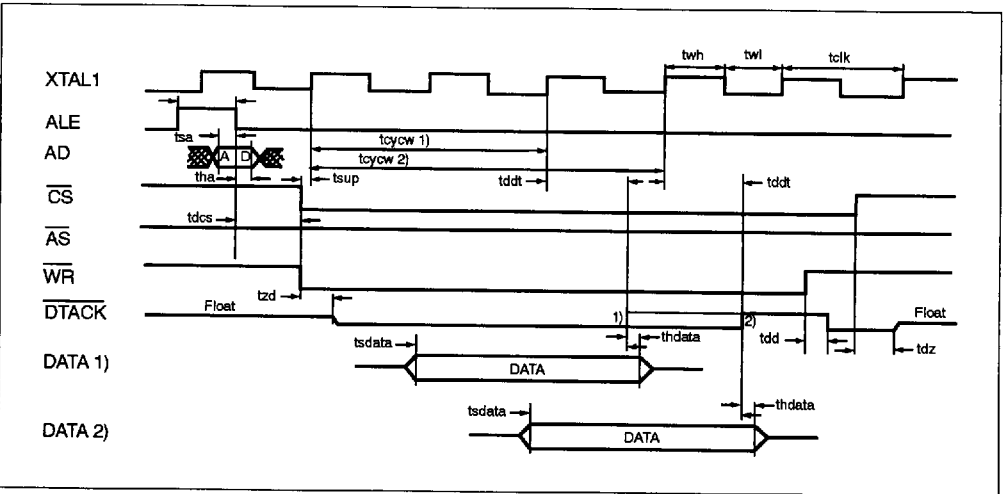

- 1) Shortest cycle
- 2) Longest cycle

29C94

6.3. INTEL Mode

Register Write

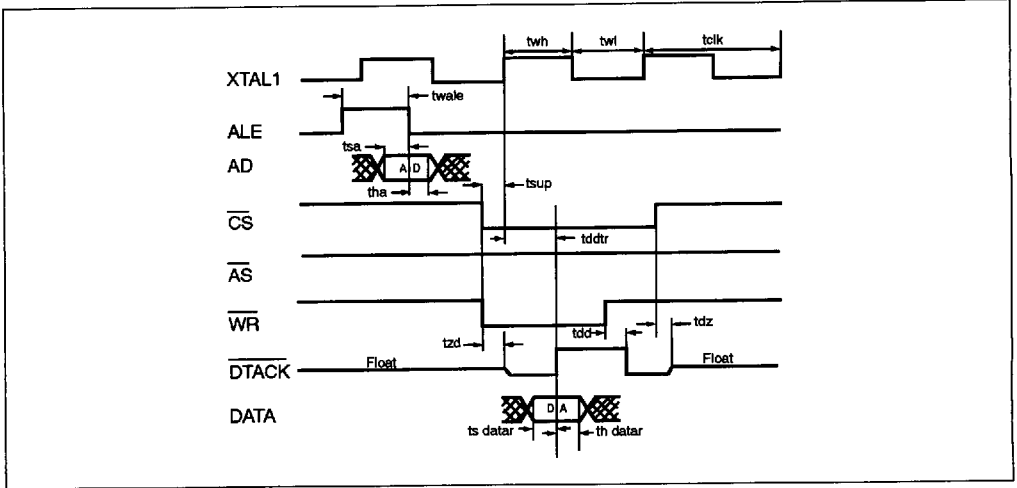

6.4. INTEL Mode

Register Read

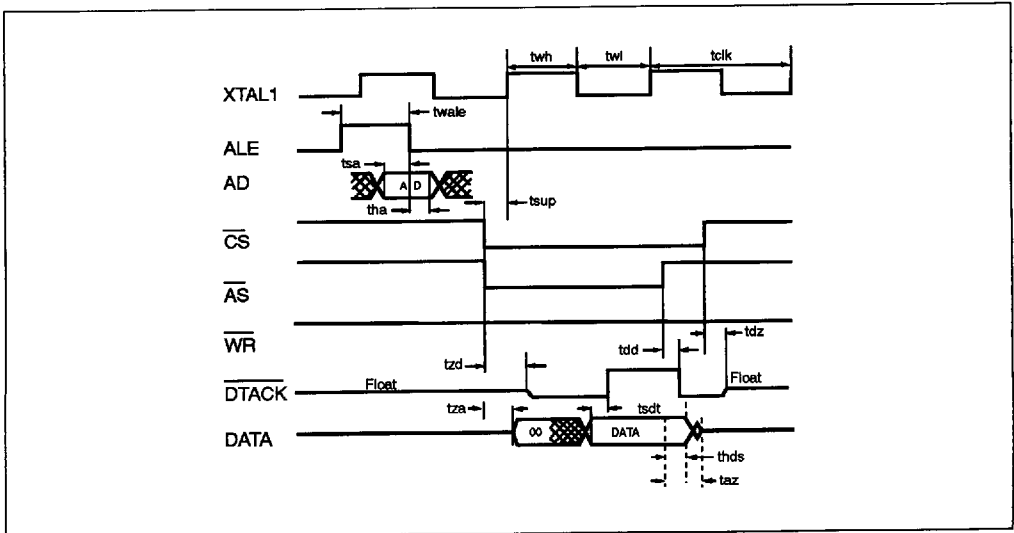

6.5. INTEL CPU DMA Cycle

VCC = 5 V ± 10 %, Temperature = 0 to 70 °C,
150 pF Load on all Outputs except CLKOUT (50 pF)

Name	Description	Min ns	Typ ns	Max ns	Note
t _{br}	Delay XTAL1 to BR			30	
t _{sbg}	Set-up BG to XTAL1	0			
t _{zdc}	Delay XTAL1 to Bus control driving (AS, WR, ALE)			27	
t _{zdad}	Delay XTAL1 to Add bus driving			38	
t _{vdad}	Delay XTAL1 to Add bus valid			39	
t _{zdda}	Delay XTAL1 to Data bus driv.			47	
t _{vdada}	Delay XTAL1 to Data bus valid			48	
t _{dalc}	Delay XTAL1 to ALE			27	
t _{dwrld}	Delay XTAL1 to WR/AS			29	
t _{dcz}	Delay XTAL1 to bus control float (AS, WR, ALE)			45	
t _{dadz}	Delay XTAL1 to Add. bus float			52	
t _{ddaz}	Delay XTAL1 to Data bus float			45	
t _{sda}	Set-up DTACK to XTAL1	0			
t _{hda}	Hold DTACK to XTAL1	17			
t _{sda}	Set-up Data bus to XTAL1	2			
t _{hda}	Hold Data bus to AS	-20			note 1
t _{bga}	Delay BGACK to BR (DAISY CHAIN)			15	
t _{bgo}	Delay XTAL1 to BGO			24	
t _{dbgo}	Delay BG to BGO			10	

- Notes :
1. t_{hda} shall be referenced to the XTAL1 falling edge that sample DT with the same figure.
Remarks : Bus mastership is always returned to the CPU after a successful DAISY chained DMA cycle, even if an internal DMA request is issued before DAISY CHAIN cycle completion.
2 DMA cycle Read then Write or Write then Read can be executed under the same BR/BG bus mastership cycle.

29C94

6.6. INTEL Mode

DMA Transmit

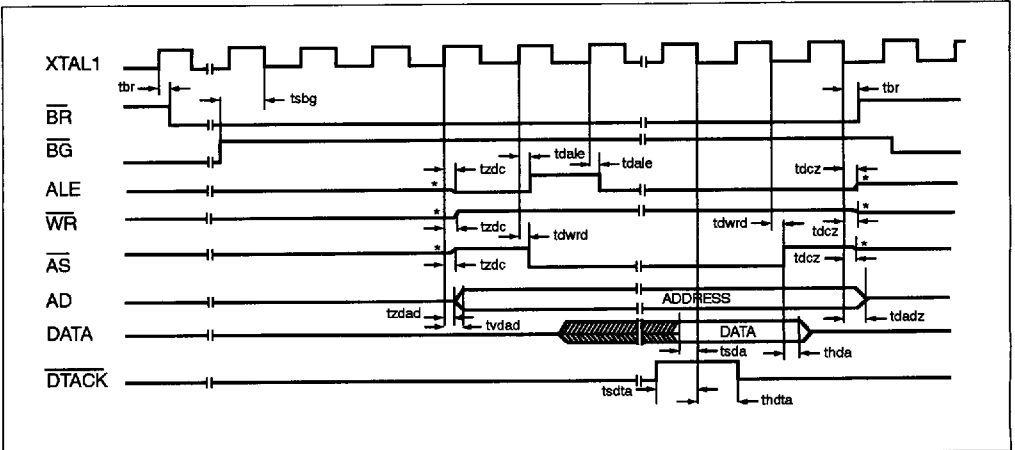

* WR, AS need external pull-up. ALE need external pull-down.

6.7. INTEL Mode

DMA Receive

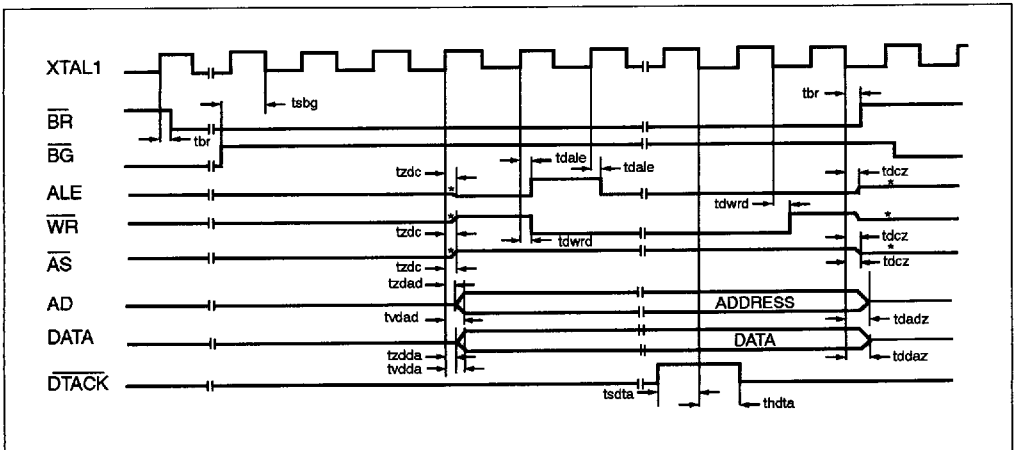

* WR, AS need external pull-up. ALE need external pull-down.

6.8. INTEL Mode DMA XMIT

Then DMA receive under the same Bus Request

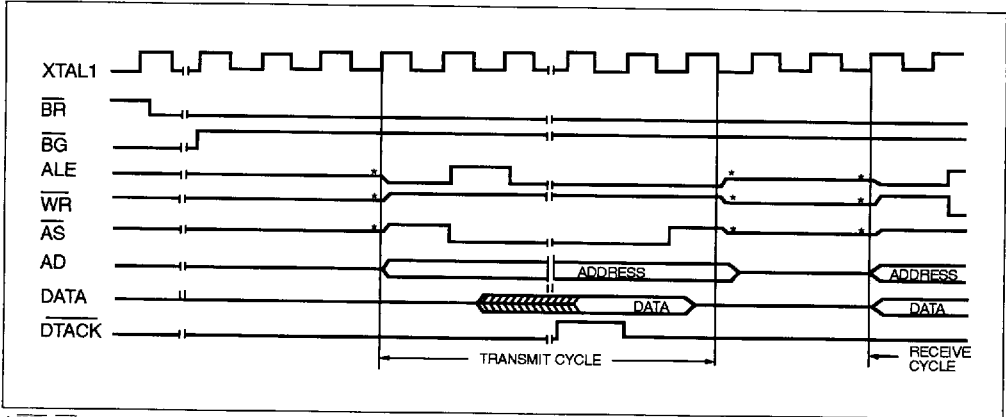

* WR, AS need external pull-up. ALE need external pull-down.

6.9. INTEL Mode DMA Receive

Then DMA XMIT under the same Bus Request

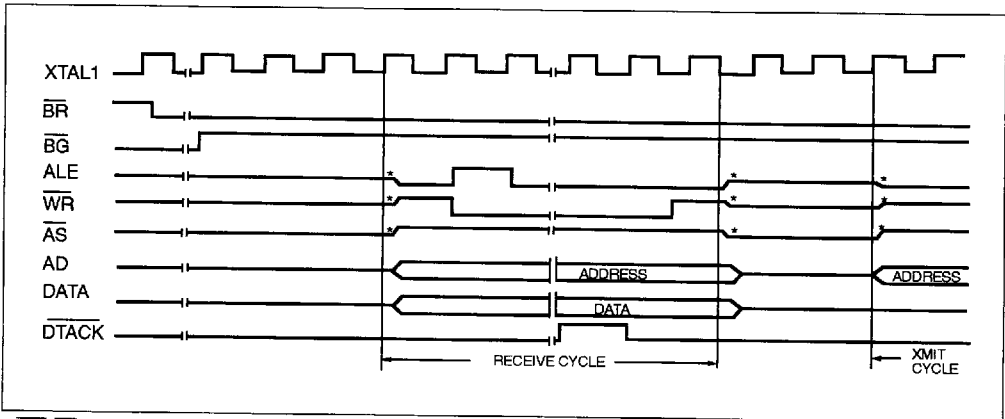

* WR, AS need external pull-up. ALE need external pull-down.

29C94

6.10. INTEL Mode

DAISY CHAIN

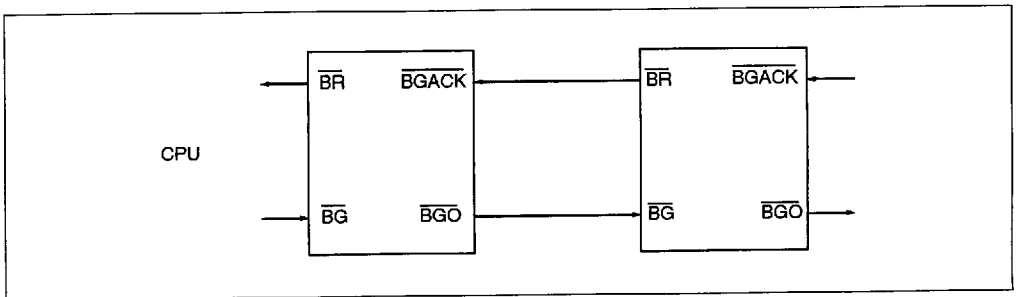
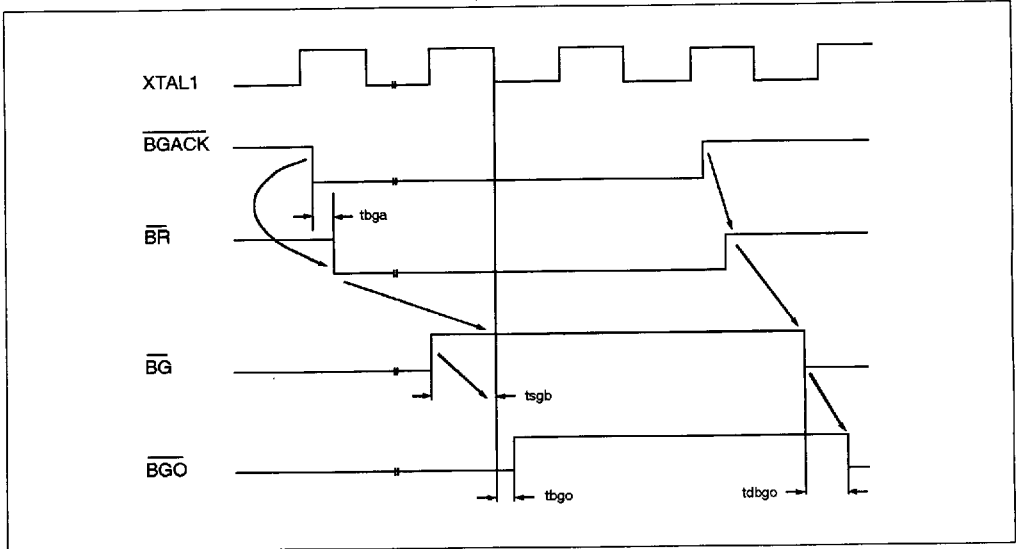

7.0 MOTOROLA CPU Driving System Bus

VCC = 5 V \pm 10 %, Temperature = 0 to 70°C,
150 pF Load on all Outputs except CLKOUT (50 pF)

Name	Description	Min ns	Typ ns	Max ns	Note
t _{clk}	XTAL clock period	30			
t _{wh}	XTAL high pulse width	12			
t _{wl}	XTAL low pulse width	12			
t _{sas}	setup address to AS	0			
t _{has}	hold address to AS	10			
t _{dwcs}	setup WR to AS/CS	5			
t _{dcd}	setup AS/CS to DS	0			
t _{sup}	setup DS to XTAL1	0			note 1
t _{zd}	delay CS to DTACK driving			12	
t _{dd}	delay DS to DTACK			10	
t _{ddt}	delay XTAL edge to DTACK			34	
t _{ddtr}	delay XTAL edge to DTACK			26	note 3
t _{dz}	delay CS to DTACK floating			24	
t _{sdata}	setup DATA to DTACK	45			note 2
t _{hdata}	hold DATA to DTACK	-15			
t _{sdatar}	setup DATA to DTACK	29			note 3
t _{hdatar}	hold DATA to DTACK	-8			note 3
t _{cyw}	internal write cycle time	2/3 t _{clk}	2/3 t _{clk}	2/3 t _{clk}	note 2
t _{cyr}	internal read cycle time	2/3 t _{clk}	2/3 t _{clk}	2/3 t _{clk}	note 2
t _{za}	delay AS to DATA driving			14	
t _{az}	delay AS to DATA floating			17	
t _{zd}	delay XTAL1 to data valid			70	
t _{sdt}	setup DATA to DTACK				t _{clk} + t _{ddt} - t _{xd}
t _{sdr}	setup DATA to DTACK	6			note 3
t _{hds}	hold DATA to DS	6			

- Notes :
- AS, WR, CS may be asynchronous with respect to XTAL1, however "t_{sup}" setup time to the following XTAL1 rising edge must be res to insure that this rising edge will trig the internal R/W cycle overwize, one additionnal t_{clk} will be added to thz R/W cycltime ti.
 - As the internal RAM uses 2 XTAL periods for internal R/W cycle, 2 or 3 XTAL periods are necessary from AS/WR resynchronized falling edge to internal cycle completion (DTACK rising).
 - Register access only.

2

29C94

7.1. MOTOROLA Mode

Memory Read

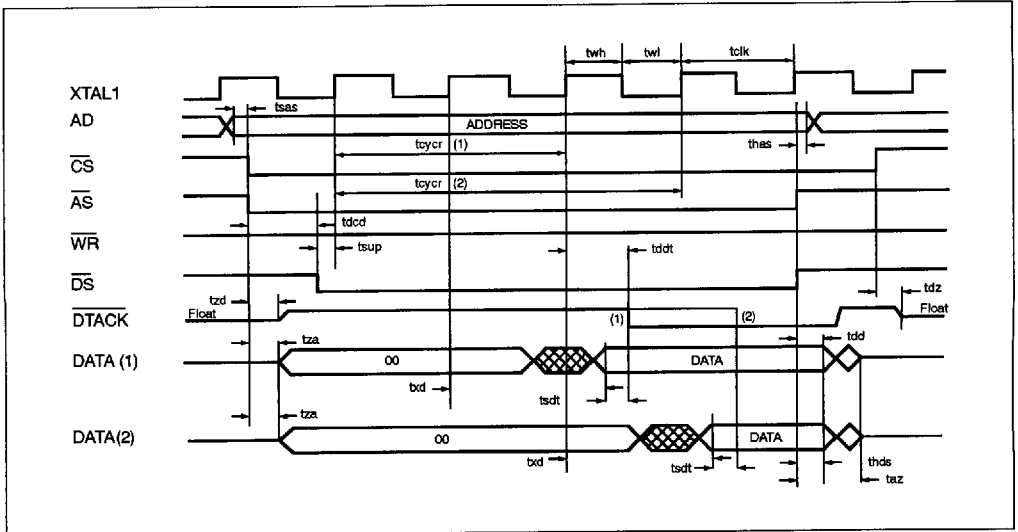

- 1) Shortest cycle
- 2) Longest cycle

7.2. MOTOROLA Mode

Memory Write

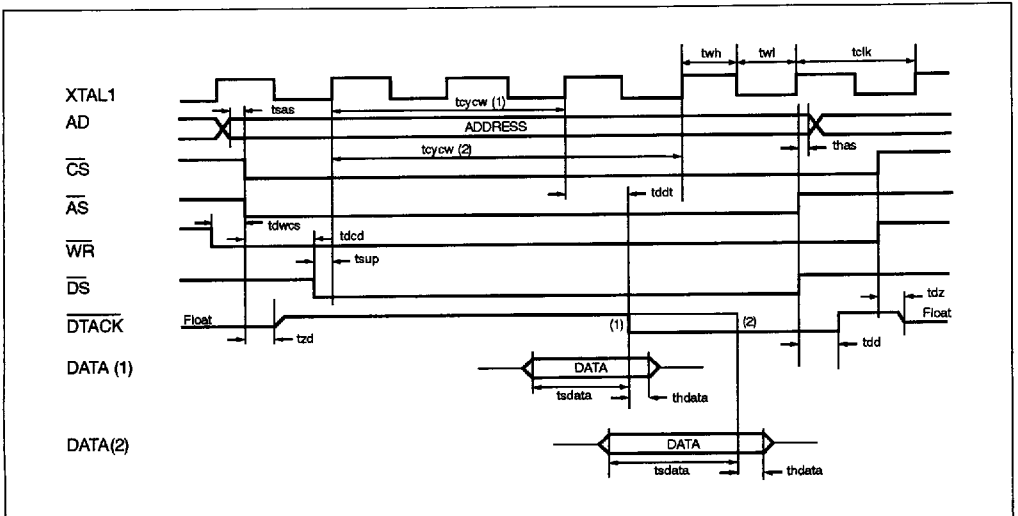

- 1) Shortest cycle
- 2) Longest cycle

7.5. MOTOROLA CPU – DMA Cycle.

VCC = 5 V ± 10 %, Temperature = 0 to 70 °C,
150 pF Load on all Outputs except CLKOUT (50 pF)

Name	Description	Min ns	Typ ns	Max ns	Note
t _{br}	Delay XTAL1 to BR			30	
t _{sbg}	Set-up BG to XTAL1	0			
t _{sasb}	Set-up AS to XTAL1	9			
t _{dbrb}	Delay BG to BR			27	
t _{dbga}	Delay XTAL1 to BGACK			30	
t _{zdc}	Delay XTAL1 to Bus control driving (AS, WR, ALE)			27	
t _{zgbg}	Delay XTAL1 to BGACK driving			28	
t _{zdad}	Delay XTAL1 to Add bus driving			38	
t _{vdad}	Delay XTAL1 to Add bus valid			39	
t _{zdada}	Delay XTAL1 to Data bus driv.			47	
t _{vdda}	Delay XTAL1 to Data bus valid			48	
t _{dwr}	Delay XTAL1 to AS/WR			26	
t _{dcz}	Delay XTAL1 to bus control float (AS, WR)			45	
t _{dadz}	Delay XTAL1 to Add. bus float			52	
t _{ddaz}	Delay XTAL1 to Data bus float			45	
t _{sdt}	Set-up DTACK to XTAL1	0			
t _{hdt}	Hold DTACK to XTAL1	17			
t _{sda}	Set-up Data bus to XTAL1	2			
t _{hda}	Hold Data bus to AS	- 20			note 1
t _{bgo}	Delay XTAL1 to BGO			34	

Notes : 1. t_{hda} shall be referenced to the XTAL1 falling edge that sample DT with the same figure.
Remarks : 2 DMA cycle Read then Write then Read can be executed under the same BR/BG bus mastership cycle.

MOTOROLA Mode

7.6. DMA Transmit

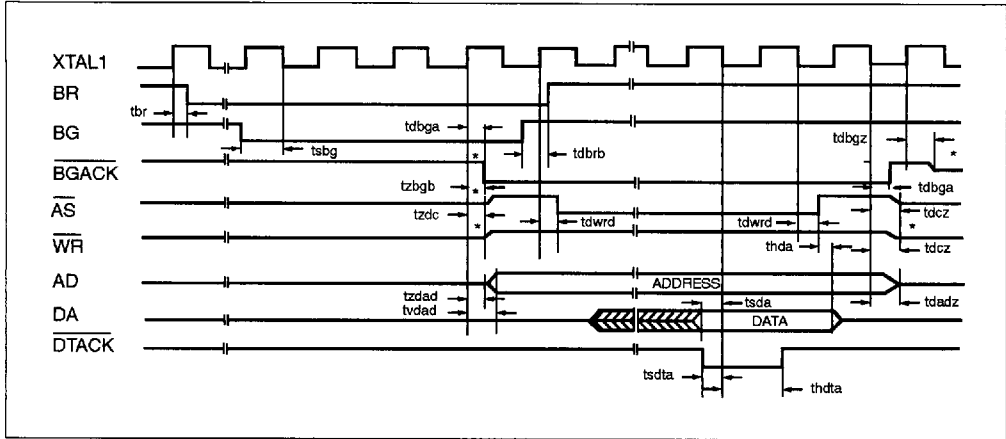

* BGACK, AS, WR need external pull-up.

2

MOTOROLA Mode

7.7. DMA Receiver

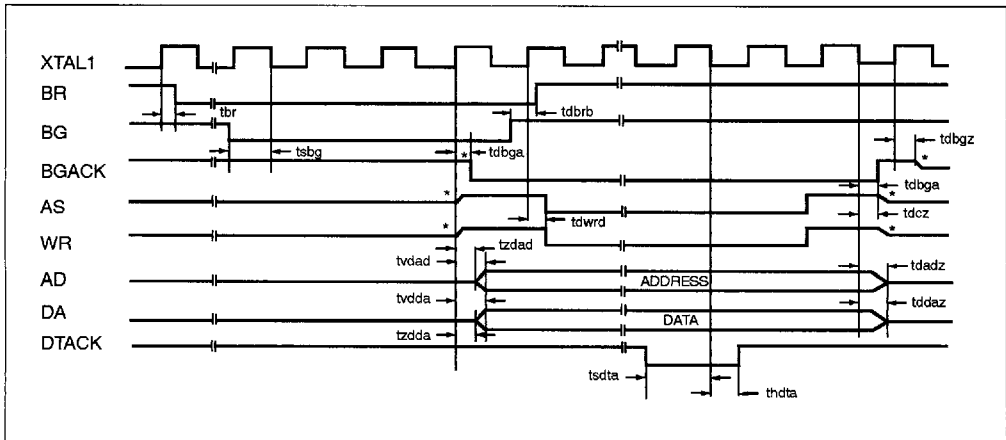

* BGACK, AS, WR need external pull-up.

29C94

MOTOROLA Mode DMA XMIT

7.8. Then DMA Receive under the same Bus Request

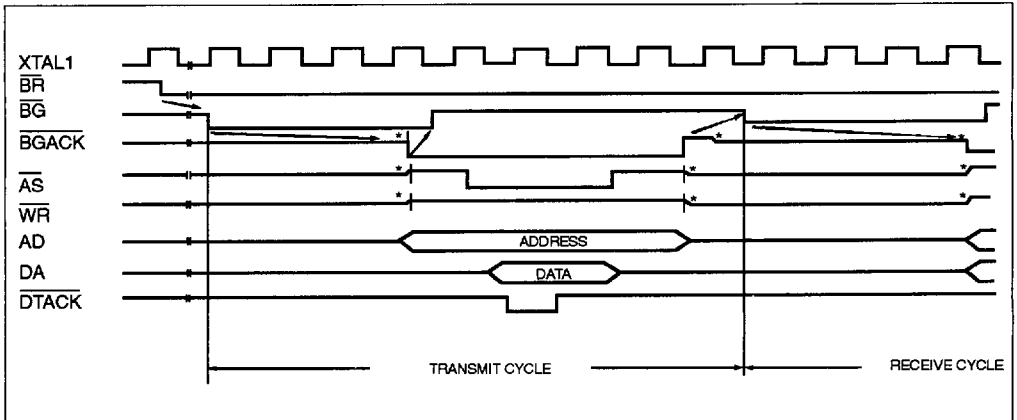

* BGACK, AS, WR need external pull-up.

MOTOROLA Mode DMA Receive

7.9. Then DMA Receive under the same Bus Request

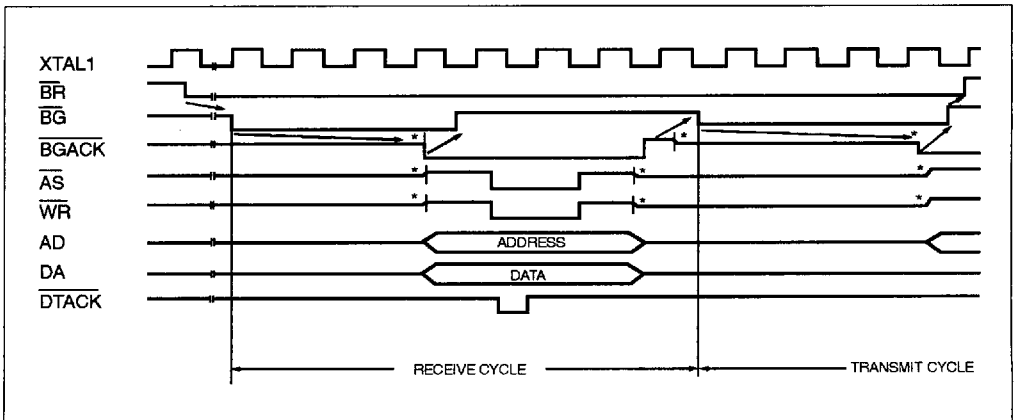

* BGACK, AS, WR need external pull-up.

MOTOROLA Mode DMA Cycle

7.10. Starting after CPU Cycle

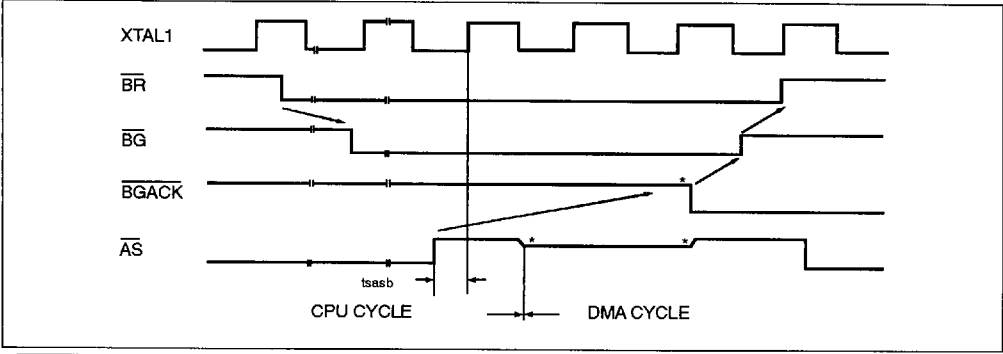

* BGACK, AS, WR need external pull-up.

7.11. DAISY CHAIN MOTOROLA

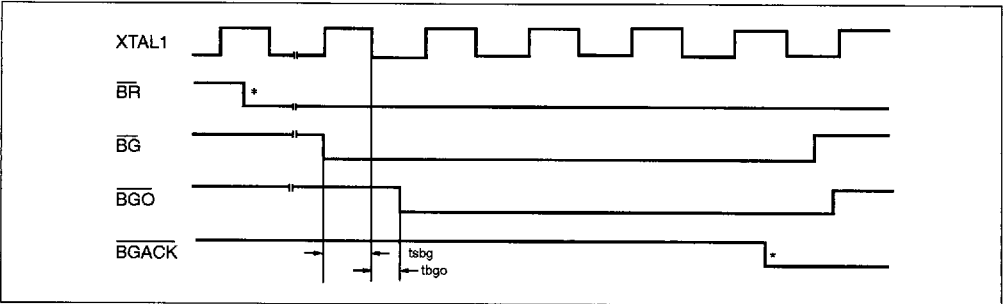

* BR and BG, are provided by a circuit in the daisy chain second position. The BGACK shown correspond to a 29C94 in the daisy chain second position with a common XTAL1 clock.

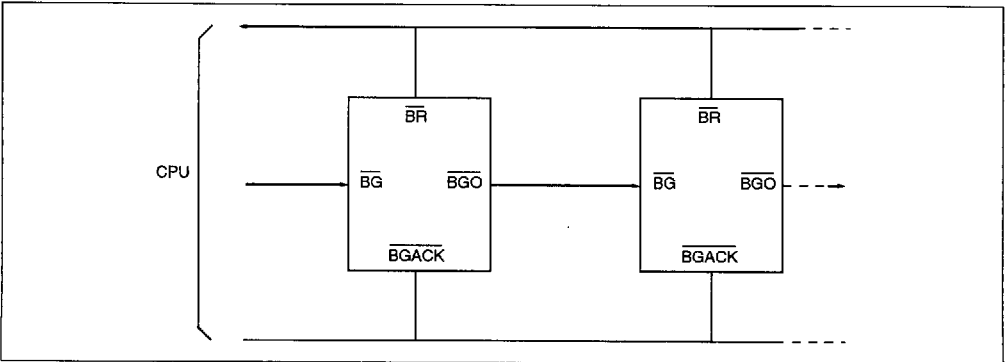

Ordering Information



TEMPERATURE RANGE
Ø COMMERCIAL 0 TO 70 °C
I INDUSTRIAL -40 TO 85 °C

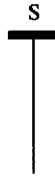

PACKAGE : S = PLCC

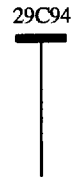

Part number
29C94

The information contained herein is subject to change without notice. No responsibility is assumed by MATRA MHS SA for using this publication and/or circuits described herein : nor for any possible infringements of patents or other rights of third parties which may result from its use.