

## 250 V/ $\mu$ s APC Amplifier with Integrated Photodiode and Gain Adjust Capability

### FEATURES

- Slew Rate of 250V/ $\mu$ s
- 7ns Settling Time to 1% for 1.5V Step
- 10 mV Output Offset Voltage
- 20 $\mu$ V/ $^{\circ}$ C Output Offset Drift
- Digital Gain Select
- +/- 6 dB External Gain Adjust

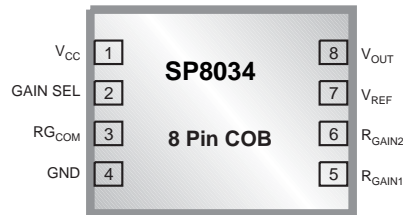

### DESCRIPTION

The SP8034 represents the next generation APC amplifier with integrated photodetector. This device monitors the light intensity of the laser diode in CD-R, CD-RW, DVD-R, DVD-RW and DVD-RAM assemblies by sensing the laser power with an integrated photodiode. The amplified signal from the APC contains the laser power information. This signal is subsequently fed back to the laser diode driver to control its power. The on-chip photodetector transforms incident light into a proportional current. This current is then converted to a voltage through a transimpedance amplifier. Adjustable gain is provided in the transimpedance amplifier by means of a gain control loop that is controlled by an external resistor. The external resistor is not part of the signal path, which greatly reduces the effects of all parasitic capacitances and inductances on the flex cable at these pins. The signal is buffered to provide reactive load drive capability.

The SP8034 achieves an unparalleled level of performance by combining excellent DC stability and low noise with outstanding AC performance. This level of performance is achieved using a proprietary fully complementary BiCMOS process with fully integrated, on-board photodetectors. The SP8034 is offered with a nominal gain of 2000V/W and is packaged in a 3.0mm x 3.5mm, 8 lead COB package.

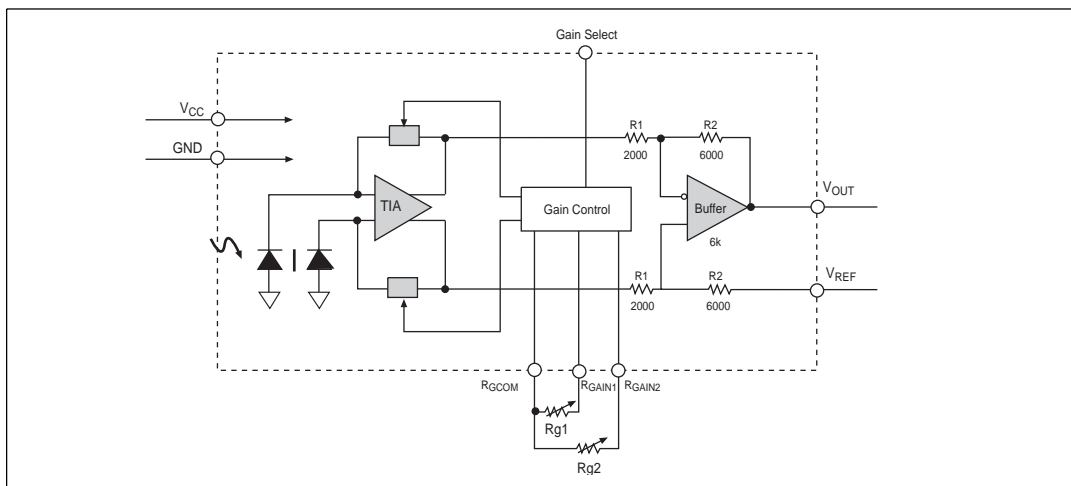

Figure 1. Functional Diagram

## ABSOLUTE MAXIMUM RATINGS

T <sub>J(MAX)</sub> .....	120°C
V <sub>S(MAX)</sub> .....	6V
V <sub>IN(MAX)</sub> .....	6V

These are stress ratings only and functional operation of the device at these ratings or any other above those indicated in the operation sections of the specifications below is not implied. Exposure to absolute maximum rating conditions for extended periods of time may affect reliability.

## ELECTRICAL SPECIFICATIONS

Unless otherwise noted: +4.5V ≤ V<sub>CC</sub> ≤ +5.5V, C<sub>LOAD</sub> = 50pF to GND, R<sub>GAIN</sub> = 400Ω and R<sub>LOAD</sub> = 1kΩ to V<sub>REF</sub>.  
0°C ≤ T<sub>A</sub> ≤ +70°C, V<sub>REF</sub> = 2.1V

PARAMETER	CONDITIONS	MIN	TYP	MAX	UNITS
Supply Voltage		4.5	5	5.5	V
Output Sensitivity SP8034	Any Select Mode. Laser Beam Diameter = 0.70mm, uniform density		2000		V/W
Output Sensitivity Change vs. V <sub>CC</sub>	R <sub>GAIN</sub> = 950Ω			5	%/V
Output Sensitivity Change vs. Temp	R <sub>GAIN</sub> = 950Ω			0.1	%/°C
Input Optical Power Required to Produce 1.5V Output Swing SP8034	Any Select Mode		0.75		mW
Full Scale Output Voltage Swing(Vp-p)	Relative to V <sub>REF</sub>	-1.5	-1.7		V
Voltage Reference Range	R <sub>GAIN</sub> = 400Ω	1.9	2.1	2.3	V
Output Offset Voltage		-10		10	mV
Output Offset Voltage Drift	R <sub>GAIN</sub> = 400Ω			25	μV/°C
	R <sub>GAIN</sub> = 950Ω			50	μV/°C
Output Noise	BW: 1kHz to 1MHz		1	2	mV
Output Noise	BW: 1kHz to 100MHz		3	5	mV
Output Slew Rate		200	250		V/μs
Output Settling Time to 1% of Final Value, 1.5V Step			7	15	ns
Output Overshoot, 1.5V Step				5	%
Bandwidth (-3db)	R <sub>GAIN</sub> = 400Ω	65	100		MHz
PSRR* Output Offset Voltage					
	R <sub>GAIN</sub> = 400Ω	55	73		dB
	R <sub>GAIN</sub> = 950Ω	50	75		dB
Power Supply Current	T <sub>A</sub> = 25°C Full Temp		20	25	mA
Gain Adjust Range V <sub>CC</sub> =+5.0V	150Ω < R <sub>GAIN</sub> < 950Ω	-6		+6	dB
Gain Adjust Range V <sub>CC</sub> =+4.5V	250Ω < R <sub>GAIN</sub> < 950Ω	-3		+6	dB
Input Voltage V <sub>low</sub> (TTL Level) V <sub>high</sub> (TTL Level)				0.8	V
		2.4			V
T <sub>JA</sub> , 3mm x 3.5mm Package			90		°C/W

$$* PSRR = 20 * \log ( \Delta V_{SUPPLY} / \Delta V_{OUT} )$$

PIN NUMBER	NAME	FUNCTION
1	V <sub>CC</sub>	Supply Voltage
2	GAIN	GAIN Select
3	R <sub>GCOM</sub>	Common connection point for R <sub>GAIN1</sub> and R <sub>GAIN2</sub>
4	GND	Power Ground
5	R <sub>GAIN1</sub>	Gain Adjust 1 (Gain Select = LOW)
6	R <sub>GAIN2</sub>	Gain Adjust 2 (Gain Select = HIGH)
7	V <sub>REF</sub>	Reference Voltage
8	V <sub>OUT</sub>	Output Voltage

THEORY OF OPERATION

The SP8034 is an Automatic Power Control (APC) circuit for pick-up head applications. The part consists of a photo-detector that converts the light (780nm or 650nm) into current, and active circuitry (transimpedance amplifier and buffer) to convert the current into voltage. The overall transfer characteristics are therefore represented by a Voltage per Watt curve.

There are three pins for gain adjust, using two separate external resistors for two separate gain modes. This allows different adjust for a DVD and a CD mode.

The two resistors are each tied from the corresponding RG pin (pin 5 or 6, depending on the mode) to the common gain pin (pin 3). The gain adjust is proportional to the external resistance and is done by means of an analog duplication circuit that translates the resistance value in an active feedback circuit at the transimpedance amplifier. The fact that the external resistor is not in the signal path ensures a better signal quality and immunity to the parasitic capacitance/inductance on the pins 3,5 and 6.

In dark condition, the output of the circuit will remain at the externally supplied V<sub>REF</sub> (1.9V ≥ 2.3V). When light (650nm or 780nm) is received on the photo-diode, the output (V<sub>OUT</sub>, pin 8) will swing negative with respect to V<sub>REF</sub>. The output swing is guaranteed to be at least 1.5V from V<sub>REF</sub>. For example, with V<sub>REF</sub> at 2V, the output can swing at least as low as 0.5V (absolute).

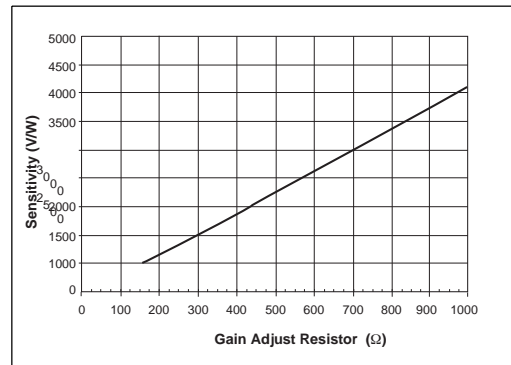

Figure 2. Sensitivity vs. Gain Resistor (Absolute)

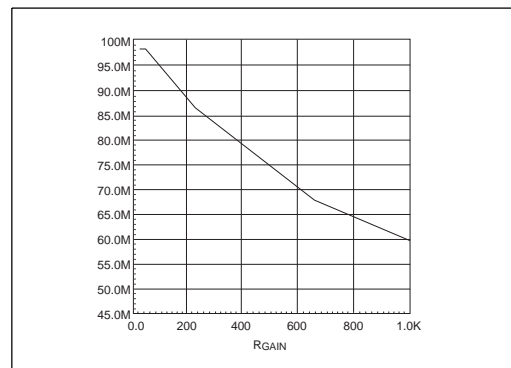

Figure 3. System Bandwidth versus Gain Resistor, V<sub>CC</sub> = 5V, T = 27C.

Gain (dB)	Sensitivity (mV/mW)	Regain (Ω)	Ts(nS) 1%	BW (MHz)	Pin(uW)
+6	4	950	13	61	380
0	2	400	12	79	750
-3	1.4	250	11	87	1070
-6 *	1	150	10	93	1500

\* V<sub>CC</sub> ≥ 5.0V

Table 1. Target Gain Set Points for the System.

A major consideration in developing the optical pick-up head system is the extremely small form factor, which is additionally aggravated by the physical locations required by the light path. Special care must be taken when designing the Flex or PCB for this part. The output peak current requirement is in the order of 12.5 mA when driving 50pF of capacitive load with a slew rate of 250V/μs. Therefore care must be taken to provide low inductance, low resistance paths for power and ground and output traces. Supply coupling is also very important. Good supply decoupling is important to ensure the high frequency performance of the system by eliminating supply lead inductance effects. The decoupling capacitor C1, as shown in Figure 5, should be as close to the part as possible.

This capacitor should be 0.1μF ceramic. C2 is optional to improve decoupling and is recommended to be 1 μF tantalum. The layout of the PCB is pictured here. Note the wide and short traces on the supply lines.

The traces for the gain resistors R<sub>GAIN1</sub> and R<sub>GAIN2</sub> are kept as short as possible to avoid excessive parasitics. Any parasitics on these nodes will limit the performance of the system. R<sub>GAIN1</sub> and R<sub>GAIN2</sub> are subminiature potentiometers in the application. This is a single layer board using FR4 material.

In order to minimize coupling capacitance into the gain setting resistor nodes, it is also critical that V<sub>OUT+</sub> and V<sub>OUT-</sub> are routed away from the traces associated with the gain-setting resistors.

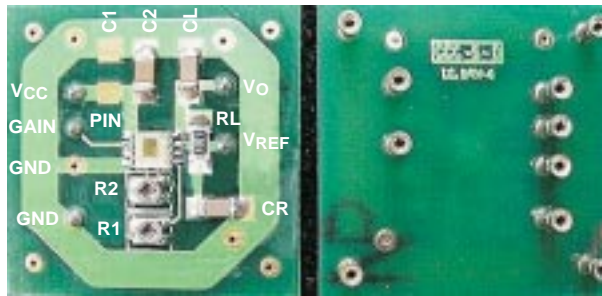

Figure 4. Evaluation Board.

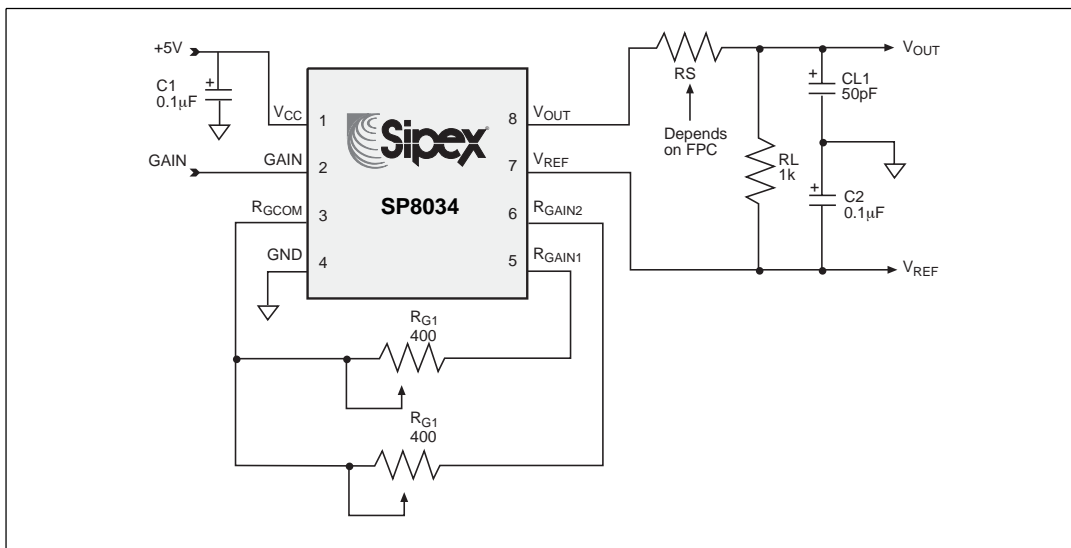
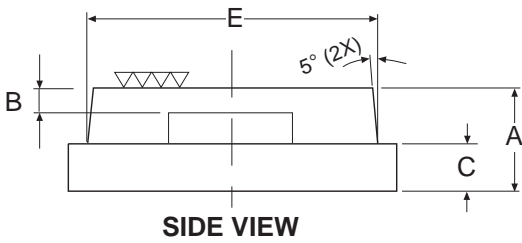
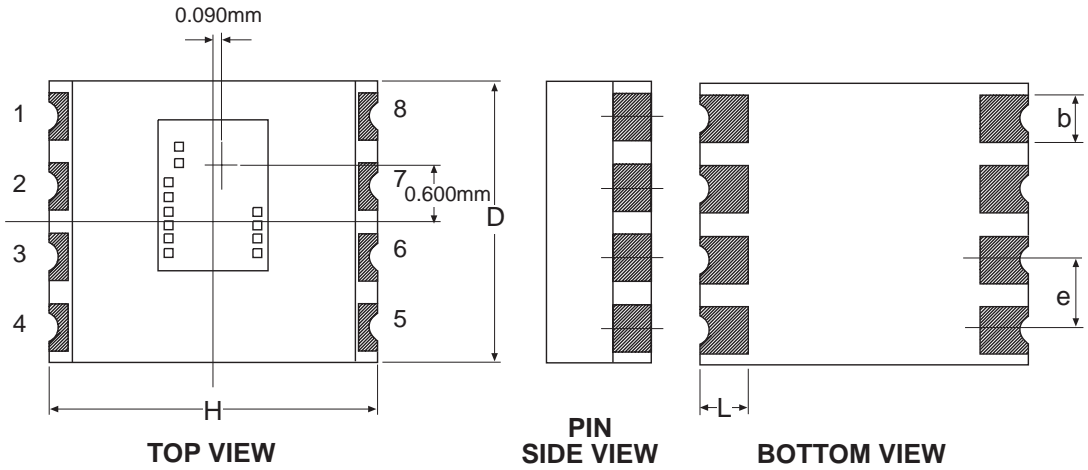
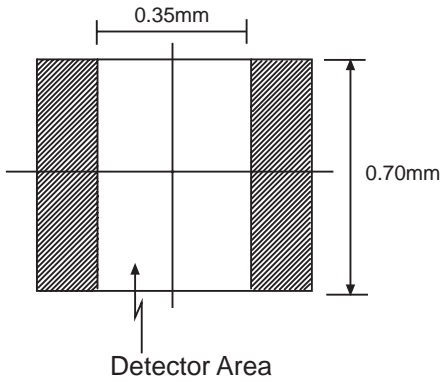

Figure 5. Test Circuit - Cload = 50p, V<sub>CC</sub> = 5V, Gain = 0V, Rgain = 400.



**DETECTOR SIZE**



DIMENSIONS in mm Minimum/Maximum	8-PIN COB
A	0.90/1.10
B	.127/.33
b	0.30/0.50
C	0.50 nom
D	2.90/3.10
E	3.00/3.20
e	0.75 nom
H	3.40/3.60
L	0.40/0.60

