

ASSP

1 CHANNEL 8-BIT VIDEO A/D CONVERTER

MB40578

■ DESCRIPTION

The Fujitsu MB40578 is a low power ultra-high speed video A/D converter fabricated with Fujitsu Advanced Bipolar Technology. The MB40578 also adopts the fully-parallel comparison technique (flash method) for high speed conversion and can convert wide band analog signal such as video signal to digital signal at a sampling rate of DC through 20 Mega-samples/sec. Because of such high-speed operation, the MB40578 is suitable for digital video applications such as the digital TV, video processing with computer, or radar signal processing.

■ FEATURES

- Resolution: 8 bits
- Linearity error: $\pm 0.2\%$ max. (MB40578)
- Maximum conversion rate: 20 MSPS min.
- Analog input voltage: 3.0V to 5.0V
- Digital I/O level: TTL compatible
- Single power supply: +5V
- Power Dissipation: 480mW typ.
- Package: Standard 22-pin DIP Package: Suffix: -P

■ PACKAGE

Plastic DIP, 22 pin

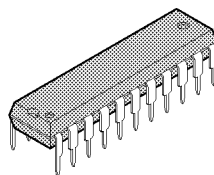

(DIP-22P-M04)

MB40578

■ PIN ASSIGNMENT

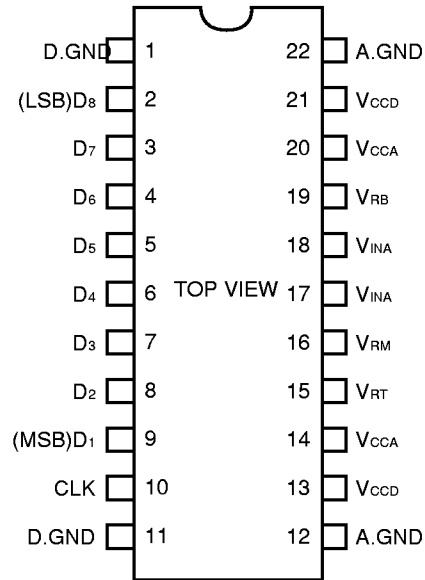

■ BLOCK DIAGRAM

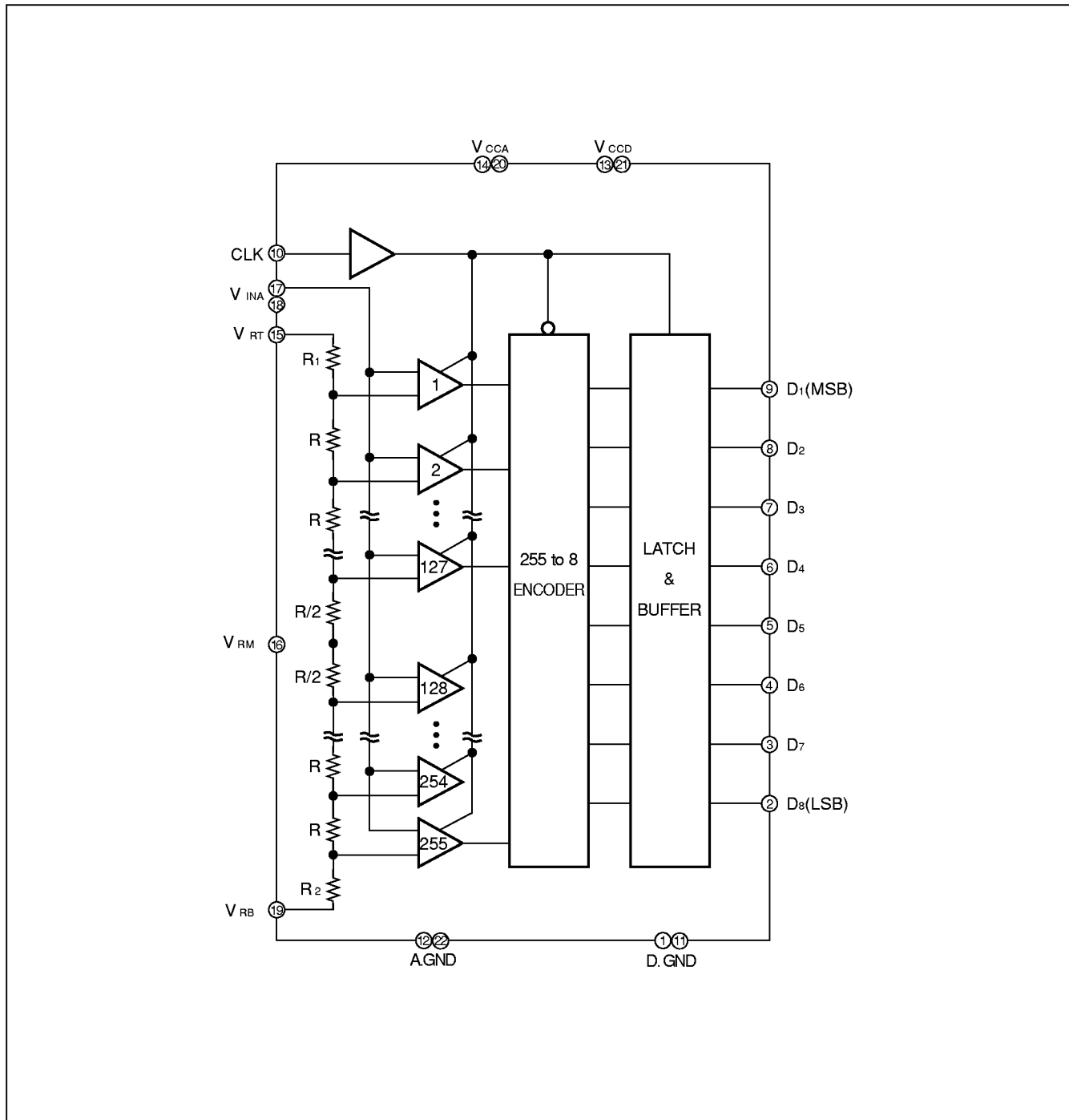

MB40578

■ ABSOLUTE MAXIMUM RATINGS

Parameter	Symbol	Rating	Unit
Power supply voltage	V _{CCA} V _{CCD}	-0.5 to +7.0	V
Digital input voltage	V _{IND}	-0.5 to +7.0	V
Analog input voltage	V _{INA}	-0.5 to V _{CC} +0.5	V
Analog reference voltage	V _{RT} , V _{RB}	-0.5 to V _{CC} +0.5	V
Storage temperature	V _{STG}	-55 to +125	°C

Note: Permanent device damage may occur if the above Absolute Maximum Ratings are exceeded. Functional operation should be restricted to the conditions as detailed in the operational sections of this data sheet. Exposure to absolute maximum rating conditions for extended periods may affect device reliability.

■ RECOMMENDED OPERATING CONDITIONS

Parameter	Symbol	Value			Unit
		Min	Typ	Max	
Power supply voltage*1	V _{CCA} V _{CCD}	4.75	5.00	5.25	V
Analog input voltage*2	V _{INA}	3	—	5	V
Analog reference voltage (Top side)*2	V _{RT}	—	5	5.1	V
Analog reference voltage (Bottom side)*2	V _{RB}	2.9	3	—	V
Digital high-level output current	I _{OHD}	-400	—	—	μA
Digital low-level output current	I _{OLD}	—	—	4	mA
Clock pulse width at high level	t _{w+}	25	—	—	ns
Clock pulse width at low level	t _{w-}	25	—	—	ns
Operating temperature	T _a	0	—	70	°C

Notes: *1: Please keep V_{CCA} and V_{CCD} at the same potential.

*2: V_{RB} < V_{INA} < V_{RT}, V_{RT} - V_{RB} = 2V + 0.1V.

■ ELECTRICAL CHARACTERISTICS

1. Analog DC Characteristics

($V_{CCA} = V_{CCD} = 5V \pm 5\%$, $T_a = 0$ to 70°C)

Parameter	Symbol	Condition	Value			Unit
			Min	Typ	Max	
Resolution			—	—	8	bits
Linearity error	LE	DC	—	—	± 0.2	%
Equivalent resistance for analog input	R_{INA}		50	—	—	$k\Omega$
Analog input capacitance	C_{INA}		—	120	230	pF
Analog high-level input current	I_{IHA}		—	—	150	μA
Analog low-level input current	I_{ILA}		—	—	145	μA
Reference current	I_{RB}	$V_{RT} = 5V$ $V_{RB} = 3V$	-15	-9	—	mA

2. Digital DC Characteristics

($V_{CCA} = V_{CCD} = 5V \pm 5\%$, $T_a = 0$ to 70°C)

Parameter	Symbol	Condition	Value			Unit
			Min	Typ	Max	
High-level output voltage	V_{OH}	$I_{OH} = -400 \mu\text{A}$	2.7	—	—	V
Low-level output voltage	V_{OL}	$I_{OL} = 1.6 \text{ mA}$	—	—	0.4	V
High-level input voltage	V_{IHD}		2	—	—	V
Low-level input voltage	V_{ILD}		—	—	0.8	V
Maximum input current	I_{ID}	$V_{ID} = 7V$	—	—	100	μA
High-level input current	I_{IHD}	$V_{IHD} = 2.7V$	—	0	20	μA
Low level input current	I_{ILD}	$V_{ILD} = 0.4V$	-400	-40	—	μA
Power supply current	I_{CC}		—	92	160	mA

MB40578

3. Switching Characteristics

($V_{CCA} = V_{CCD} = 5V \pm 5\%$, $T_a = 0$ to 70°C)

Parameter	Symbol	Condition	Value			Unit
			Min	Typ	Max	
Maximum conversion rate	FS		20	30	—	MSPS
Digital output delay time	tpd		5	15	40	ns

Figure 1 Timing Diagram

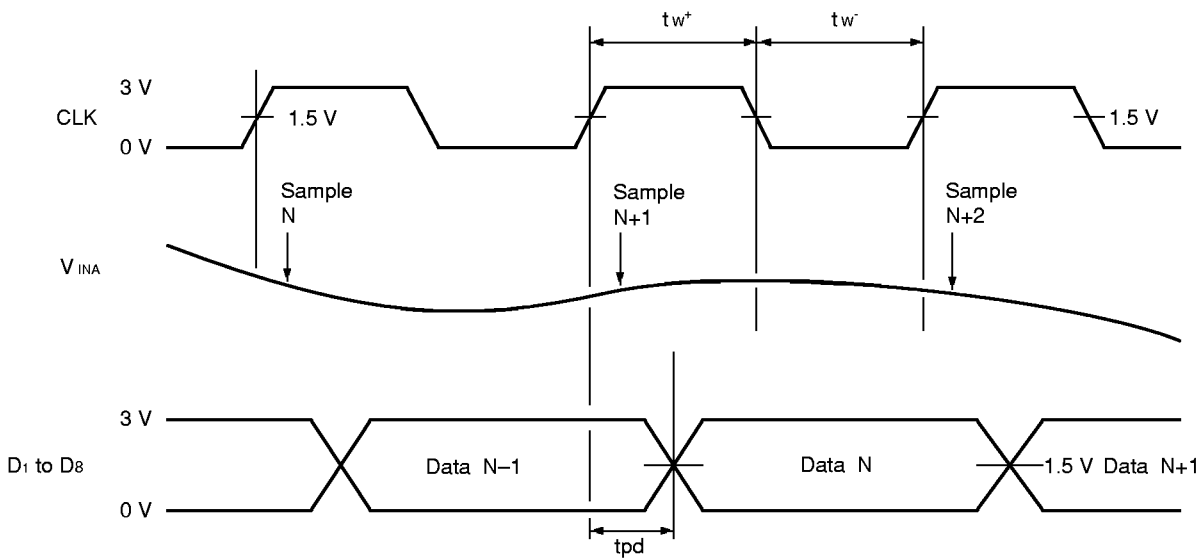
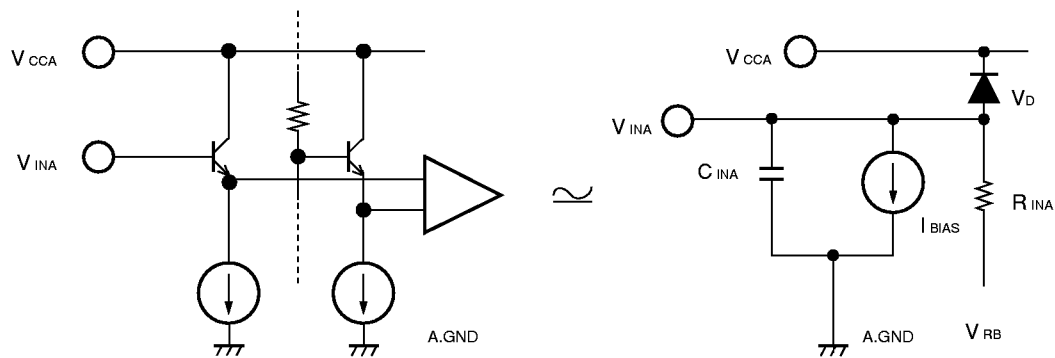

Figure 2 Analog Input Equivalent Circuit



X255 Circuits

C_{INA} : Non-linear Emitter-follower Junction Capacitance

R_{INA} : Linear Resistance Model for Input Current Transition by Comparator Switching:
Infinite value for $V_{IN} < V_{RB}$ or when CLK = High

V_{RB} : Voltage at V_{RB} terminal

I_{BIAS} : Constant Input Bias Current

V_D : The base-collector junction diode of emitter-follower transistor.

Figure 3 Digital Input Equivalent

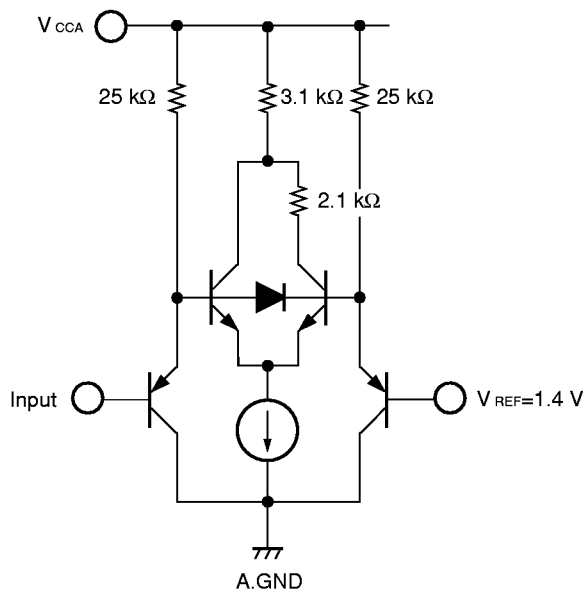
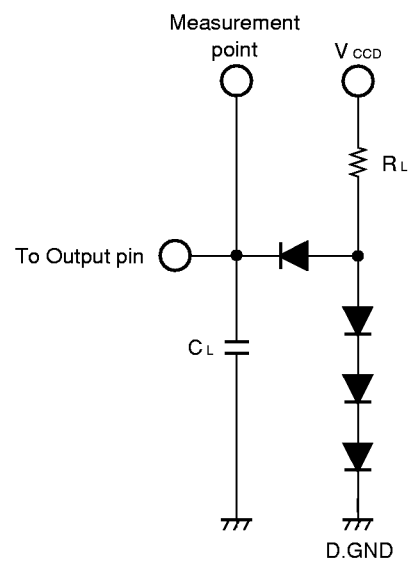

Figure 4 Load Circuit for Output Buffer



Note $R_L = 2 \text{ k}\Omega$

$C_L = 15 \text{ pF}$ including scope and jig capacitance

Diodes: IN3064 or equivalent

Figure 5 Output Code

($V_{CC}=5.0\text{ V}$, $V_{RT}=5.0\text{ V}$, $V_{RB}=3.0\text{ V}$)

Step	Analog Input Voltage	OUTPUT VOLTAGE(V)
0	2.960 V	00000000
1	2.968 V	00000001
⋮	⋮	⋮
127	3.976 V	01111111
128	3.984 V	10000000
129	3.992 V	10000001
⋮	⋮	⋮
245	4.992 V	11111110
255	5.000 V	11111111

Note : Adjust $V_{ZT}=2.964\text{ V}$ and $V_{FT}=4.996\text{ V}$ with V_{RT} and V_{RB} . The Analog Input Voltage are the center values of each step.

Figure 6 Ideal Conversion Characteristics

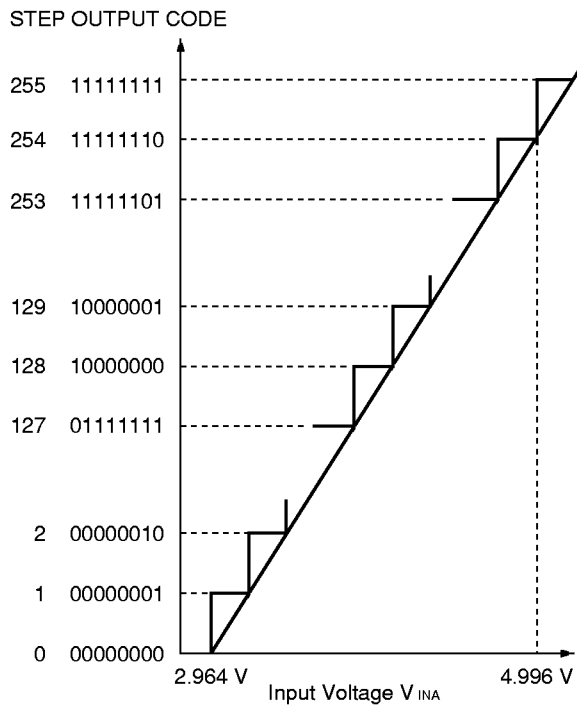
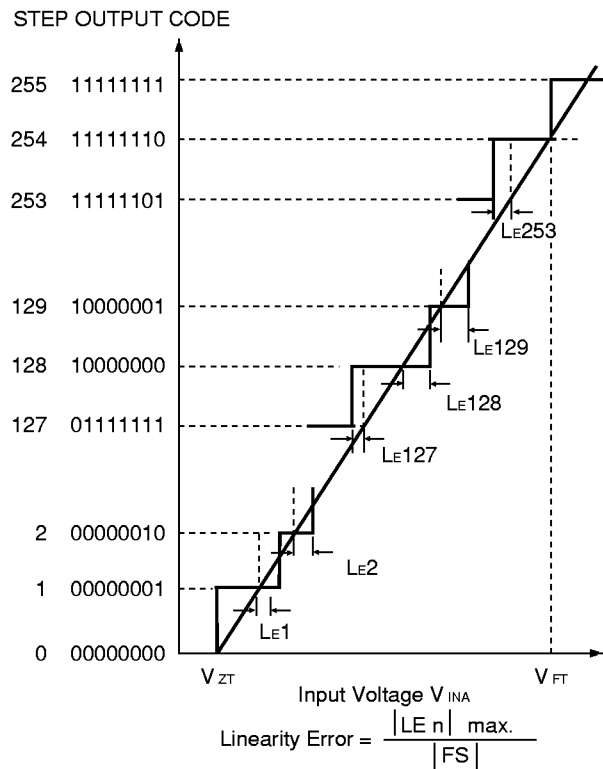
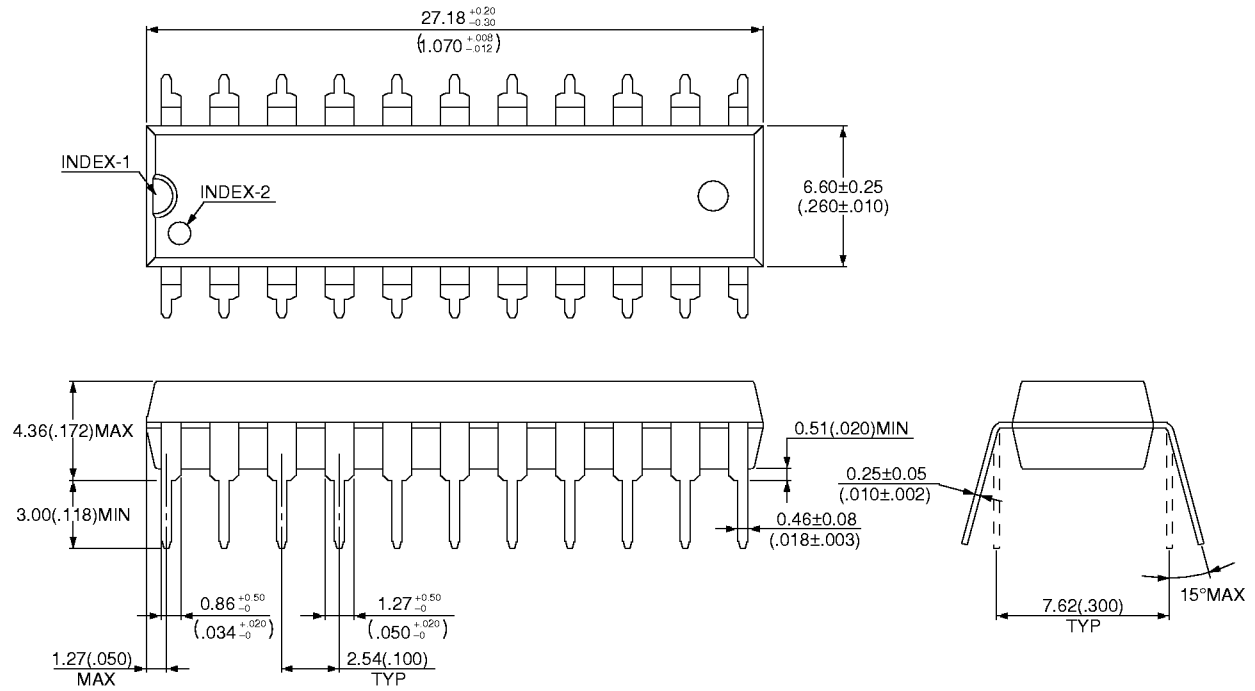

Figure 7 Actual Conversion Characteristics



■ PACKAGE DIMENSION

Plastic DIP, 22 pin
(DIP-22P-M04)



© 1994 FUJITSU LIMITED D22008S-4C-3

Dimensions in mm (inch)

FUJITSU LIMITED

For further information please contact:

Japan

FUJITSU LIMITED
Corporate Global Business Support Division
Electronic Devices
KAWASAKI PLANT, 4-1-1, Kamikodanaka
Nakahara-ku, Kawasaki-shi
Kanagawa 211-88, Japan
Tel: (044) 754-3763
Fax: (044) 754-3329

North and South America

FUJITSU MICROELECTRONICS, INC.
Semiconductor Division
3545 North First Street
San Jose, CA 95134-1804, U.S.A.
Tel: (408) 922-9000
Fax: (408) 432-9044/9045

Europe

FUJITSU MIKROELEKTRONIK GmbH
Am Siebenstein 6-10
63303 Dreieich-Buchsschlag
Germany
Tel: (06103) 690-0
Fax: (06103) 690-122

Asia Pacific

FUJITSU MICROELECTRONICS ASIA PTE. LIMITED
#05-08, 151 Lorong Chuan
New Tech Park
Singapore 556741
Tel: (65) 281-0770
Fax: (65) 281-0220

All Rights Reserved.

The contents of this document are subject to change without notice. Customers are advised to consult with FUJITSU sales representatives before ordering.

The information and circuit diagrams in this document presented as examples of semiconductor device applications, and are not intended to be incorporated in devices for actual use. Also, FUJITSU is unable to assume responsibility for infringement of any patent rights or other rights of third parties arising from the use of this information or circuit diagrams.

FUJITSU semiconductor devices are intended for use in standard applications (computers, office automation and other office equipment, industrial, communications, and measurement equipment, personal or household devices, etc.).

CAUTION:

Customers considering the use of our products in special applications where failure or abnormal operation may directly affect human lives or cause physical injury or property damage, or where extremely high levels of reliability are demanded (such as aerospace systems, atomic energy controls, sea floor repeaters, vehicle operating controls, medical devices for life support, etc.) are requested to consult with FUJITSU sales representatives before such use. The company will not be responsible for damages arising from such use without prior approval.

Any semiconductor devices have inherently a certain rate of failure. You must protect against injury, damage or loss from such failures by incorporating safety design measures into your facility and equipment such as redundancy, fire protection, and prevention of over-current levels and other abnormal operating conditions.

If any products described in this document represent goods or technologies subject to certain restrictions on export under the Foreign Exchange and Foreign Trade Control Law of Japan, the prior authorization by Japanese government should be required for export of those products from Japan.