

# DATA SHEET

**PCD4440T**

Analog voice  
scrambler/descrambler

Product specification  
Supersedes data of October 1992  
File under Integrated Circuits, IC03

1996 Dec 20

**Analog voice scrambler/descrambler****PCD4440T****CONTENTS**

1	FEATURES
2	APPLICATIONS
3	GENERAL DESCRIPTION
6	PINNING INFORMATION
6.1	Pinning
6.2	Pin description
7.1	Scrambling
7.2	Power supply ( $V_{DD}$ , $V_{SS}$ )
7.3	Oscillator (OSCI)
7.4	Splitting frequency and mode selection
7.5	Serial clock input (SCL), Serial data input (SDA)
7.6	Address input (A0)
7.7	I <sup>2</sup> C-bus data configuration
7.8	Signal input (IN), Signal output (OUT)
8	I <sup>2</sup> C BUS INTERFACE
8.1	Bit transfer
8.2	Start and stop conditions
8.3	System configuration
8.4	Acknowledge
8.5	Timing specifications
9	APPLICATIONS
10	HANDLING
11	LIMITING VALUES
12	CHARACTERISTICS
14.1	Introduction
14.2	Reflow soldering
14.3	Wave soldering
14.4	Repairing soldered joints
15	DEFINITIONS+
16	LIFE SUPPORT APPLICATIONS
17	PURCHASE OF PHILIPS I <sup>2</sup> C COMPONENTS

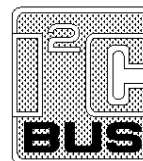

# Analog voice scrambler/descrambler

PCD4440T

## 1 FEATURES

- Scrambler or descrambler function
- Scrambling in frequency domain
- Selectable split frequency (up to 10 selections per second)
- Telephony-band filtering included
- No increase in bandwidth
- No external components required
- Small signal delay
- Insensitive to distortion and group delay of transmission channel
- Control via serial I<sup>2</sup>C-bus
- Low transfer loss of speech
- Mute option
- Transparent mode
- High signal input impedance
- Low signal output impedance
- Low power consumption.

## 2 APPLICATIONS

- Cordless telephones
- Security telephones
- Portable phones
- Private Mobile Radio (PMR).

## 3 GENERAL DESCRIPTION

The PCD4440T is a silicon gate CMOS integrated circuit intended to be used in cordless telephony, radio, and line telecommunications products utilizing a microcontroller for the control functions. The purpose of the device is to prevent unauthorized 'listening-in' on conversations. A major application is protection of the vulnerable radio link between a CT0 type cordless handset and its base unit. Analog scrambling/descrambling is based on the split frequency method realized in a sophisticated switched-capacitor technology. The PCD4440T is compatible with most microcontrollers and communicates via a two line bidirectional I<sup>2</sup>C-bus.

## 4 ORDERING INFORMATION

TYPE NUMBER	PACKAGE		
	NAME	DESCRIPTION	VERSION
PCD4440T	SO8	plastic small outline package; 8 leads; body width 7.5 mm	SOT176-1

# Analog voice scrambler/descrambler

# PCD4440T

## 5 BLOCK DIAGRAM

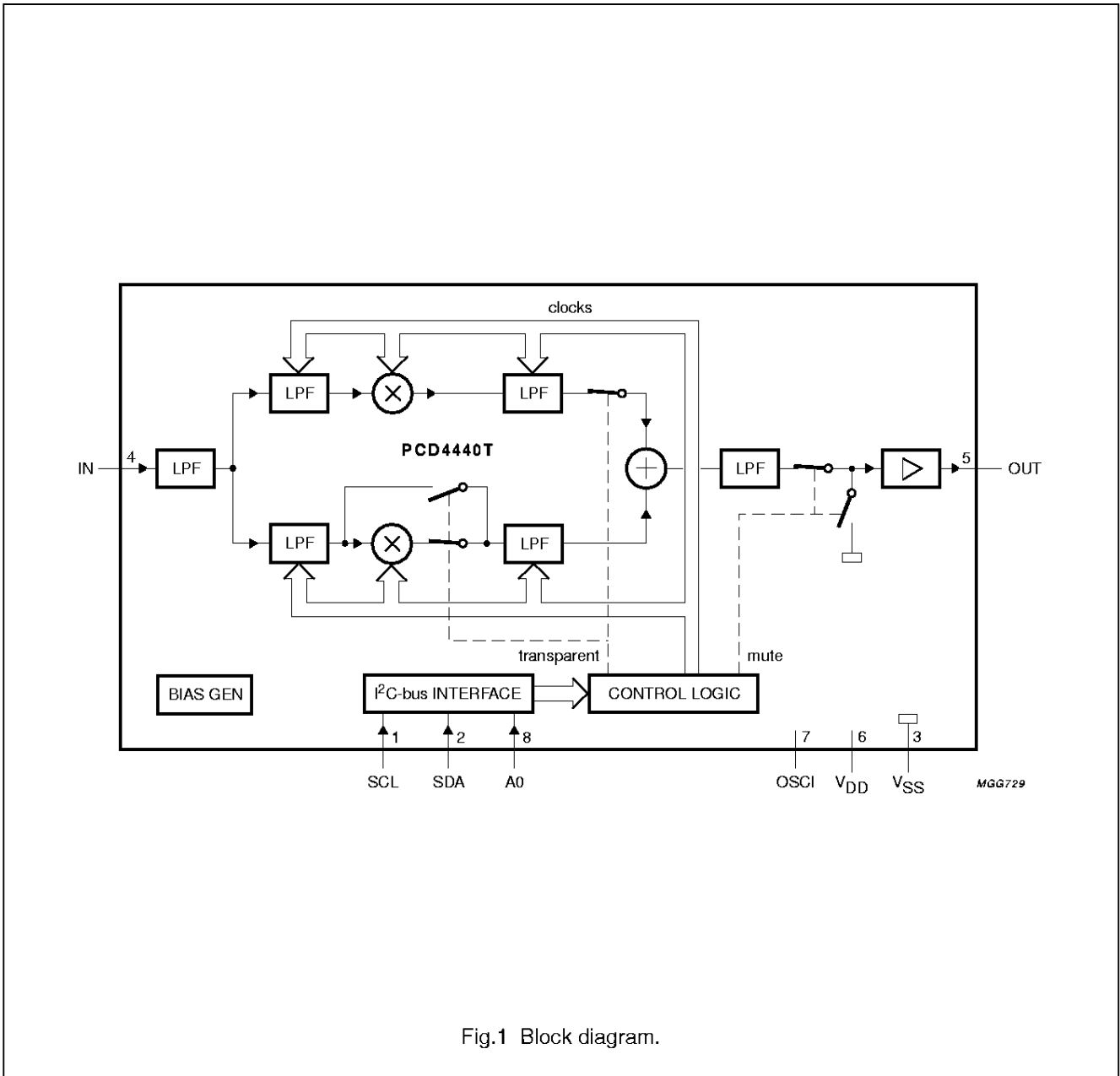

Fig.1 Block diagram.

# Analog voice scrambler/descrambler

# PCD4440T

## 6 PINNING INFORMATION

### 6.1 Pinning

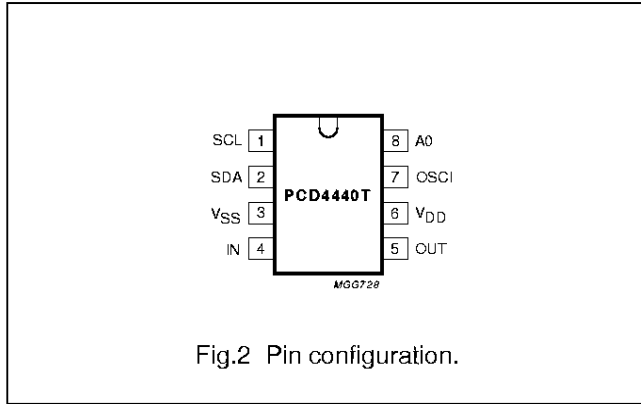

### 6.2 Pin description

SYMBOL	PIN	TYPE	DESCRIPTION
SCL	1	I	serial clock line (I <sup>2</sup> C-bus)
SDA	2	I	serial data line (I <sup>2</sup> C-bus)
V <sub>SS</sub>	3	P	negative Supply
IN	4	I	signal input
OUT	5	O	signal output
V <sub>DD</sub>	6	P	positive supply
OSCI	7	I	oscillator input
A0	8	I	slave address input (I <sup>2</sup> C-bus)

## 7 FUNCTIONAL DESCRIPTION

To provide privacy for the end user of a cordless telephone set, the radio-link audio signal must be scrambled. In the microphone of the handset and the incoming telephone line audio path of the base unit a scrambler circuit has to be implemented. Consequently the audio signal to the telephone line and to the earpiece must be descrambled. Both functions can be fulfilled by the PCD4440T by simply inserting it in the audio path.

### 7.1 Scrambling

The PCD4440T accomplishes this task by first filtering the incoming signal, limiting the bandwidth to 3500 Hz. Then the signal is split into a high ( $> f_s$ ) and a low ( $< f_s$ ) frequency band. Both frequency bands are inverted and added again to provide a single output signal. Values for 9 split frequencies  $f_s$  can be controlled by a scramble code table in the microcontroller. Control of these split frequencies is accomplished via the serial two-wire I<sup>2</sup>C-bus. In addition to the split frequencies ( $f_s$ ), a transparent mode and mute instruction can be selected (see Table 1).

Figure 3 shows the signal path for both bands. The lower band path (on the left side of the diagram) operates on frequencies  $f \leq f_s$  (Split Frequency), the upper band path (on the right side) on frequencies  $f \geq f_s$ .

The input signal contains frequencies from  $f_1$  up to  $f_2$ . In scrambling mode, the output signal is band limited from  $f_l$  (300 Hz) to  $f_h$  (3500 Hz). In the left path, the input signal is first limited to  $f_s$ . The following modulator inverts the lower band.  $f_l$  is folded up to  $f_s$ ,  $f_s$  down to  $f_l$ . In general, an input frequency  $f_{in}$  is folded to  $f_{out} = f_s + f_1 - f_{in}$ . Finally the folded signal is band limited to  $f_s$  again.

In the right path, the input signal is first limited to  $f_h$ . The following modulator inverts the upper band.  $f_s$  is folded up to  $f_h$ ,  $f_h$  down to  $f_s$ . In general, an input frequency  $f_{in}$  is folded to  $f_{out} = f_s + f_h - f_{in}$ . Finally, the folded signal is band limited to  $f_h$  again. In the last step, the bands are added and buffered.

Because of the symmetry of the scrambling process, descrambling is achieved by passing the signal through another PCD4440T.

In the transparent mode, the input signal is band limited to 3500 Hz. Frequencies from 0 to 300 Hz are not filtered out.

Analog voice scrambler/descrambler

PCD4440T

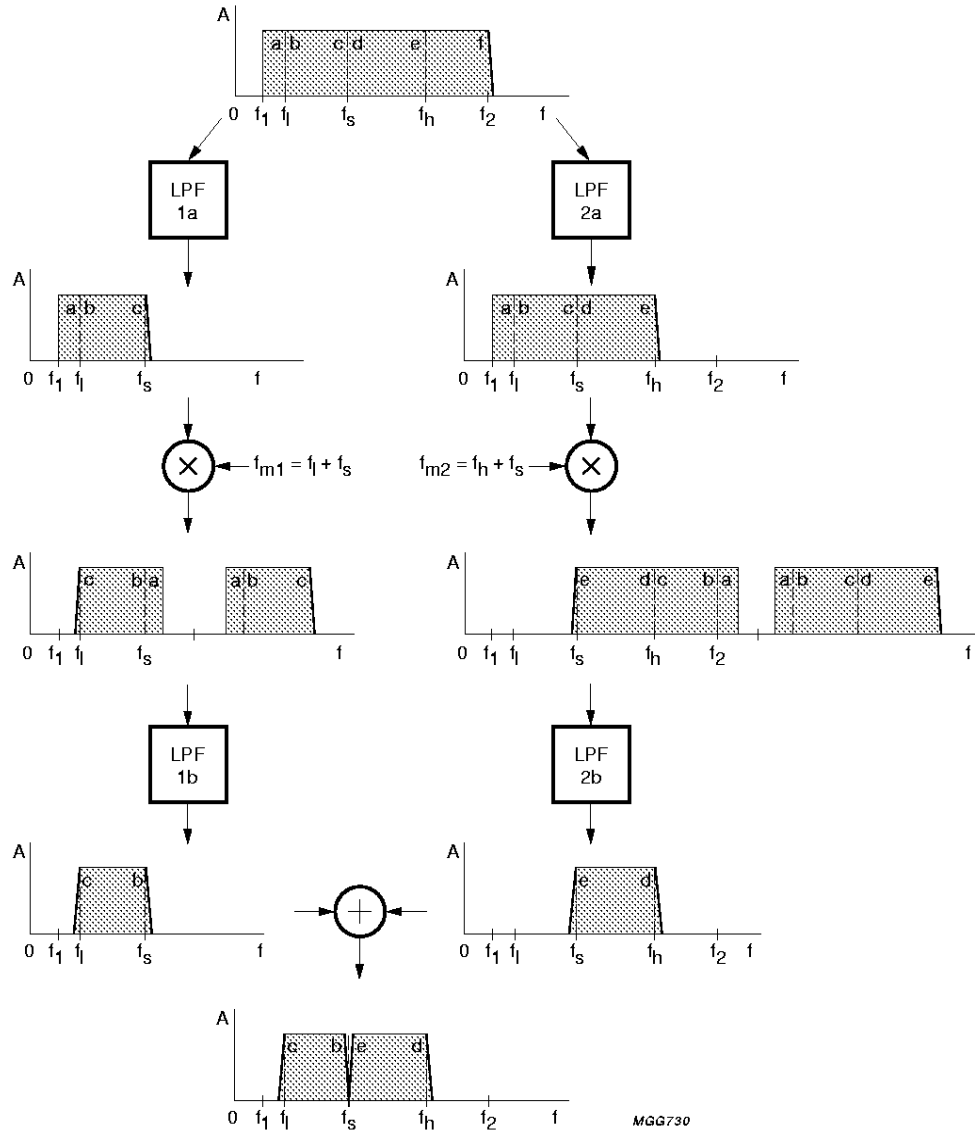

Fig.3 Scrambler signal path.

# Analog voice scrambler/descrambler

# PCD4440T

### 7.2 Power supply ( $V_{DD}$ , $V_{SS}$ )

The positive supply of the circuit ( $V_{DD}$ ) must meet the voltage requirement as indicated in the characteristics. To avoid undefined states of the device at power-on, an internal reset circuit clears the logic. The power-on reset has the highest priority; it blocks and resets the complete circuit.

### 7.3 Oscillator (OSCI)

The time base for the PCD4440T is a 3.58 MHz input signal which can be derived from the oscillator output (OSCO) of Philips microcontroller families PCD33xxA or PCF84CxxxA. Figure 4 shows the OSCI connection.

### 7.4 Splitting frequency and mode selection

Table 1 shows the input codes required to select the various splitting frequencies, and the mute, transparent and scramble/descramble modes. The codes form part of the serial I<sup>2</sup>C-bus message input on the SDA line from the microcontroller.

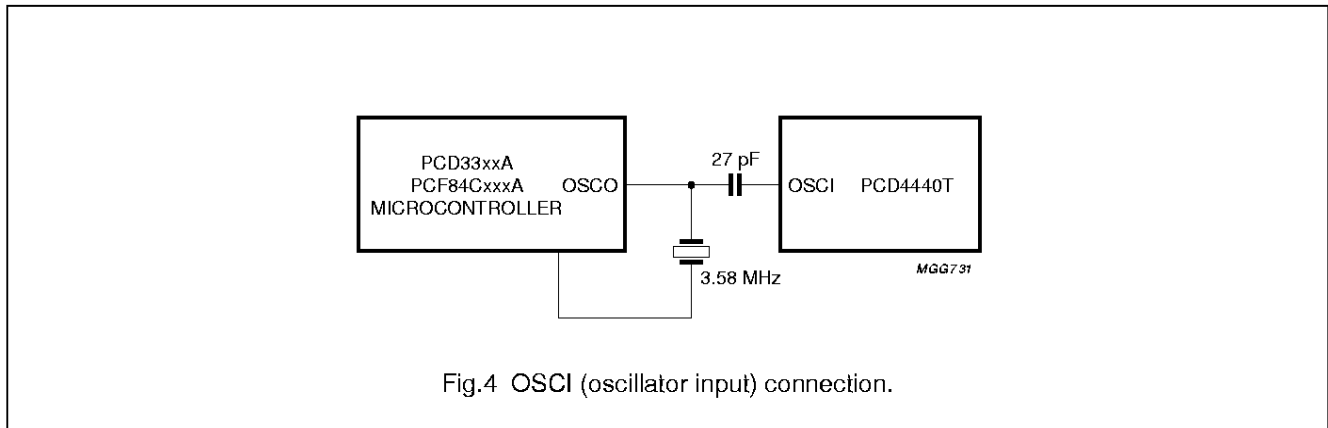

**Table 1** Input data codes for splitting frequency and mode selection; note 1

D3	D2	D1	D0	HEX	APPLICATION	$f_s^{(2)}$ (Hz)
0	0	0	1	01	Mute mode	–
0	0	1	0	02	Select $f_s$	2641
0	0	1	1	03	Select $f_s$	1853
0	1	0	0	04	Select $f_s$	1507
0	1	0	1	05	Select $f_s$	1279
0	1	1	0	06	Select $f_s$	1117
0	1	1	1	07	Select $f_s$	1018
1	0	0	0	08	Select $f_s$	899
1	0	0	1	09	Select $f_s$	837
1	0	1	0	0A	Select $f_s$	767
1	0	1	1	0B	Transparent mode	–
1	1	1	1	0F	Start scramble/descramble mode	–

**Notes**

- Input codes other than shown in the table are not allowed.
- Oscillator frequency = 3.58 MHz.

# Analog voice scrambler/descrambler

# PCD4440T

### 7.5 Serial clock input (SCL), Serial data input (SDA)

SCL and SDA are serial clock and data lines which conform to the I<sup>2</sup>C-bus specification. Both inputs must be pulled up externally to V<sub>DD</sub> through resistors of approximately 10 kΩ.

### 7.6 Address input (A0)

A0 is the slave address input and is used to set one bit of the slave address, so as to identify one of two PCD4440T devices connected to the same I<sup>2</sup>C-bus. Whether another PCD4440T is connected to the bus or not, A0 must be connected to V<sub>DD</sub> or V<sub>SS</sub>. The remaining bits of the slave address are fixed internally.

### 7.7 I<sup>2</sup>C-bus data configuration

The PCD4440T is always a slave receiver in the I<sup>2</sup>C-bus configuration (the R/W bit = 0). The slave address consists of 7 bits, where the least significant is set by the input on A0. The more significant bits are fixed internally, as shown in Fig.5. For definition of D0-D4, see Table 1.

### 7.8 Signal input (IN), Signal output (OUT)

Signal input for the scrambler/descrambler is coupled into a 'Sallen and Key' anti-aliasing filter configuration. A DC bias voltage of 1/2 V<sub>DD</sub> is built-in.

The analog signal output is buffered to achieve a relatively low output impedance of roughly 1 kΩ which is sufficient to drive the earpiece amplifier or similar applications.

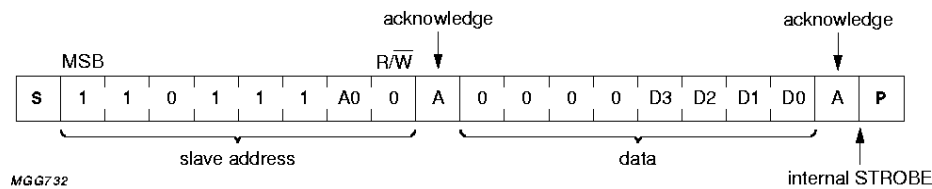

Fig.5 I<sup>2</sup>C-bus data format.



# Analog voice scrambler/descrambler

# PCD4440T

## 8 I<sup>2</sup>C BUS INTERFACE

The I<sup>2</sup>C-bus is for two-way communication between different ICs or modules. It uses only two lines, a serial data line (SDA) and a serial clock line (SCL), both of which are bi-directional. Both lines must be connected to a positive supply via a pull-up resistor when connected to the output stages of a device. Data transfer may be initiated only when the bus is not busy.

### 8.1 Bit transfer (see Fig.6)

One data bit is transferred during each clock pulse. The data on the SDA line must remain stable during the HIGH period of the clock pulse as changes in the data line at this time will be interpreted as control signals.

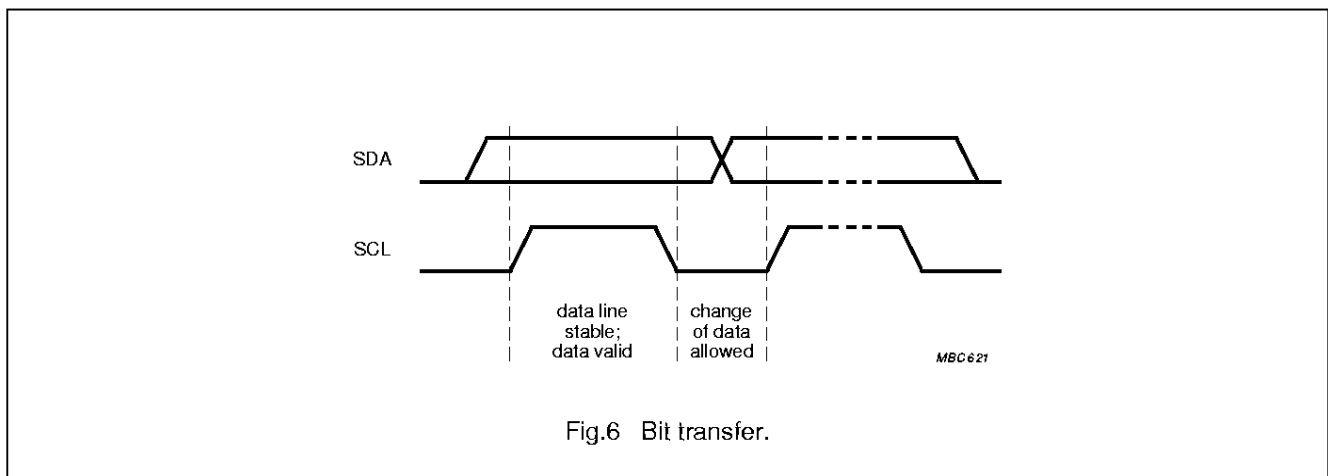

### 8.2 Start and stop conditions (see Fig.7)

Both data and clock lines remain HIGH when the bus is not busy. A HIGH-to-LOW transition of the data line, while the clock is HIGH is defined as the start condition (S). A LOW-to-HIGH transition of the data line while the clock is HIGH is defined as the stop condition (P).

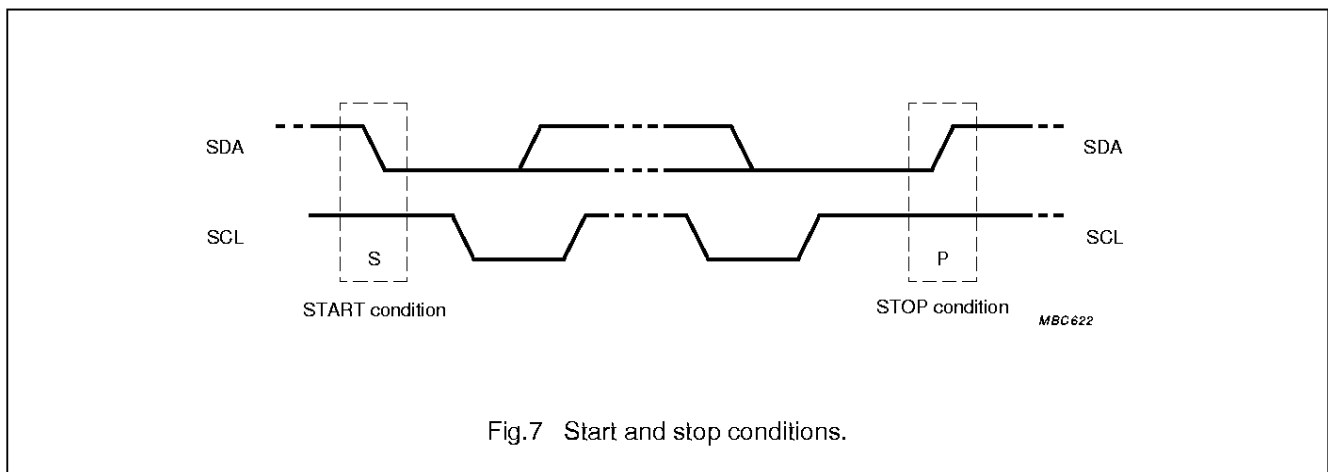

# Analog voice scrambler/descrambler

# PCD4440T

### 8.3 System configuration (see Fig.8)

A device generating a message is a 'transmitter', a device receiving a message is the 'receiver'. The device that controls message transfer is the 'master' and the devices that are controlled by the master are the 'slaves'.

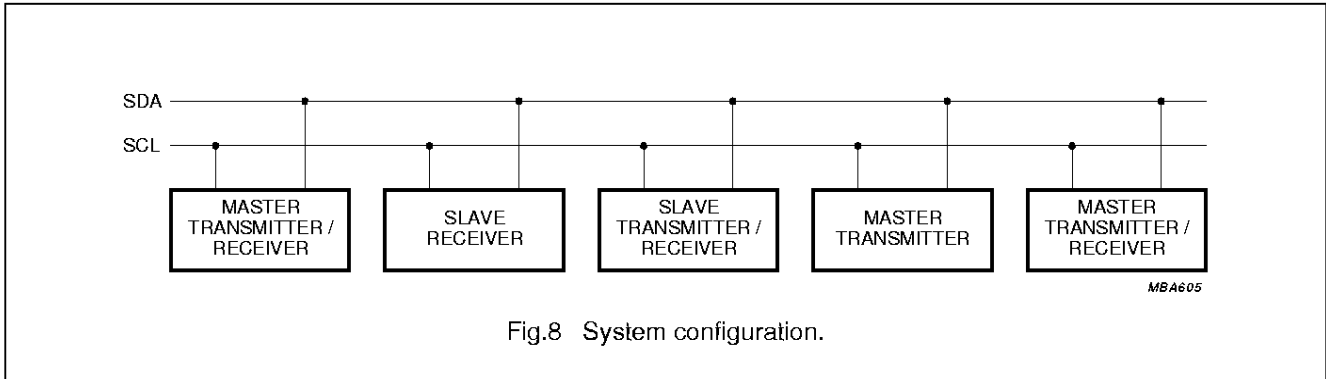

Fig.8 System configuration.

### 8.4 Acknowledge (see Fig.9)

The number of data bytes transferred between the start and stop conditions from transmitter to receiver is not limited. Each byte of eight bits is followed by one acknowledge bit. The acknowledge bit is a HIGH level put on the bus by the transmitter whereas the master generates an extra acknowledge after the reception of each byte. Also a master must generate an acknowledge after reception of each byte that has been clocked out of the slave transmitter. The device that acknowledges has to pull down the SDA line during the acknowledge-related clock pulse. Set-up and hold times must be taken into account to ensure that the SDA line is stable LOW during the whole high period of the acknowledge-related clock pulse. A master receiver must signal an end of data to the transmitter by **not** generating an acknowledge on the last byte that has been clocked out of the slave. In this event the transmitter must leave the data line HIGH to enable the master to generate the stop condition.

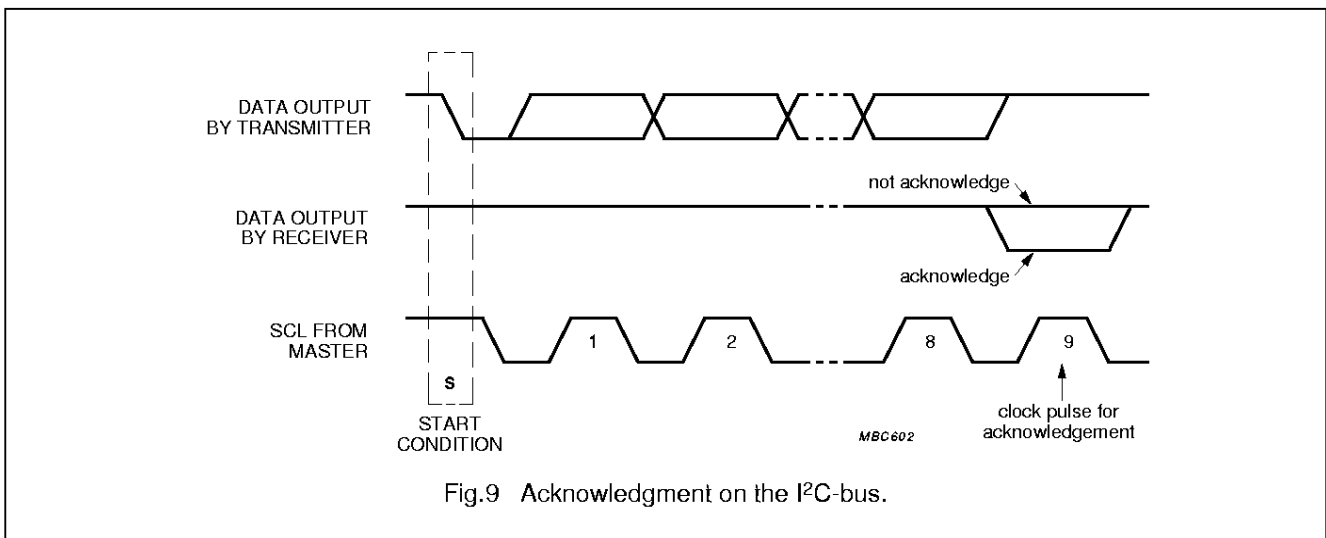

Fig.9 Acknowledgment on the I2C-bus.

# Analog voice scrambler/descrambler

# PCD4440T

## 8.5 Timing specifications

The PCD4440T accepts data input from a microcontroller and operates as a 'slave receiver' via the I<sup>2</sup>C-bus. It supports the 'standard' mode of the I<sup>2</sup>C-bus, but not the 'fast' mode detailed in "The I<sup>2</sup>C-bus and how to use it" document order no. 9398 393 40011. The timing requirement are as follows:

Masters generate a bus clock with a maximum frequency of 100 kHz. Detailed timing is shown in Fig. 10, where the two signal levels are LOW = V<sub>IL</sub> and HIGH = V<sub>IH</sub>, see Chapter 12. The time symbols are explained in Table 2. Figure 11 shows a complete data transfer.

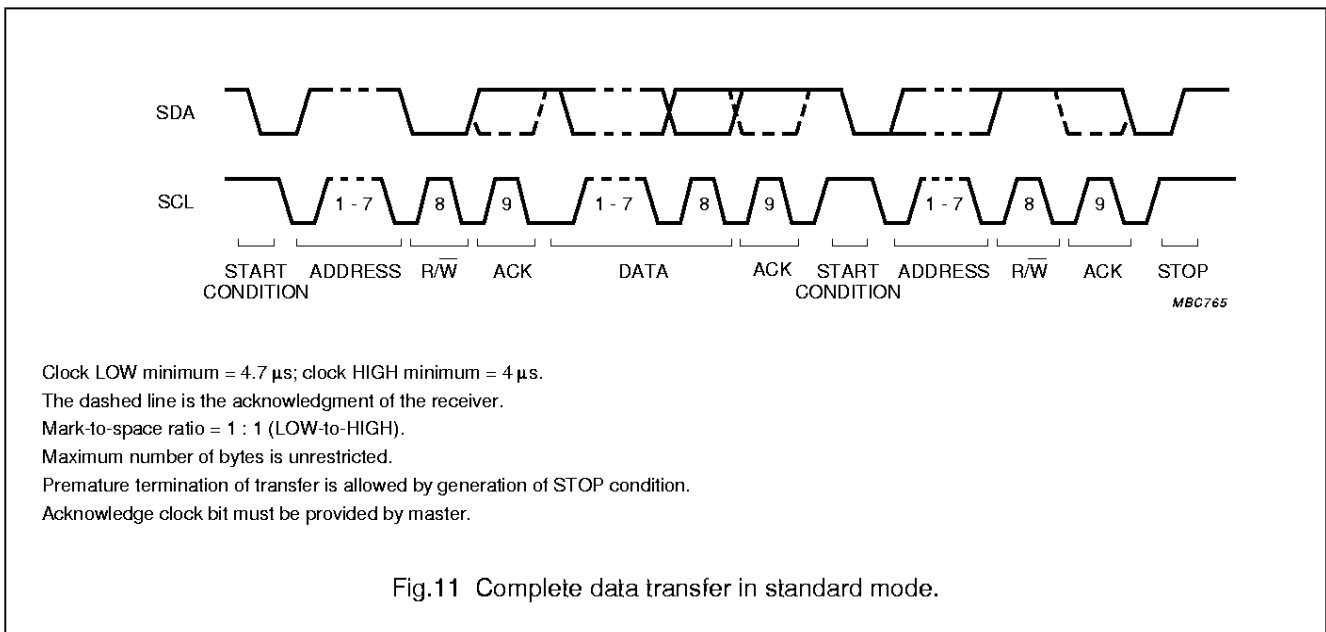
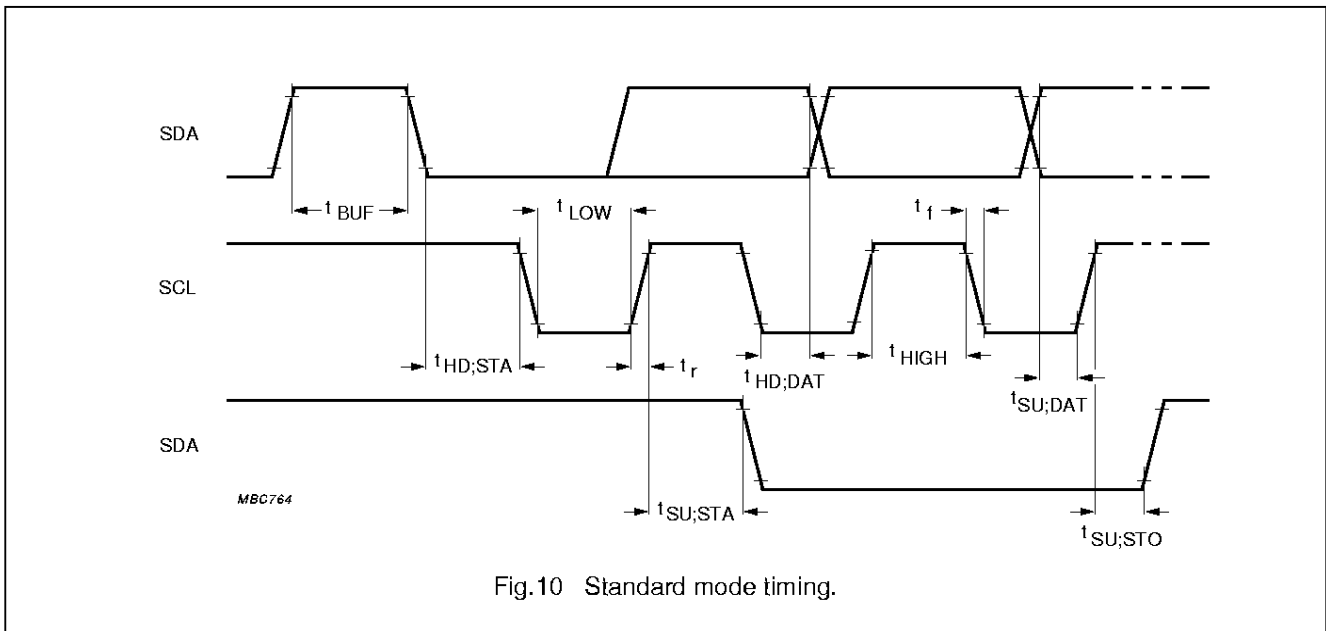

Clock LOW minimum = 4.7  $\mu$ s; clock HIGH minimum = 4  $\mu$ s.  
 The dashed line is the acknowledgment of the receiver.  
 Mark-to-space ratio = 1 : 1 (LOW-to-HIGH).  
 Maximum number of bytes is unrestricted.  
 Premature termination of transfer is allowed by generation of STOP condition.  
 Acknowledge clock bit must be provided by master.

## Analog voice scrambler/descrambler

## PCD4440T

**Table 2** Explanation of time symbols used in Fig.10

SYMBOL	PARAMETER	DESCRIPTION	MIN.	MAX.	UNITS
$f_{SCL}$	SCL clock frequency		0	100	kHz
$t_{SW}$	tolerable pulse spike width		–	100	ns
$t_{BUF}$	bus free time	The time that the bus is free (SDA is HIGH) before a new transmission is initiated by SDA going LOW.	4.7	–	$\mu$ s
$t_{SU;STA}$	set-up time repeated START	Only valid for repeated start code.	4.7	–	$\mu$ s
$t_{HD;STA}$	hold time START condition	The time between SDA going LOW and the first valid negative-going transition of SCL.	4.0	–	$\mu$ s
$t_{LOW}$	SCL LOW time	The LOW period of the SCL clock.	4.7	–	$\mu$ s
$t_{HIGH}$	SCL HIGH time	The HIGH period of the SCL clock.	4.0	–	$\mu$ s
$t_r$	rise time SDA and SCL		–	1.0	$\mu$ s
$t_f$	fall time SDA and SCL		–	0.3	$\mu$ s
$t_{SU;DAT}$	data set-up time		250	–	ns
$t_{HD;DAT}$	data hold time		0	–	ns
$t_{SU;STO}$	set-up time STOP condition		4.0	–	$\mu$ s

# Analog voice scrambler/descrambler

PCD4440T

## 9 APPLICATIONS

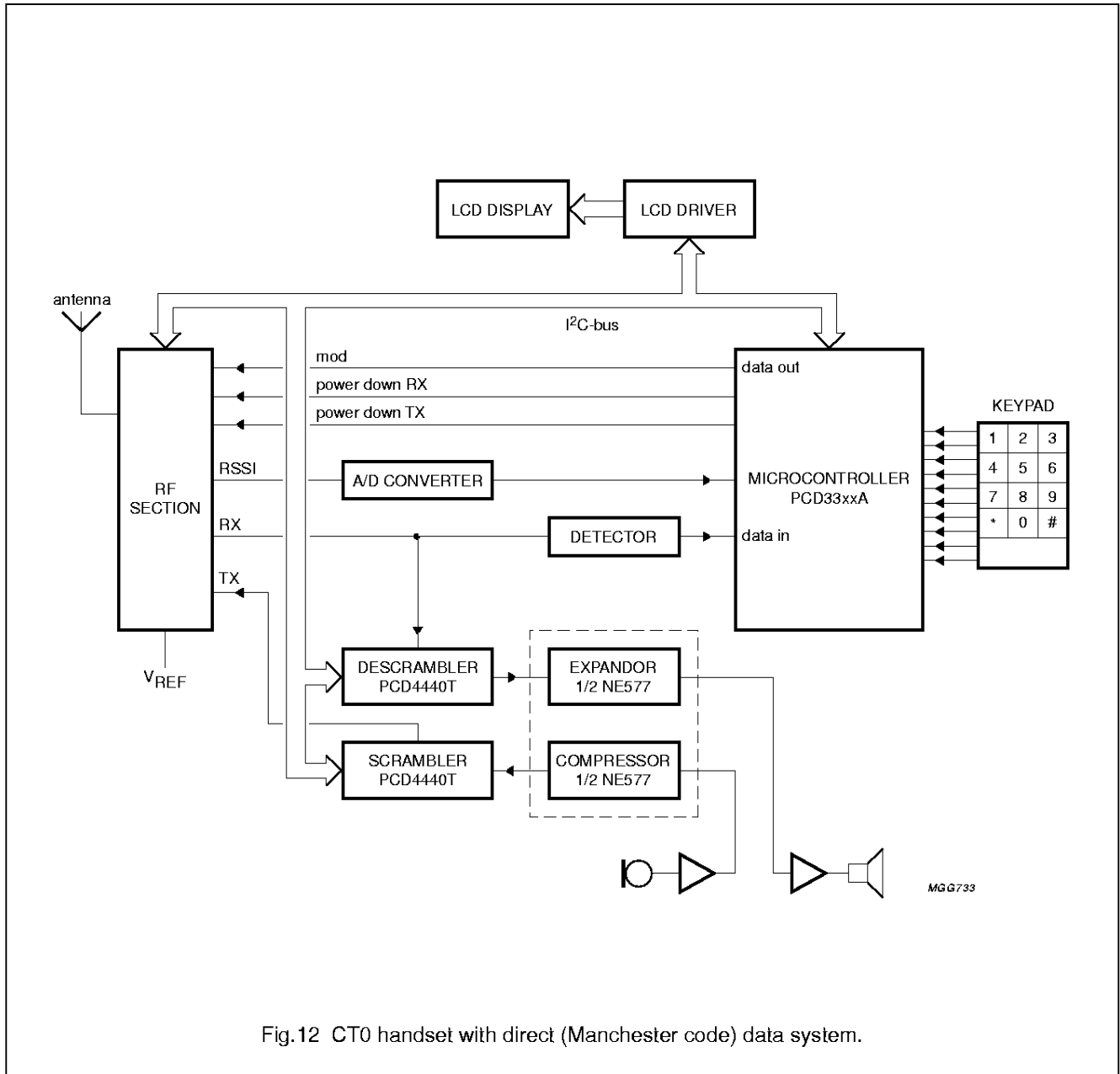

Analog voice scrambler/descrambler

PCD4440T

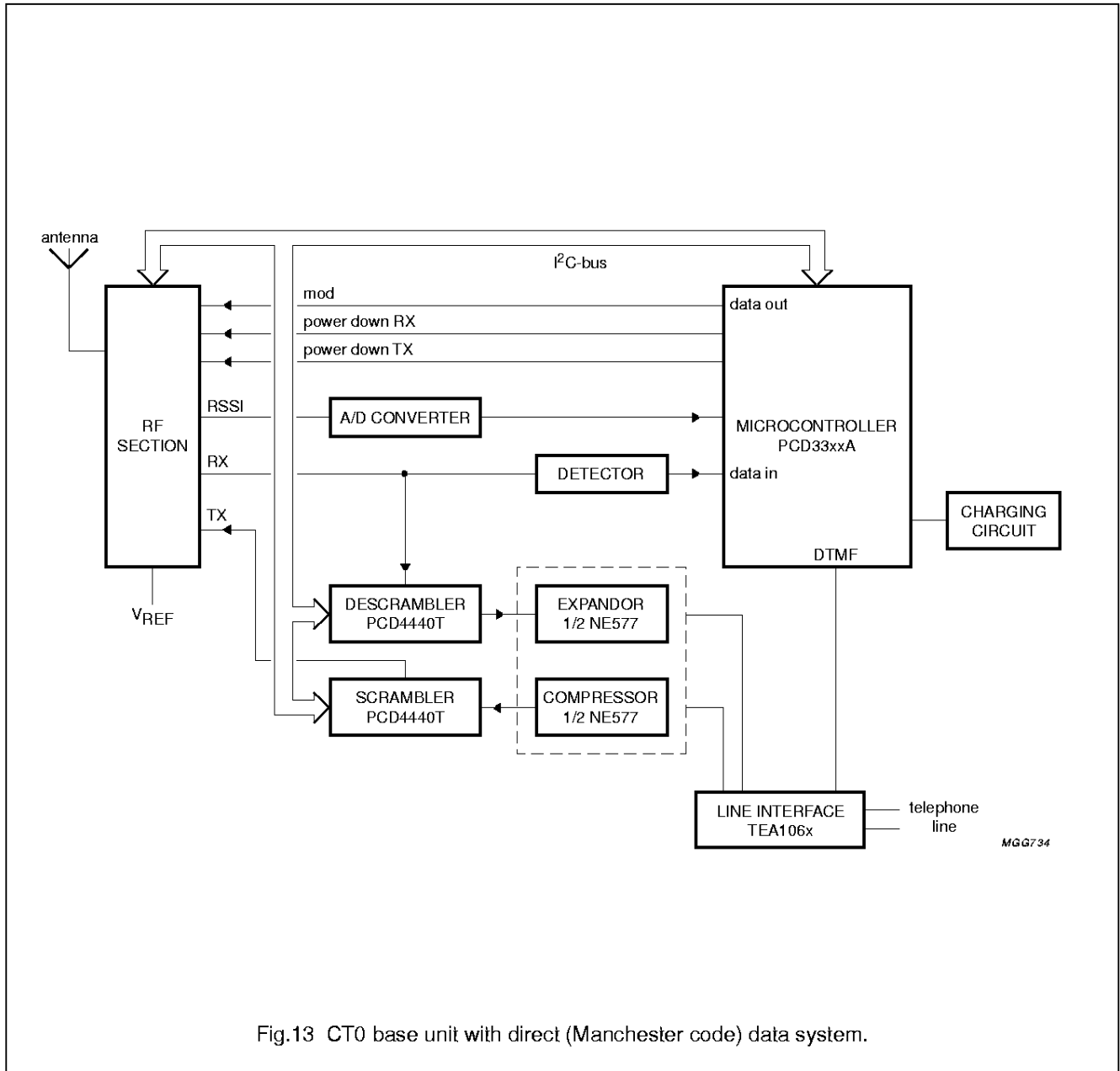

Fig.13 CT0 base unit with direct (Manchester code) data system.

10 HANDLING

Inputs and outputs are protected against electrostatic discharge in normal handling. However, it is good practice to take normal precautions appropriate to handling MOS devices (see "*Handbook IC03, Section General, Handling MOS devices*").

## Analog voice scrambler/descrambler

PCD4440T

**11 LIMITING VALUES**

In accordance with the Absolute Maximum Rating System (IEC 134).

SYMBOL	PARAMETER	MIN.	MAX.	UNIT
$V_{DD}$	supply voltage	-0.3	+7.0	V
$V_I$	all input voltages	-0.8	$V_{DD} + 0.8$	V
$I_I$	DC input current	-10	+10	mA
$I_O$	DC output current	-20	+20	mA
$P_{tot}$	total power dissipation	-	300	mW
$P_O$	power dissipation per output	-	50	mW
$T_{stg}$	storage temperature	-65	+150	°C
$T_{amb}$	operating ambient temperature	-25	+70	°C

**12 CHARACTERISTICS** $V_{DD} = 5.0$  V;  $V_{SS} = 0$  V;  $T_{amb} = 25$  °C; all voltages with respect to  $V_{SS}$ ;  $f_{xtal} = 3.579$  MHz unless otherwise specified.

SYMBOL	PARAMETER	CONDITIONS	MIN.	TYP.	MAX.	UNIT
<b>Supply</b>						
$V_{DD}$	operating supply voltage		2.8	-	6.0	V
$I_{DD}$	supply current					
	mute mode	$V_{DD} = 3$ V	-	2.2	-	mA
	operating mode	$V_{DD} = 3$ V	-	13	-	mA
<b>Inputs/Outputs: AO, SDA, SCL</b>						
$V_{IL}$	LOW level input voltage		0	-	$0.3V_{DD}$	V
$V_{IH}$	HIGH level input voltage		$0.7V_{DD}$	-	$V_{DD}$	V
$C_i$	input capacitance		-	-	7	pF
$I_{OL}$	SDA output current LOW	$V_{OL} = 0.4$ V	3.0	-	-	mA
<b>Signal input: IN</b>						
$V_{DC}$	DC voltage level		-	$0.5V_{DD}$	-	V
$V_{i(P-P)}$	allowed amplitude		-	1.25	$V_{DD} - 1$	V
$ Z_i $	input impedance	frequency = 1 kHz	-	120	-	k $\Omega$
<b>Signal output: OUT</b>						
$V_{DC}$	DC voltage level		-	$0.5V_{DD}$	-	V
$ Z_o $	output impedance	frequency = 1 kHz	-	-	1	k $\Omega$
UFS	unwanted frequency suppression	$V_{i(P-P)} = 1.25$ V; $f_S = 767$ or $2461$ Hz; $f_{in} = 1$ kHz; $V_{DD} = 3$ V or $5$ V	35	40	-	dB
$V_o/V_i$	transfer loss	transparent mode	-	3.5	-	dB
		operating mode	-	0	-	dB
<b>Oscillator frequency input: OSCI</b>						
$V_{DC}$	DC voltage level		-	$0.5V_{DD}$	-	V
$V_{IL}$	LOW level input voltage		0	-	$0.3V_{DD}$	V
$V_{IH}$	HIGH level input voltage		$0.7V_{DD}$	-	$V_{DD}$	V

Analog voice scrambler/descrambler

PCD4440T

13 PACKAGE OUTLINE

SO8: plastic small outline package; 8 leads; body width 7.5 mm

SOT176-1

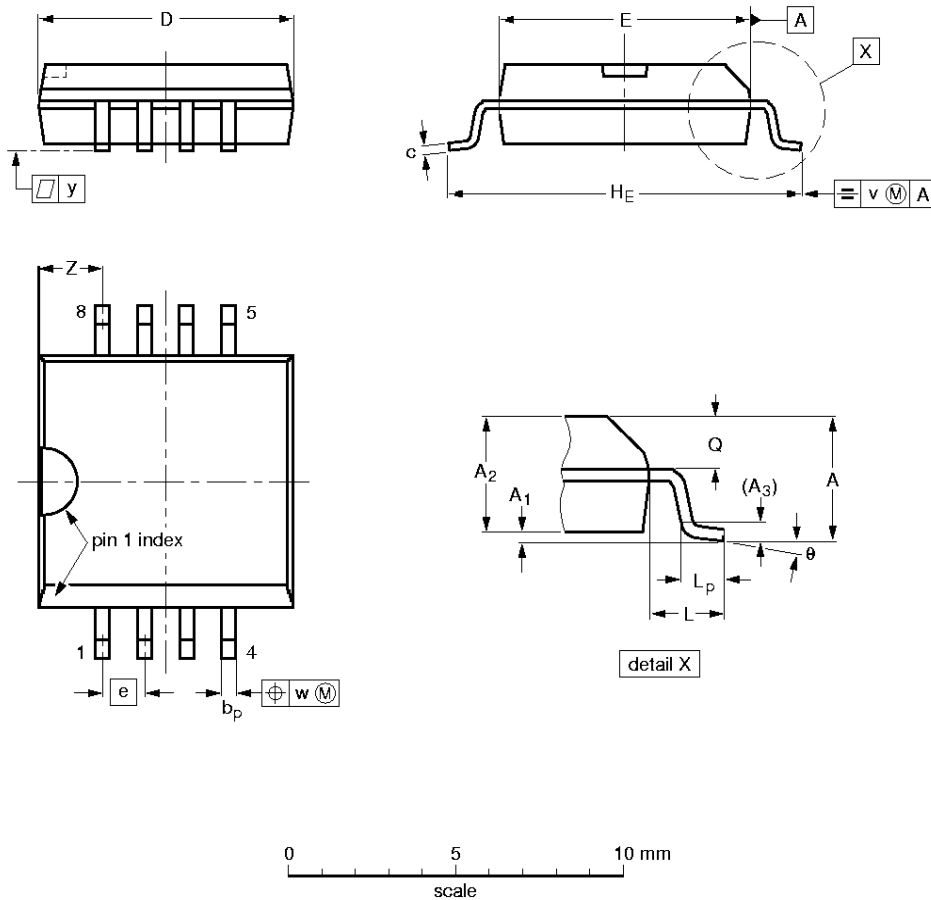

DIMENSIONS (inch dimensions are derived from the original mm dimensions)

UNIT	A max.	A <sub>1</sub>	A <sub>2</sub>	A <sub>3</sub>	b <sub>p</sub>	c	D <sup>(1)</sup>	E <sup>(1)</sup>	e	H <sub>E</sub>	L	L <sub>p</sub>	Q	v	w	y	z <sup>(1)</sup>	θ
mm	2.65	0.3 0.1	2.45 2.25	0.25	0.49 0.36	0.32 0.23	7.65 7.45	7.6 7.4	1.27	10.65 10.00	1.45	1.1 0.45	1.1 1.0	0.25	0.25	0.1	2.0 1.8	8° 0°
inches	0.10	0.012 0.004	0.096 0.089	0.01	0.019 0.014	0.013 0.009	0.30 0.29	0.30 0.29	0.050	0.42 0.39	0.057	0.043 0.018	0.043 0.039	0.01	0.01	0.004	0.079 0.071	

Note

1. Plastic or metal protrusions of 0.15 mm maximum per side are not included.

OUTLINE VERSION	REFERENCES				EUROPEAN PROJECTION	ISSUE DATE
	IEC	JEDEC	EIAJ			
SOT176-1						91-08-13 95-02-25



---

## Analog voice scrambler/descrambler

PCD4440T

---

### 14 SOLDERING

#### 14.1 Introduction

There is no soldering method that is ideal for all IC packages. Wave soldering is often preferred when through-hole and surface mounted components are mixed on one printed-circuit board. However, wave soldering is not always suitable for surface mounted ICs, or for printed-circuits with high population densities. In these situations reflow soldering is often used.

This text gives a very brief insight to a complex technology. A more in-depth account of soldering ICs can be found in our "*IC Package Databook*" (order code 9398 652 90011).

#### 14.2 Reflow soldering

Reflow soldering techniques are suitable for all SO packages.

Reflow soldering requires solder paste (a suspension of fine solder particles, flux and binding agent) to be applied to the printed-circuit board by screen printing, stencilling or pressure-syringe dispensing before package placement.

Several techniques exist for reflowing; for example, thermal conduction by heated belt. Dwell times vary between 50 and 300 seconds depending on heating method. Typical reflow temperatures range from 215 to 250 °C.

Preheating is necessary to dry the paste and evaporate the binding agent. Preheating duration: 45 minutes at 45 °C.

#### 14.3 Wave soldering

Wave soldering techniques can be used for all SO packages if the following conditions are observed:

- A double-wave (a turbulent wave with high upward pressure followed by a smooth laminar wave) soldering technique should be used.
- The longitudinal axis of the package footprint must be parallel to the solder flow.
- The package footprint must incorporate solder thieves at the downstream end.

During placement and before soldering, the package must be fixed with a droplet of adhesive. The adhesive can be applied by screen printing, pin transfer or syringe dispensing. The package can be soldered after the adhesive is cured.

Maximum permissible solder temperature is 260 °C, and maximum duration of package immersion in solder is 10 seconds, if cooled to less than 150 °C within 6 seconds. Typical dwell time is 4 seconds at 250 °C.

A mildly-activated flux will eliminate the need for removal of corrosive residues in most applications.

#### 14.4 Repairing soldered joints

Fix the component by first soldering two diagonally-opposite end leads. Use only a low voltage soldering iron (less than 24 V) applied to the flat part of the lead. Contact time must be limited to 10 seconds at up to 300 °C. When using a dedicated tool, all other leads can be soldered in one operation within 2 to 5 seconds between 270 and 320 °C.

Analog voice scrambler/descrambler

PCD4440T

**15 DEFINITIONS**

<b>Data sheet status</b>	
Objective specification	This data sheet contains target or goal specifications for product development.
Preliminary specification	This data sheet contains preliminary data; supplementary data may be published later.
Product specification	This data sheet contains final product specifications.
<b>Limiting values</b>	
Limiting values given are in accordance with the Absolute Maximum Rating System (IEC 134). Stress above one or more of the limiting values may cause permanent damage to the device. These are stress ratings only and operation of the device at these or at any other conditions above those given in the Characteristics sections of the specification is not implied. Exposure to limiting values for extended periods may affect device reliability.	
<b>Application information</b>	
Where application information is given, it is advisory and does not form part of the specification.	

**16 LIFE SUPPORT APPLICATIONS**

These products are not designed for use in life support appliances, devices, or systems where malfunction of these products can reasonably be expected to result in personal injury. Philips customers using or selling these products for use in such applications do so at their own risk and agree to fully indemnify Philips for any damages resulting from such improper use or sale.

**17 PURCHASE OF PHILIPS I<sup>2</sup>C COMPONENTS**

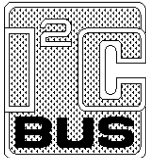

Purchase of Philips I<sup>2</sup>C components conveys a license under the Philips' I<sup>2</sup>C patent to use the components in the I<sup>2</sup>C system provided the system conforms to the I<sup>2</sup>C specification defined by Philips. This specification can be ordered using the code 9398 393 40011.

Analog voice scrambler/descrambler

PCD4440T

---

**NOTES**

# Philips Semiconductors – a worldwide company

**Argentina:** see South America

**Australia:** 34 Waterloo Road, NORTH RYDE, NSW 2113,  
Tel. +61 2 9805 4455, Fax. +61 2 9805 4466

**Austria:** Computerstr. 6, A-1101 WIEN, P.O. Box 213,  
Tel. +43 1 60 101, Fax. +43 1 60 101 1210

**Belarus:** Hotel Minsk Business Center, Bld. 3, r. 1211, Volodarski Str. 6,  
220050 MINSK, Tel. +375 172 200 733, Fax. +375 172 200 773

**Belgium:** see The Netherlands

**Brazil:** see South America

**Bulgaria:** Philips Bulgaria Ltd., Energoproject, 15th floor,  
51 James Bourchier Blvd., 1407 SOFIA,  
Tel. +359 2 689 211, Fax. +359 2 689 102

**Canada:** PHILIPS SEMICONDUCTORS/COMPONENTS,  
Tel. +1 800 234 7381

**China/Hong Kong:** 501 Hong Kong Industrial Technology Centre,  
72 Tat Chee Avenue, Kowloon Tong, HONG KONG,  
Tel. +852 2319 7888, Fax. +852 2319 7700

**Colombia:** see South America

**Czech Republic:** see Austria

**Denmark:** Prags Boulevard 80, PB 1919, DK-2300 COPENHAGEN S,  
Tel. +45 32 88 2636, Fax. +45 31 57 1949

**Finland:** Sinikalliontie 3, FIN-02630 ESPOO,  
Tel. +358 9 615800, Fax. +358 9 61580/xxx

**France:** 4 Rue du Port-aux-Vins, BP317, 92156 SURESNES Cedex,  
Tel. +33 1 40 99 6161, Fax. +33 1 40 99 6427

**Germany:** Hammerbrookstraße 69, D-20097 HAMBURG,  
Tel. +49 40 23 53 60, Fax. +49 40 23 536 300

**Greece:** No. 15, 25th March Street, GR 17778 TAVROS/ATHENS,  
Tel. +30 1 4894 339/239, Fax. +30 1 4814 240

**Hungary:** see Austria

**India:** Philips INDIA Ltd, Shivsagar Estate, A Block, Dr. Annie Besant Rd.  
Worli, MUMBAI 400 018, Tel. +91 22 4938 541, Fax. +91 22 4938 722

**Indonesia:** see Singapore

**Ireland:** Newstead, Clonskeagh, DUBLIN 14,  
Tel. +353 1 7640 000, Fax. +353 1 7640 200

**Israel:** RAPAC Electronics, 7 Kehilat Saloniki St, TEL AVIV 61180,  
Tel. +972 3 645 0444, Fax. +972 3 649 1007

**Italy:** PHILIPS SEMICONDUCTORS, Piazza IV Novembre 3,  
20124 MILANO, Tel. +39 2 6752 2531, Fax. +39 2 6752 2557

**Japan:** Philips Bldg 13-37, Kohnan 2-chome, Minato-ku, TOKYO 108,  
Tel. +81 3 3740 5130, Fax. +81 3 3740 5077

**Korea:** Philips House, 260-199 Itaewon-dong, Yongsan-ku, SEOUL,  
Tel. +82 2 709 1412, Fax. +82 2 709 1415

**Malaysia:** No. 76 Jalan Universiti, 46200 PETALING JAYA, SELANGOR,  
Tel. +60 3 750 5214, Fax. +60 3 757 4880

**Mexico:** 5900 Gateway East, Suite 200, EL PASO, TEXAS 79905,  
Tel. +9-5 800 234 7381

**Middle East:** see Italy

**Netherlands:** Postbus 90050, 5600 PB EINDHOVEN, Bldg. VB,  
Tel. +31 40 27 82785, Fax. +31 40 27 88399

**New Zealand:** 2 Wagener Place, C.P.O. Box 1041, AUCKLAND,  
Tel. +64 9 849 4160, Fax. +64 9 849 7811

**Norway:** Box 1, Manglerud 0612, OSLO,  
Tel. +47 22 74 8000, Fax. +47 22 74 8341

**Philippines:** Philips Semiconductors Philippines Inc.,  
106 Valero St. Salcedo Village, P.O. Box 2108 MCC, MAKATI,  
Metro MANILA, Tel. +63 2 816 6380, Fax. +63 2 817 3474

**Poland:** Ul. Lukiska 10, PL 04-123 WARSZAWA,  
Tel. +48 22 612 2831, Fax. +48 22 612 2327

**Portugal:** see Spain

**Romania:** see Italy

**Russia:** Philips Russia, Ul. Usatcheva 35A, 119048 MOSCOW,  
Tel. +7 095 247 9145, Fax. +7 095 247 9144

**Singapore:** Lorong 1, Toa Payoh, SINGAPORE 1231,  
Tel. +65 350 2538, Fax. +65 251 6500

**Slovakia:** see Austria

**Slovenia:** see Italy

**South Africa:** S.A. PHILIPS Pty Ltd., 195-215 Main Road Martindale,  
2092 JOHANNESBURG, P.O. Box 7430 Johannesburg 2000,  
Tel. +27 11 470 5911, Fax. +27 11 470 5494

**South America:** Rua do Rocio 220, 5th floor, Suite 51,  
04552-903 São Paulo, SÃO PAULO - SP, Brazil,  
Tel. +55 11 821 2333, Fax. +55 11 829 1849

**Spain:** Balmes 22, 08007 BARCELONA,  
Tel. +34 3 301 6312, Fax. +34 3 301 4107

**Sweden:** Kottbygatan 7, Akalla, S-16485 STOCKHOLM,  
Tel. +46 8 632 2000, Fax. +46 8 632 2745

**Switzerland:** Allmendstrasse 140, CH-8027 ZÜRICH,  
Tel. +41 1 488 2686, Fax. +41 1 481 7730

**Taiwan:** PHILIPS TAIWAN Ltd., 23-30F, 66,  
Chung Hsiao West Road, Sec. 1, P.O. Box 22978,  
TAIPEI 100, Tel. +886 2 382 4443, Fax. +886 2 382 4444

**Thailand:** PHILIPS ELECTRONICS (THAILAND) Ltd.,  
209/2 Sanpavuth-Bangna Road Prakanong, BANGKOK 10260,  
Tel. +66 2 745 4090, Fax. +66 2 398 0793

**Turkey:** Talatpasa Cad. No. 5, 80640 GÜLTEPE/ISTANBUL,  
Tel. +90 212 279 2770, Fax. +90 212 282 6707

**Ukraine:** PHILIPS UKRAINE, 4 Patrice Lumumba str., Building B, Floor 7,  
252042 KIEV, Tel. +380 44 264 2776, Fax. +380 44 268 0461

**United Kingdom:** Philips Semiconductors Ltd., 276 Bath Road, Hayes,  
MIDDLESEX UB3 5BX, Tel. +44 181 730 5000, Fax. +44 181 754 8421

**United States:** 811 East Arques Avenue, SUNNYVALE, CA 94088-3409,  
Tel. +1 800 234 7381

**Uruguay:** see South America

**Vietnam:** see Singapore

**Yugoslavia:** PHILIPS, Trg N. Pasica 5/v, 11000 BEOGRAD,  
Tel. +381 11 625 344, Fax. +381 11 635 777

For all other countries apply to: Philips Semiconductors, Marketing & Sales Communications,  
Building BE-p, P.O. Box 218, 5600 MD EINDHOVEN, The Netherlands, Fax. +31 40 27 24825

Internet: <http://www.semiconductors.philips.com>

© Philips Electronics N.V. 1996

SCA52

All rights are reserved. Reproduction in whole or in part is prohibited without the prior written consent of the copyright owner.

The information presented in this document does not form part of any quotation or contract, is believed to be accurate and reliable and may be changed without notice. No liability will be accepted by the publisher for any consequence of its use. Publication thereof does not convey nor imply any license under patent- or other industrial or intellectual property rights.

Printed in The Netherlands

417021/1200/02/pp20

Date of release: 1996 Dec 20

Document order number: 9397 750 01604

*Let's make things better.*

**Philips**  
**Semiconductors**



**PHILIPS**