

66124

**TWO CHANNEL, HERMETICALLY SEALED 20 PIN LCC
ELECTRICALLY SIMILAR TO 6N140**

Mii
OPTOELECTRONIC
PRODUCTS
DIVISION

Features:

- DSCC Approved 89785022X
- High current transfer ratio: 1000% typical
- 1500 Vdc isolation test voltage
- Low input current requirement: 0.5mA
- Low power consumption
- High radiation immunity
- Faraday shield to provide high common mode rejection

Applications:

- Military and Space
- High reliability systems
- Voltage Level Shifting
- Isolated Receiver Input
- Communication systems
- Medical systems

DESCRIPTION

The **66124** optocoupler consists of two infrared LEDs optically coupled to two corresponding high gain darlington detectors. This unique quad optocoupler provides high CTR and low leakage currents over the full military temperature range (-55° to +125°C). The 66124 is a 20pin leadless chip carrier hermetically sealed package and is available in standard and screened versions or tested to customer specifications. MIL-PRF-38534.

ABSOLUTE MAXIMUM RATINGS

(No derating required up to 125°C)

Storage Temperature.....	-65°C to +150°C
Operating Free-Air Temperature Range	-55°C to +125°C
Lead Solder Temperature.....	260°C for 10s (1.6mm below seating plane)
Peak Forward Input Current	40mA (1ms duration)
Average Forward Input Current	20mA
Input Power Dissipation	35mW
Reverse Input Voltage	5V
Supply Voltage - V_{CC}	7V(1 minute maximum)
Output Current - I_O	25mA
Output Power Dissipation	40mW
Output Voltage - V_O	7V
Total Power Dissipation	350mW

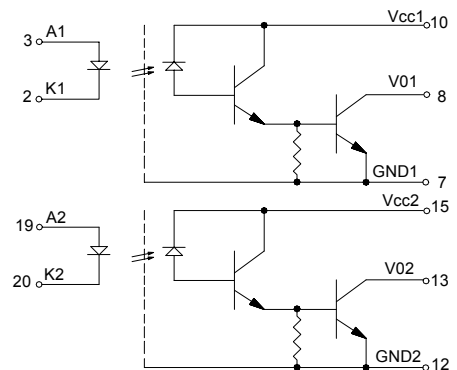
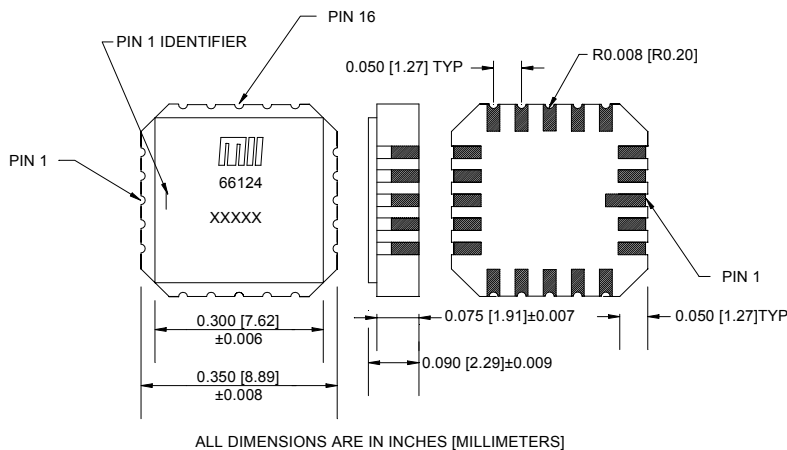
Package Dimensions**Schematic Diagram**

ELECTRICAL CHARACTERISTICST_a = -55°C to 125°C unless otherwise specified.

PARAMETER	SYMBOL	MIN	TYP	MAX	UNITS	TEST CONDITIONS	NOTE
Current Transfer Ratio	CTR	300	1000		%	I _F = 0.5mA, V _O = 0.4V, V _{CC} = 4.5V	1,2
		300	750		%	I _F = 1.6mA, V _O = 0.4V, V _{CC} = 4.5V	1,2
		200	400		%	I _F = 5.0mA, V _O = 0.4V, V _{CC} = 4.5V	1,2
Logic Low Output Voltage	V _{OL}		0.2	0.4	V	I _F = 0.5mA, I _{OL} = 1.5mA, V _{CC} = 4.5V	1
			0.1	0.4	V	I _F = 1.6mA, I _{OL} = 4.8mA, V _{CC} = 4.5V	
			0.1	0.4	V	I _F = 5.0mA, I _{OL} = 10mA, V _{CC} = 4.5V	
Logic High Output Current	I _{OH}		.005	250	μA	I _F = 2μA, V _O = V _{CC} = 18V	1,3
High Level Output Current	I _{CCH}		.010	20	μA	I _{F1} = I _{F2} = 0mA, V _{CC} = 18V	
Low Level Supply Current	I _{CCL}		1	2	mA	I _{F1} = I _{F2} = 1.6mA, V _{CC} = 18V	
Input Forward Voltage	V _F		1.4	1.8	V	I _F = 1.6mA	1
Input Reverse Breakdown Voltage	BV _R	5			V	I _R = 10μA	1
Input-Output Insulation Leakage Current	I _{L-O}			1.0	μA	V _{L-O} = 1500Vdc, Relative Humidity = 45% t _A = 25°C, t = 5s	4
Propagation Delay Time To High Output Level	t _{PLH}			60	μs	I _F = 0.5mA, V _{CC} = 5.0V, R _L = 4.7kΩ	
				50	μs	I _F = 1.6mA, V _{CC} = 5.0V, R _L = 1.5kΩ	
				30	μs	I _F = 5mA, V _{CC} = 5.0V, R _L = 680Ω	
Propagation Delay Time To Low Output Level	t _{PHL}			100	μs	I _F = 0.5mA, V _{CC} = 5.0V, R _L = 4.7kΩ	
				30	μs	I _F = 1.6mA, V _{CC} = 5.0V, R _L = 1.5kΩ	
				10	μs	I _F = 5mA, V _{CC} = 5.0V, R _L = 680Ω	

TYPICAL CHARACTERISTICST_a = 25°C, V_{CC} = 5V Each Channel

PARAMETER	SYMBOL	MIN	TYP	MAX	UNITS	TEST CONDITIONS	NOTE
Capacitance (Input-Output)	C _{I-O}		1.5		pF	f = 1MHz, t _a = 25°C	1, 4
Resistance (Input-Output)	R _{I-O}		10 ¹²		Ω	V _{L-O} = 500V, t _a = 25°C	1, 4
Common Mode Transient immunity at High Output Level	CM _H	500	1000		V/μs	V _{CM} = 50V P-P, V _{CC} = 5.0V, R _L = 1.5kΩ, I _F = 0mA t _a = 25°C	5
Common Mode Transient Immunity at Low Output Level	CM _L	500	1000		V/μs	V _{CM} = 50V P-P, V _{CC} = 5.0V, R _L = 1.5kΩ, I _F = 1.6mA t _a = 25°C	6

NOTES:

- Each channel.
- CURRENT TRANSFER RATIO is defined as the ratio of output collector current, I_O, to the forward LED input current, I_F, times 100%.
- I_F = 2μA for channel under test. For all other channels, I_F = 10mA.
- Measured with input pins shorted together and output pins shorted together.
- CM_H is the maximum tolerable common mode transient to assure that the output will remain in a high logic state (ie. V_O > @.0V).
- CM_L is the maximum tolerable common mode transient to assure that the output will remain in a low logic state (ie. V_O < 0.8V).

RECOMMENDED OPERATING CONDITIONS:

PARAMETER	SYMBOL	MIN	MAX	UNITS
Input Current, Low Level	I _{FL}	0	2	μA
Input Current, High Level	I _{FH}	0.5	5	mA
Supply Voltage	V _{CC}	2.0	18	V