

AN5295NK

3-ch. sound signal processing single chip IC for TV (with I²C bus)

■ Overview

The AN5295NK is a television-use 3-ch. sound signal processing IC which incorporates volume, tone control (L/R/C 3-ch.), and surround sound, sound AGC, lower sound enforce (L/R 2-ch.) functions. All of the functions (including changeover switch) including external I/O port can be controlled by I²C bus.

■ Features

- 3-ch. of volumes can be controlled independently (max. attenuation is 75 dB or more)
- Center output can be switched, either center input or inside L+R signal (for HDTV)
- Lower sound enforce effect (frequency and gain) can be adjusted with external parts
- With L+R output

■ Applications

- Television

■ Block Diagram

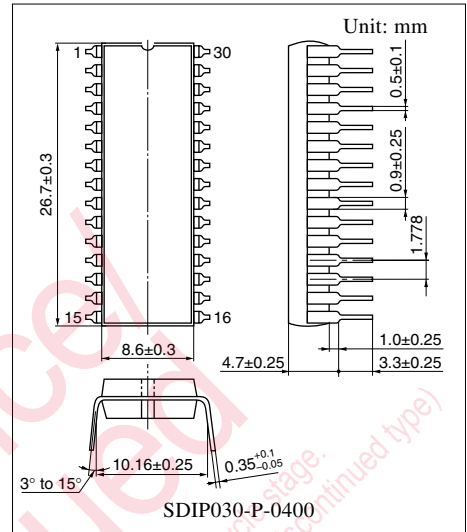
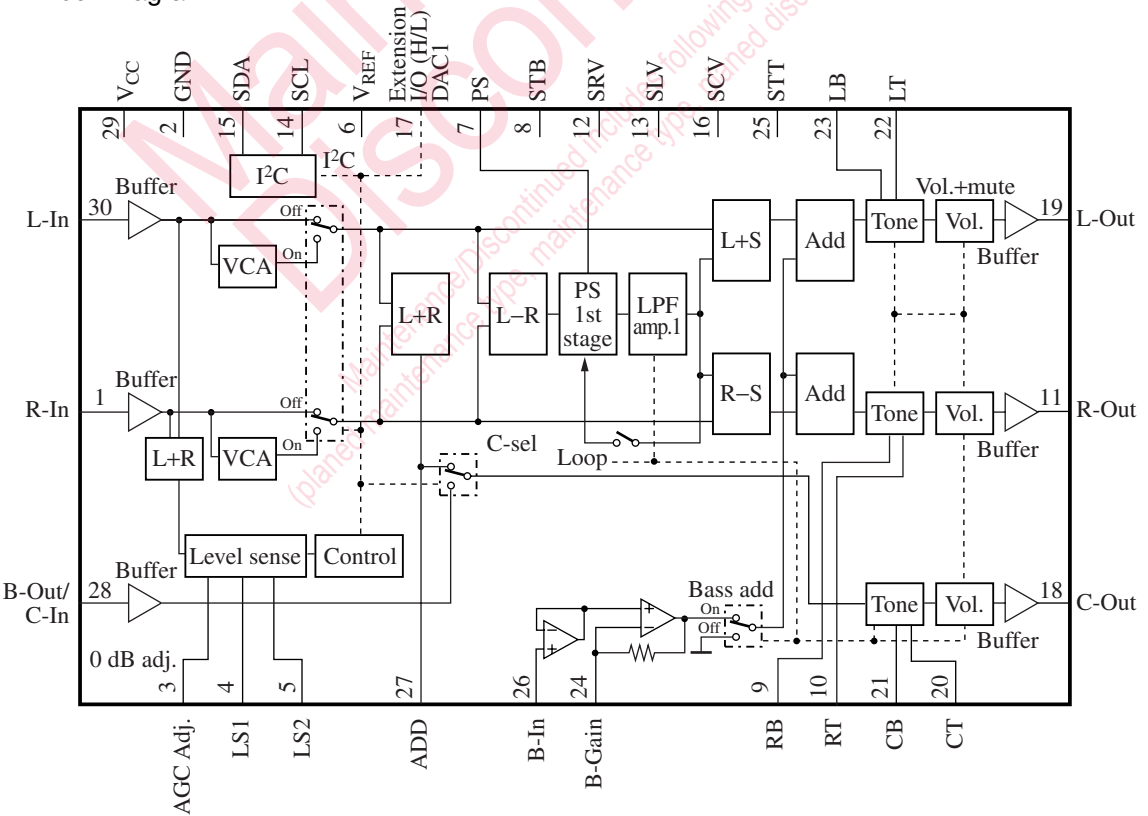

Note) The package of this product will be changed to lead-free type (SDIP30-P-0400B). See the new package dimensions section later of this datasheet.

■ Pin Descriptions

Pin No.	Description	Pin No.	Description
1	R-ch. input pin	16	C-ch. volume DAC output pin
2	Ground pin	17	Extension DAC pin 1
3	AGC 0 dB adjustment pin	18	C-ch. output pin
4	AGC level sensor-1 pin	19	L-ch. output pin
5	AGC level sensor-2 pin	20	C-ch. treble f_C setting pin
6	$1/2 V_{CC}$ pin	21	C-ch. bass f_C setting pin
7	Phase shift pin	22	L-ch. treble f_C setting pin
8	L/R/C-ch. bass DAC output pin	23	L-ch. bass f_C setting pin
9	R-ch. bass f_C setting pin	24	Bass mix. gain adjustment pin
10	R-ch. treble f_C setting pin	25	L/R/C-ch. treble DAC output pin
11	R-ch. output pin	26	Bass detection LPF ope.-amp. input pin
12	R-ch. volume DAC output pin	27	L+R add after AGC output pin
13	L-ch. volume DAC output pin	28	C-ch. input pin
14	I ² C communication clock pin	29	Power supply pin (12 V)
15	I ² C communication data pin	30	L-ch. input pin

■ Absolute Maximum Ratings

Parameter	Symbol	Rating	Unit
Supply voltage	V_{CC}	13.5	V
Supply current	I_{CC}	80	mA
Power dissipation *2	P_D	1 143	mW
Operating ambient temperature *1	T_{opr}	-20 to +75	°C
Storage temperature *1	T_{stg}	-55 to +150	°C

Note) *1: Except for the operating ambient temperature and storage temperature, all ratings are for $T_a = 25^\circ\text{C}$.

*2: $T_a = 70^\circ\text{C}$.

■ Recommended Operating Range

Parameter	Symbol	Range	Unit
Supply voltage	V_{CC}	10.8 to 13.2	V

■ Electrical Characteristics at $T_a = 25^\circ\text{C}$

Parameter	Symbol	Conditions	Min	Typ	Max	Unit
Tone control						
Volume max. level *	$V_{VO(max)}$	$V_{IN} = 1\text{ V[rms]}, f = 1\text{ kHz}$	-2.3	-0.3	1.7	dB
Volume typ. level *	$V_{VO(typ)}$	$V_{IN} = 1\text{ V[rms]}, f = 1\text{ kHz}$	-16.2	-13.2	-10.2	dB
Volume min. level *	$V_{VO(min)}$	$V_{IN} = 1\text{ V[rms]}, f = 1\text{ kHz}$	—	—	-75	dB
Bass: boost level	V_{BB}	$V_{IN} = 400\text{ mV[rms]}, f = 50\text{ Hz}$	9.2	11.2	13.2	dB
Bass: cut level	V_{BC}	$V_{IN} = 400\text{ mV[rms]}, f = 50\text{ Hz}$	-11.7	-9.7	-7.7	dB
Treble: boost level	V_{TB}	$V_{IN} = 400\text{ mV[rms]}, f = 20\text{ kHz}$	9.7	11.7	13.7	dB
Treble: cut level	V_{TC}	$V_{IN} = 400\text{ mV[rms]}, f = 20\text{ kHz}$	-12.1	-10.1	-8.1	dB
AGC						
Input/output level 1 *	V_{AGC1}	$V_{IN} = 1\text{ mV[rms]}, f = 1\text{ kHz}$	0.7	1.7	2.7	mV[rms]
Input/output level 2 *	V_{AGC2}	$V_{IN} = 50\text{ mV[rms]}, f = 1\text{ kHz}$	70	110	150	mV[rms]
Input/output level 3 *	V_{AGC3}	$V_{IN} = 1\text{ V[rms]}, f = 1\text{ kHz}$	275	345	415	mV[rms]
Circuit current *	I_{CC}	$V_{IN} = 0\text{ mV}$	25	45	65	mA
Total harmonics distortion *	THD	$V_{IN} = 1\text{ V[rms]}, f = 1\text{ kHz}$	—	0.1	0.5	%
Max. input voltage *	$V_{IN(max)}$	THD = 1%	2.8	—	—	V[rms]
Mute level *	V_{MUTE}	$V_{IN} = 1\text{ V[rms]}, f = 1\text{ kHz}$	—	—	-80	dB
Noise level at volume max. *	$V_{NO(max)}$	$V_{IN} = 0\text{ mV}, R_g = 0\ \Omega$	—	115	200	$\mu\text{V[rms]}$
Noise level at volume min. *	$V_{NO(min)}$	$V_{IN} = 0\text{ mV}, R_g = 0\ \Omega$	—	45	100	$\mu\text{V[rms]}$
Surround level (max.) *	$V_{SU(max)}$	$V_{IN} = 100\text{ mV[rms]}, f = 1\text{ kHz}$	12.4	14.4	16.4	dB
Surround level (min.) *	$V_{SU(min)}$	$V_{IN} = 100\text{ mV[rms]}, f = 1\text{ kHz}$	2.9	4.9	6.9	dB
Surround level at loop on *	V_{LPSUL}	$V_{IN} = 100\text{ mV[rms]}, f = 1\text{ kHz}$	4.9	6.9	8.9	dB
Level at bass add on *	V_{BAONL}	$V_{IN} = 400\text{ mV[rms]}, f = 50\text{ Hz}$	3.95	5.95	7.95	dB
Cross talk *	CT	$V_{IN} = 1\text{ V[rms]}, f = 1\text{ kHz}$	—	-70	-68.5	dB
Channel balance *	CB	$V_{IN} = 1\text{ V[rms]}, f = 1\text{ kHz}$	-1.5	0	1.5	dB
L-R volume tracking (1/4) *	V_{TR}	$V_{IN} = 1\text{ V[rms]}, f = 1\text{ kHz}$	-2.0	0	2.0	dB
I²C interface						
Sink current at ACK	I_{ACK}	Maximum value of pin 15 sink current at ACK	2.0	10	—	mA
SCL, SDA signal high-level input	V_{IHI}		3.5	—	5.0	V
SCL, SDA signal low-level input	V_{ILO}		0	—	0.9	V
Max. allowable input frequency	f_{Imax}		—	—	100	kbit/s

Note) * : Uses DIN audio filter.

■ Electrical Characteristics at $T_a = 25^\circ\text{C}$ (continued)

• Design reference data

Note) The characteristics listed below are theoretical values based on the IC design and are not guaranteed.

Parameter	Symbol	Conditions	Min	Typ	Max	Unit
I²C interface						
Bus free before start	t_{BUS}		4.0	—	—	μs
Start condition setup time	$t_{\text{SU, STA}}$		4.0	—	—	μs
Start condition hold time	$t_{\text{HD, STA}}$		4.0	—	—	μs
Low period SCL, SDA	t_{LO}		4.0	—	—	μs
High period SCL	t_{HI}		4.0	—	—	μs
Rise time SCL, SDA	t_r		—	—	1.0	μs
Fall time SCL, SDA	t_f		—	—	0.35	μs
Data setup time (write)	$t_{\text{SU, DAT}}$		0.25	—	—	μs
Data hold time (write)	$t_{\text{HD, DAT}}$		0	—	—	μs
Acknowledge setup time	$t_{\text{SU, ACK}}$		—	—	3.5	μs
Acknowledge hold time	$t_{\text{HD, ACK}}$		0	—	—	μs
Stop condition setup time	$t_{\text{SU, STO}}$		4.0	—	—	μs
DAC						
6-bit DAC DNLE	L ₆	1 LSB = (data (max.) – data (00))/63	0.1	1.0	1.9	LSB/step

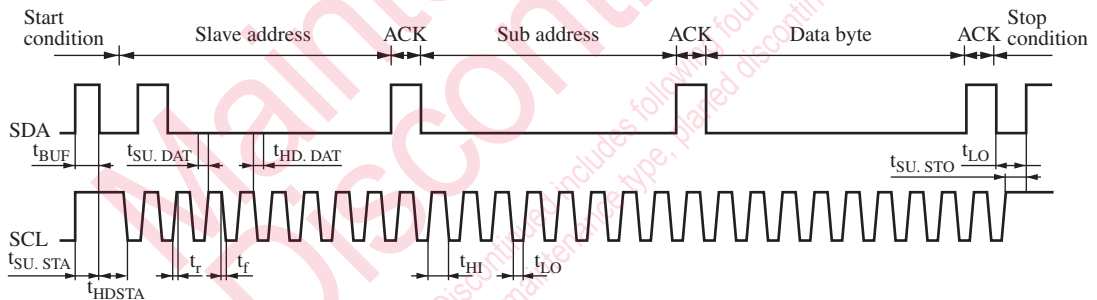

■ Terminal Equivalent Circuits

Pin No.	Equivalent circuit	Description	Voltage (V)
1		R-In: R-ch. Input pin	6
2	—	GND: GND pin	0

■ Terminal Equivalent Circuits (continued)

Pin No.	Equivalent circuit	Description	Voltage (V)
3		<p>AGC Adj.:</p> <p>AGC on/off changeover</p> <p>AGC off at 1.2 V or less.</p>	—
4		<p>LS1:</p> <p>AGC level sensor 1</p>	7
5		<p>LS2:</p> <p>AGC level sensor 1, 2</p>	0.5 to 1.5
6		<p>V_{REF} :</p> <p>Reference voltage to be stabilized</p>	6
7		<p>PS:</p> <p>Phase shift pin</p>	6
8		<p>STB:</p> <p>L/R/C-ch. bass DAC output pin</p>	3±1

■ Terminal Equivalent Circuits (continued)

Pin No.	Equivalent circuit	Description	Voltage (V)
9		RB: R-ch. bass f_C setting pin	6
10		RT: R-ch. treble f_C setting pin	6
11		R-Out: R-ch. output pin	6
12		SRV: R-ch. volume DAC output pin	3 ± 1
13		SLV: L-ch. volume DAC output pin	3 ± 1
14		SCL: I ² C bus clock input pin	V_{CC}

■ Terminal Equivalent Circuits (continued)

Pin No.	Equivalent circuit	Description	Voltage (V)
15		SDA: I ² C bus data input pin	V _{CC}
16		SCV: C-ch. volume DAC output pin	3±1
17		DAC1: Extension DAC output pin	0 or 5
18		C-Out: C-ch. output pin	6
19		L-Out: L-ch. output pin	6
20		CT: C-ch. treble f _C setting pin	6

■ Terminal Equivalent Circuits (continued)

Pin No.	Equivalent circuit	Description	Voltage (V)
21		CB: C-ch. bass f_c setting pin	6
22		LT: L-ch. treble f_c setting pin	6
23		LB: L-ch. bass f_c setting pin	6
24		B-Gain: Bass mix. gain adjustment pin	6
25		STT: L/R/C-ch. treble DAC output pin	3 ± 1
26		B-In: Bass detection LPF ope.-amp. input pin	6

■ Terminal Equivalent Circuits (continued)

Pin No.	Equivalent circuit	Description	Voltage (V)
27		ADD: L+R (after AGC) output pin	6
28		C-In: C-ch. input pin	6
29	—	V _{CC} : Power supply pin	12
30		L-In: L-ch. input pin	6

■ Technical Information

• I²C bus

1. DAC

- 1) Built-in 5 DAC controls and 8 switches
- 2) Incorporating auto-increment functions
 - (1) Sub address 0* : Auto-increment mode
(Data are inputted by the change of sub-address according to the transfer when data are sequentially transferred.)
 - (2) Sub address 8* : Data renewal mode
(Data are inputted with the same sub-address when data are sequentially transferred.)

3) I²C bus protocol

- (1) Slave address: 10000000 (80H)
- (2) Format (normal)

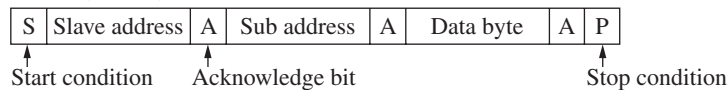

(3) Auto-increment mode/data renewal mode

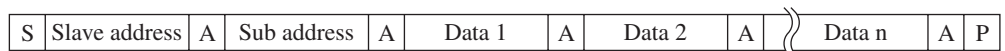

- 4) Typical data should be inputted at power on because initial state of DAC is not guaranteed.

■ Technical Information (continued)

• I²C bus (continued)

2. I²C bus transfer sequence

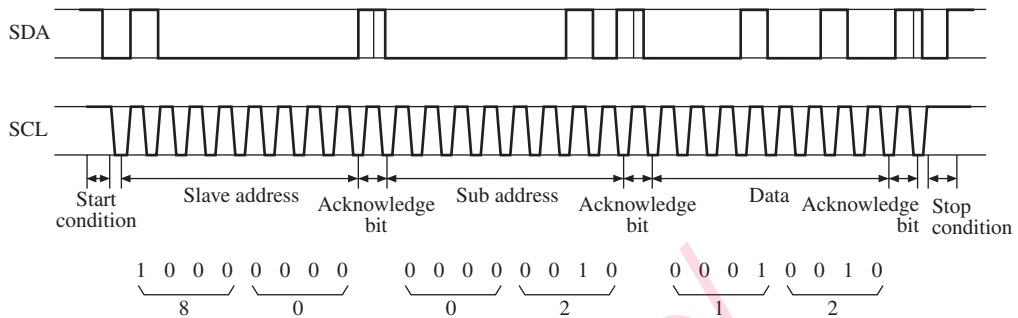

Transfer message example

Two type of transfer messages of SCL and SDA are sent by synchronous serial transfer. SCL is a clock of constant frequency and SDA indicates address data to control receiving side and is sent in parallel by synchronizing with SCL. Data are transferred in principle with 8-bit 3 octet (byte) and acknowledge bit exists every one octet. Frame organization are described as follows:

- 1) Start condition When SDA becomes low from high at SCA = high, receiver is on a data receiving mode.
- 2) Stop condition When SDA becomes high from low at SCA = high, receiver stops receiving data.
- 3) Slave address Address determined by device. Receiving is stopped when address of another device is sent.
- 4) Sub address Address determined by function
- 5) Data Data to control
- 6) Acknowledge bit To let the master acknowledge that data has been received for each octet in such manner that the master sends a high signal and the receiver sends back a low signal as shown by above transfer sequence.

SDA is not changed when SCL is high except start and stop conditions.

3. Sub address byte and data byte format

Sub address	Upper MSB				Data byte			
	D7	D6	D5	D4	D3	D2	D1	D0
00	← L-ch. vol. →				← Mute on/off →			AGC on/off
01	← R-ch. vol. →				← C-ch. mute on/off →			Surround on/off
02	← C-ch. vol. →				← Bass mix. on/off →			C-In select
03	← L/R/C treble →				← L/R/C bass →			
04	0	0	0	0	0	0	0	0
05	← Surround effect →				Surround loop on/off	0	0	DAC1 L/H

■ Technical Information (continued)

• I²C bus (continued)

3. Sub address byte and data byte format (continued)

- | | |
|---------------------------------------------------------------------------------|------------------------------------------------------------|
| 1) L-ch. Vol., R-ch. Vol., C-ch. Vol.
Min. at data = 00
Max. at data = 3F | 5) DAC1
Low (0 V) at data = 0
High (5 V) at data = 1 |
| 2) L/R/C treble, L/R/C bass
Min. at data = 0
Max. at data = F | 6) C-In select
L+R in at data = 0
C-In at data = 1 |
| 3) Surround effect
Min. at data = 0
Max. at data = F | 7) C-ch. mute
Off at data = 0
On at data = 1 |
| 4) Switches (except C-ch. mute SW)
Off at data = 0
On at data = 1 | |

■ Application Circuit Example

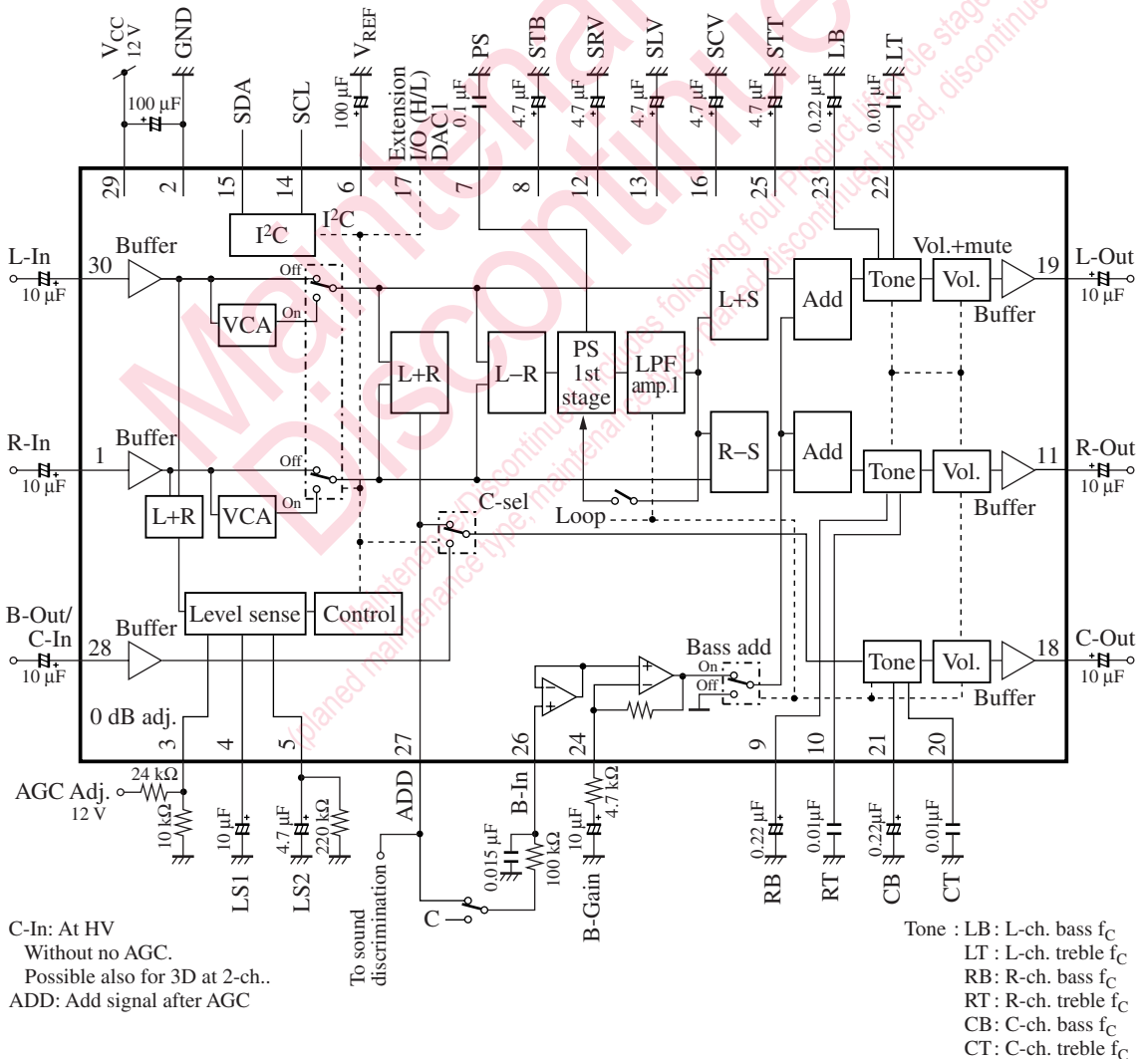

■ New Package Dimensions (Unit: mm)

- SDIP030-P-0400B (Lead-free package)

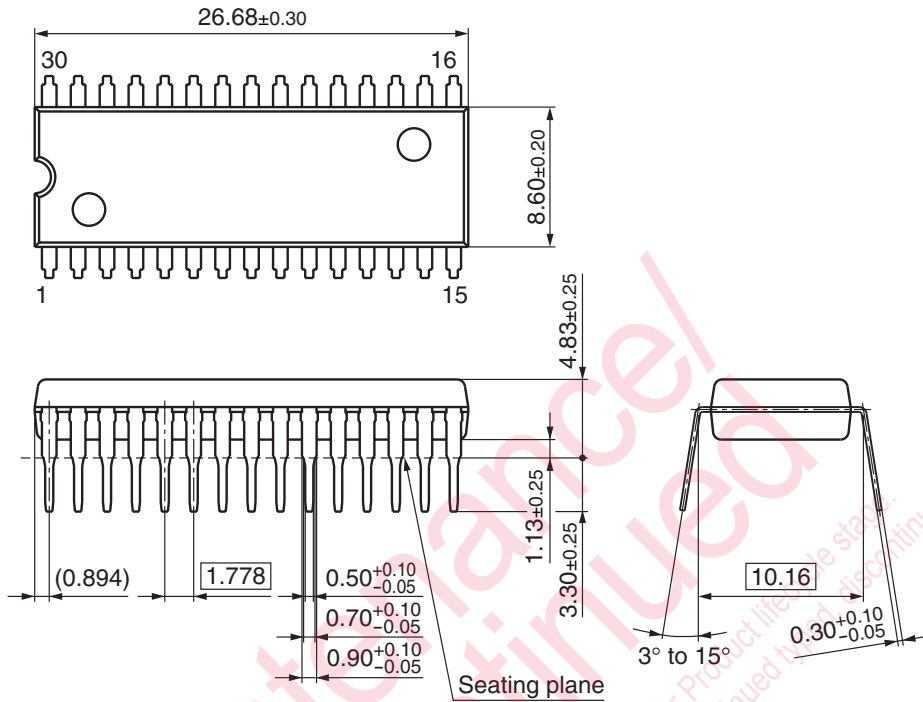

Request for your special attention and precautions in using the technical information and semiconductors described in this book

- (1) If any of the products or technical information described in this book is to be exported or provided to non-residents, the laws and regulations of the exporting country, especially, those with regard to security export control, must be observed.
- (2) The technical information described in this book is intended only to show the main characteristics and application circuit examples of the products, and no license is granted under any intellectual property right or other right owned by our company or any other company. Therefore, no responsibility is assumed by our company as to the infringement upon any such right owned by any other company which may arise as a result of the use of technical information described in this book.
- (3) The products described in this book are intended to be used for standard applications or general electronic equipment (such as office equipment, communications equipment, measuring instruments and household appliances).
Consult our sales staff in advance for information on the following applications:
 - Special applications (such as for airplanes, aerospace, automobiles, traffic control equipment, combustion equipment, life support systems and safety devices) in which exceptional quality and reliability are required, or if the failure or malfunction of the products may directly jeopardize life or harm the human body.
 - Any applications other than the standard applications intended.
- (4) The products and product specifications described in this book are subject to change without notice for modification and/or improvement. At the final stage of your design, purchasing, or use of the products, therefore, ask for the most up-to-date Product Standards in advance to make sure that the latest specifications satisfy your requirements.
- (5) When designing your equipment, comply with the range of absolute maximum rating and the guaranteed operating conditions (operating power supply voltage and operating environment etc.). Especially, please be careful not to exceed the range of absolute maximum rating on the transient state, such as power-on, power-off and mode-switching. Otherwise, we will not be liable for any defect which may arise later in your equipment.
 - Even when the products are used within the guaranteed values, take into the consideration of incidence of break down and failure mode, possible to occur to semiconductor products. Measures on the systems such as redundant design, arresting the spread of fire or preventing glitch are recommended in order to prevent physical injury, fire, social damages, for example, by using the products.
- (6) Comply with the instructions for use in order to prevent breakdown and characteristics change due to external factors (ESD, EOS, thermal stress and mechanical stress) at the time of handling, mounting or at customer's process. When using products for which damp-proof packing is required, satisfy the conditions, such as shelf life and the elapsed time since first opening the packages.
- (7) This book may be not reprinted or reproduced whether wholly or partially, without the prior written permission of Matsushita Electric Industrial Co., Ltd.