

AN8730SB

4-channel driver IC for optical disk

■ Overview

The AN8730SB is a 4-channel driver IC, which can operate in a low voltage, employing the low power consumption type H-bridge system with a switching regulator. It is especially suited for a portable CD/MD player.

■ Features

- Low power consumption due to PWM control of power supply
- Wide output D-range independent of the reference voltage of the system
- Enable to set input/output gain by an external resistor
- Independent power on/off for 2 channels and simultaneous on/off for other 2 channels as well
- Battery voltage detection circuit built-in
- Thermal shut-down circuit (with hysteresis) built-in

■ Applications

- Portable CD/MD

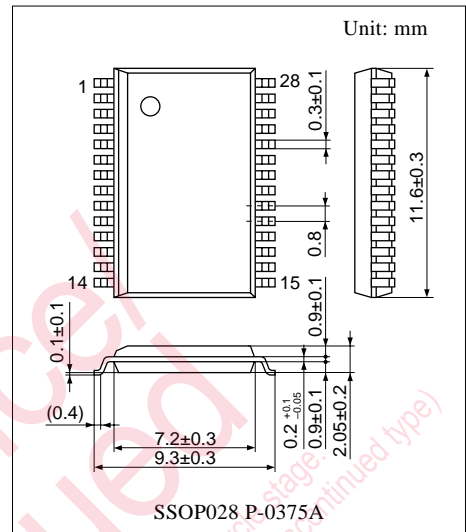

■ Block Diagram

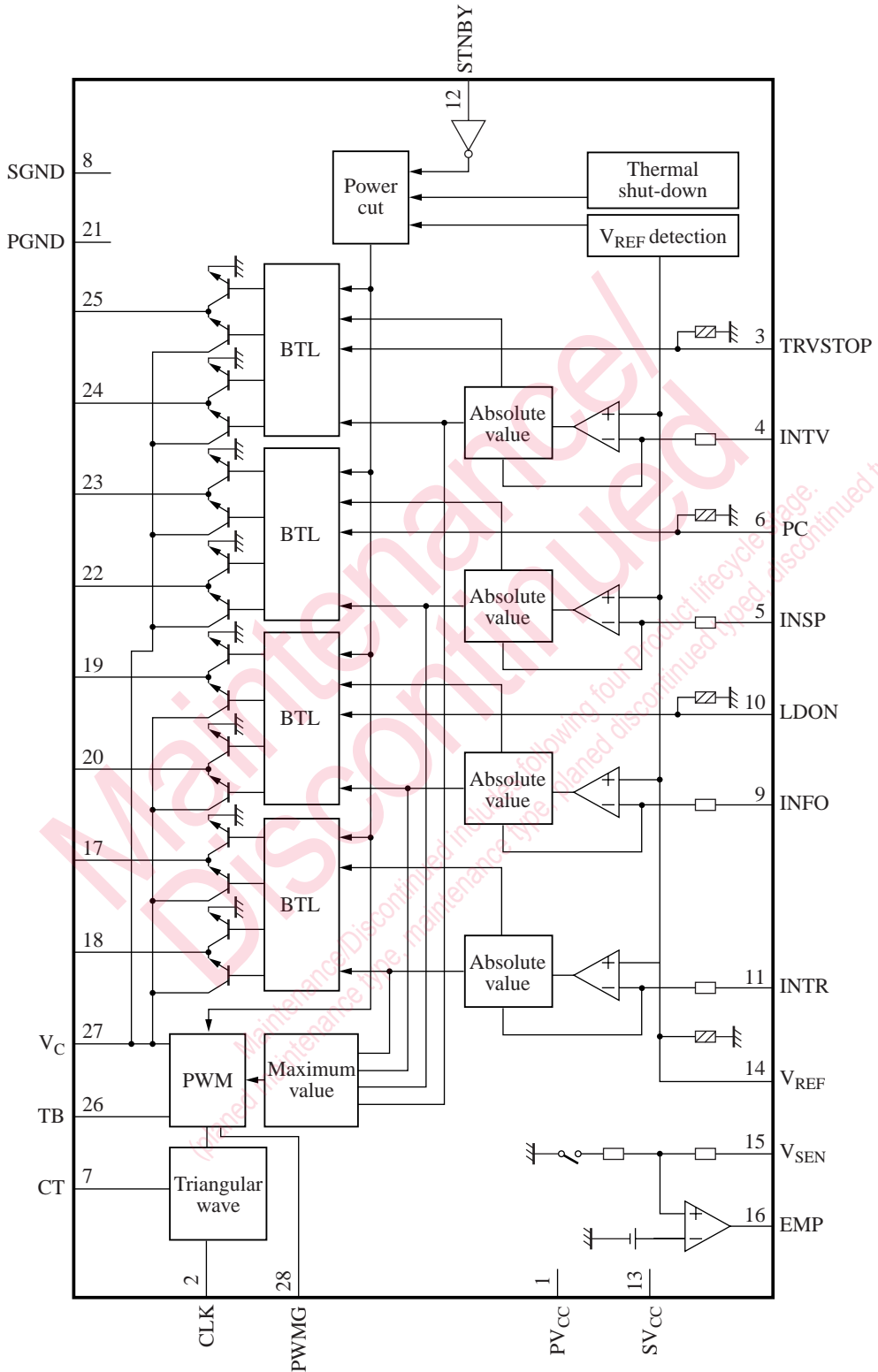

Pin Descriptions

Pin No.	Symbol	Description	Pin No.	Symbol	Description
1	PV _{CC}	Supply voltage pin	15	V _{SEN}	Empty detection input pin
2	CLK	External sync. input pin	16	EMP	Empty detection output pin
3	TRVSTOP	Driver on-off control pin	17	TR-	Driver output pin
4	INTV	Driver input pin	18	TR+	Driver output pin
5	INSP	Driver input pin	19	FO-	Driver output pin
6	PC	Driver on-off control pin	20	FO+	Driver output pin
7	CT	Triangular wave oscillation pin	21	PGND	Ground pin
8	SGND	Ground pin	22	SP+	Driver output pin
9	INFO	Driver input pin	23	SP-	Driver output pin
10	LDON	Driver on-off control pin	24	TV+	Driver output pin
11	INTR	Driver input pin	25	TV-	Driver output pin
12	STNBY	Standby mode input pin	26	TB	PWM circuit output pin
13	SV _{CC}	Supply voltage pin	27	V _C	Drive supply voltage pin
14	V _{REF}	V _{REF} input pin	28	PWMG	PWM loop gain adjustment pin

Absolute Maximum Ratings

Parameter	Symbol	Rating	Unit
Supply voltage	PV _{CC}	15	V
	SV _{CC}	6	
	V _C	9	
Supply voltage range	PV _{CC}	-0.3 to +15.0	V
	SV _{CC}	-0.3 to +6.0	
Supply current	I _{CC}	—	mA
Supply current 1	I _{SVCC}	50	mA
Supply current 2	I _{PVCC}	100	mA
Drive output current	I _O	500	mA
Power dissipation *2	P _D	345	mW
Max. application voltage to V _{SEN} pin	V _{10max}	15.0	V
Operating ambient temperature *1	T _{opr}	-25 to +75	°C
Storage temperature *1	T _{stg}	-55 to +125	°C

Note) 1. Do not apply external currents or voltages to any pins not specifically mentioned.

For circuit currents, '+' denotes current flowing into the IC, and '-' denotes current flowing out of the IC.

2. *1: Except for the operating ambient temperature and storage temperature, all ratings are for T_a = 25°C.

*2: T_a = 75°C. For the independent IC without a heat sink. Refer to "Application Note" at mounting on PCB.

Recommended Operating Range

Parameter	Symbol	Range	Unit
Supply voltage	PV _{CC}	2.7 to 14.0	V
	SV _{CC}	2.7 to 5.5	

■ Recommended Operating Range

Parameter	Symbol	Range	Unit
Supply voltage	PV _{CC}	2.7 to 14.0	V
	SV _{CC}	2.7 to 5.5	

■ Electrical Characteristics at SV_{CC} = PV_{CC} = 5 V, T_a = 25°C

Parameter	Symbol	Conditions	Min	Typ	Max	Unit
<Common block>						
Supply current of SV _{CC} at no load	I _{13Q}	PV _{CC} = SV _{CC} = 5 V, V _{REF} = 1.5 V	—	4.2	7.0	mA
In standby mode supply current of SV _{CC} at no load	I _{13S}	PV _{CC} = SV _{CC} = 5 V, V _{REF} = 1.5 V STNBY = 0 V	—	0.8	2	mA
Supply current of PV _{CC} at no load	I _{1Q}	PV _{CC} = SV _{CC} = 5 V, V _{REF} = 1.5 V	—	3.4	5.5	mA
V _C leak current	I _{VCL}	V _C = 9 V	—	—	10	μA
Free-run oscillation frequency at CT pin	f _{3F}	C _T = 150 pF, 470 kΩ	—	—	165	kHz
CKL pin block						
CLK pin input threshold V _{THH}	V _{2THH}	f _{IN} = 88.2 kHz	2.0	—	—	V
CLK pin input threshold V _{THL}	V _{2THL}	f _{IN} = 88.2 kHz	—	—	0.8	V
Empty detection block						
EMP pin detection voltage	V _{16TH1}		1.7	1.85	1.9	V
Hysteresis width from EMP pin empty detection to recovery	V _{16H}		50	80	110	mV
EMP pin output voltage	V _{16O}	I _{EMP} = +1.0 mA, V _{SEN} = 1 V	—	—	0.5	V
V _{SEN} pin input resistance	R ₁₅		21.5	25	28.5	kΩ
<Driver block>						
Focus						
Transfer gain '+'	GF+	V _{REF} = 1.5 V	11.3	13.8	16.3	dB
'+' / '-' transfer gain relative ratio	G+/G-	V _{REF} = 1.5 V	-1.5	0	+1.5	dB
Dead zone converted to INFO pin input	IDZF0	V _{REF} = 1.5 V	-10	0	+10	mV
INFO pin input internal resistance	R ₉	V _{REF} = 1.5 V, LDON = 3.0 V	0.8	1.0	1.2	kΩ
Output offset voltage	V _{FOOFF} (OFF)	V _{REF} = INFO = 1.6 V	-50	—	+50	mV
Max. output amplitude '+'	V _{FOLM+}	PV _{CC} = SV _{CC} = 5 V, V _{REF} = 1.5 V	2.5	3.4	—	V
Max. output amplitude '-'	V _{FOLM-}	PV _{CC} = SV _{CC} = 5 V, V _{REF} = 1.5 V	2.5	3.4	—	V
LDON pin high-level threshold	V _{10THH}	V _{REF} = 1.6 V, INFO = 1.8 V	2.0	—	—	V
LDON pin low-level threshold	V _{10THL}	V _{REF} = 1.6 V, INFO = 1.8 V	—	—	1.0	V
V _{REF} pin driver on-off high-level threshold	V _{14THH}	INFO = 1.8 V	1.25	—	—	V
V _{REF} pin driver on-off low-level threshold	V _{14THL}	INFO = 1.8 V	—	—	0.75	V

■ Electrical Characteristics at $V_{CC} = PV_{CC} = 5\text{ V}$, $T_a = 25^\circ\text{C}$ (continued)

Parameter	Symbol	Conditions	Min	Typ	Max	Unit
<Driver block> (continued)						
Tracking						
Transfer gain '+'	GTR+		11.3	13.8	16.3	dB
'+' / '-' transfer gain relative ratio	G+/G-		-1.5	0	+1.5	dB
Dead zone converted to INTR pin input	IDZTR		-10	0	+10	mV
INTR pin input internal resistance	R ₁₁		0.8	1.0	1.2	k Ω
Output offset voltage	V _{TROFF} (OUT)		-50	0	+50	mV
Max. output amplitude '+'	V _{TRLM+}		2.5	3.4	—	V
Max. output amplitude '-'	V _{TRLM-}		2.5	3.4	—	V
Spindle						
Transfer gain '+'	GSP+		17.5	20.0	22.5	dB
'+' / '-' transfer gain relative ratio	G+/G-		-1.7	-0.2	+1.3	dB
Dead zone converted to INSP pin input	IDZSP		-10	0	+10	mV
INSP pin input internal resistance	R ₅		0.8	1.0	1.2	k Ω
Output offset voltage	V _{SPOFF} (OUT)		-100	0	+100	mV
Max. output amplitude '+'	V _{SPLM+}		2.5	3.4	—	V
Max. output amplitude '-'	V _{SPLM-}		2.5	3.4	—	V
PC pin threshold high-level	V _{6THH}		2.0	—	—	V
PC pin threshold low-level	V _{6THL}		—	—	1.0	V
Traverse						
Transfer gain '+'	GTV+		11.3	13.8	16.3	dB
'+' / '-' transfer gain relative ratio	G+/G-		-1.8	-0.3	+1.2	dB
Dead zone converted to INTV pin input	IDZTV		-10	0	+10	mV
INTV pin input internal resistance	R ₄		0.8	1.0	1.2	k Ω
Output offset voltage	V _{TVOFF} (OUT)		-50	0	+50	mV
Max. output amplitude '+'	V _{TVLM+}		2.5	3.4	—	V
Max. output amplitude '-'	V _{TVLM-}		2.5	3.4	—	V
TRVSTOP pin threshold high-level	V _{6THH}		2.0	—	—	V
TRVSTOP pin threshold low-level	V _{3THL}		—	—	1.0	V
PWM-comp.						
TB pin sink current ability	I _{TB}	V _{REF} = 1.6 V, INFO = 2.1 V	9	12	15	mA
VC level shift	V _C	V _{REF} = 1.6 V, INFO = 1.8 V	0.32	0.52	0.62	V

■ Electrical Characteristics at $SV_{CC} = PV_{CC} = 5\text{ V}$, $T_a = 25^\circ\text{C}$ (continued)

• Design reference data

Note) The characteristics listed below are theoretical values based on the IC design and are not guaranteed.

Parameter	Symbol	Conditions	Min	Typ	Max	Unit
Temperature protection circuit						
Thermal shut-down operating temperature driver operation → stop	TON		—	150	—	°C
Thermal shut-down operating temperature hysteresis width	DT		—	30	—	°C

■ Application Note

• $P_D - T_a$ curves of SSOP28-P-0375A

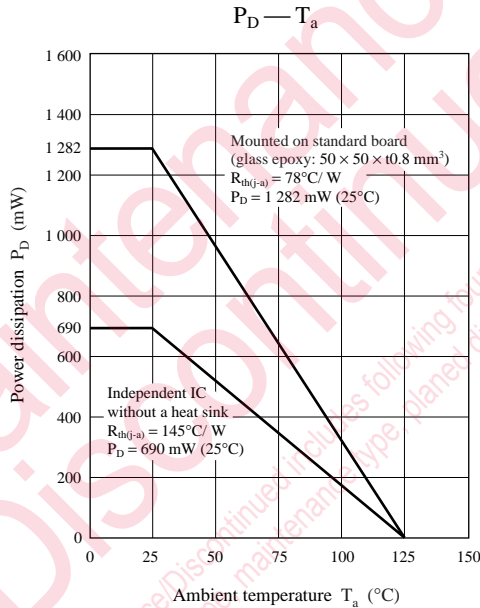

■ Application Circuit Example

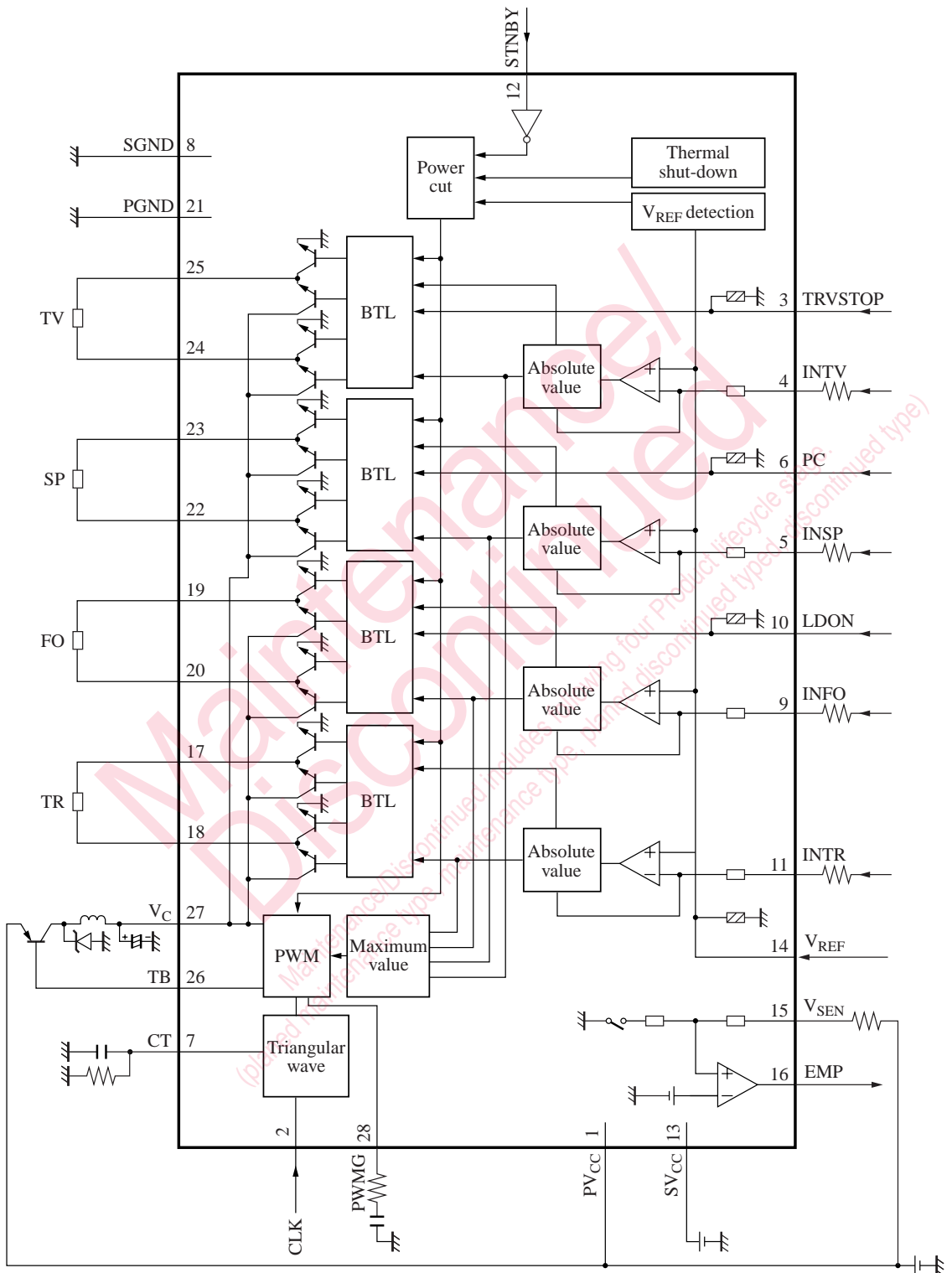

Request for your special attention and precautions in using the technical information and semiconductors described in this book

- (1) If any of the products or technical information described in this book is to be exported or provided to non-residents, the laws and regulations of the exporting country, especially, those with regard to security export control, must be observed.
- (2) The technical information described in this book is intended only to show the main characteristics and application circuit examples of the products, and no license is granted under any intellectual property right or other right owned by our company or any other company. Therefore, no responsibility is assumed by our company as to the infringement upon any such right owned by any other company which may arise as a result of the use of technical information described in this book.
- (3) The products described in this book are intended to be used for standard applications or general electronic equipment (such as office equipment, communications equipment, measuring instruments and household appliances).
Consult our sales staff in advance for information on the following applications:
 - Special applications (such as for airplanes, aerospace, automobiles, traffic control equipment, combustion equipment, life support systems and safety devices) in which exceptional quality and reliability are required, or if the failure or malfunction of the products may directly jeopardize life or harm the human body.
 - Any applications other than the standard applications intended.
- (4) The products and product specifications described in this book are subject to change without notice for modification and/or improvement. At the final stage of your design, purchasing, or use of the products, therefore, ask for the most up-to-date Product Standards in advance to make sure that the latest specifications satisfy your requirements.
- (5) When designing your equipment, comply with the range of absolute maximum rating and the guaranteed operating conditions (operating power supply voltage and operating environment etc.). Especially, please be careful not to exceed the range of absolute maximum rating on the transient state, such as power-on, power-off and mode-switching. Otherwise, we will not be liable for any defect which may arise later in your equipment.
 - Even when the products are used within the guaranteed values, take into the consideration of incidence of break down and failure mode, possible to occur to semiconductor products. Measures on the systems such as redundant design, arresting the spread of fire or preventing glitch are recommended in order to prevent physical injury, fire, social damages, for example, by using the products.
- (6) Comply with the instructions for use in order to prevent breakdown and characteristics change due to external factors (ESD, EOS, thermal stress and mechanical stress) at the time of handling, mounting or at customer's process. When using products for which damp-proof packing is required, satisfy the conditions, such as shelf life and the elapsed time since first opening the packages.
- (7) This book may be not reprinted or reproduced whether wholly or partially, without the prior written permission of Matsushita Electric Industrial Co., Ltd.