



HV30

High Voltage 7-Segment Latch/Decoder/  
EL-Display Driver

Preliminary  
T-51-17

Ordering Information

Device	Package Options			
	20-Pin Ceramic	20-Pin CERDIP	20-Pin Plastic	Die
HV30	HV30C	HV30D	HV30P	HV30X

Features

- High voltage outputs 180V
- High current capability 50mA peak
- Wide temperature range -40°C to +85°C
- Latch storage of code and decimal point
- Blanking
- Lamp test capability
- Leading zero blanking

Absolute Maximum Ratings\*

Supply voltage	4.75V to 12V
Input Voltage $V_{IN}$	-0.5V to $V_{CC}$
Output Voltage $V_O$	0V TO 180V
Output current $I_O$ (continuous)	5mA
Output current $I_O$ (peak)	60mA
Operating temperature range	-40°C to +85°C
Storage temperature range	-65°C to 150°C

\*Over operating free-air temperature range unless otherwise noted.

General Description

The HV30 is a 7-segment Decoder with decimal point and high voltage open drain outputs. It is specifically designed to drive electroluminescent displays manufactured by the Lohja Corporation but can also be used to drive other displays.

The BCD and decimal point inputs are latched on the trailing edge of the latch enable LE input.

All high voltage outputs can be put in the high impedance state by either the blanking input (BI) or the ripple blanking input (RBI) when the BCD data is all "0".

All outputs can be put in the low impedance state by bringing the lamp test low. There is an internal pull-down resistor on the lamp test input. All other inputs are protected with a zener diode to ground and a series resistor.

Pin Configuration

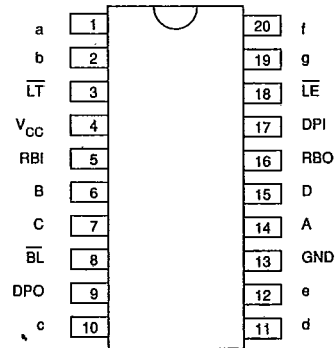

top view  
20-pin DIP

**Electrical Characteristics** (Over operating free-air temperature range, unless otherwise noted)

T-51-17

**DC Characteristic**

Symbol	Parameter	Min	Typ	Max	Units	Conditions
V <sub>CC</sub>	Supply voltage	4.75	10	12	V	
I <sub>CC</sub>	Supply current		5	10	mA	V <sub>CC</sub> = 10V, all inputs low except LT = "1"
V <sub>IL</sub>	Input low voltage	-0.5		0.8	V	V <sub>CC</sub> = 10V
V <sub>IH</sub>	Input high voltage	6.5		V <sub>CC</sub>	V	V <sub>CC</sub> = 10V
V <sub>OL</sub>	Output low voltage, RBO			0.45	V	V <sub>CC</sub> = 10V, I <sub>OH</sub> = 0.9mA
V <sub>OH</sub>	Output high voltage, RBO	2.4			V	V <sub>CC</sub> = 10V, I <sub>OH</sub> = 0.9mA
The following specifications are for segment outputs (@ V <sub>CC</sub> = 10V):						
I <sub>O</sub> (continuous)	Output current			5	mA	
I <sub>O</sub> (peak)	Output current			50	mA	Note 1
I <sub>O</sub> (leakage)	Output current			2	μA	Note 2
I <sub>D</sub> (continuous)	Body diode current			-5	mA	
I <sub>D</sub> (peak)	Body diode current			-60	mA	Note 1
V <sub>OBR</sub>	Breakdown voltage	180			V	Note 3
V <sub>FD</sub>	Forward voltage drop across body diode			2.0	V	Note 4
R <sub>DS(ON)</sub>	Drain to source resistance			1000	Ω	Note 5

- Notes:
1. Peak Current is repetitive; f<sub>max</sub> = 1.5KHz, max duty cycle = 8.0%.
  2. BL - input at high level V<sub>O</sub> = +180V, T<sub>A</sub> = +85°C.
  3. I<sub>O</sub> leakage max 2.0μA.
  4. Diode Forward current 30mA.
  5. I<sub>O</sub> = 10mA.

**AC Characteristics** (V<sub>CC</sub> = +10V, T<sub>A</sub> = 25°C)

Symbol	Parameter	Min	Max	Units	Conditions
t <sub>ON</sub> (BCD)	Turn-on time of segment outputs from BCD-inputs		10	μs	Note 1
t <sub>ON</sub> (DPI)	Turn-on time of decimal point output from decimal point input		10	μs	Note 1
t <sub>ON</sub> (BL)	Turn-on time of segment outputs from blank input		10	μs	Note 1
t <sub>OFF</sub> (BCD)	Turn-off time of segment outputs from BCD-inputs		10	μs	Note 1
t <sub>OFF</sub> (DPI)	Turn-off time of decimal point output from decimal point input		10	μs	Note 1
t <sub>OFF</sub> (BL)	Turn-off time of segment outputs from blank input		10	μs	Note 1
t <sub>SU</sub>	Data set-up time		2	μs	
t <sub>H</sub>	Data hold time		2	μs	
t <sub>LE</sub>	Minimum valid latch enable pulse width		2	μs	
t <sub>PLH</sub>	Propagation delay from RBI to RBO		2	μs	Note 2
t <sub>PHL</sub>	Propagation delay from RBI to RBO		2	μs	Note 2
t <sub>ON</sub> (RBI)	Turn-on time of segment outputs from RBI-input		10	μs	Note 3
t <sub>OFF</sub> (RBI)	Turn-off time of segment outputs from RBI-input		10	μs	Note 3

- Notes:
1. LE input is at high level.
  2. LE input is at high level and input BCD code is 0.
  3. LE input is at high level, input BCD code is 0 and BL input is at low level.

### Switching Waveform

### Test Circuit

7-51-17

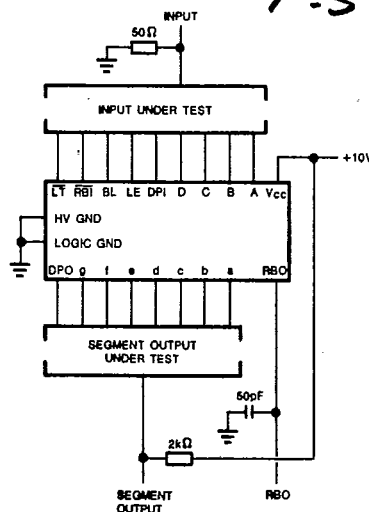
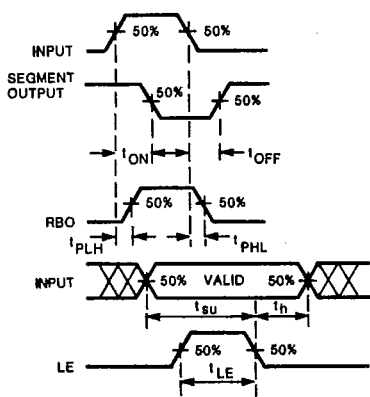

### Segment Identification

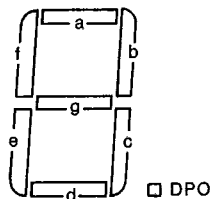

H = High level  
L = Low level  
X = Irrelevant

- Notes:
1. The segment outputs are ON or OFF according to data present on the input lines during the high to low transition of latch enable signal.
  2. If the latched BCD data is 0, RBO is at high level and the segment outputs except DPO are blanked. The state of DPO is determined by the latched DPI data. If the latched BCD data is greater than 0, RBO is at low level and the segment outputs are on or off according to the latched data.
  3. If the latched BCD data is 0, RBO is at high level. If the latched BCD data is 0, RBO is at high level. If the latched BCD data is greater than 0, RBO is at low level.

Logic Diagram

T-51-17

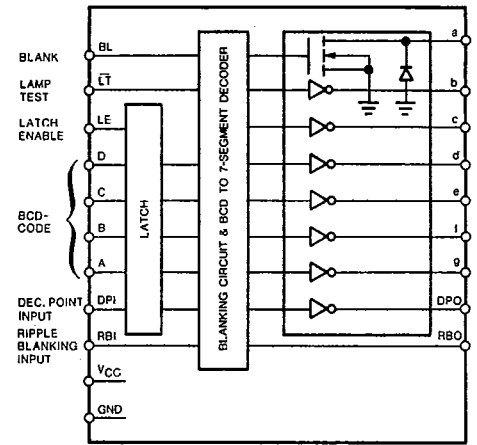

Truth Table

INPUTS										OUTPUTS								DISPLAY	
LT	RBI	DP-INPUT	BCD-INPUTS				LE	BL	RBO	SEGMENT OUTPUTS									
			D	C	B	A				a	b	c	d	e	f	g	DPO		
H	L	X	L	L	L	L	H	L	L	ON	ON	ON	ON	ON	ON	OFF	X	0	
H	H	X	L	L	L	L	H	L	H	OFF	OFF	OFF	OFF	OFF	OFF	OFF	X		
H	X	X	L	L	L	H	H	L	L	OFF	ON	ON	OFF	OFF	OFF	OFF	X	1	
H	X	X	L	L	H	L	H	L	L	ON	ON	OFF	ON	ON	OFF	ON	X	2	
H	X	X	L	L	H	H	H	L	L	ON	ON	ON	ON	OFF	OFF	ON	X	3	
H	X	X	L	H	L	L	H	L	L	OFF	ON	ON	OFF	OFF	ON	ON	X	4	
H	X	X	L	H	L	H	H	L	L	ON	OFF	ON	ON	OFF	ON	ON	X	5	
H	X	X	L	H	H	L	H	L	L	ON	OFF	ON	ON	ON	ON	ON	X	6	
H	X	X	L	H	H	H	H	L	L	ON	ON	ON	OFF	OFF	OFF	OFF	X	7	
H	X	X	H	L	L	L	H	L	L	ON	ON	ON	ON	ON	ON	ON	X	8	
H	X	X	H	L	L	H	H	L	L	ON	ON	ON	ON	OFF	ON	ON	X	9	
H	X	X	H	L	H	L	H	L	L	OFF	OFF	OFF	OFF	OFF	OFF	OFF	X		
H	X	X	H	L	H	H	H	L	L	OFF	OFF	OFF	OFF	OFF	OFF	OFF	X		
H	X	X	H	H	L	L	H	L	L	OFF	OFF	OFF	OFF	OFF	OFF	OFF	X		
H	X	X	H	H	H	L	H	L	L	OFF	OFF	OFF	OFF	OFF	OFF	OFF	X		
H	X	X	H	H	H	H	H	L	L	OFF	OFF	OFF	OFF	OFF	OFF	OFF	X		
H	X	L	X	X	X	X	H	L	X	X	X	X	X	X	X	X	OFF		
H	X	H	X	X	X	X	H	L	X	X	X	X	X	X	X	X	ON		
H	L	X	X	X	X	X	L	L	L	Note 1									
H	H	X	X	X	X	X	L	L	Note 2	Note 2									
H	L	X	X	X	X	X	L	H	L	OFF	OFF	OFF	OFF	OFF	OFF	OFF	OFF		
H	H	X	X	X	X	X	L	H	Note 3	OFF	OFF	OFF	OFF	OFF	OFF	OFF	OFF		
H	L	X	X	X	X	X	H	H	L	OFF	OFF	OFF	OFF	OFF	OFF	OFF	OFF		
H	H	X	L	L	L	L	H	H	H	OFF	OFF	OFF	OFF	OFF	OFF	OFF	OFF		
H	H	X	Greater Than BCD 0					H	H	L	OFF	OFF	OFF	OFF	OFF	OFF	OFF	OFF	
L	X	X	X	X	X	X	X	X	X	ON	ON	ON	ON	ON	ON	ON	ON	8.	