

Technical Data

STA / STT Series

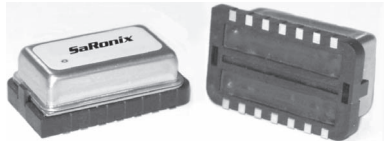

Description

A crystal controlled, low current, low jitter and high frequency oscillator with precise rise and fall times demanded in high performance networking, telecom and processor applications. The tri-state function enables the output to go high impedance. Available in a 14 or an 8 pin DIP compatible, resistance welded, all metal case. Pin 7 (or Pin 4) is grounded to case to reduce EMI. See photo above for new, full size metal package with a true SMD adapter. For this package option select option S in part number builder.

Applications & Features

- Fibre Channel
- Gigabit Ethernet
- High performance Processors
- True SMD DIL14 version available
- High Drive HCMOS, ACMOS or TTL capability
- Tri-State output
- Precise Rise/Fall Times
- Reduced EMI circuitry
- Short circuit protected output

Frequency Range:	STT 5V	STA 5V	STA 3.3V
Full Size:	250kHz - 135MHz	125kHz - 135MHz	125kHz - 125MHz
Half Size:	250kHz - 135MHz	500kHz - 135MHz	500kHz - 125MHz

Frequency Stability:	±20, ±25, ±50 or ±100 ppm over all conditions: calibration tolerance, operating temperature, rated input voltage change, load change, aging*, shock and vibration
* 1 year @ +40°C	

Temperature Range:	
Operating:	0 to +70°C or -40 to +85°C
Storage:	-55 to +125°C

Supply Voltage:	
Recommended Operating:	+5V ±10% or 3.3V ±10% (STA only)

Supply Current:	50mA typ, 70mA max @ 5V or 30mA typ, 45mA max @ 3.3V
-----------------	--

Output Drive:	
ACMOS / TTL	
Symmetry:	See Part Numbering Guide
Rise & Fall Times:	See Part Numbering Guide
Logic 0:	10% VDD or 0.5V max
Logic 1:	90% VDD or 2.5Vmin
Load:	50Ω ACMOS, 95Ω ACMOS @ 3.3V, 50mA sink & source @ TTL
Period Jitter RMS:	8ps max

Mechanical:	
Shock:	MIL-STD-883, Method 2002, Condition B
Solderability:	MIL-STD-883, Method 2003
Terminal Strength:	MIL-STD-202, Method 211, Conditions B2
Vibration:	MIL-STD-883, Method 2007, Condition A
Solvent Resistance:	MIL-STD-202, Method 215
Resistance to Soldering Heat:	MIL-STD-202, Method 210, Condition A, B or C

Environmental:	
Gross Leak Test:	MIL-STD-883, Method 1014, Condition C
Fine Leak Test:	MIL-STD-883, Method 1014, Condition A2
Thermal Shock:	MIL-STD-883, Method 1011, Conditions A
Moisture Resistance:	MIL-STD-883, Method 1004

Part Numbering Guide

Series	STA	A	9	9	B	3	-	90.0000	Frequency (MHz)
STA = ACMOS compatible, 3.3 or 5V									
STT = TTL compatible, 5V only									
Symmetry									
0 = 40/60% max, 0 to +70°C									
A = 45/55% max, 0 to +70°C									
STT to 80 MHz max only									
STA 3.3V to 109.9999 MHz max only									
2 = 40/60% max, -40 to +85°C									
STA 3.3V to 109.9999 MHz max only									
Standard* Rise/Fall Times									
1 = STT 4.0ns max 250kHz to 15 MHz full, to 35 MHz ½ size									
2 = STT 2.0ns max from 15+ MHz full, 35+ MHz ½ size to 60 MHz									
3 = STT 1.0ns max from 60+ MHz to 135 MHz									
7 = STA 5.5ns max, 125kHz to 15 MHz full, 500kHz to 35 MHz ½ size									
8 = STA 3.5ns max from 15+ MHz full, 35+ MHz ½ size to 60 MHz									
9 = STA 2ns max from 60+ MHz to 135 MHz(5V), to 125 MHz(3.3V)									
Supply									
blank = 5V (STA or STT, 135MHz max)									
3 = 3.3V (STA only, 125MHz max)									
Stability Tolerance									
AA = ±20ppm, 80MHz max, 0 to +70°C only									
A = ±25ppm, 80MHz max, 0 to +70°C only									
B = ±50ppm									
C = ±100ppm									
Package Size / Style									
0 = Full Size									
9 = ½ Size									
K = Full Size, Gull Wing									
J = ½ Size, Gull Wing									
N = ½ Size, Gull Wing, Spanked Leads									
S = Full Size, True SMD Adapter									

*R/F times are standard with given frequency ranges, non-standard R/F times available on some models, please contact SaRonix

Example PN: STT220C - 60.0000

DS-108 REV K

Technical Data

STA / STT Series

Package Details

FULL SIZE PACKAGE

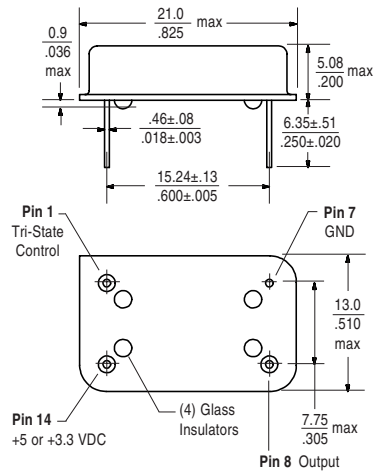

Marking Format **

Includes Date Code, Frequency & Part Number

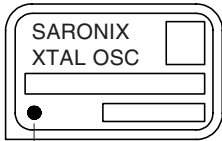

HALF SIZE PACKAGE

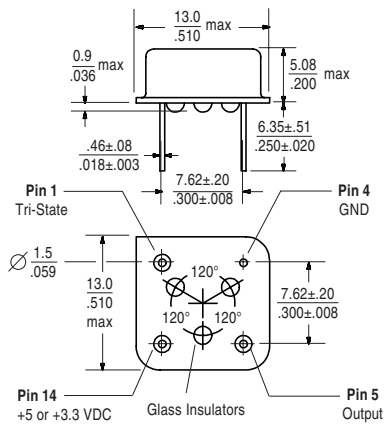

Marking Format **

Includes Date Code, Frequency & Part Number



** Exact location of items may vary

Scale: None (Dimensions in mm / inches)

Output Waveform

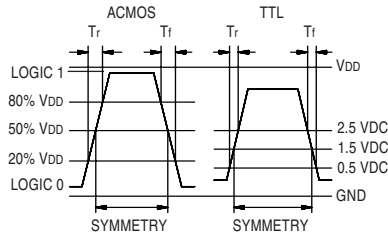

Tri-State Logic Table

Pin 1 Input	Output Standard Logic
Logic 1 or NC	Oscillation
Logic 0 or GND	High Impedance

Required Input Levels on Pin 1:
Logic 1 = 2.2V min
Logic 0 = 0.8V max

Test Circuit

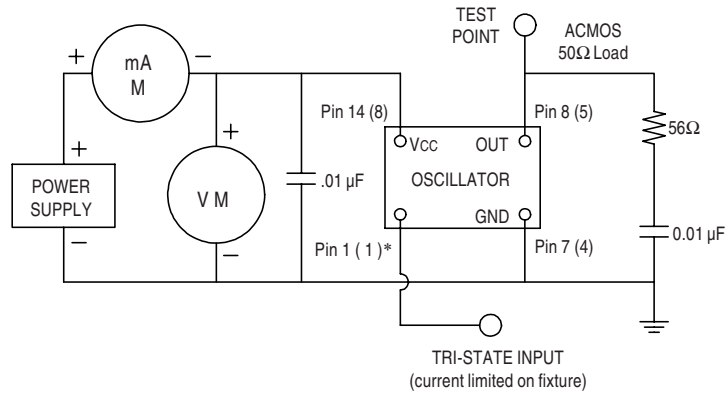

* () Indicates pin numbers for half-size package

95Ω ACмос TEST CIRCUIT (3.3V operation)

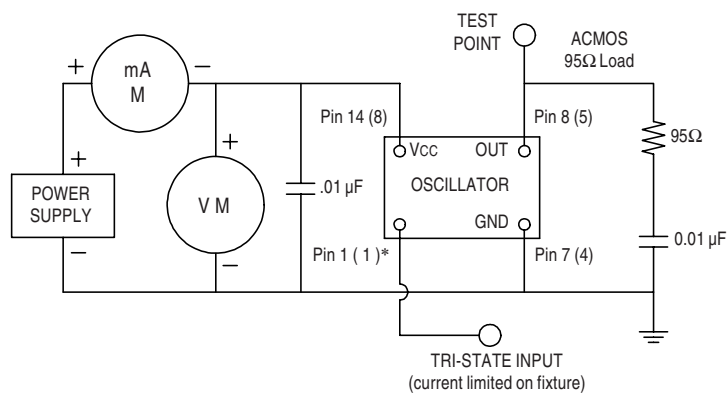

* () Indicates pin numbers for half-size package

95Ω ACмос TEST CIRCUIT (3.3V operation)

All specifications are subject to change without notice.