

**LC7465M****SANYO****Infrared Remote Control Transmitter IC****Preliminary****Overview**

The LC7465M is a 64-key infrared remote controller transmitter IC that incorporates key-scanning, oscillator and timing circuits on-chip, resulting in a very low external component count.

The LC7465M generates 256 function codes using the 64 function keys. The output data format comprises the mask-programmed custom code, the parity field, the mask-programmed system code, the product code, the function code and the data check code.

The LC7465M operates from a 2.0 to 3.6 V supply and is available in 30-pin MFPs.

**Features**

- Low external component count.
- 64 function keys.
- 256 function codes.
- Mask-programmable custom and system codes.
- 64 product codes.
- Output conforms to Japan's Association for Electric Home Appliances recommended standards for infrared remote controls.
- On-chip input pull-down resistors.
- 2.0 to 3.6 V supply.
- 30-pin MFP.

**Package Dimensions**

unit:mm

3073B-MFP30SD

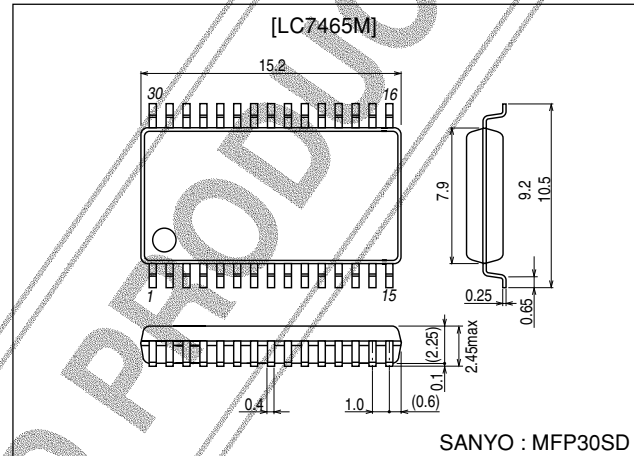
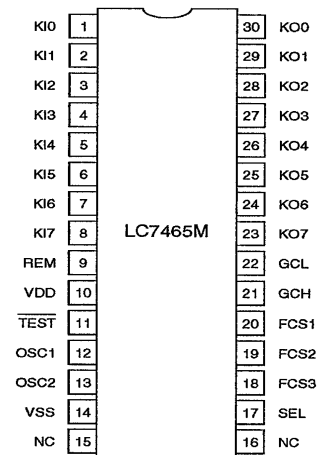
**Pin Assignment**

Top view

■ Any and all SANYO products described or contained herein do not have specifications that can handle applications that require extremely high levels of reliability, such as life-support systems, aircraft's control systems, or other applications whose failure can be reasonably expected to result in serious physical and/or material damage. Consult with your SANYO representative nearest you before using any SANYO products described or contained herein in such applications.

■ SANYO assumes no responsibility for equipment failures that result from using products at values that exceed, even momentarily, rated values (such as maximum ratings, operating condition ranges, or other parameters) listed in products specifications of any and all SANYO products described or contained herein.

**SANYO Electric Co.,Ltd. Semiconductor Company**

TOKYO OFFICE Tokyo Bldg., 1-10, 1 Chome, Ueno, Taito-ku, TOKYO, 110-8534 JAPAN

# LC7465M

## Block Diagram

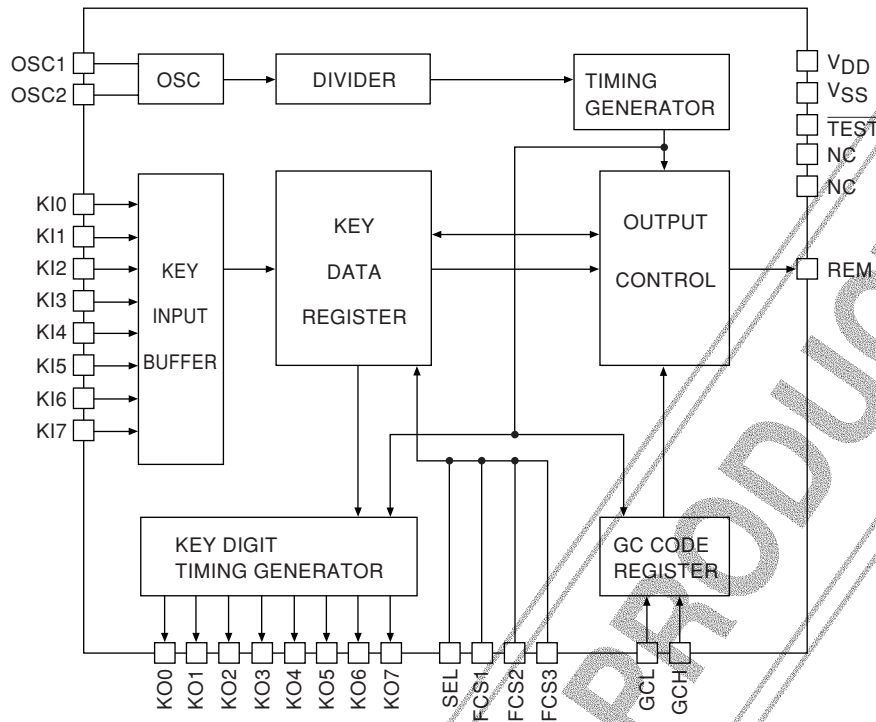

## Pin Description

Number	Name	Equivalent circuit	Description
1 to 8	K10 to K17		Keyswitch scanning inputs
9	REM		LED driver output
10	V <sub>DD</sub>		Supply voltage
11	TEST		Test input. TEST should be tied HIGH or left open for normal operation
12	OSC1		Ceramic oscillator input connection
13	OSC2		Ceramic oscillator output connection
14	V <sub>SS</sub>		Ground
15, 16	NC		No connection. Should be left open
17	SEL		Function code mode select inputs
18 to 20	FCS1 to FCS3		Function code select inputs
21	GCH		Product code select inputs
22	GCL		
23 to 30	KO0 to KO7		Keyswitch scanning outputs

# LC7465M

## Specifications

### Absolute Maximum Ratings at $T_a = 25^\circ\text{C}$

Parameter	Symbol	Conditions	Ratings	Unit
Maximum supply voltage	$V_{DD\text{ max}}$		$V_{SS}-0.3$ to $+5.5$	V
Input voltage	$V_I$		$V_{SS}-0.3$ to $V_{DD}+0.3$	V
Output voltage	$V_O$		$V_{SS}-0.3$ to $V_{DD}+0.3$	V
Output current	$I_O$		-35	mA
Allowable power dissipation	$P_d\text{ max}$	$T_a=85^\circ\text{C}$	150	mW
Operating temperature	$T_{opr}$		-40 to $+85$	$^\circ\text{C}$
Storage temperature	$T_{stg}$		-50 to $+125$	$^\circ\text{C}$

### Recommended Operating Conditions at $T_a = -40$ to $+85^\circ\text{C}$

Parameter	Symbol	Conditions	Ratings			Unit
			min	typ	max	
Supply voltage range	$V_{DD}$		2.0	3.0	3.6	V
KI0 to KI7, GCL, GCH, FCS1 to FCS3 and SEL input high-level voltage	$V_{IH}$		$0.7V_{DD}$		$V_{DD}$	V
KI0 to KI7, GCL, GCH, FCS1 to FCS3 and SEL input low-level voltage	$V_{IL}$		$V_{SS}$		$0.3V_{DD}$	V
Oscillator frequency	$f_{OSC}$		433	455	477	kHz

### Electrical Characteristics at $T_a = -40$ to $+85^\circ\text{C}$ , $V_{DD} = 2.0$ to $3.6\text{ V}$

Parameter	Symbol	Conditions	Ratings			Unit
			min	typ	max	
Operating supply current	$I_{DD}$	Key pressed, no load			1	mA
Standby supply current	$I_{DS}$	No key pressed, oscillator stopped			1	$\mu\text{A}$
REM output high-level current	$I_{OH}$	$V_{DD}=2\text{V}$ , $V_{OH}=V_{DD}-1\text{V}$ $V_{DD}=3\text{V}$ , $V_{OH}=V_{DD}-1\text{V}$		-2.5		mA
KO0 to KO7 output high-level voltage	$V_{OH}$	$I_{OH}=0.1\text{mA}$	$V_{DD}-0.3$			V
KO0 to KO7 and REM output low-level voltage	$V_{OL}$	$I_{OL}=0.1\text{mA}$			0.3	V
GCL, GCH and FCS1 to FCS3 input high-level current	$I_{IH}$	$V_I=V_{DD}$			1	$\mu\text{A}$
GCL, GCH and FCS1 to FCS3 input low-level current	$I_{IL}$	$V_I=V_{SS}$	-1			$\mu\text{A}$
KI0 to KI7 input floating voltage	$V_{IF}$				$0.1V_{DD}$	V
KI0 to KI7 input pull-down resistance	$R_{IN}$		75	100	125	$\text{k}\Omega$

DISCONTINUED PRODUCT

## Functional Description

### Key Inputs

An eight-by-eight matrix is formed with the keyswitch scanning outputs KO0 to KO7 and the keyswitch scanning inputs KI0 to KI7 as shown in the following figure. When a key is held down, either the normal or abbreviated continuation code is output continuously, depending on the mask option selected.

Normally, only one key can be pressed at a time. If more than one key is pressed, all keys are ignored and no output is generated. However, when the appropriate mask option is selected, seven function codes can be generated by holding down key 8 and one of keys 16, 24, 32, 40, 48, 56 and 64 as shown in table 1.

	KI0	KI1	KI2	KI3	KI4	KI5	KI6	KI7
KO0	1	9	17	25	33	41	49	57
KO1	2	10	18	26	34	42	50	58
KO2	3	11	19	27	35	43	51	59
KO3	4	12	20	28	36	44	52	60
KO4	5	13	21	29	37	45	53	61
KO5	6	14	22	30	38	46	54	62
KO6	7	15	23	31	39	47	55	63
KO7	8	16	24	32	40	48	56	64

Table 1. Function code generation

Key combination	Function code							
	FC0	FC1	FC2	FC3	FC4	FC5	FC6	FC7
8, 16	1	1	1	0	1	0	0	1
8, 24	1	1	1	0	0	1	0	1
8, 32	1	1	1	0	1	1	0	1
8, 40	1	1	1	0	0	0	1	1
8, 48	1	1	1	0	1	0	1	1
8, 56	1	1	1	0	0	1	1	1
8, 64	1	1	1	0	1	1	1	1

### Output Data Configuration

The 48-bit output data configuration is shown in the following figure. Note that the data is sent least-significant bit first.

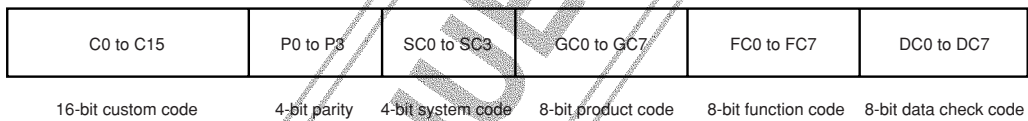

### Custom code

The 16-bit mask-programmable custom code (C0 to C15) is a unique code registered with the Association for Electric Home Appliances.

### Parity bits

The four parity bits (P0 to P3) are used for error detection. Their value is given by the following equation.

$$P_n = C_n \oplus C_{n+4} \oplus C_{n+8} \oplus C_{n+12}$$

where n=0 to 3.

### System code

The four-bit system code (SC0 to SC3) is mask-programmed into the LC7465M during fabrication.

### Product code

The eight-bit product code (GC0 to GC7) consists of two mask-programmable bits and six bits that are set by connecting each of GCL and GCH to one of KO0 to KO7. The block diagram of the product code generator is shown in the following figure. GC1 and GC3 are the mask-programmable bits, shown set to zero.

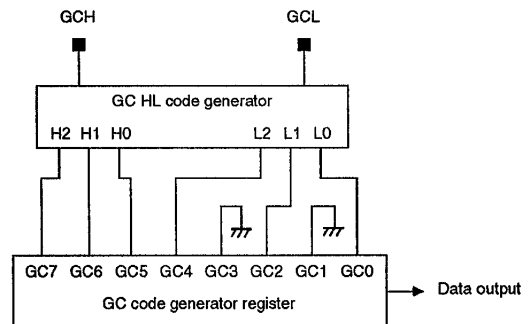

# LC7465M

Tables 2 and 3 show the relationships between GCL and L0 to L2, and between GCH and H0 to H2, respectively. Table 2. GCL product codes

Pin	Code generated		
	L0	L1	L2
KO0	0	0	0
KO1	1	0	0
KO2	0	1	0
KO3	1	1	0
KO4	0	0	1
KO5	1	0	1
KO6	0	1	1
KO7	1	1	1

Table 3. GCH product codes

Pin	Code generated		
	H0	H1	H2
KO0	0	0	0
KO1	1	0	0
KO2	0	1	0
KO3	1	1	0
KO4	0	0	1
KO5	1	0	1
KO6	0	1	1
KO7	1	1	1

## Function code

The eight-bit function code (FC0 to FC7) is determined by the number of the key pressed and the SEL and FCS1 to FCS3 inputs.

When SEL is LOW, bits FC3 and FC7 of the function codes for the 64 keys are determined by FCS1 and FCS3, respectively, as shown in tabel 4 and the following figure.

		Upper-level code (corresponds to KI)															
		0	1	2	3	4	5	6	7	8	9	A	B	C	D	E	F
Lower-level code (corresponds to KO)	0																
	1																
	2																
	3																
	4																
	5																
	6																
	7																
8																	
9																	
A																	
B																	
C																	
D																	
E																	
F																	

Diagram annotations: Arrows point from 'FCS1' to bit 3 and 'FCS3' to bit 7. Bit 3 is labeled '0 X' and bit 7 is labeled '0'. A '0 X 1' label is in the upper-right quadrant, and a '1 X 0' label is in the lower-left quadrant.

Table 4. Function code generation when SEL is LOW

FCS1	FCS2	FCS3	Function code							
			FC0	FC1	FC2	FC3	FC4	FC5	FC6	FC7
LOW	x	LOW	-	-	-	0	-	-	-	0
HIGH	x	LOW	-	-	-	1	-	-	-	0
LOW	x	HIGH	-	-	-	0	-	-	-	1
HIGH	x	HIGH	-	-	-	1	-	-	-	1

## Note

- x = don't care
- = key press code

The function codes when SEL is LOW, FCS1 is HIGH and FCS3 is LOW are shown in the following figure. For example, when key 23 is pressed, the generated function code is 2EH.

		0	1	2	3	4	5	6	7
Lower-level FC code	8	1	9	17	25	33	41	49	57
	9	2	10	18	26	34	42	50	58
	A	3	11	19	27	35	43	51	59
	B	4	12	20	28	36	44	52	60
	C	5	13	21	29	37	45	53	61
	D	6	14	22	30	38	46	54	62
	E	7	15	23	31	39	47	55	63
	F	8	16	24	32	40	48	56	64

Annotations: 'Upper-level FC code' points to the top row (0-7). 'Key numbers' points to the right side of the grid.

When SEL is HIGH, the function codes for keys 1 to 32 are fixed, and bits FC3, FC6 and FC7 of the function codes for keys 33 to 64 are determined by FCS1 to FCS3 as shown in table 5 and the following figure.

		Upper-level code (corresponds to KI)															
		0	1	2	3	4	5	6	7	8	9	A	B	C	D	E	F
Lower-level code (corresponds to KO)	0																
	1																
	2																
	3																
	4																
	5																
	6																
	7																
8																	
9																	
A																	
B																	
C																	
D																	
E																	
F																	

Diagram annotations: Arrows point from 'FCS1' to bit 3, 'FCS2' to bit 6, and 'FCS3' to bit 7. Bit 3 is labeled '0', bit 6 is labeled '1', and bit 7 is labeled '0'. A '001' label is in the upper-right quadrant, and a '011' label is in the lower-right quadrant.

# LC7465M

Table 5. Function code generation when SEL is HIGH

FCS1	FCS2	FCS3	Function code							
			FC0	FC1	FC2	FC3	FC4	FC5	FC6	FC7
LOW	LOW	LOW	-	-	-	0	-	-	1	0
HIGH	LOW	LOW	-	-	-	1	-	-	0	0
LOW	HIGH	LOW	-	-	-	0	-	-	1	0
HIGH	HIGH	LOW	-	-	-	1	-	-	1	0
LOW	LOW	HIGH	-	-	-	0	-	-	0	1
HIGH	LOW	HIGH	-	-	-	1	-	-	0	1
LOW	HIGH	HIGH	-	-	-	0	-	-	1	1
HIGH	HIGH	HIGH	-	-	-	1	-	-	1	1

**Note**

- = key press code

The function codes when SEL is HIGH, FCS1 is HIGH, FCS2 is LOW and FCS3 is HIGH are shown in the following figure. For example, when key 45 is pressed, the generated function code is 9CH.

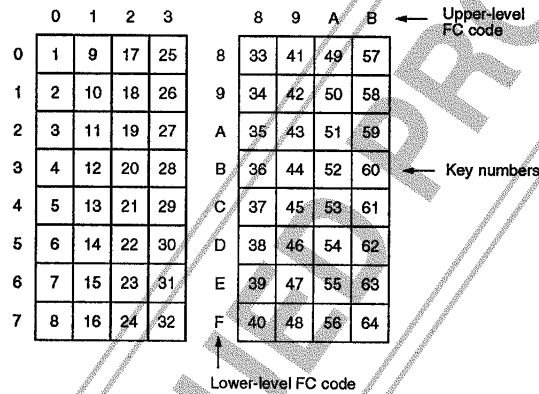

Note that when the appropriate mask option is selected, function codes 97H, A7H, B7H, C7H, D7H, E7H and F7H can also be generated by holding down key 8 and one of keys 16, 24, 32, 40, 48, 56 and 64.

**Data check code**

The eight-bit data check code (DC0 to DC7) is generated by adding the carry bits from the system code to the product and function code bits. This code is used for error detection. The data check code is calculated using the following equation.

$$DC = SC + GC0 \text{ to } GC3 + GC4 \text{ to } GC7 + FC0 \text{ to } FC3 + FC4 \text{ to } FC7$$

For example, when

$$SC = 0H, GC = 0B1H, FC = 35H$$

$$DC = 0H + 1H + 0BH + 5H + 3H = 14H$$

## Data Transmission Waveforms

### Abbreviated transmission mode

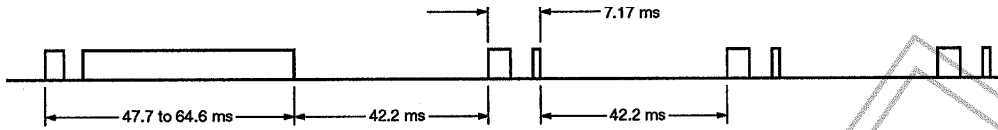

### Abbreviated mode detail

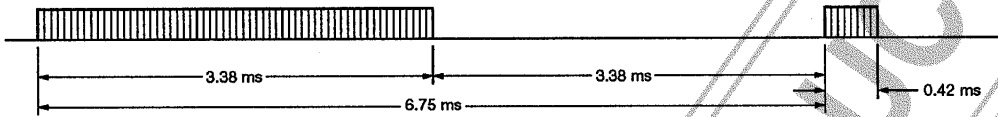

### Normal transmission mode

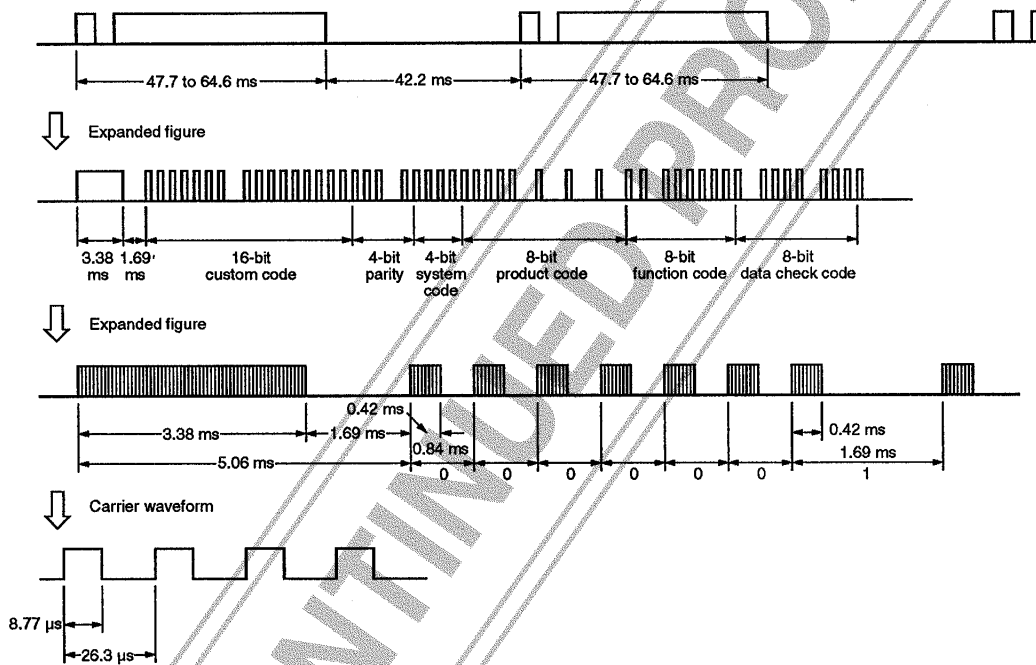

### Oscillator

The LC7465M contains a self-biased CMOS inverter that is used as an oscillator when connected to a ceramic resonator as shown in the following figure. To reduce power consumption, the oscillator operates only when a key is pressed.

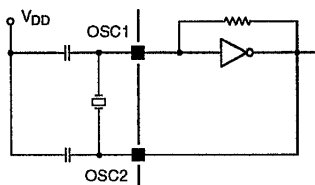

# LC7465M

## Typical Application

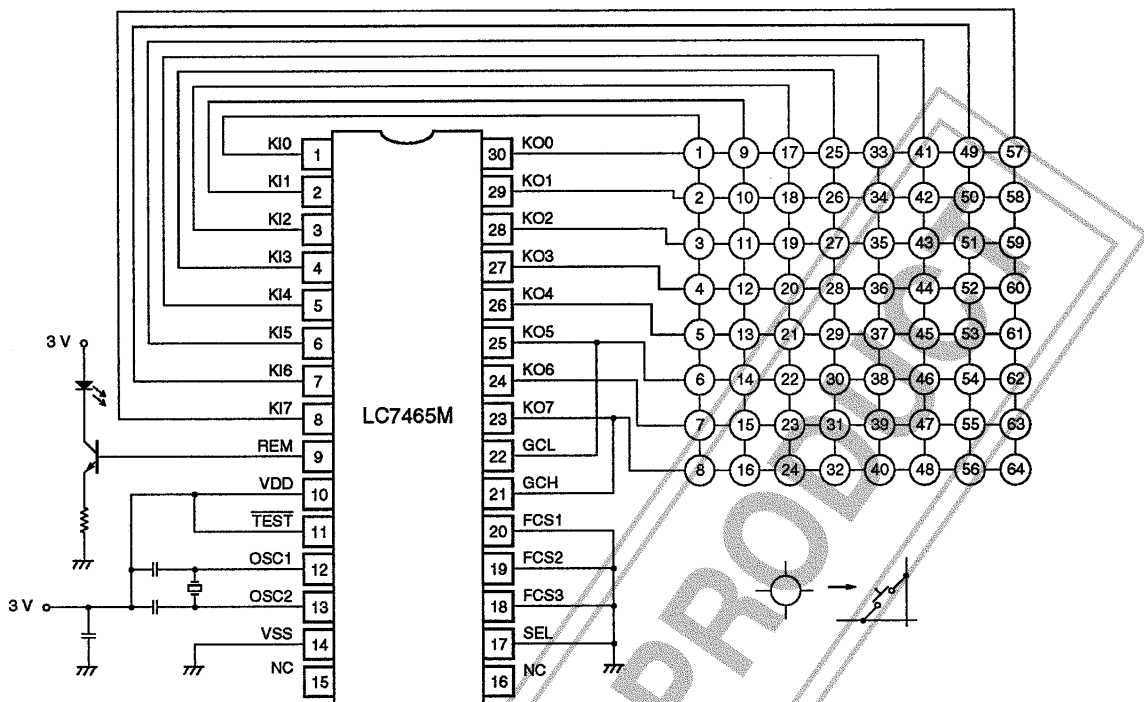

- Specifications of any and all SANYO products described or contained herein stipulate the performance, characteristics, and functions of the described products in the independent state, and are not guarantees of the performance, characteristics, and functions of the described products as mounted in the customer's products or equipment. To verify symptoms and states that cannot be evaluated in an independent device, the customer should always evaluate and test devices mounted in the customer's products or equipment.
- SANYO Electric Co., Ltd. strives to supply high-quality high-reliability products. However, any and all semiconductor products fail with some probability. It is possible that these probabilistic failures could give rise to accidents or events that could endanger human lives, that could give rise to smoke or fire, or that could cause damage to other property. When designing equipment, adopt safety measures so that these kinds of accidents or events cannot occur. Such measures include but are not limited to protective circuits and error prevention circuits for safe design, redundant design, and structural design.
- In the event that any or all SANYO products(including technical data, services) described or contained herein are controlled under any of applicable local export control laws and regulations, such products must not be exported without obtaining the export license from the authorities concerned in accordance with the above law.
- No part of this publication may be reproduced or transmitted in any form or by any means, electronic or mechanical, including photocopying and recording, or any information storage or retrieval system, or otherwise, without the prior written permission of SANYO Electric Co., Ltd.
- Any and all information described or contained herein are subject to change without notice due to product/technology improvement, etc. When designing equipment, refer to the "Delivery Specification" for the SANYO product that you intend to use.
- Information (including circuit diagrams and circuit parameters) herein is for example only ; it is not guaranteed for volume production. SANYO believes information herein is accurate and reliable, but no guarantees are made or implied regarding its use or any infringements of intellectual property rights or other rights of third parties.

This catalog provides information as of July, 2001. Specifications and information herein are subject to change without notice.