

Half-Bridge N-Channel MOSFET Driver for Motor Control

FEATURES

- 5-V Gate Drive
- Undervoltage Lockout
- Internal Bootstrap Diode
- Adaptive Shoot-Through Protection
- Motor Braking
- Shutdown Control
- Matched Rising and Falling Propagation Delays
- Drive MOSFETs In 4.5- to 50-V Systems



Pb-free
Available

APPLICATIONS

- H-Bridge Motor Controls
- 3-Phase Motor Controls

DESCRIPTION

The SiP42101 is a high-speed half-bridge MOSFET driver with adaptive shoot-through protection for motor driving applications. The high-side driver is bootstrapped to allow driving n-channel MOSFETs. The Brake pin forces the lowside MOSFET on, providing a braking function in H-bridge and 3-phase topologies.

The SiP42101 comes with adaptive shoot-through protection to prevent simultaneous conduction of the external MOSFETs.

The SiP42101 is available in both standard and lead (Pb)-free 10-Pin MLP33 packages and is specified to operate over the industrial temperature range of $-40\text{ }^{\circ}\text{C}$ to $85\text{ }^{\circ}\text{C}$.

FUNCTIONAL BLOCK DIAGRAM

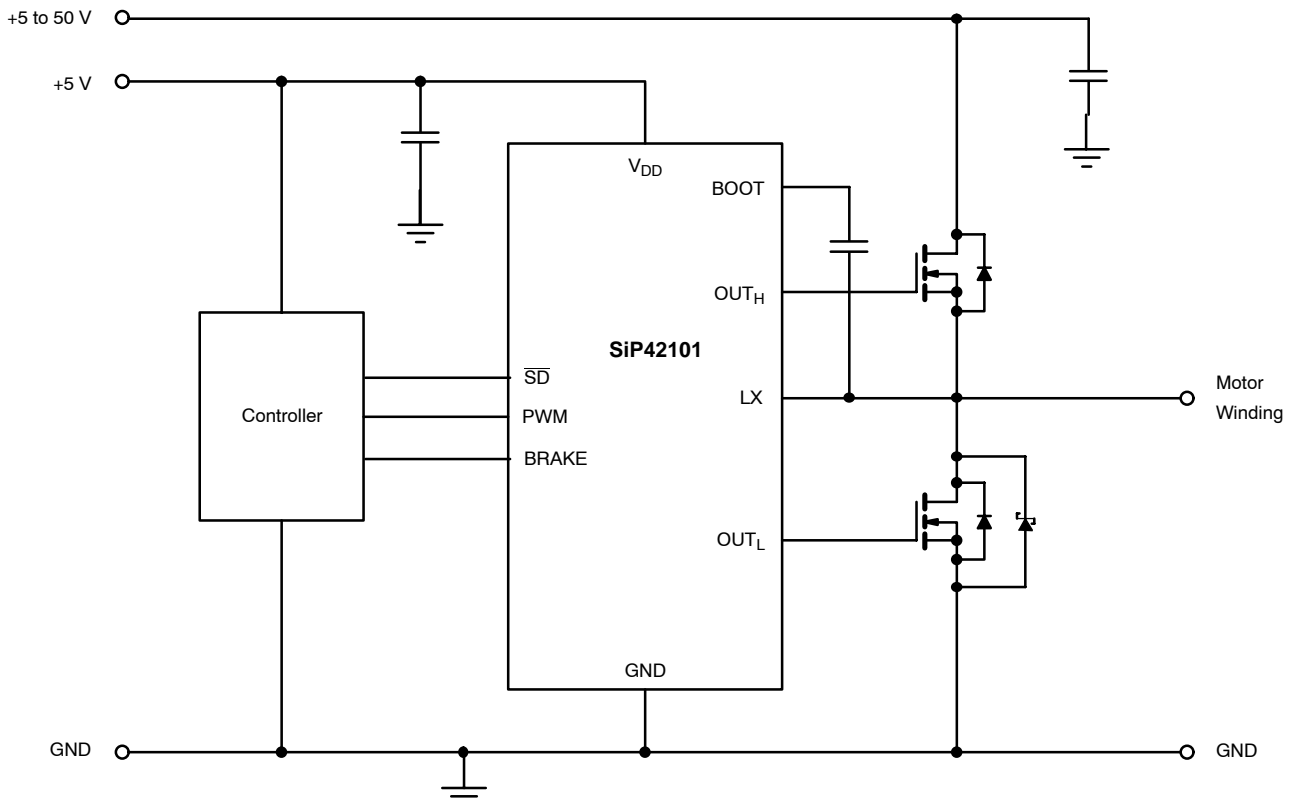

ABSOLUTE MAXIMUM RATINGS (ALL VOLTAGES REFERENCED TO GND = 0 V)

V_{DD} , PWM, \overline{SD} , BRAKE	7 V	Power Dissipation ^{a,b}	
LX, BOOT	55 V	MLP-33	960 mW
BOOT to LX	7 V	Thermal Impedance (Θ_{JA}) ^{a,b}	
Storage Temperature	-40 to 150°C	MLP-33	105°C/W
Operating Junction Temperature	125°C	Notes	
		a. Device mounted with all leads soldered or welded to PC board.	
		a. Derate 9.6 mW/°C	

Stresses beyond those listed under "Absolute Maximum Ratings" may cause permanent damage to the device. These are stress ratings only, and functional operation of the device at these or any other conditions beyond those indicated in the operational sections of the specifications is not implied. Exposure to absolute maximum rating conditions for extended periods may affect device reliability.

RECOMMENDED OPERATING RANGE (ALL VOLTAGES REFERENCED TO GND = 0 V)

V_{DD}	4.5 V to 5.5 V	C_{BOOT}	100 nF to 1 μ F
V_{BOOT}	4.5 V to 50 V	Operating Temperature Range	-40 to 85°C

SPECIFICATIONS ^a						
Parameter	Symbol	Test Conditions Unless Specified $V_{DD} = 5$ V, $V_{BOOT} - V_{LX} = 5$ V, $C_{LOAD} = 3$ nF $T_A = -40$ to 85°C	Limits			Unit
			Min ^a	Typ ^b	Max ^a	
Power Supplies						
Supply Voltage	V_{DD}		4.5		5.5	V
Quiescent Current	I_{DDQ}	$f_{PWM} = 1$ MHz, $C_{LOAD} = 0$		2.2	3.0	mA
Shutdown Current	I_{SD}				1	μ A
Reference Voltage						
Break-Before-Make	V_{BBM}			1		V
PWM Input						
Input High	V_{IH}		4.0		V_{DD}	V
Input Low	V_{IL}				0.5	
Bias Current	I_B			± 0.3	± 1	μ A
\overline{SD}, BRAKE Inputs						
Input High	V_{IH}		2.0		V_{DD}	V
Input Low	V_{IL}				1.0	
Bias Current	Brake \overline{SD}	I_B			± 1	μ A
				$\overline{SD} = 5$ V	3.5 7	
High-Side Undervoltage Lockout						
Threshold	V_{UVHS}	Rising or Falling	2.5	3.35	3.75	V
Bootstrap Diode						
Forward Voltage	V_F	$I_F = 10$ mA, $T_A = 25^\circ$ C	0.70	0.76	0.82	V
MOSFET Drivers						
High-Side Drive Current ^c	$I_{PKH(source)}$			0.9		A
	$I_{PKH(sink)}$			1.1		
Low-Side Drive Current ^c	$I_{PKL(source)}$			0.8		
	$I_{PKL(sink)}$			1.5		
High-Side Driver Impedance	$R_{DH(source)}$			2.5	3.8	Ω
	$R_{DH(sink)}$			2.2	3.3	
Low-Side Driver Impedance	$R_{DL(source)}$			3.4	5.1	
	$R_{DL(sink)}$			1.4	2.1	



SPECIFICATIONS ^a						
Parameter	Symbol	Test Conditions Unless Specified $V_{DD} = 5\text{ V}$, $V_{BOOT} - V_{LX} = 5\text{ V}$, $C_{LOAD} = 3\text{ nF}$ $T_A = -40\text{ to }85^\circ\text{ C}$	Limits			Unit
			Min ^a	Typ ^b	Max ^a	
MOSFET Drivers						
High-Side Rise Time	t_{rH}	10% – 90%		32	40	ns
High-Side Fall Time	t_{fH}	90% – 10%		36	45	
High-Side Propagation Delay ^c	$t_{d(off)H}$	See Timing Waveforms		20		
	$t_{d(on)H}$	See Timing Waveforms		30		
Low-Side Rise Time	t_{rL}	10% – 90%		45	55	
Low-Side Fall Time	t_{fL}	90% – 10%		20	30	
Low-Side Propagation Delay ^c	$t_{d(off)L}$	See Timing Waveforms		30		
	$t_{d(on)L}$	See Timing Waveforms		30		
LX Timer						
LX Falling Timeout ^c	t_{LX}			420		ns
V_{DD} Undervoltage Lockout						
Threshold Rising	V_{UVLOR}			4.35	4.5	V
Threshold Falling	V_{UVLOF}		3.7	4.1		
Hysteresis	V_H			0.4		
Power on Reset Time ^c				2.5		ms
Thermal Shutdown						
Temperature	T_{SD}	Temperature Rising		165		°C
Hysteresis	T_H	Temperature Falling		25		

Notes

- a. The algebraic convention whereby the most negative value is a minimum and the most positive a maximum (–40° to 85°C).
- b. Typical values are for DESIGN AID ONLY, not guaranteed nor subject to production testing and are measured at $V_{DD} = 5\text{ V}$ unless otherwise noted.
- c. Guaranteed by design.

TIMING WAVEFORMS

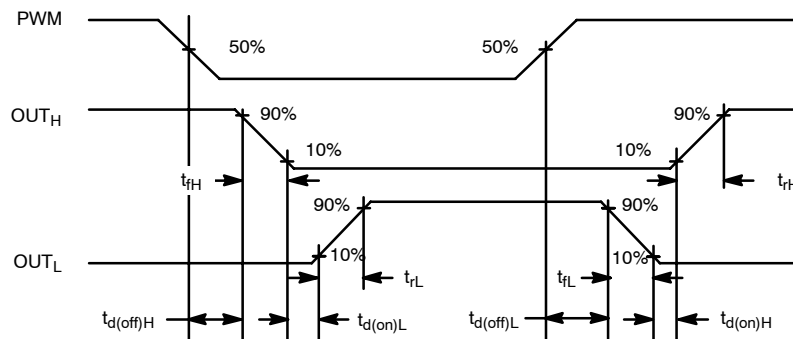

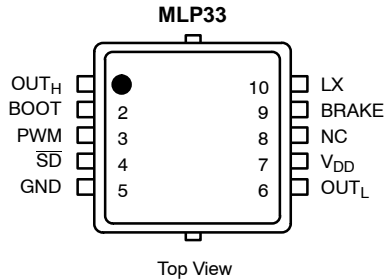
PIN CONFIGURATION AND TRUTH TABLE

TRUTH TABLE				
PWM	\overline{SD}	BRAKE	OUT _H	OUT _L
L	H	L	L	H
H	H	L	H	L
X	H	H	L	H
X	L	X	L	L

ORDERING INFORMATION

Standard Part Number	Lead(Pb)-Free Part Number	Temperature Range	Marking
SiP42101DM-T1	SiP42101DM-T1—E3	−40 to 85°C	42101

Eval Kit	Temperature Range
SiP42101DB	−40 to 85°C

PIN DESCRIPTION

Pin Number	Name	Function
1	OUT _H	High-side MOSFET gate drive
2	BOOT	Bootstrap supply for high-side driver. A capacitor connects between BOOT and LX.
3	PWM	Input signal for the MOSFET drivers
4	\overline{SD}	Shuts down the driver
5	GND	Ground
6	OUT _L	Synchronous or low-side MOSFET gate drive
7	V _{DD}	+5-V supply
8	NC	No Connect
9	BRAKE	Forces OUT _L high and OUT _H low
10	LX	Connection to source of high-side MOSFET, drain of the low-side MOSFET, and the inductor

FUNCTIONAL BLOCK DIAGRAM

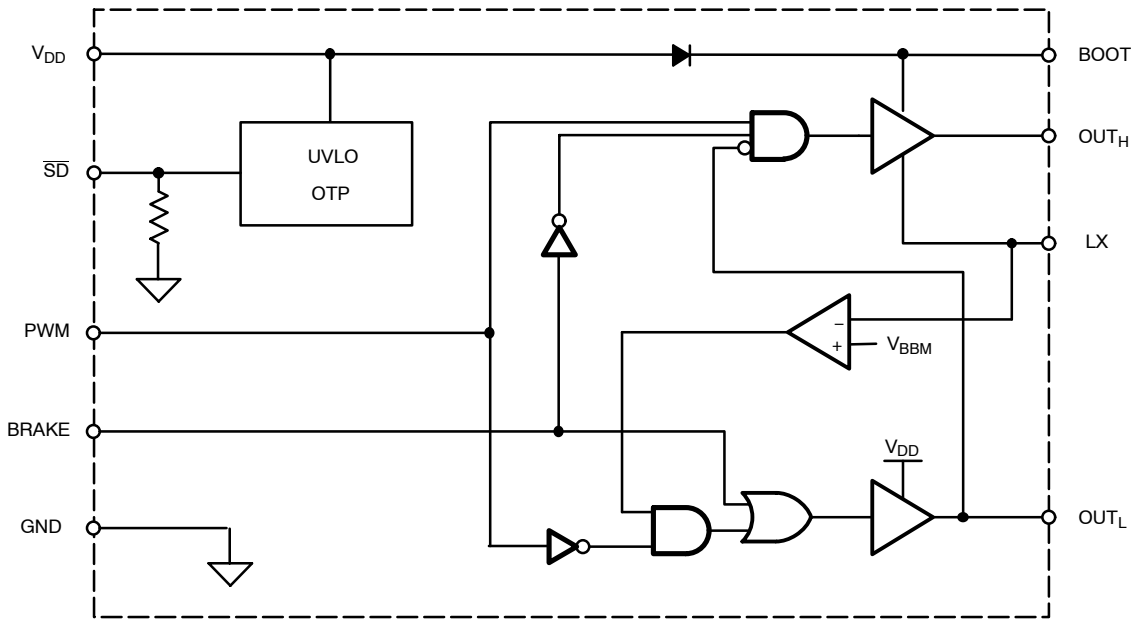

Figure 1.

DETAILED OPERATION

PWM

The PWM pin controls the switching of the external MOSFETs. The driver logic operates in a noninverting configuration. The PWM input stage should be driven by a signal with fast transition times, like those provided by a PWM controller or logic gate, (<200 ns). The PWM input functions as a logic input and is not intended for applications where a slow changing input voltage is used to generate a switching output when the input switching threshold voltage is reached.

Low-Side Driver

The supplies for the low-side driver are V_{DD} and GND. During shutdown, OUT_L is held low.

High-Side Driver

The high-side driver is isolated from the substrate to create a floating high-side driver so that an n-channel MOSFET can be used for the high-side switch. The supplies for the high-side driver are BOOT and LX. The voltage is supplied by a floating bootstrap capacitor, which is continually recharged by the switching action of the output. During shutdown OUT_H is held low.

Bootstrap Circuit

The internal bootstrap diode and a bootstrap capacitor form a charge pump that supplies voltage to the BOOT pin. An

integrated bootstrap diode replaces the external Schottky diode needed for the bootstrap circuit; only a capacitor is necessary to complete the bootstrap circuit. The bootstrap capacitor is sized according to,

$$C_{BOOT} = (Q_{GATE} / \Delta V_{BOOT - LX}) \times 10$$

where Q_{GATE} is the gate charge needed to turn on the high-side MOSFET and ΔV_{BOOT - LX} is the amount of droop allowed in the bootstrapped supply voltage when the high-side MOSFET is driven high. The bootstrap capacitor value is typically 0.1 μF to 1 μF. The bootstrap capacitor voltage rating must be greater than V_{DD} + 5 V to withstand transient spikes and ringing.

Shoot-Through Protection

The external MOSFETs are prevented from conducting at the same time during transitions. Break-before-make circuits monitor the voltages on the LX pin and the OUT_L pin and control the switching as follows: When the signal on PWM goes low, OUT_H will go low after an internal propagation delay. After the voltage on LX falls below 1 V by the inductor action, the low-side driver is enabled and OUT_L goes high after some delay. When the signal on PWM goes high, OUT_L will go low after an internal propagation delay. After the voltage on OUT_L drops below 1 V the high-side driver is enabled and OUT_H will go high after an internal propagation delay. If LX does not drop below 1 V within 400 ns after OUT_H goes low, OUT_L is forced high until the next PWM transition.



Matched Propagation Delays

Rising and falling propagation delays are matched from PWM to LX to within 8 ns.

Brake Input

When BRAKE is high, OUT_H is forced low and OUT_L is forced high to create active braking of the motor. When this input is low, operation is normal.

Shutdown

The driver enters shutdown mode when \overline{SD} is low. Shutdown current is less than 1 μA .

V_{DD} Bypass Capacitor

MOSFET drivers draw large peak currents from the supplies when they switch. A local bypass capacitor is required to

supply this current and reduce power supply noise. Connect a 1- μF ceramic capacitor as close as practical between the V_{DD} and GND pins.

Undervoltage Lockout

Undervoltage lockout prevents control of the circuit until the supply voltages reach valid operating levels. The UVLO circuit forces OUT_L and OUT_H to low when V_{DD} is below its specified voltage. A separate UVLO forces OUT_H low when the voltage between BOOT and LX is below the specified voltage.

Thermal Protection

If the die temperature rises above 165°C, the thermal protection disables the drivers. The drivers are re-enabled after the die temperature has decreased below 140°C.

TYPICAL CHARACTERISTICS

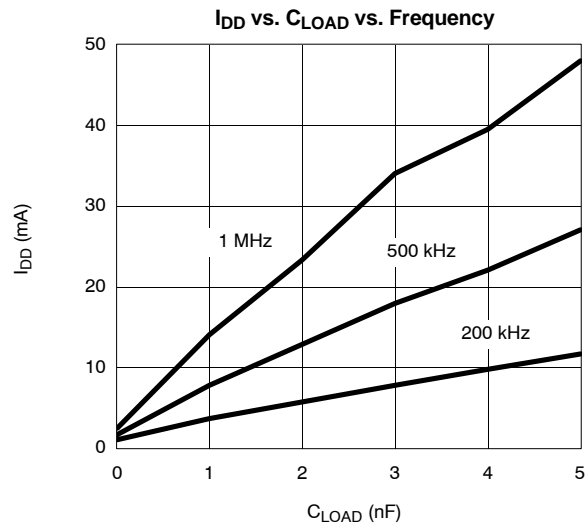

TYPICAL WAVEFORMS

Figure 2. PWM Signal vs. LX (Rising)

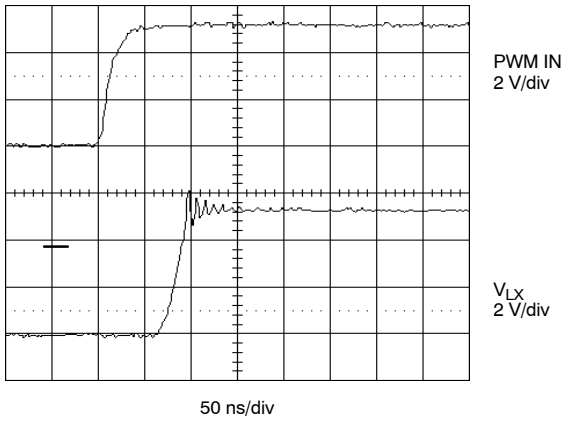

Figure 3. PWM Signal vs. LX (Falling)

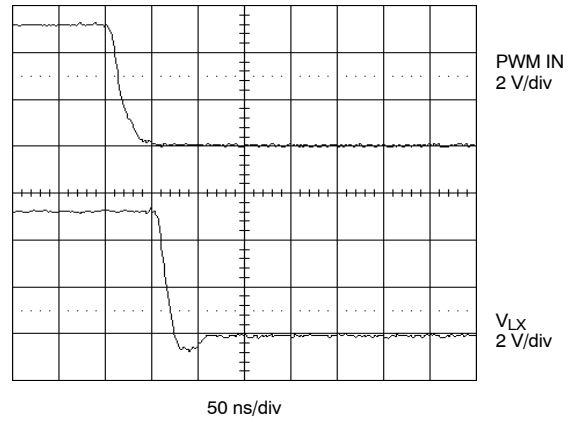

Figure 4. PWM Signal vs. HS Gate and LS Gate (Rising)

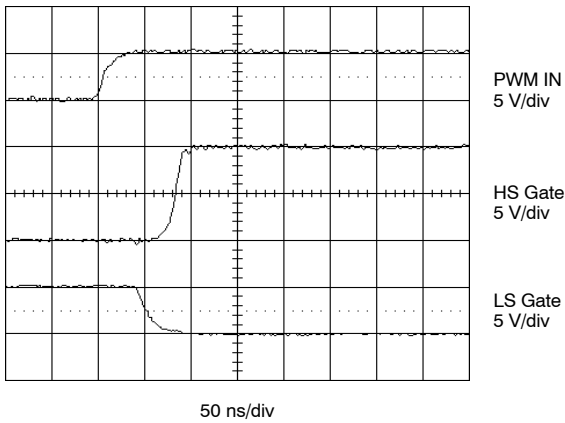

Figure 5. PWM Signal vs. HS Gate and LS Gate (Falling)

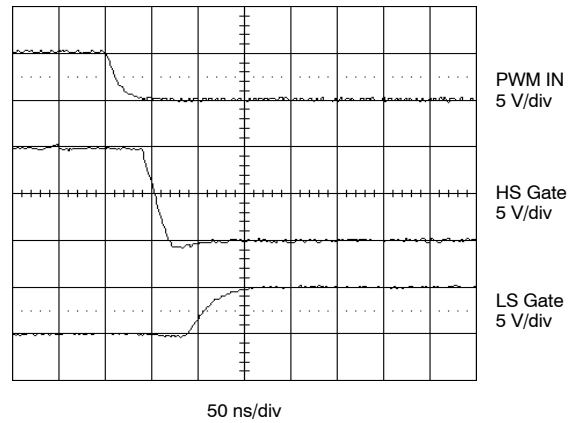
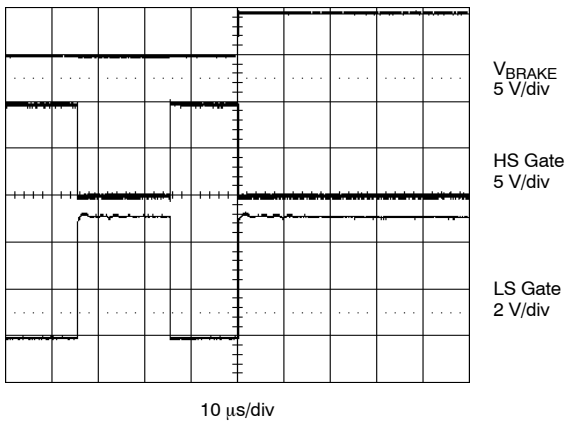

Figure 6. Brake Enable



Vishay Siliconix maintains worldwide manufacturing capability. Products may be manufactured at one of several qualified locations. Reliability data for Silicon Technology and Package Reliability represent a composite of all qualified locations. For related documents such as package/tape drawings, part marking, and reliability data, see <http://www.vishay.com/ppg?73176>.



Notice

Specifications of the products displayed herein are subject to change without notice. Vishay Intertechnology, Inc., or anyone on its behalf, assumes no responsibility or liability for any errors or inaccuracies.

Information contained herein is intended to provide a product description only. No license, express or implied, by estoppel or otherwise, to any intellectual property rights is granted by this document. Except as provided in Vishay's terms and conditions of sale for such products, Vishay assumes no liability whatsoever, and disclaims any express or implied warranty, relating to sale and/or use of Vishay products including liability or warranties relating to fitness for a particular purpose, merchantability, or infringement of any patent, copyright, or other intellectual property right.

The products shown herein are not designed for use in medical, life-saving, or life-sustaining applications. Customers using or selling these products for use in such applications do so at their own risk and agree to fully indemnify Vishay for any damages resulting from such improper use or sale.