

M52318SP/M52323SP

PLL-SPLIT VIF/SIF

DESCRIPTION

The M52318SP and M52323SP are IF signal-processing ICs for VCRs and color TVs. They enable the PLL detection system despite size as small as that of conventional quasi-synchronous VIF/SIF ICs.

The circuit includes VIF amplifier, video detector, VCO, APC detector, AFT, SIF detector, IF/RF AGC, SIF limiter, FM detector, QIF AGC, and EQ AMP.

FEATURES

- Video detection output is 2 V_{p-p}. It has built-in EQ AMP.
- The package is a 20-pin shrink-DIP, suitable for space saving.
- The video detector uses PLL for full synchronous detection circuit. It produces excellent characteristics of DG, DP, 920-kHz beat, and cross color.
- Dynamic AGC realizes high speed response with only single filter.
- Video IF and sound IF signal processings are separated from each other. VCO output is used to obtain Inter-carrier. This PLL-SPLIT method and built-in QIF AGC provide good sound sensitivity and reduces buzz.

APPLICATION

TV sets, VCR tuners

PIN CONFIGURATION (TOP VIEW)

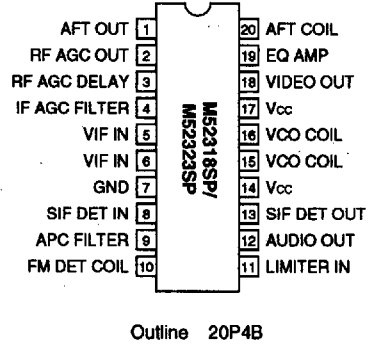

RECOMMENDED OPERATING CONDITION

Recommended supply voltage (pins ⑭, ⑰).....9V (12V)

Supply voltage range (pins ⑭, ⑰).....8 ~ 10V (11 ~ 13V)

() For M52323SP

BLOCK DIAGRAM

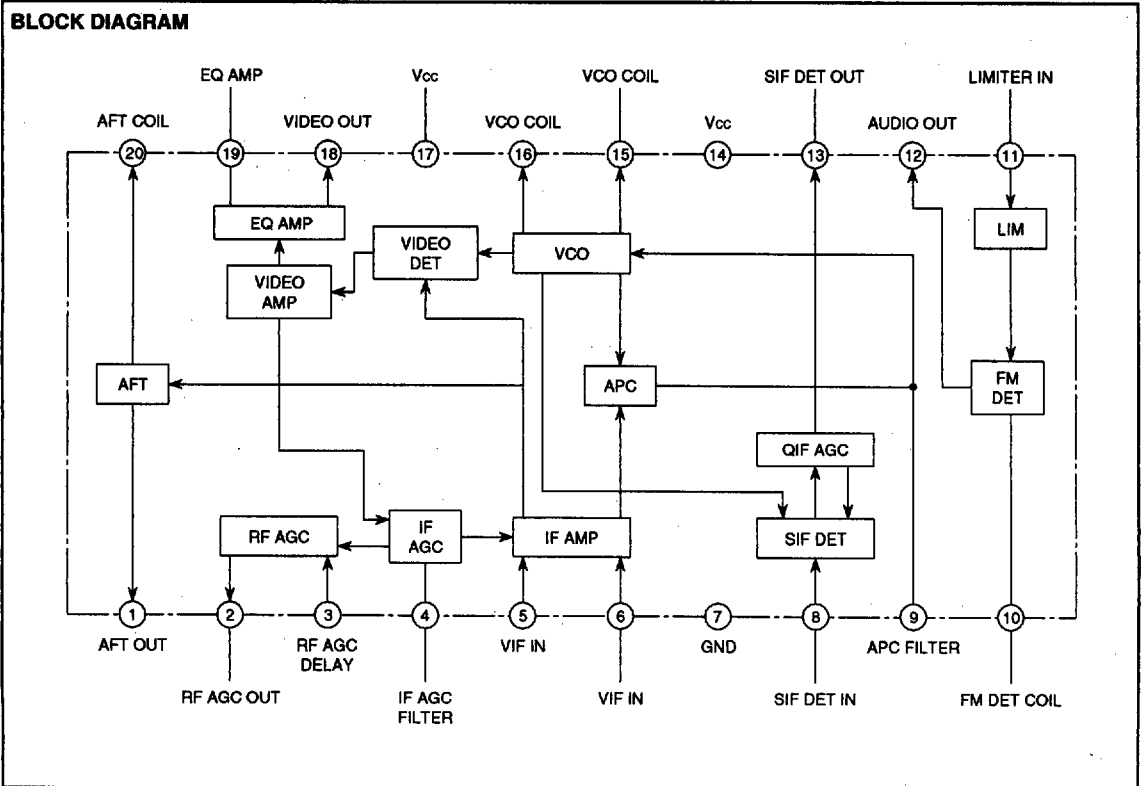

M52318SP/M52323SP

PLL-SPLIT VIF/SIF

ABSOLUTE MAXIMUM RATINGS

(Ta=25°C, For electrostatic discharge, capacitance is 200pF, snd resistance is 0Ω, unless otherwise noted.)

Symbol	Parameter	Test conditions	Ratings	Unit
Vcc	Supply voltage	Pins ⑭, ⑰	14	V
Pd	Power dissipation		1000	mW
Topt	Operating temperature		-20~+75	°C
Tstg	Storage temperature		-40~+125	°C
Surge	Electrostatic discharge		±200	V

ELECTRICAL CHARACTERISTICS (Ta=25°C, Vcc = 9(12)V unless otherwise noted.)

Symbol	Parameter	Test circuit	Test point	Input pin	Input SG	Test conditions			Limits			Unit
						External Power Supply		*Switch is usually set to 1.	Min.	Typ.	Max.	
						V3	V4					
Icc	Circuit current	1	A1	-	-	2	-	Vcc=9(12)V SW1=2	34	47	60	mA
V18	Video detection output DC voltage	1	TP18	-	-	2	0	SW4=2	6.1 (8.9)	6.7 (9.8)	7.3 (10.7)	V
V18det	Video detection output amplitude	1	TP18	IN1	SG1	2	-		1.98	2.2	2.42	Vp-p
S/N	Video S/N	1	TP18 LPF	IN1	SG2	2	-	SW18=2	52	57	-	dB
BW	Video detection output frequency characteristics	1	TP18	IN1	SG3	2	Variable	SW4=1→2	7.0	9.2	-	MHz
VIN (Min.)	Input sensitivity	1	TP18	IN1	SG4	2	-		-	44	49	dB μ
VIN (Max.)	Maximum allowable input	1	TP18	IN1	SG5	2	-		101	105	-	dB μ
GR	AGC control range	1	-	-	-	-	-		54	61	-	dB
V4H	IF AGC maximum voltage	1	TP4	-	-	2	-		4.8	5.6	-	V
V4 (80)	IF AGC voltage (80dB μ)	1	TP4	IN1	SG6	2	-		2.6	3.0	3.4	V
V4L	IF AGC minimum voltage	1	TP4	IN1	SG7	2	-		1.8	2.2	2.6	V
V2H	RF AGC maximum voltage	1	TP2	IN1	SG2	0	-		7.8 (10.8)	8.7 (11.7)	-	V
V2L	RF AGC minimum voltage	1	TP2	IN1	SG2	3	-		-	0.05	0.5	V
CL-U	Capture range U	1	TP18	IN1	SG8	2	-		0.6	1.1 (1.0)	-	MHz
CL-L	Capture range L	1	TP18	IN1	SG8	2	-		1.3 (1.2)	1.9 (1.7)	-	MHz
CL-T	Capture range T	1	-	-	-	-	-		2.2 (2.0)	3.0 (2.7)	-	MHz
V1	AFT output voltage	1	TP1	-	-	2	0	SW4=2	3.0 (4.0)	4.1 (5.4)	5.2 (6.8)	V
μ	AFT detection sensitivity	1	TP1	IN1	SG9	2	-		48	70	-	mV/kHz
V1H	AFT maximum voltage	1	TP1	IN1	SG10	2	-		8.0 (11.0)	8.7 (11.7)	-	V
V1L	AFT minimum voltage	1	TP1	IN1	SG10	2	-		-	0.2	1.0	V
V1 defeat	AFT defeat voltage	1	TP1			2	-	SW20=2	4.05 (5.4)	4.5 (6.0)	4.95 (6.6)	V
IM	Intermodulation	1	TP18	IN1	SG11	2	Variable	SW4=2	30	35	-	dB
DG	DG	1	TP18	IN1	SG12	2	-		-	2	5	%
DP	DP	1	TP18	IN1	SG12	2	-		-	2	5	deg
V18 - SYNC	Sync tip level	1	TP18	IN1	SG2	2	-		3.3 (6.1)	4.0 (7.3)	4.7 (8.5)	V

() For M52323SP

ELECTRICAL CHARACTERISTICS (cont.)

Symbol	Parameter	Test circuit	Test point	Input pin	Input SG	Test conditions			Limits			Unit
						External Power Supply		*Switch is usually set to 1.	Min.	Typ.	Max.	
						V3	V4					
RINV	VIF input resistance	2	⑥PIN						—	0.9	—	kΩ
CINV	VIF input capacitance	2	⑥PIN						—	5.6	—	pF
RINS	SIF input resistance	2	⑧PIN						—	1.1	—	kΩ
CINS	SIF input capacitance	2	⑧PIN						—	5.4	—	pF
V13-80	SIF detector output 4.5 MHz amplitude (80 dB μ)	1	TP13	IN1 IN2	SG2 SG13	2	—		94	99	104	dB μ
V13-100	SIF detector output 4.5 MHz amplitude (100 dB μ)	1	TP13	IN1 IN2	SG2 SG14	2	—		94	99	104	dB μ
V12	AF output DC voltage	1	TP12	—	—	2	—		4.1(5.3)	4.7(6.1)	5.3(6.9)	V
V12 MUTE	AF mute voltage	1	TP12	—	—	2	—	SW10=2	3.9(5.5)	4.4(6.0)	4.9(6.5)	V
V12 MAX	AF output maximum amplitude	1	TP12	IN3	SG15	2	—		200	270	340	mV r.m.s
THD AF	AF output distortion	1	TP12	IN3	SG15	2	—		—	0.4	1.2	%
LIN (Min)	Input limiting sensitivity	1	TP12	IN3	SG16	2	—		—	49	55	dB μ
AMR	AMR	1	TP12	IN3	SG17	2	—		44	53	—	dB
S/N	AF S/N	2	TP12	IN3	SG18	2	—		60	70	—	dB

ELECTRICAL CHARACTERISTICS TEST METHODS

S/N

Input signals of SG2 to VIF input (IN1) pin. Measure TP18-LPF noise in root-mean-square, from video detection output (Pin ⑧) through a low-pass filter of 5 MHz (-3dB).

$$S/N = 20 \log \left(\frac{0.7 \times V_{18 \text{ det}}}{\text{NOISE}} \right) \text{ dB}$$

BW

- Input signals of SG3 to VIF Input (IN1) pin (set f2 to 57.75 MHz). Using a spectrum analyzer, measure 1 MHz component level at video detection output (TP18). At the same time, measure voltage at TP4. Set SW4 to 2. Adjust and fix V4 to the TP4 voltage.
- Decrease f2. Measure f2-f0 difference when f2-f0 component level is -3dB with reference to the 1 MHz component level.

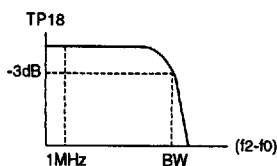

VIN (Min.)

Input SG4 (Vi = 90 dB μ) to VIF input (IN1) pin. Gradually reduce Vi. When 20kHz component of video detection output (TP18) falls to -3 dB with reference to the V18 det, measure the input level.

VIN (Max.)

- Input SG5 (Vi = 90 dB μ) to VIF input (IN1) pin. Measure 20 kHz component level of video detection output.
- Gradually increase Vi. When the output falls to -3 dB, measure the input level.

GR

$$GR = VIN(\text{Max.}) - VIN(\text{Min.}) \text{ (dB)}$$

CL-U

- Increase SG8 frequency to let VCO unlocked.
- Gradually reduce SG8 frequency. When VCO is locked, measure the frequency as fU.

$$CL-U = fU - 58.75(\text{MHz})$$

M52318SP/M52323SP

PLL-SPLIT VIF/SIF

CL-L

1. Reduce SG8 frequency to let VCO unlocked.
2. Gradually increase SG8 frequency. When VCO is locked, measure the frequency as fL.

$$CL-L = 58.75 - f_L \text{ (MHz)}$$

CL-T

$$CL-T = CL-U + CL-L \text{ (MHz)}$$

μ , V_{1H} , V_{1L}

1. Adjust AFT coil to 58.75 MHz. (See the section "Adjusting Coils.")
2. Input SG9 to VIF input (IN1) pin. Set SG9 frequency so that AFT output (TP1) voltage can be 6 V (8V). f(6) is this frequency.
3. Set SG9 frequency so that AFT output (TP1) voltage can be 3 V (4 V). f(3) is this frequency.

$$\mu = \frac{(4000)}{f(3) - f(6)} \frac{3000 \text{ (mV)}}{\text{(mV / kHz)}} \text{ (mV / kHz)}$$

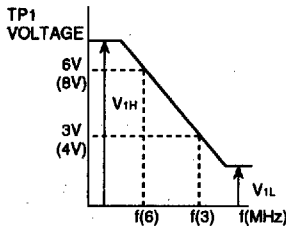

4. In the figure on this page, V_{1H} is the maximum DC voltage, and V_{1L} is the minimum DC voltage.

ADJUSTING COILS

a. VCO coil

Make VIF input (IN1) zero. Connect AGC filter (TP4) to GND. Measure APC filter voltage (VDCAPC). After that, input 58.75 MHz CW of 90 dB μ to VIF input (IN1) pin. Adjust APC filter voltage to VDCAPC.

b. AFT coil

Input $f = 58.75$ MHz CW of 90dB μ to VIF input (IN1) pin. Adjust the coil so that AFT output (TP1) voltage can be about $V_{cc}/2 = 4.5$ V (6.0 V).

c. FM DET coil

1. Connect FM DET coil pin (TP10) through 10k Ω resistor to GND. Measure audio output (TP12) voltage.
2. Input $f = 4.5$ MHz CW of 90 dB μ to limiter input (IN3) pin. Adjust the coil to produce the previous audio output (TP12).

IM

1. Input SG11 to VIF input (IN1) pin. Observe video detection output (TP18) on the oscilloscope.
2. Adjust AGC filter voltage (V4) so that the minimum DC level of the output waveform can be 4 V (7.2 V).
3. Observe TP18 on the spectrum analyzer. Intermodulation is the ratio of 920 kHz component level to 3.58 MHz component level.

LIM (Min.)

1. Input SG16 ($V_i = 90$ dB μ) to limiter input (IN3) pin. Measure 1 kHz component level at audio output (TP12).
2. Gradually decrease SG16 input level V_i . When 1 kHz component level at audio output falls to -3 dB with reference to the previous level, measure the SG16 level.

AMR

1. Input SG17 to limiter input (IN3) pin. Measure audio output (TP12) level. VAM is this level.

$$2. \text{ AMR} = 20 \log \left(\frac{V_{12 \text{ Max. (mV r.m.s)}}}{V_{AM} \text{ (mV r.m.s)}} \right) \text{ (dB)}$$

S/N

1. Input SG18 to limiter input (IN3) pin. Measure audio output (TP12) level. V_N is this level.

$$2. \text{ S/N} = 20 \log \left(\frac{V_{12 \text{ Max. (mV r.m.s)}}}{V_N \text{ (mV r.m.s)}} \right) \text{ (dB)}$$

INPUT SIGNALS

SG No.	fo(MHz)	AM Modulation %	FM Modulation (kHz/dev)	Modulation Frequency (kHz)	Vi(dB μ)	Remark
①	58.75	77.78	—	20	90	
②	58.75	—	—	—	90	
③	58.75	—	—	—	90	MIXED SIGNAL
	Variable	—	—	—	70	
④	58.75	77.78	—	20	Variable	
⑤	58.75	16	—	20	Variable	
⑥	58.75	—	—	—	80	
⑦	58.75	—	—	—	120	
⑧	Variable	77.78	—	20	90	
⑨	58.75 \pm 0.1	—	—	—	90	
⑩	58.75 \pm 5	—	—	—	90	
⑪	58.75	—	—	—	90	MIXED SIGNAL
	55.17	—	—	—	80	
	54.25	—	—	—	80	
⑫	58.75	87.5 Video modulation	—	—	90 Sync tip label	Ten-stage modulation as standard
⑬	54.25	—	—	—	80	
⑭	54.25	—	—	—	100	
⑮	4.5	—	\pm 25	1.0	90	
⑯	4.5	—	\pm 25	1.0	Variable	
⑰	4.5	30	—	1.0	90	
⑱	4.5	—	—	—	90	

M52318SP/M52323SP

PLL-SPLIT VIF/SIF

TEST CIRCUIT 1

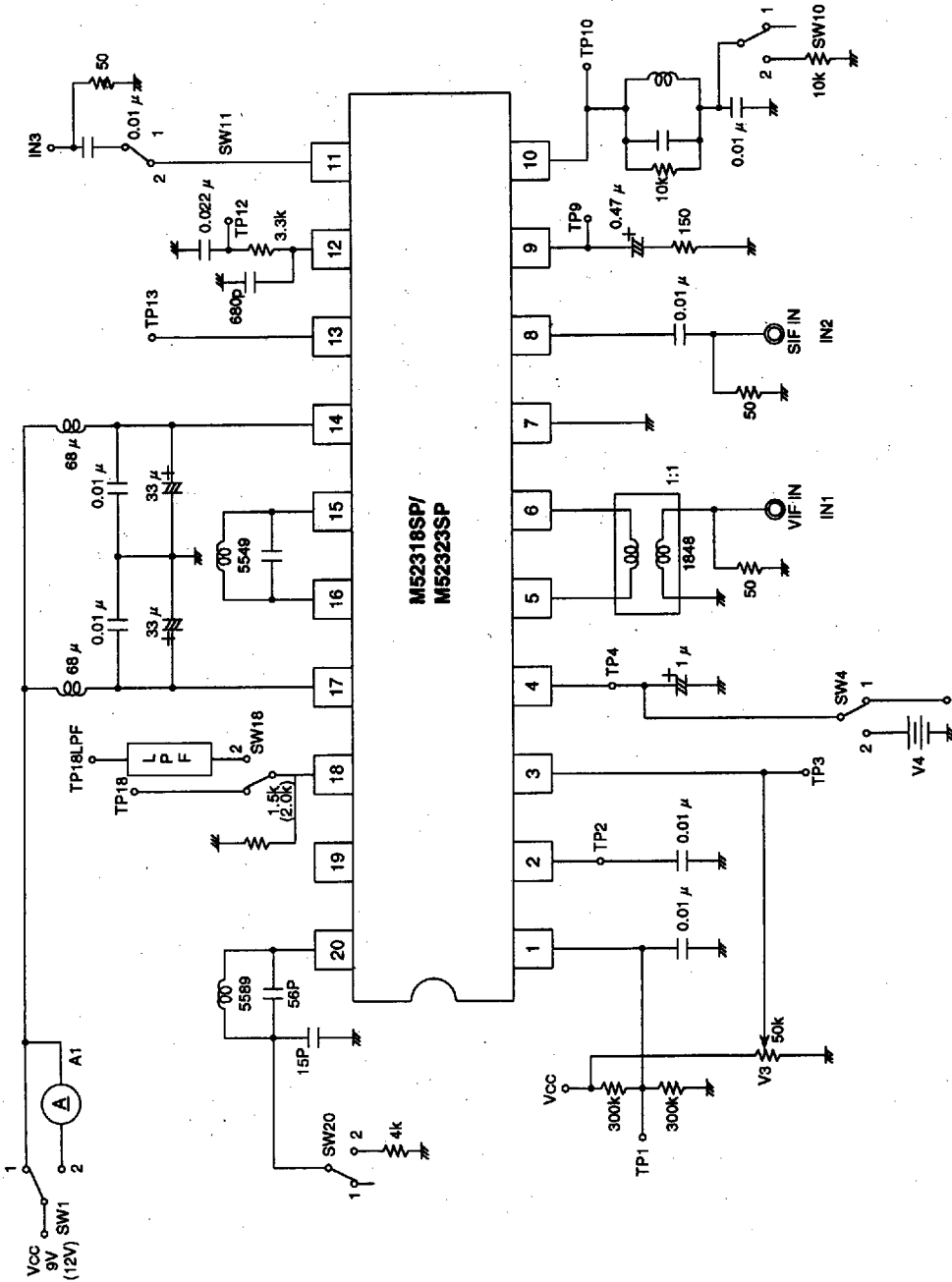

Units Resistance: Ω
 Capacitance: F
 Reactance: H

TEST CIRCUIT 2

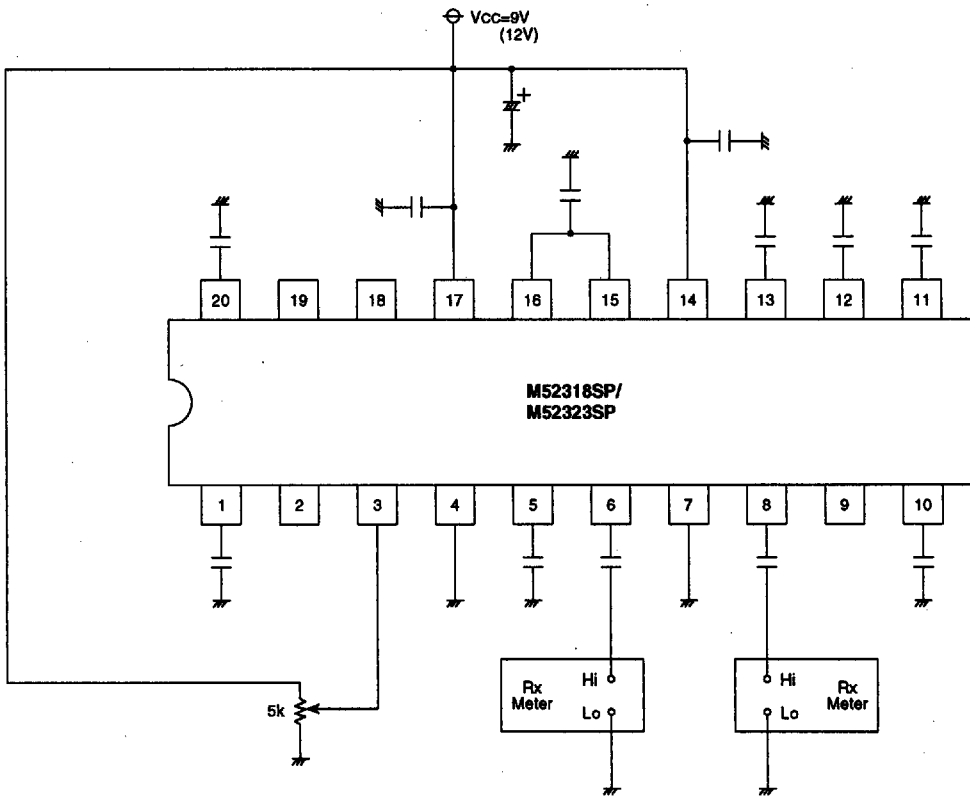

Capacitors of 0.01 μ Fare used unless noted otherwise.

Units Resistance: Ω

Capacitance: F

TYPICAL CHARACTERISTICS

THERMAL DERATING (MAXIMUM RATING)

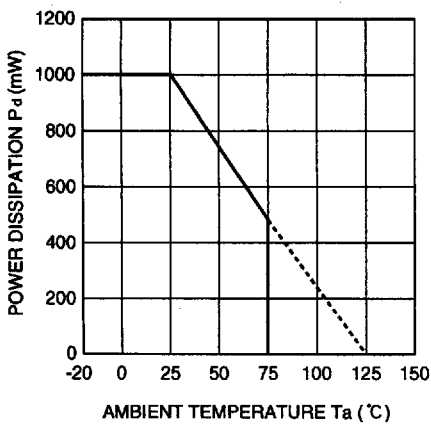

APPLICATION EXAMPLE

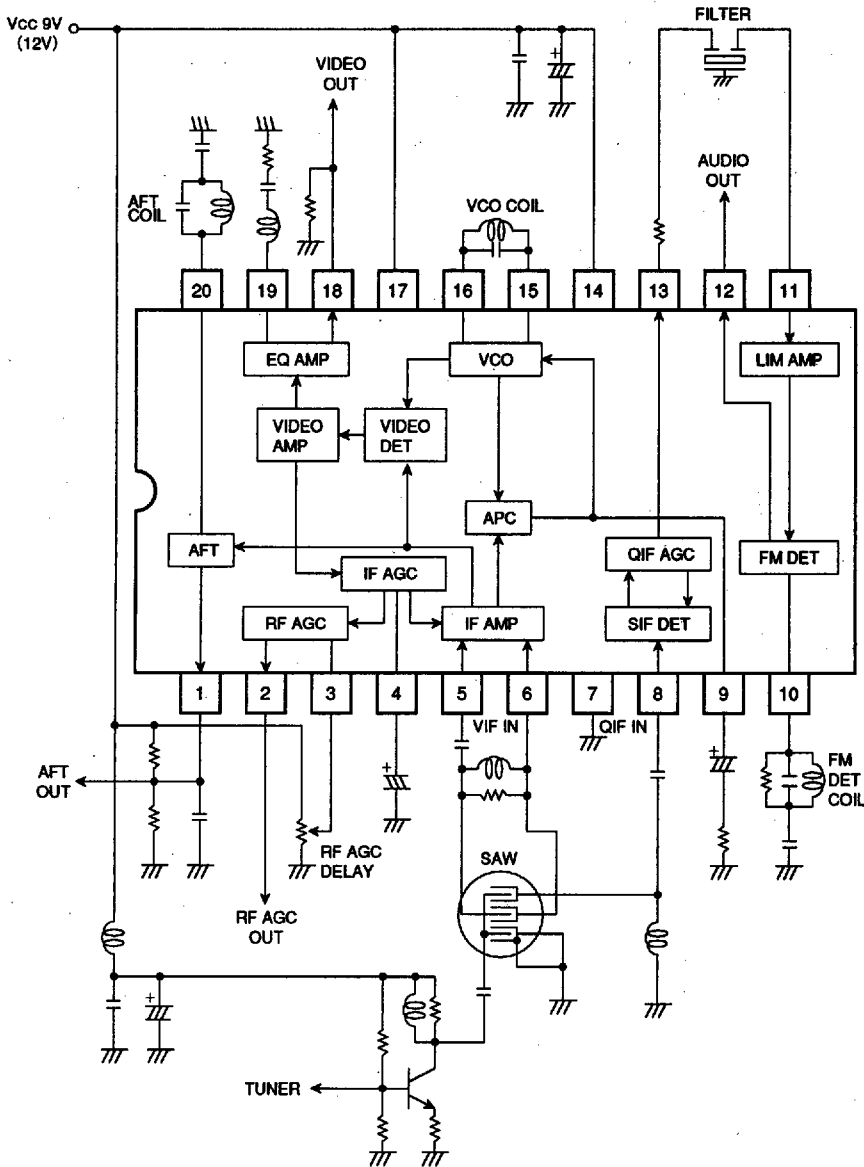

DESCRIPTION OF PIN (cont.)

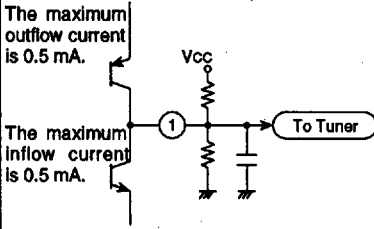
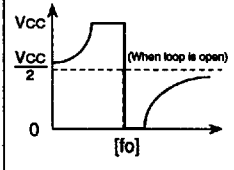
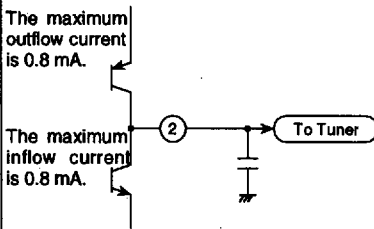
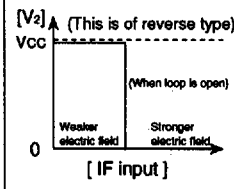
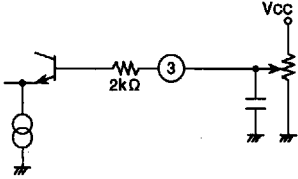
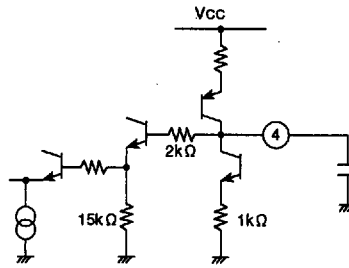
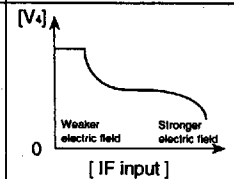
Pin No.	Name	Voltage and wave information	Peripheral circuit of pins	Description of function
①	AFT OUT	4.5V (6.0V)	<p>The maximum outflow current is 0.5 mA.</p> <p>The maximum inflow current is 0.5 mA.</p> 	<p>AFT output has high impedance. External resistors can be used to determine detection sensitivity.</p> 
②	RF AGC OUT	—	<p>The maximum outflow current is 0.8 mA.</p> <p>The maximum inflow current is 0.8 mA.</p> 	 <p>(This is of reverse type)</p>
③	RF AGC DELAY	—		<p>Voltage can be applied to this pin to change AGC delay point.</p>
④	IF AGC FILTER	—		 <p>Dynamic AGC circuit enables ①-pin filter to produce characteristics equivalent to those of ②-pin filter.</p>

DESCRIPTION OF PIN (cont.)

Pin No.	Name	Voltage and wave information	Peripheral circuit of pins	Description of function
⑤ ⑥	VIF IN	—		Design the circuit to enable impedance matching with SAW filter.
⑦	GND	0V	—	Pin ⑦ is the only GND pin of this IC.
⑧	SIT DET IN	—		Input impedance is 1.5 kΩ.
⑨	APC FILTER	—		<p>In the locked state, usually adjust frequency response with external resistors so that cut-off frequency can be in the range of 30 ~ 100 kHz.</p>
⑩	FM DET COIL	—		FM detector performs quadrature detection. Connect pin ⑩ to GND through a DC-cutting capacitor connected in series with tank coil. Instead of coil, ceramic discriminator can be used. Connecting this pin to GND makes sound mute.

DESCRIPTION OF PIN (cont.)

Pin No.	Name	Voltage and wave information	Peripheral circuit of pins	Description of function
⑪	LIMITER IN	—		Input impedance is 1.5 kΩ.
⑫	AUDIO OUT	—		This is audio output pin. This output has a series resistor of 500 Ω.
⑬	SIT DET OUT	—		Emitter follower produces this output.
⑭	Vcc	9V(12V)	—	—
⑮ ⑯	VCO COIL	—		Connecting a coil and a capacitor with these pins enables oscillation. This oscillator must be used with oscillation frequency adjusted to fo. Since oscillation evolves to high level, it might interfere other pins, and cause malfunctions of VCO in the pull-in process. For these pins, lay out the external printed-circuit pattern compact enough to prevent interference.
⑰	Vcc	9V(12V)	—	—

M52318SP/M52323SP

PLL-SPLIT VIF/SIF

DESCRIPTION OF PIN (cont.)

Pin No.	Name	Voltage and wave information	Peripheral circuit of pins	Description of function
18	EQ OUT	—		<p>Output voltage swings positive. Video modulation of 87.5% produces output of 2.2 V_{P-P}.</p>
19	VIDEO OUT	—		<p>External circuit can be connected with this pin to determine frequency characteristics of EQ output. Connecting pin 18 through a resistor to pin 19 can reduce EQ output amplitude.</p>
20	AFT COIL	—		<p>Connecting this pin to GND enables mute function to make AFT mute.</p>