

# M51571L

MITSUBISHI ELEK (LINEAR)

## PICTURE-IN-PICTURE SOUND SWITCHING

### DESCRIPTION

The M51571L is packed in a 20-pin plastic zigzag in-line package. With use of this circuit, the VCR sound processing circuit becomes smaller, because it has a built-in picture-in-picture sound switching circuit and AGC circuit and does not need many external parts.

### FEATURES

- Picture-in-picture sound switch
- Built-in AGC circuit
- Output pins having two types of gains for NTSC and PAL.
- Single power source; references for compatibility with two sources (positive/negative)

### APPLICATIONS

Video cassette recorders and Hi-Fi video cassette recorders

### RECOMMENDED OPERATING CONDITIONS

Supply voltage ..... 12V  
 Rated supply voltage ..... 11~13V

### PIN CONFIGURATION (TOP VIEW)

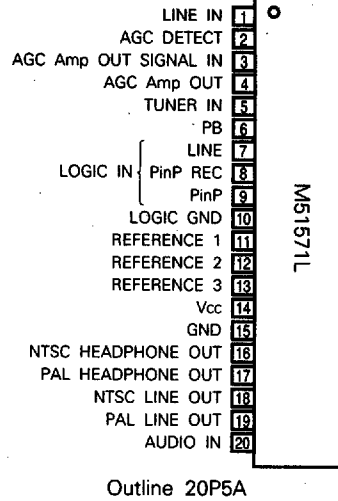

### BLOCK DIAGRAM

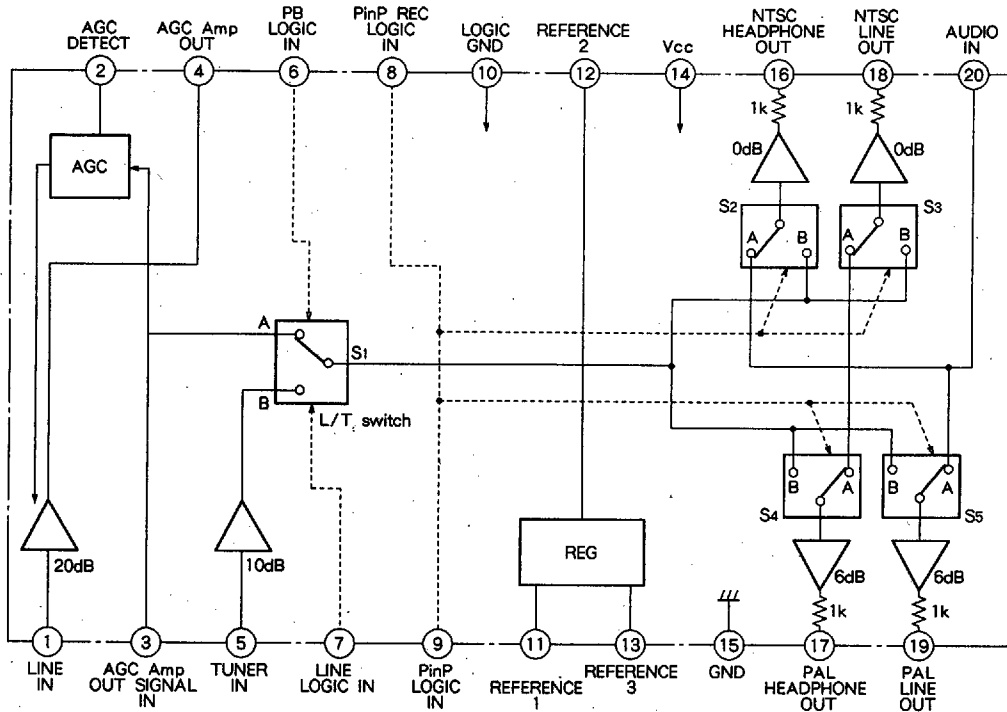

MITSUBISHI ELEK (LINEAR)

PICTURE-IN-PICTURE SOUND SWITCHING

ABSOLUTE MAXIMUM RATINGS

Symbol	Parameter	Ratings	Unit
V <sub>cc</sub>	Supply voltage	15	V
I <sub>cc</sub>	Circuit current	50	mA
P <sub>d</sub>	Internal power dissipation	800	mW
K <sub>θ</sub>	Thermal derating	8	mW/°C
T <sub>opr</sub>	Operating temperature	-20~75	°C
T <sub>stg</sub>	Storage temperature	-40~125	°C

ELECTRICAL CHARACTERISTICS (T<sub>a</sub> = 25°C, unless otherwise noted)

Symbol	Parameter	Test conditions	Limits			Unit
			Min.	Typ.	Max.	
I <sub>cco</sub>	PB mode no - signal circuit current	No signal	11	18	25	mA
V <sub>OLP</sub>	PAL line system output signal level	V <sub>in</sub> = -28dBs	-5.0	-3.0	-1.0	dBs
THD <sub>LP</sub>	PAL line system distortion rate	V <sub>in</sub> = -28dBs, 400Hz HPF, 30kHz LPF	*	0.2	0.5	%
N <sub>OLP</sub>	PAL line system output noise	R <sub>g</sub> = 2kΩ, BW = 20Hz~20kHz	*	-75	-69	dBs
V <sub>OTP</sub>	PAL line system output signal level	V <sub>in</sub> = -18dBs	-3.5	-2.0	-0.5	dBs
THD <sub>TP</sub>	PAL tuner system distortion rate	V <sub>in</sub> = -18dBs, 400Hz, 30kHz LPF	*	0.05	0.2	%
N <sub>OTP</sub>	PAL tuner system output noise	R <sub>g</sub> = 2kΩ, BW = 20Hz~20kHz	*	-90	-84	dBs
V <sub>OAP</sub>	PAL AUD system output signal level	V <sub>in</sub> = -8dBs	-4.6	-3.6	-2.6	dBs
THD <sub>AP</sub>	PAL AUD system distortion rate	V <sub>in</sub> = -8dBs, 400Hz HPF, 30kHz LPF	*	0.05	0.2	%
N <sub>OAP</sub>	PAL AUD system output noise	R <sub>g</sub> = 2kΩ, BW = 20Hz~20kHz	*	-90	-84	dBs
V <sub>OLN</sub>	NTSC line system output signal level	V <sub>in</sub> = -28dBs	-11.0	-9.0	-7.0	dBs
THD <sub>LNOFF</sub>	NTSC line system distortion rate	V <sub>in</sub> = -28dBs, 400Hz HPF, 30kHz LPF	*	0.2	0.5	%
N <sub>OLN</sub>	NTSC line system output noise	R <sub>g</sub> = 2kΩ, BW = 20Hz~20kHz	*	-80	-74	dBs
V <sub>OTN</sub>	NTSC Tuner system output signal level	V <sub>in</sub> = -18dBs	-9.5	-8.0	-6.5	dBs
THD <sub>TN</sub>	NTSC Tuner system distortion rate	V <sub>in</sub> = -18dBs, 400Hz HPF, 30kHz LPF	*	0.05	0.2	%
N <sub>OTN</sub>	NTSC Tuner system output noise	R <sub>g</sub> = 2kΩ, BW = 20Hz~20kHz	*	-90	-84	dBs
V <sub>OAN</sub>	NTSC AUD system output signal level	V <sub>in</sub> = -8dBs	-10.6	-9.6	-8.6	dBs
THD <sub>AN</sub>	NTSC AUD system distortion rate	V <sub>in</sub> = -8dBs, 400Hz HPF, 30kHz LPF	*	0.05	0.2	%
N <sub>OAN</sub>	NTSC AUD system output noise	R <sub>g</sub> = 2kΩ, BW = 20Hz~20kHz	*	-90	-84	dBs
V <sub>H</sub>	Logic "H" retention voltage	Voltage applied when mode is switched	1.8	*	V <sub>cc</sub>	V
V <sub>L</sub>	Logic "L" retention voltage	Voltage applied when mode is switched	GND	*	0.8	V

ELECTRICAL CHARACTERISTICS TEST METHOD

Symbol	⑥ PB	⑦ line	⑧ PinP REV	⑨ PinP	SW <sub>2</sub>	SW <sub>3</sub>	SW <sub>4</sub>	Measuring procedure	Note
I <sub>cco</sub>	H	H	H	H	2	2	2	Read the current circuit with ammeter 1 during PB, with no signal being sent.	
V <sub>OL</sub>	H	H	H L	H	1	2	2	Measure output signal level during line input.	1
THD <sub>L</sub>	H	H	H L	H	1	2	2	Measure output distortion rate during line input.	1
N <sub>OL</sub>	H	H	H L	H	2	2	2	BW = 20Hz~20kHz	1
V <sub>OT</sub>	H	L	H L	H	2	1	2	Measure output signal level during tuner input.	1
THD <sub>T</sub>	H	L	H L	H	2	1	2	Measure output distortion rate during tuner input.	1
N <sub>OT</sub>	H	L	H L	H	2	2	2	BW = 20Hz~20kHz	1
V <sub>OAN</sub>	H	H	L	L	2	2	1	Measure output signal level during AUD input.	
THD <sub>AN</sub>	H	H	L	L	2	2	1	Measure output distortion rate during AUD input.	
N <sub>OAN</sub>	H	H	L	L	2	2	2	BW = 20Hz~20kHz	

Note 4 H, 5 V; L, 0 V.

Note 5 Pin ⑧: When PinP REV is "H," line out; "L" H.P. out

MITSUBISHI ELEK (LINEAR)

M51571L

PICTURE-IN-PICTURE SOUND SWITCHING

Mode switch table

⑥ PB	⑦ Line	S <sub>1</sub>	Remark
L	L	A	Line
L	H	A	Line
H	L	B	Tuner
H	H	A	Tuner

⑧ PinP REV	⑨ PinP	S <sub>2</sub>	S <sub>3</sub>	S <sub>4</sub>	S <sub>5</sub>	Remark
L	L	A	A	A	A	Normal
L	H	B	A	B	A	PinP
H	L	A	A	A	A	Normal
H	H	A	B	A	B	PinP REV

Note 6: H, 5V; L, 0V

TEST CIRCUIT

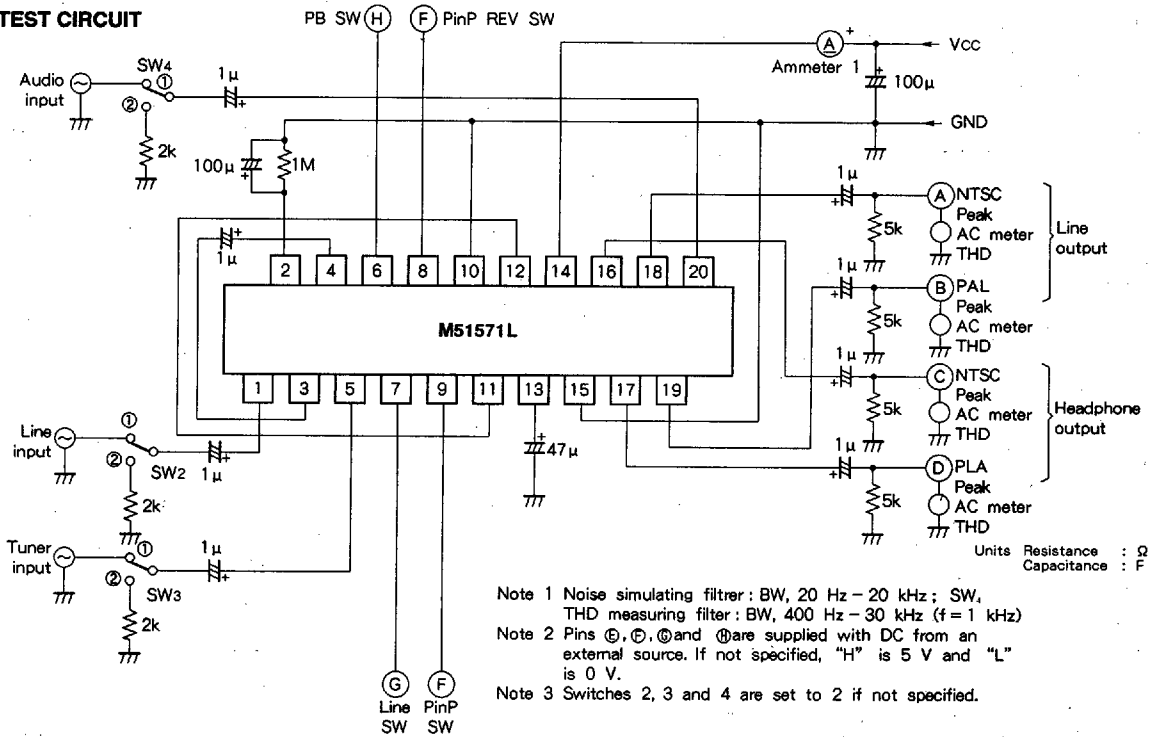

- Note 1 Noise simulating filter: BW, 20 Hz - 20 kHz; SW, THD measuring filter: BW, 400 Hz - 30 kHz (f = 1 kHz)
- Note 2 Pins ⑥, ⑨, ⑩ and ⑪ are supplied with DC from an external source. If not specified, "H" is 5 V and "L" is 0 V.
- Note 3 Switches 2, 3 and 4 are set to 2 if not specified.

TYPICAL CHARACTERISTICS

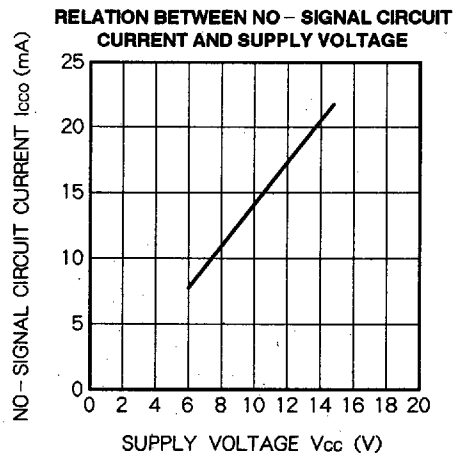
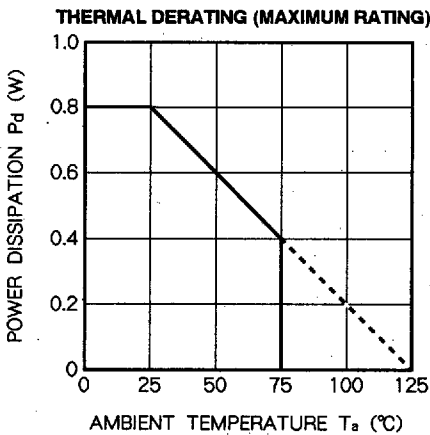

MITSUBISHI ELEK (LINEAR)

PICTURE-IN-PICTURE SOUND SWITCHING

RELATION BETWEEN PAL LINE OUTPUT VOLTAGE AND INPUT VOLTAGE

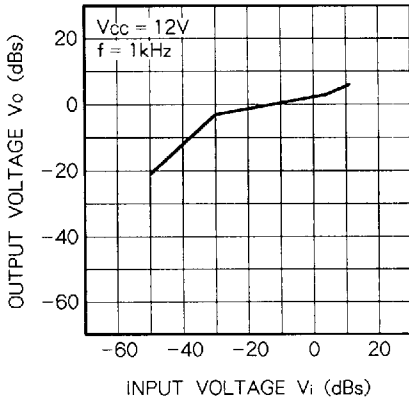

RELATION BETWEEN PAL LINE DISTORTION RATE AND INPUT VOLTAGE

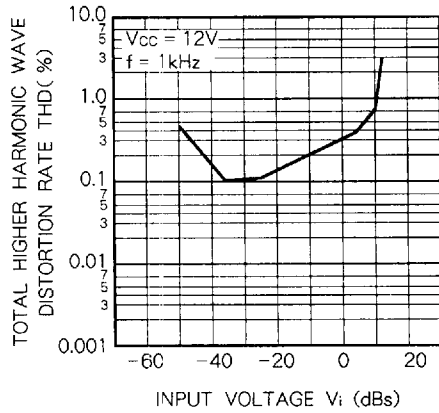

RELATION BETWEEN PAL TUNER OUTPUT VOLTAGE AND INPUT VOLTAGE

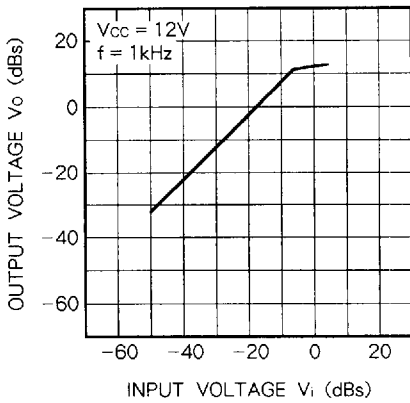

RELATION BETWEEN PAL TUNER DISTORTION RATE AND INPUT VOLTAGE

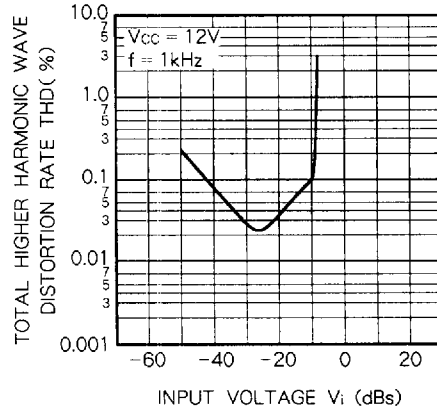

RELATION BETWEEN PAL AUD OUTPUT VOLTAGE AND INPUT VOLTAGE

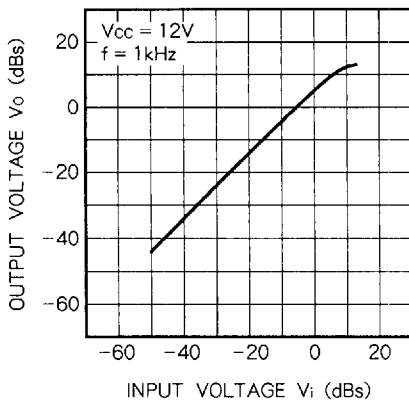

RELATION BETWEEN PAL AUD DISTORTION RATE AND INPUT VOLTAGE

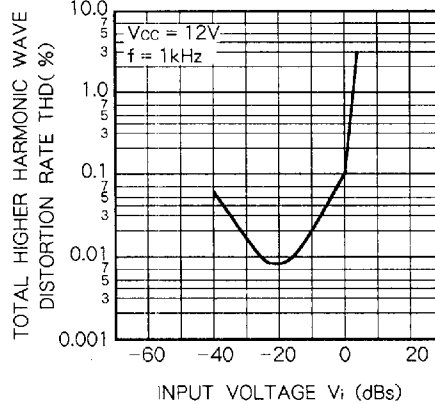

MITSUBISHI ELEK (LINEAR)

PICTURE-IN-PICTURE SOUND SWITCHING

RELATION BETWEEN NTSC LINE OUTPUT VOLTAGE AND INPUT VOLTAGE

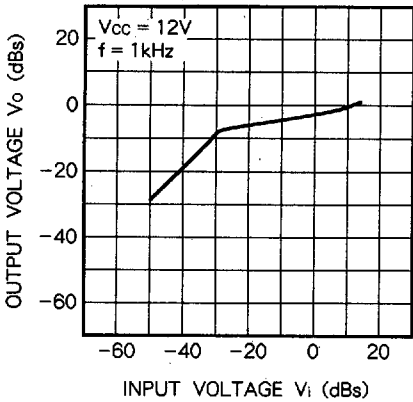

RELATION BETWEEN NTSC LINE DISTORTION RATE AND INPUT VOLTAGE

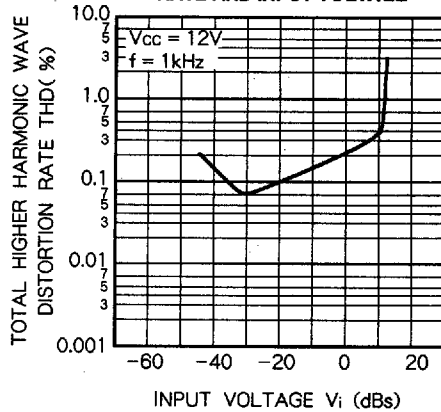

RELATION BETWEEN NTSC TUNER OUTPUT VOLTAGE AND INPUT VOLTAGE

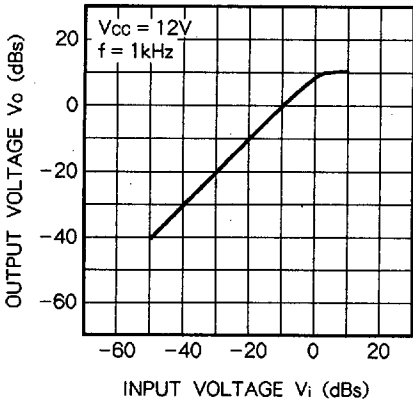

RELATION BETWEEN PAL TUNER DISTORTION RATE AND INPUT VOLTAGE

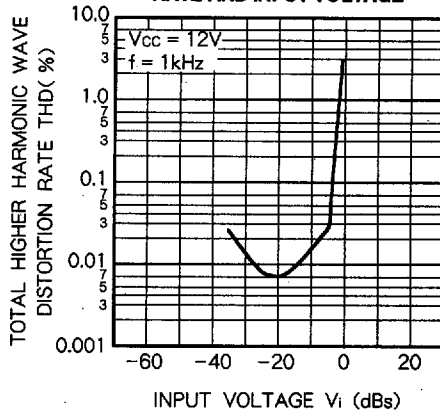

RELATION BETWEEN NTSC AUD OUTPUT VOLTAGE AND INPUT VOLTAGE

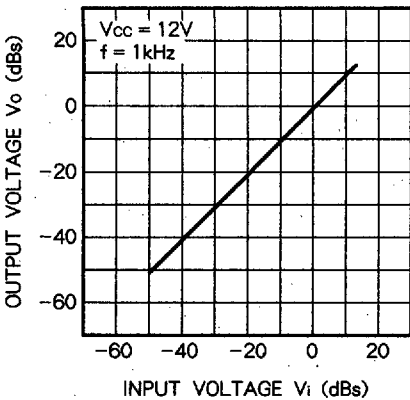

RELATION BETWEEN NTSC AUD DISTORTION RATE AND INPUT VOLTAGE

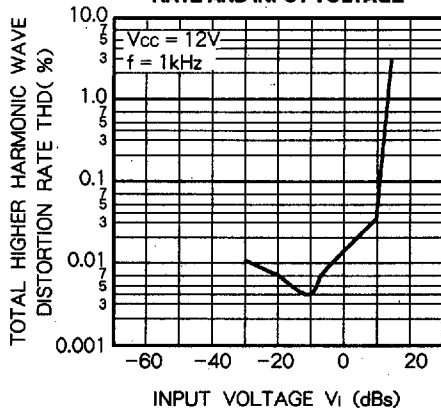

MITSUBISHI ELEK (LINEAR)

PICTURE-IN-PICTURE SOUND SWITCHING

APPLICATION EXAMPLE 1

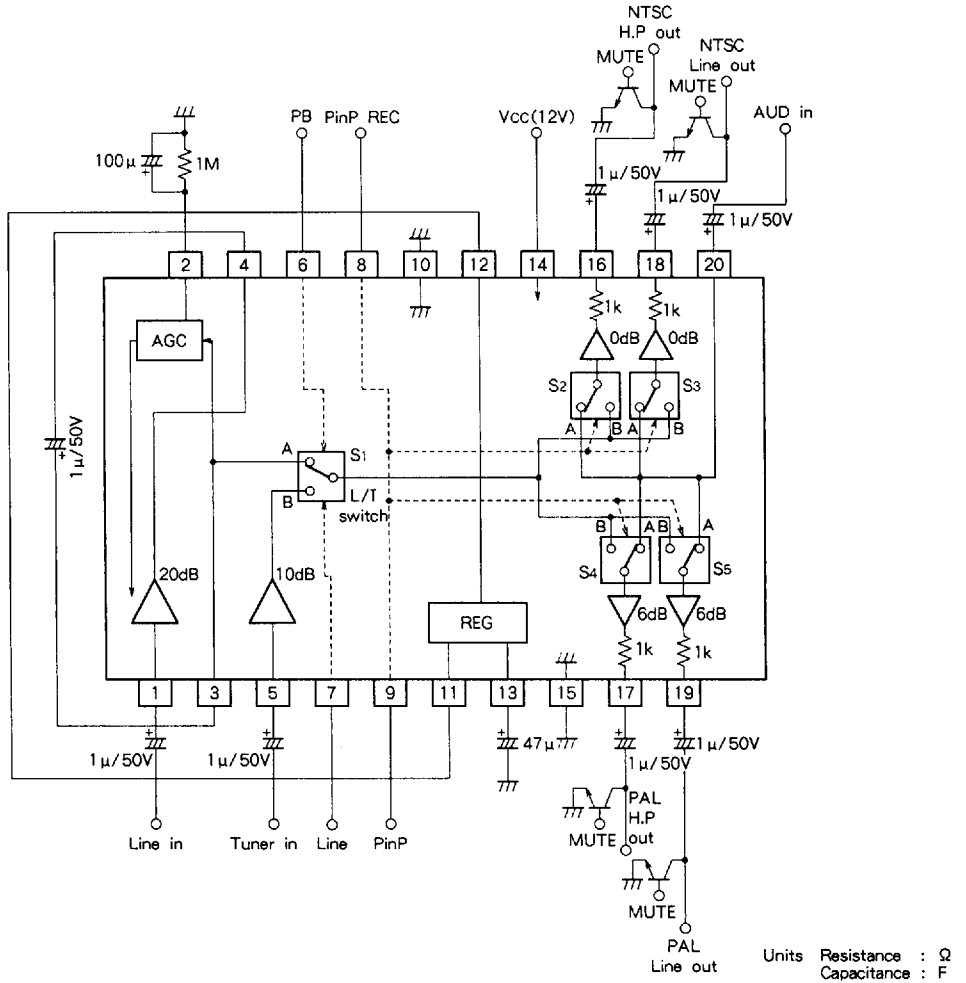

MITSUBISHI ELEK (LINEAR)

M51571L

PICTURE-IN-PICTURE SOUND SWITCHING

APPLICATION EXAMPLE 2 (±6 V power supply)

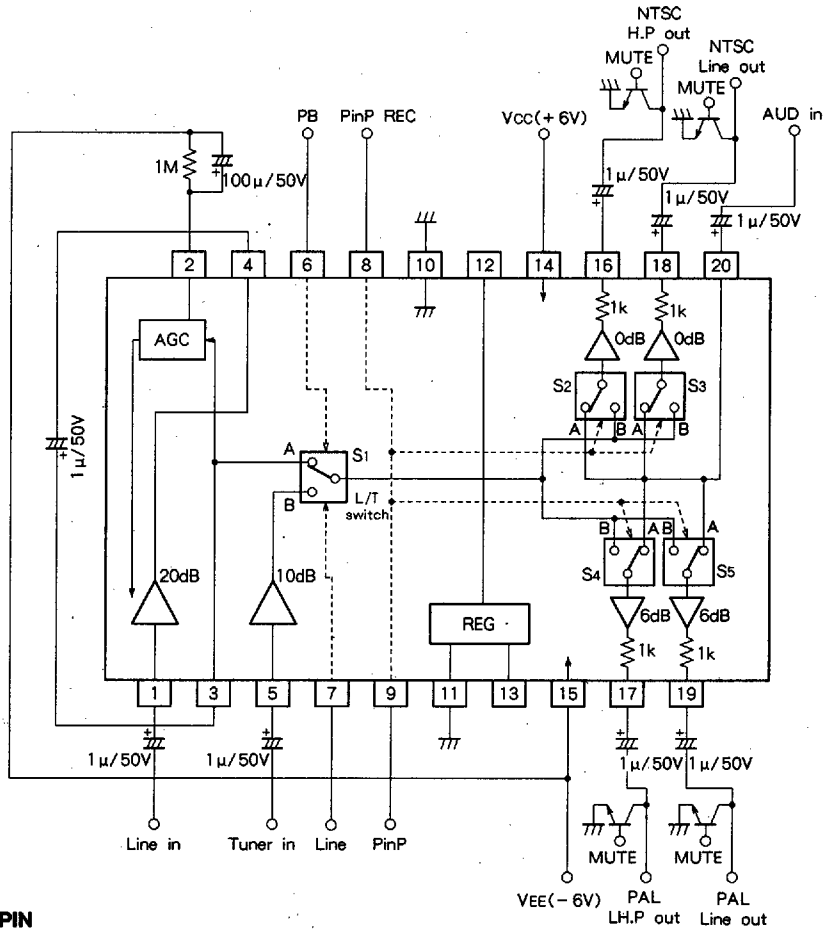

DESCRIPTION OF PIN

Pin No.	Name	Description
①	Line in	Line input pin
②	AGC detection	AGC rectified current voltage pin
③	AGC OUT in	AGC Amp output signal input pin
④	AGC OUT	AGC Amp output pin
⑤	Tuner in	Tuner input pin
⑥	PB	Logic input pin
⑦	Line	Logic input pin
⑧	PinP REV	Logic input pin
⑨	PinP	Logic input pin
⑩	Logic GND	Logic circuit grounding
⑪	Vref1	Reference 1 pin
⑫	Vref2	Reference 2 pin
⑬	Vref3	Reference 3 pin
⑭	+ Vcc	Power supply pin
⑮	GND	Analog signal system grounding
⑯	NTSC H. P out	NTSC headphone output pin
⑰	PAL H. P out	PAL headphone output pin
⑱	NTSC Line out	NTSC line output pin
⑲	PAL Line out	PAL line output pin
⑳	AUD in	Audio input pin

Units Resistance : Ω  
Capacitance : F