

RFW3M-PA Transceiver Module

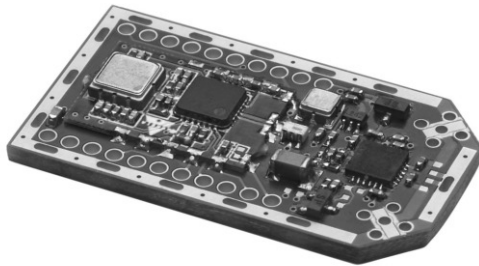

The company's products are covered by one or more of the following:

Taiwan Patent No. 155994, Taiwan Patent No. 176767, USA Patent No. 6,535,545. Other patents pending.

GENERAL DESCRIPTION

The RFW3M-PA is an extended-range, half duplex, wireless radio transceiver module. The module includes RFW3M transceiver, a power amplifier, and a low noise amplifier. Two antenna ports further enhance the range by allowing antenna diversity.

The transceiver operates in the world wide unlicensed Industrial Scientific and Medical (ISM) band of 2400 - 2483.5 MHz, complying with worldwide regulations and standards. The module supports 5 operating channels within this band. Each channel utilizes a unique Direct Sequence Spread Spectrum (DSSS) code. The modulation scheme is 100 % Amplitude Shift Keying (ASK).

KEY FEATURES

- Designed for extended range wireless communication in the 2.4 GHz - world wide license free ISM band
- High Data rate - up to 3 Mbps
- Frequency agility - supports 5 different operating channels
- Each channel utilizes DSSS, with a unique spreading code
- Typical peak output power of 21 dBm
- Typical sensitivity - 78 dBm
- Complies with FCC and ETSI regulations
- Short signal acquisition time 1.2 μ s
- RFW3M-PA is RoHS compliant
- Wide operating temperature range (- 40 °C) to (+ 85 °C)

TYPICAL APPLICATIONS

- Home automation and security
- Wireless high quality audio
- Wireless video
- Wireless sensors
- Wireless headsets
- Toys
- Wireless USB

Low power consumption is achieved due to the following characteristics:

In standby mode, the transceiver consumes almost no power (12 μ A). It features very short wakeup and lockup time and the signal acquisition requires only 1.2 μ s. Thus, the overhead has been almost eliminated, enabling the design of highly efficient power consumption schemes.

In addition to the control lines required by RFW3M, four digital lines control both the power amplifiers and low noise amplifier. These lines are used to switch between transmitting and receiving modes. Two more digital lines control antenna diversity. RFW3M-PA has a total of 21 interface pins.

RFW3M-PA can be fitted with an RF shield, for applications sensitive to EMI.

The module is designed to operate in a wide temperature range (- 40 °C) to (85 °C), making it suitable for industrial and consumer products.

RFW3M-PA

Vishay RFWaves



BLOCK DIAGRAM AND PIN OUT

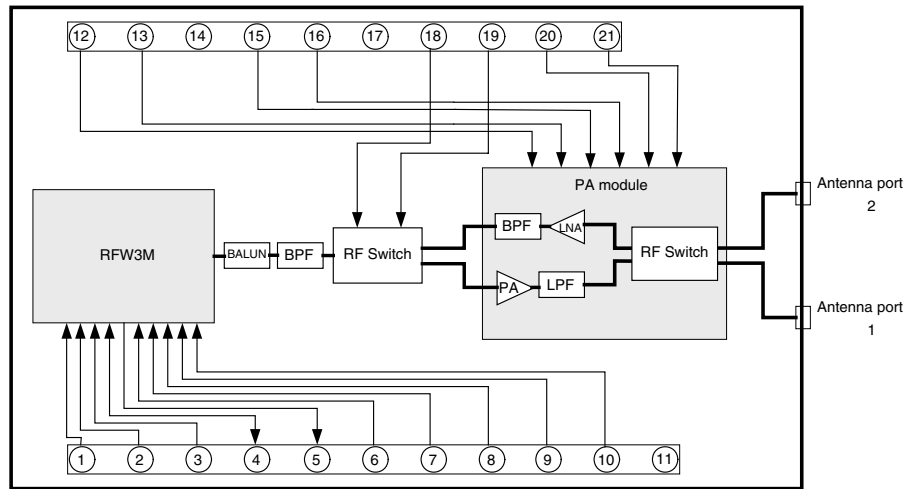

Figure 1. Block diagram

MECHANICAL DIMENSIONS

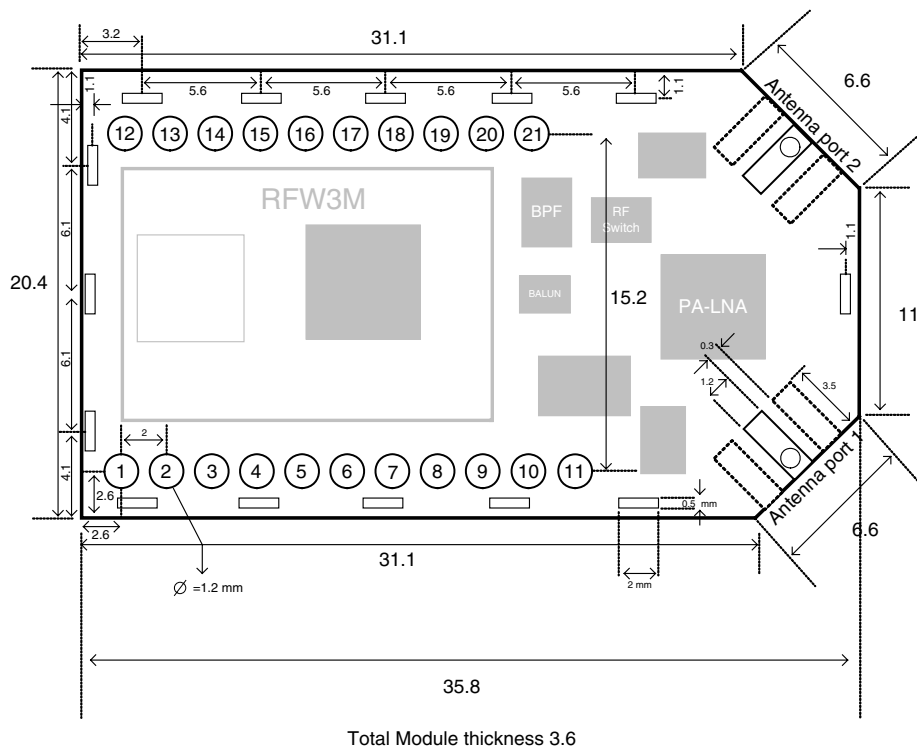

Figure 2. Mechanical dimensions in mm

RFW3M-PA has limited built-in ESD protection. The leads should be shorted together or the device placed in conductive foam during storage or handling to prevent electrostatic damage. Please note, leads are not provided with the RFW3M-PA.

The two antenna ports of RFW3M-PA are not ESD protected. Special care must be given while handling these ports.

Life Support Policy and Use in Safety-Critical Applications: Vishay RFWaves' products are not authorized for use in life-support or safety-critical applications.



Not for new design, this product will be obsoleted soon

RFW3M-PA
Vishay RFWaves

The following table describes the pin out of the RFW3M-PA Module.

PINOUT												
PIN #	Line Name	Type	Description									
1	RF - V _{CC}	Input-power	Feed regulated 3.3 ± 0.1 V into this pin. Peak current 50 mA. This pin feeds power only to the RFW3M transceiver									
2	GROUND	Input-power	Ground									
3	RF ACTIVATE ^(1, 2)	Input-digital	RF Activate control line. High = Active; Low = Standby									
4	DATA - IO ⁽¹⁾	Input/output-digital	Serial Data Input/Output									
5	RSSI ⁽¹⁾	Output-analog	Received Signal Strength Indication. Maximum allowed sink current 40 nA									
6	TXRX ^(1, 2)	Input-digital	Transmit (TX) receive (RX) control. High = Tx; Low = Rx									
7	SDATA ⁽¹⁾	Input-digital	Serial control data bus input. Apply control sequences into this pin to configure the module									
8	SCLCK ⁽¹⁾	Input-digital	Serial control data bus clock. Apply serial clock signal into this pin while configuring the module									
9	LOAD ⁽¹⁾	Input-digital	Serial control data bus enable									
10	OSCI ⁽¹⁾	Input-analog	External oscillator input. This pin serves as the reference frequency to the transceiver Synthesizer. Inject into this pin a signal as described below, via a DC Block capacitor: - Swing 500 - 750 V _{ptp} - Frequency 6, 12 or 24 MHz									
11	NOT CONNECTED		Leave opened									
12	LNA-CNTL ⁽²⁾	Input-digital	LNA control line. High = LNA turned off; Low = LNA turned on									
13	PA-CNTL ⁽²⁾	Input-digital	PA control line. High = PA turned off; Low = PA turned on									
14	NOT CONNECTED		Leave opened									
15	ANT-SELECT NOT ⁽²⁾	Input-digital	Logical NOT of Ant-Select control line during Tx and Rx modes. Low in Standby mode.									
16	ANT-SELECT ⁽²⁾	Input-digital	Antenna select control line <table border="1" style="margin-left: 20px;"> <thead> <tr> <th>ANT SELECT</th> <th>Tx mode (pin 13 high)</th> <th>Rx mode (pin 13 low)</th> </tr> </thead> <tbody> <tr> <td>High</td> <td>Ant Port 1</td> <td>Ant Port 2</td> </tr> <tr> <td>Low</td> <td>Ant Port 2</td> <td>Ant Port 1</td> </tr> </tbody> </table> Low in Standby mode	ANT SELECT	Tx mode (pin 13 high)	Rx mode (pin 13 low)	High	Ant Port 1	Ant Port 2	Low	Ant Port 2	Ant Port 1
ANT SELECT	Tx mode (pin 13 high)	Rx mode (pin 13 low)										
High	Ant Port 1	Ant Port 2										
Low	Ant Port 2	Ant Port 1										
17	NOT CONNECTED		Leave opened									
18	SWITCH-CNTL-NOT ⁽²⁾	Input-digital	Logical NOT of Switch-CNTL line during Tx and Rx modes. Low in Standby mode. High = Rx; Low = Tx; Low = Standby									
19	SWITCH-CNTL ⁽²⁾	Input-digital	RF switch control line. High=Tx; Low=Rx; Low = Standby									
20	GROUND	Input-power	Ground									
21	RF - V _{CC}	Input-power	Feed regulated 3.3 ± 0.1 V into this pin. Peak current 250 mA. This pin feeds power only to the PA/LNA component									

⁽¹⁾ See RFW3M datasheet for more details

⁽²⁾ See timing diagram for details



OPERATION MODES

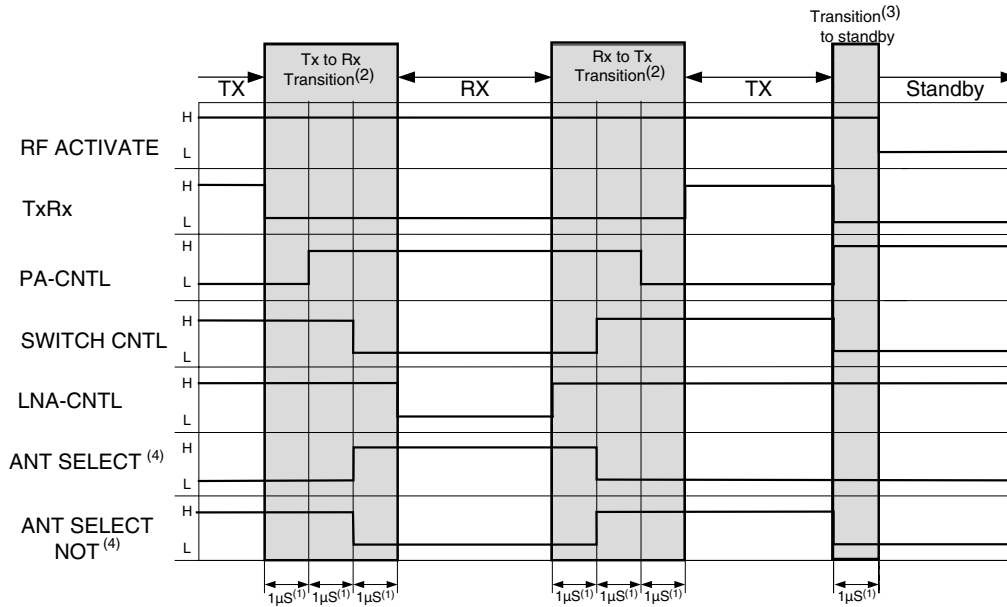

Figure 3. Timing Diagram

- (1) The 1 μs delays are minimum values. If desired, these delays can be increased.
- (2) During the transition time, the module is neither in TX or RX mode, therefore, no data can be sent or received during these times.
- (3) This diagram describes the transition from TX mode to stand-by-mode. The control line configuration in stand-by mode remains the same also when the transition takes place from RX mode to stand-by mode.
- (4) This diagram displays the control line configuration utilizing antenna port 2. If antenna port 1 is desired, the antenna control lines, in TX and RX, modes should be reversed.

TRUTH TABLE						
STATE	RF ACTIVATE ⁽¹⁾	TXRX ⁽¹⁾	PA-CNTL ⁽²⁾	LNA-CNTL ⁽²⁾	SWITCH CNTL ⁽²⁾	ANT-SELECT ⁽²⁾
Standby	L	L	H	H	L	L
TX antenna 1	H	H	L	H	H	H
TX antenna 2	H	H	L	H	H	L
RX antenna 1	H	L	H	L	L	L
RX antenna 2	H	L	H	L	L	H

(1) See RFW3M for details regarding High/Low voltage values
 (2) CMOS levels



CHARACTERISTICS	
Typical output power	21 dBm Peak
Typical receive sensitivity	- 78 dBm Peak
Typical total link budget	99 dB
Typical current consumption in transmit (Tx) mode	200 mA Peak
Typical current consumption in receive (Rx) mode	50 mA Peak
Typical standby current consumption	12 μ A
Antenna diversity	Antenna diversity helps overcome the harmful effect of multipath, which characterizes indoor environments
Antenna impedance	50 Ω unbalanced
Antenna mechanical interface	Antenna ports designed for MMCX connectors or direct soldering of coaxial cable. Cable and/or connector not provided
Main board interface	Two sets of 11 and 10 pins (21 pins total). 1.2 mm diameter, 2 mm pitch. Connector not provided
RF shield interface	14 pin footprint designed to accommodate an RF shield. RF shield not provided
Module dimensions	20.4 x 35.8 mm
Carrier PCB thickness	1.6 mm
Total module thickness	3.6 mm
Channel agility	To insure compliance with both FCC and ETSI regulations, it is recommended using only the central five of the available seven channels offered by RFW3M. Channels 1 and 7 should not be used

DESIGN CONSIDERATIONS

The RFW3M-PA carrier board has been designed especially to accommodate the RFW3M transceiver and the PA-LNA module. The layout has been carefully designed to prevent oscillation and RF leakage phenomena. Following the guidelines below will minimize the risk of introducing such harmful effects during the integration of RFW3M-PA into the application.

1. When connecting the antennas using a coaxial cable, make sure the cable has 50 Ω impedance with low loss at 2.44 Ghz (loss < 2 db/m). In addition, the soldering quality is critical for optimal power transmission. Also, make sure that the coaxial cable exposed length is lower than 3 mm.
2. The antennas should be placed at a distance of at least 3 cm from the module.
3. The antenna should be 50 Ω , unbalance at 2.44 Ghz.
4. It is recommended using a separate DC regulator for the RF3M-PA module. During transmission, the DC circuit is required to support short bursts of up to 300 mA, and tolerate no more than 200 mV drop in voltage. In receive mode, the DC circuit is required to support up to 50 mA. To prevent loss of sensitivity in receive mode, insure that the voltage ripple is less than 50 mV peak to peak.
5. When positioning the RFW3M-PA, make sure that maximum distance is kept between the module and high frequency noise sources such as oscillators, fast digital lines, DC to DC switched converters, etc.
6. In Standby mode, The DATA-IO line is undefined. For this reason, a 100 K Ω pull down resistor is recommended on this line.



Disclaimer

ALL PRODUCT, PRODUCT SPECIFICATIONS AND DATA ARE SUBJECT TO CHANGE WITHOUT NOTICE TO IMPROVE RELIABILITY, FUNCTION OR DESIGN OR OTHERWISE.

Vishay Intertechnology, Inc., its affiliates, agents, and employees, and all persons acting on its or their behalf (collectively, "Vishay"), disclaim any and all liability for any errors, inaccuracies or incompleteness contained in any datasheet or in any other disclosure relating to any product.

Vishay makes no warranty, representation or guarantee regarding the suitability of the products for any particular purpose or the continuing production of any product. To the maximum extent permitted by applicable law, Vishay disclaims (i) any and all liability arising out of the application or use of any product, (ii) any and all liability, including without limitation special, consequential or incidental damages, and (iii) any and all implied warranties, including warranties of fitness for particular purpose, non-infringement and merchantability.

Statements regarding the suitability of products for certain types of applications are based on Vishay's knowledge of typical requirements that are often placed on Vishay products in generic applications. Such statements are not binding statements about the suitability of products for a particular application. It is the customer's responsibility to validate that a particular product with the properties described in the product specification is suitable for use in a particular application. Parameters provided in datasheets and/or specifications may vary in different applications and performance may vary over time. All operating parameters, including typical parameters, must be validated for each customer application by the customer's technical experts. Product specifications do not expand or otherwise modify Vishay's terms and conditions of purchase, including but not limited to the warranty expressed therein.

Except as expressly indicated in writing, Vishay products are not designed for use in medical, life-saving, or life-sustaining applications or for any other application in which the failure of the Vishay product could result in personal injury or death. Customers using or selling Vishay products not expressly indicated for use in such applications do so at their own risk. Please contact authorized Vishay personnel to obtain written terms and conditions regarding products designed for such applications.

No license, express or implied, by estoppel or otherwise, to any intellectual property rights is granted by this document or by any conduct of Vishay. Product names and markings noted herein may be trademarks of their respective owners.

Material Category Policy

Vishay Intertechnology, Inc. hereby certifies that all its products that are identified as RoHS-Compliant fulfill the definitions and restrictions defined under Directive 2011/65/EU of The European Parliament and of the Council of June 8, 2011 on the restriction of the use of certain hazardous substances in electrical and electronic equipment (EEE) - recast, unless otherwise specified as non-compliant.

Please note that some Vishay documentation may still make reference to RoHS Directive 2002/95/EC. We confirm that all the products identified as being compliant to Directive 2002/95/EC conform to Directive 2011/65/EU.

Vishay Intertechnology, Inc. hereby certifies that all its products that are identified as Halogen-Free follow Halogen-Free requirements as per JEDEC JS709A standards. Please note that some Vishay documentation may still make reference to the IEC 61249-2-21 definition. We confirm that all the products identified as being compliant to IEC 61249-2-21 conform to JEDEC JS709A standards.