

Device connector, front mounting - ST-17S1N8AAD00S - 1607652

Please be informed that the data shown in this PDF Document is generated from our Online Catalog. Please find the complete data in the user's documentation. Our General Terms of Use for Downloads are valid (<http://phoenixcontact.com/download>)



Device connector, front mounting, angled rotatable, SPEEDCON locking, M17, number of positions: 17, type of contact: Socket, Axial O-ring, 4x Ø2,7, shielded: yes, flange dimensions: 21.6 mm x 21.6 mm, degree of protection: IP67, number of positions: 17, connection method: Crimp connection



Key Commercial Data

Packing unit	16 pc
GTIN	
GTIN	4046356273602

Technical data

Environmental Product Compliance

China RoHS	Environmentally Friendly Use Period = 50 years
	For details about hazardous substances go to tab "Downloads", Category "Manufacturer's declaration"

Drawings

Schematic diagram

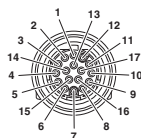

Connector pin assignment

Dimensional drawing

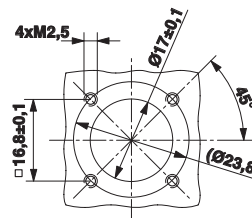

Device connector, front mounting - ST-17S1N8AAD00S - 1607652

Diagram

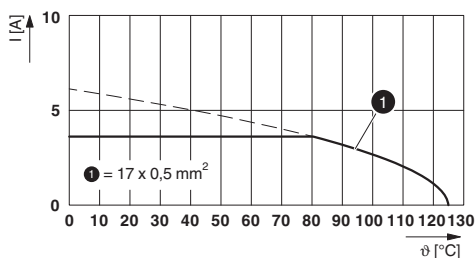

I = current strength, ϑ = ambient temperature, 17x 3.6 A

Dimensional drawing

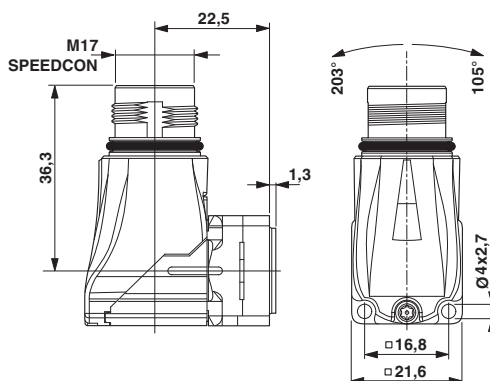

Classifications

eCl@ss

eCl@ss 10.0.1	27440109
eCl@ss 4.0	27260700
eCl@ss 4.1	27260700
eCl@ss 5.0	27260700
eCl@ss 5.1	27260700
eCl@ss 6.0	27260700
eCl@ss 7.0	27440102
eCl@ss 9.0	27440103

ETIM

ETIM 3.0	EC001121
ETIM 4.0	EC001121
ETIM 6.0	EC002061

UNSPSC

UNSPSC 6.01	43172015
UNSPSC 7.0901	43201404

Device connector, front mounting - ST-17S1N8AAD00S - 1607652

Classifications

UNSPSC

UNSPSC 11	43172015
UNSPSC 12.01	43201404
UNSPSC 13.2	39121413
UNSPSC 18.0	39121413
UNSPSC 19.0	39121413
UNSPSC 20.0	39121413
UNSPSC 21.0	39121413

Approvals

Approvals

Approvals

UL Recognized / cUL Recognized / EAC / cULus Recognized

Ex Approvals

Approval details

UL Recognized		http://database.ul.com/cgi-bin/XYV/template/LISEXT/1FRAME/index.htm	FILE E 335019
Nominal voltage UN	48 V		
Nominal current IN	1 A		
mm ² /AWG/kcmil	26		

cUL Recognized		http://database.ul.com/cgi-bin/XYV/template/LISEXT/1FRAME/index.htm	FILE E 335019
Nominal voltage UN	48 V		
Nominal current IN	1 A		
mm ² /AWG/kcmil	26		

EAC		B.01687
-----	---	---------

Device connector, front mounting - ST-17S1N8AAD00S - 1607652

Approvals

cULus Recognized



Accessories

Accessories

Mounting material

Contact removal tool - ST-Z0001 - 1607770



Unlocking tool for contact carriers for snapping in the M17 device connectors

Phoenix Contact 2021 © - all rights reserved
<http://www.phoenixcontact.com>

PHOENIX CONTACT GmbH & Co. KG
Flachsmarktstr. 8
32825 Blomberg
Germany
Tel. +49 5235 300
Fax +49 5235 3 41200
<http://www.phoenixcontact.com>