

THIS DRAWING IS UNPUBLISHED. RELEASED FOR PUBLICATION
 © COPYRIGHT - By - ALL RIGHTS RESERVED.

REVISIONS				
P	LTR	DESCRIPTION	DATE	APVD
	F	ECR-19-011878	19MAR2020	EZ WH

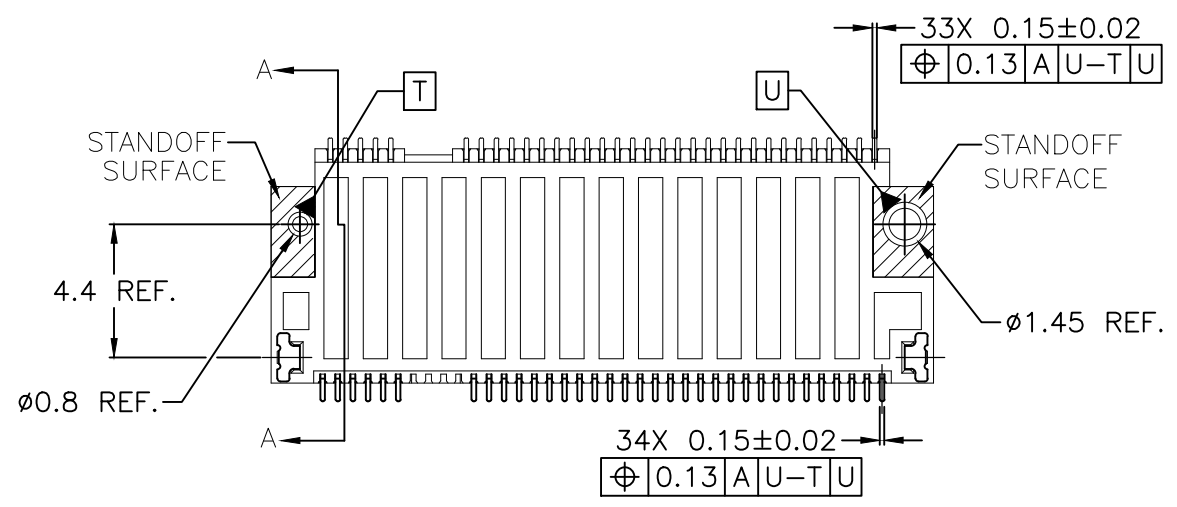
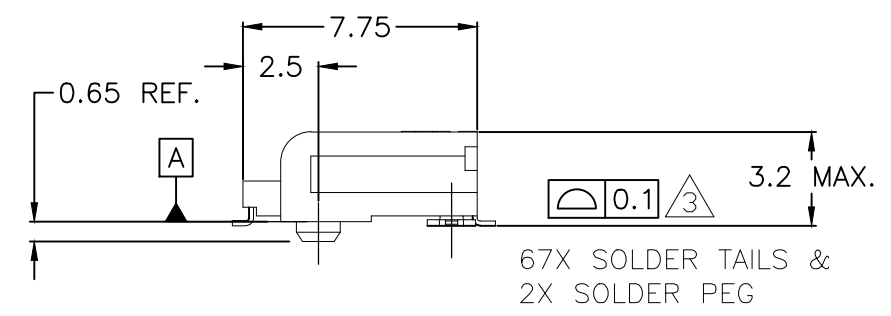
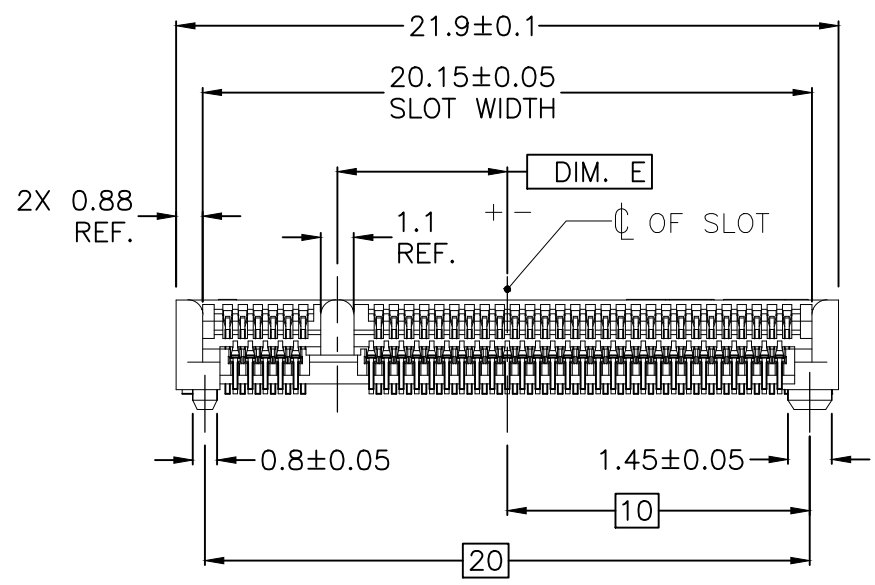
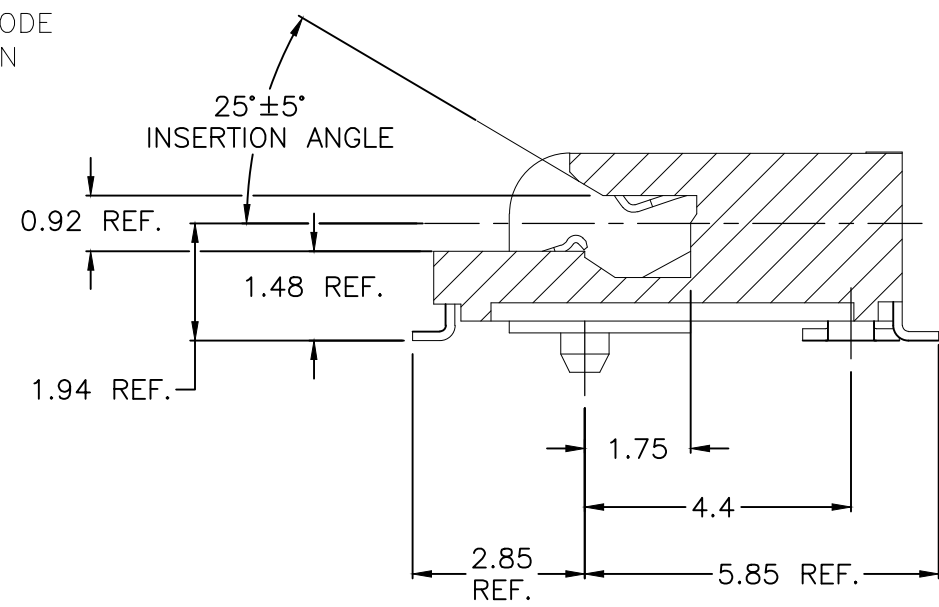
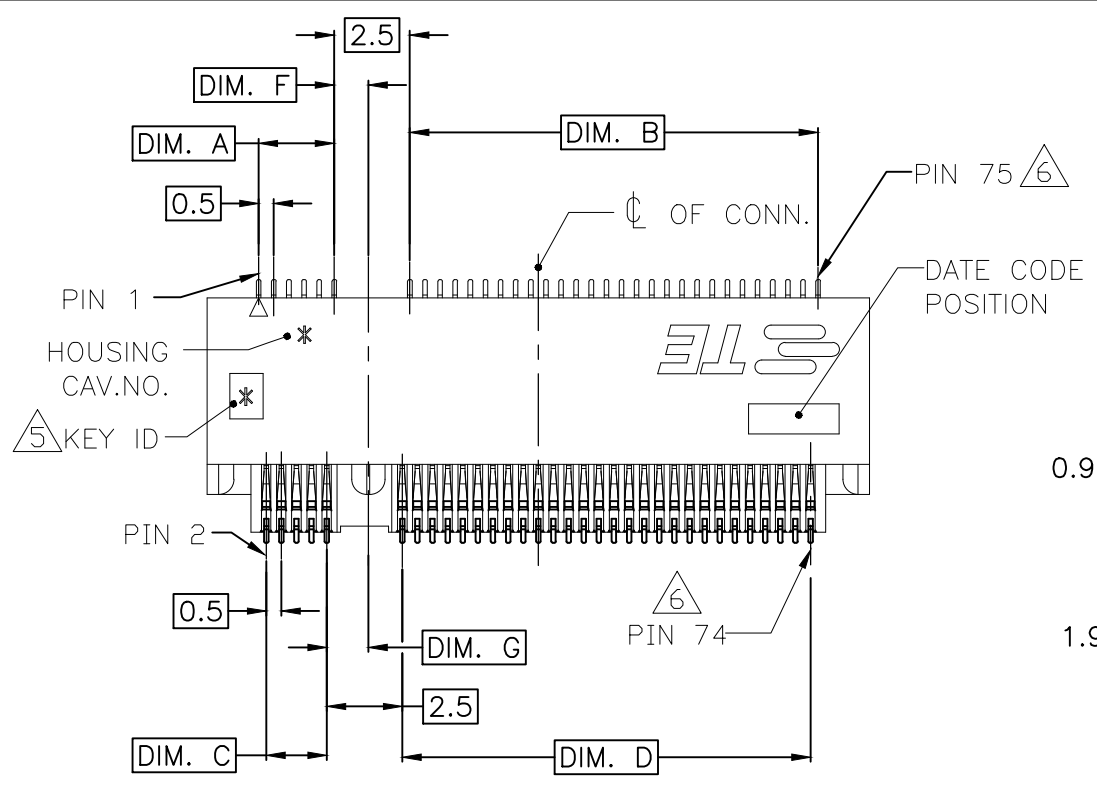

- NOTES:
- MATERIAL:
 - HOUSING : HIGH TEMPERATURE THERMOPLASTIC UL94V-0, COLOR: BLACK.
 - CONTACT: COPPER ALLOY.
 - SOLDER PEG: STAINLESS STEEL.
 - FINISH:
 - CONTACT: UNDERCOAT NICKEL 50u" min. ALL OVER; MATING AREA: GOLD PLATING, THE THICKNESS SEE TABLE LIST; SOLDERABLE AREA: GOLDFLASH.
 - SOLDER PEG: UNDERCOAT: NICKEL 50u" min. ALL OVER SOLDERABLE AREA: MATTE TIN 100u" min.
 - COPLANARITY: 0.10mm MAX.(BEFORE SOLDERING).
 - ACCEPTED MODULE BASED ON INDUSTRY STD.
 - KEY ID, "*" IS A CAPITAL LETTER PER THE PART NO.
 - THE PIN NO. DEFINITIONS ARE ACCORDING TO PCB FOOTPRINT, THE ACTUAL PIN QUANTITY IS ONLY 67 POS. FOR KEY TAKING OUT 8 POS.
 - THE PRODUCT IS RoHS COMPLIANT, BR 900PPM MAX., CL 900PPM MAX. BR+CL 1500 PPM MAX.
 - MINUS MEANS Ø OF KEY IS ON THE RIGHT SIDE OF CONN. Ø IN PAGE 1.

THIS DRAWING IS A CONTROLLED DOCUMENT.		DWN SIMON WU 90CT2012	TE Connectivity		
DIMENSIONS: mm		CHK SIMON LI 90CT2012			
TOLERANCES UNLESS OTHERWISE SPECIFIED:		APVD COREL WANG 90CT2012	NAME		
0 PLC ± 0.30 1 PLC ± 0.30 2 PLC ± 0.20 3 PLC ± 0.10 4 PLC ANGLES ± - ± 3°		PRODUCT SPEC	M.2(NGFF)MINI CARD MOUNTING TYPE		
MATERIAL		APPLICATION SPEC	0.50mm PITCH 67 POS 3.2mm H		
FINISH		114-115006	DOUBLE SIDED MODULE		
		WEIGHT 0.51 G	SIZE A3	CAGE CODE 00779	DRAWING NO C-2199119
		CUSTOMER DRAWING	RESTRICTED TO	SCALE 4:1	SHEET 1 OF 5
				REV F	

THIS DRAWING IS UNPUBLISHED.

RELEASED FOR PUBLICATION

- . - .

REVISIONS

ALL RIGHTS RESERVED.

© COPYRIGHT - By -

P	LTR	DESCRIPTION	DATE	DWN	APVD
-	-	SEE SHEET 1	-	-	-

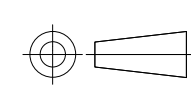

KEY ID.	PRODUCT SPEC.	GOLD SPEC.	DIM. G	DIM. F	DIM. E	DIM. D	DIM. C	DIM. B	DIM. A	PART NO.
M	108-115042	30u" MIN.	1.125	1.375	-6.125	1.5	14.0	2.0	14.0	1-2199119-6
		15u" MIN.								1-2199119-5
		10u" MIN.								1-2199119-4
	108-115049	GOLD FLASH								1-2199119-3
A	108-115042	10u" MIN.			6.625	14.5	1.0	14.5	1.5	1-2199119-2
E					2.625	10.5	5.0	10.5	5.5	1-2199119-1
B					5.625	13.5	2.0	13.5	2.5	1-2199119-0
A	108-115042	30u" MIN.	1.375	1.125	6.625	14.5	1.0	14.5	1.5	2199119-9
		15u" MIN.								2199119-8
		108-115049								GOLD FLASH
E	108-115042	30u" MIN.			2.625	10.5	5.0	10.5	5.5	2199119-6
B					5.625	13.5	2.0	13.5	2.5	2199119-5
E					2.625	10.5	5.0	10.5	5.5	2199119-4
B	108-115042	15u" MIN.			5.625	13.5	2.0	13.5	2.5	2199119-3
E					2.625	10.5	5.0	10.5	5.5	2199119-2
B					108-115049	GOLD FLASH	5.625	13.5	2.0	13.5
										2199119-1

THIS DRAWING IS A CONTROLLED DOCUMENT.		DWN SIMON WU 90CT2012	 TE Connectivity			
		CHK SIMON LI 90CT2012				
DIMENSIONS: mm 		APVD COREL WANG 90CT2012	NAME M.2(NGFF)MINI CARD MOUNTING TYPE 0.50mm PITCH 67 POS 3.2mm H DOUBLE SIDED MODULE			
TOLERANCES UNLESS OTHERWISE SPECIFIED: 0 PLC ± 0.30 1 PLC ± 0.30 2 PLC ± 0.20 3 PLC ± 0.10 4 PLC ± - ANGLES ± 3°		PRODUCT SPEC	RESTRICTED TO			
MATERIAL		FINISH	APPLICATION SPEC	SIZE A3	CAGE CODE 00779	DRAWING NO C-2199119
			WEIGHT 0	SCALE 4:1 SHEET 2 of 5 REV F		
CUSTOMER DRAWING						

THIS DRAWING IS UNPUBLISHED. RELEASED FOR PUBLICATION
 © COPYRIGHT - By - ALL RIGHTS RESERVED.

REVISIONS				
P	LTR	DESCRIPTION	DATE	APVD
-	-	SEE SHEET 1	-	-

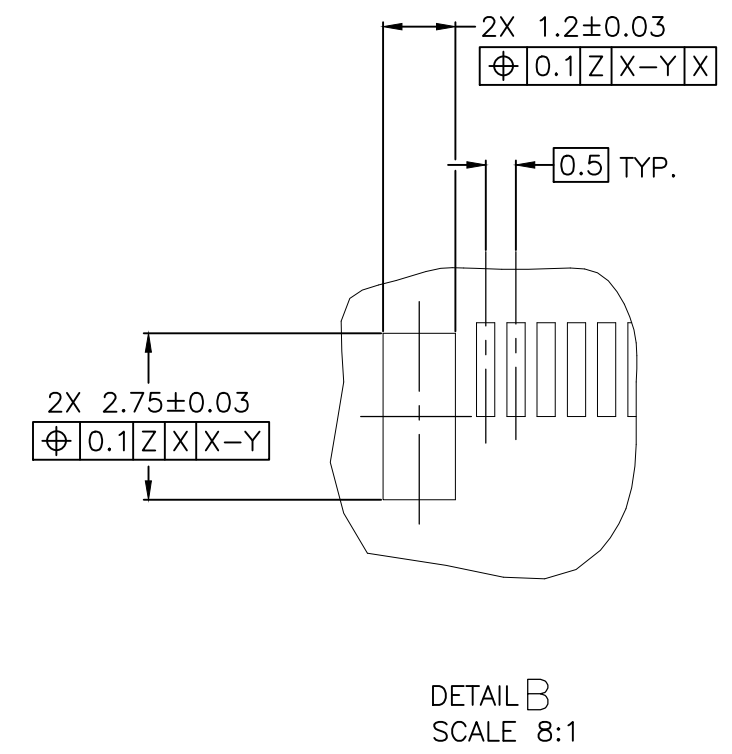
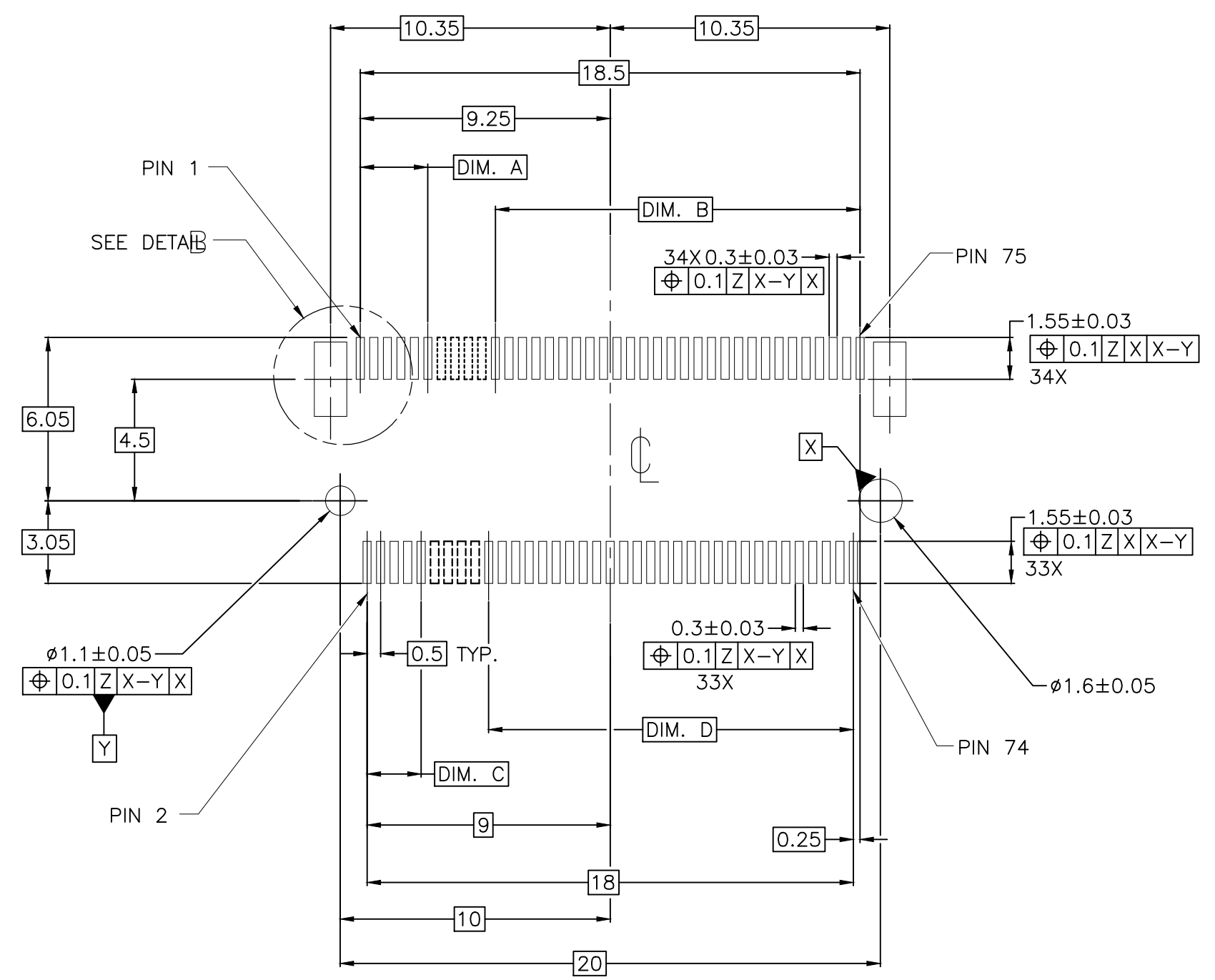

RECOMMENDED NGFF MINI CARD MOUNTING TYPE_SMT_PCB OUTLINE
 DATUM Z: PCB SOLDER SURFACE

M	1.5	14.0	2.0	14.0
E	10.5	5.0	10.5	5.5
B	13.5	2.0	13.5	2.5
A	14.5	1.0	14.5	1.5
KEY ID.	DIM. D	DIM. C	DIM. B	DIM. A

THIS DRAWING IS A CONTROLLED DOCUMENT.		DWN SIMON WU 90CT2012	 TE Connectivity	
DIMENSIONS: mm		CHK SIMON LI 90CT2012		
TOLERANCES UNLESS OTHERWISE SPECIFIED:		APVD COREL WANG 90CT2012	NAME M.2(NGFF)MINI CARD MOUNTING TYPE 0.50mm PITCH 67 POS 3.2mm H DOUBLE SIDED MODULE	
0 PLC ± 0.30 1 PLC ± 0.30 2 PLC ± 0.20 3 PLC ± 0.10 4 PLC ± - ANGLES ± 3°		PRODUCT SPEC	SIZE A3	
MATERIAL		APPLICATION SPEC	CAGE CODE 00779	DRAWING NO C-2199119
FINISH		WEIGHT	RESTRICTED TO	
		CUSTOMER DRAWING		SCALE 5:1
		SHEET 3 OF 5		REV F

THIS DRAWING IS UNPUBLISHED. RELEASED FOR PUBLICATION
 © COPYRIGHT - By - ALL RIGHTS RESERVED.

REVISIONS					
P	LTR	DESCRIPTION	DATE	DWN	APVD
-	-	SEE SHEET 1	-	-	-

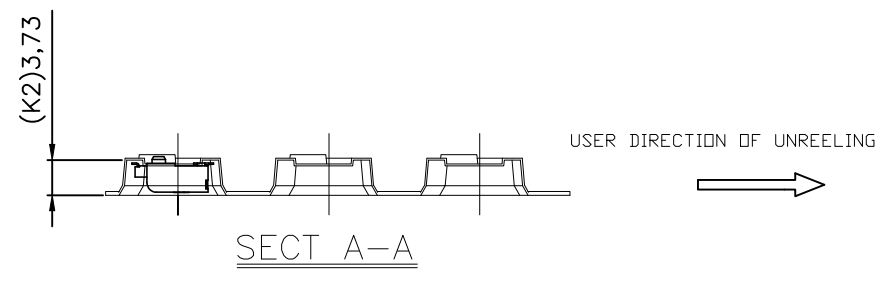
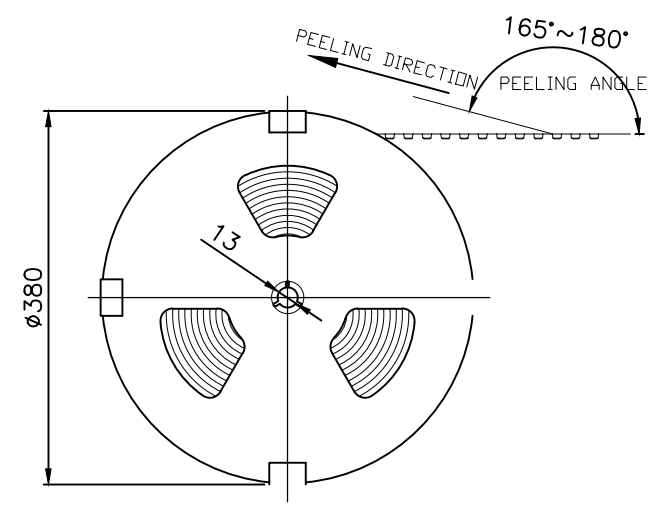

NOTES: (APPLIED TO CURRENT SHEET)

1. THE DIRECTION OF EACH CONNECTOR ON A EMBOSS IS REFERRED TO THIS DRAWING.
2. GENERAL TOLERANCE: ± 0.5 , $\pm 3^\circ$
3. PACKAGED IN EMBOSS TAPE AND PLASTIC RELL 1200PCS PER REEL.

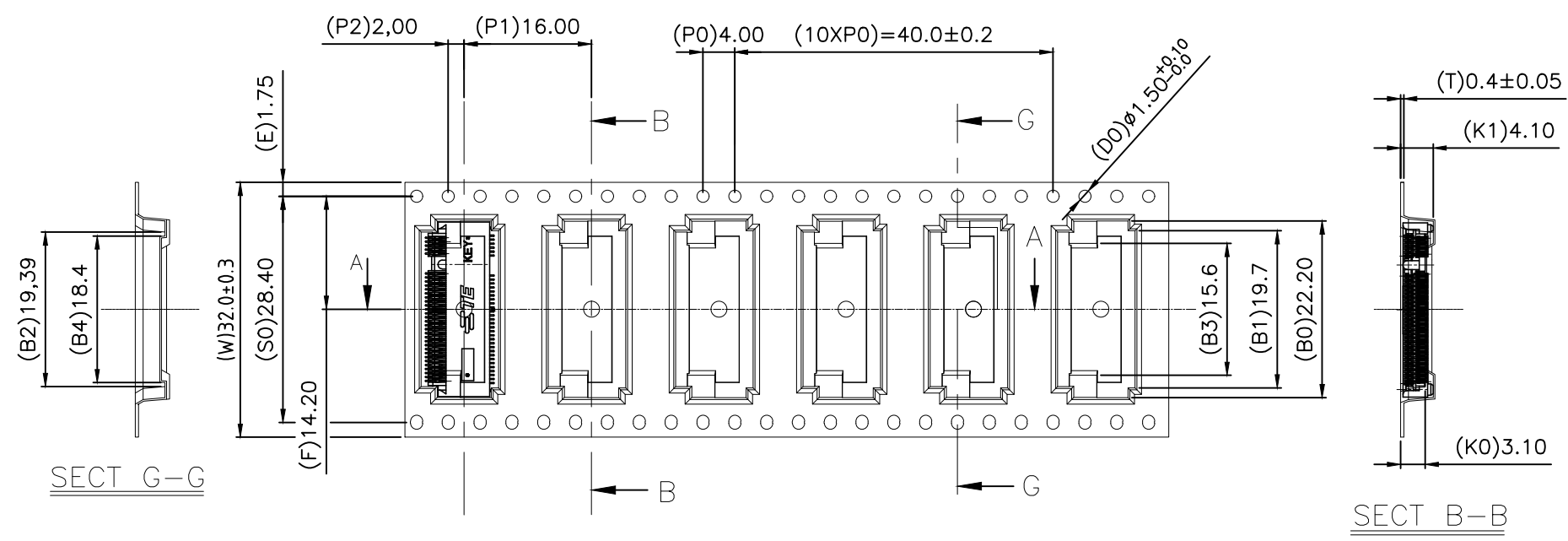

USER DIRECTION OF UNREELING

M	1-2199119-6
	1-2199119-5
	1-2199119-4
	1-2199119-3
A	1-2199119-2
E	1-2199119-1
B	1-2199119-0
A	2199119-9
	2199119-8
	2199119-7
E	2199119-6
B	2199119-5
E	2199119-4
B	2199119-3
E	2199119-2
B	2199119-1
KEY ID.	PART NO.

THIS DRAWING IS A CONTROLLED DOCUMENT.		DWN SIMON WU 90CT2012	TE Connectivity														
DIMENSIONS: mm		CHK SIMON LI 90CT2012															
TOLERANCES UNLESS OTHERWISE SPECIFIED:		APVD COREL WANG 90CT2012	NAME M.2(NGFF)MINI CARD MOUNTING TYPE 0.50mm PITCH 67 POS 3.2mm H DOUBLE SIDED MODULE														
<table border="1"> <tr><td>0 PLC</td><td>± 0.30</td></tr> <tr><td>1 PLC</td><td>± 0.30</td></tr> <tr><td>2 PLC</td><td>± 0.20</td></tr> <tr><td>3 PLC</td><td>± 0.10</td></tr> <tr><td>4 PLC</td><td>± -</td></tr> <tr><td>ANGLES</td><td>± 3°</td></tr> </table>		0 PLC	± 0.30	1 PLC	± 0.30	2 PLC	± 0.20	3 PLC	± 0.10	4 PLC	± -	ANGLES	± 3°	PRODUCT SPEC	SIZE A3		
0 PLC	± 0.30																
1 PLC	± 0.30																
2 PLC	± 0.20																
3 PLC	± 0.10																
4 PLC	± -																
ANGLES	± 3°																
MATERIAL		APPLICATION SPEC	CAGE CODE 00779	DRAWING NO C-2199119	RESTRICTED TO												
FINISH		WEIGHT	SCALE N/A														
		CUSTOMER DRAWING			SHEET 4 of 5												
					REV F												

THIS DRAWING IS UNPUBLISHED. RELEASED FOR PUBLICATION
 © COPYRIGHT - By - ALL RIGHTS RESERVED.

REVISIONS					
P	LTR	DESCRIPTION	DATE	DWN	APVD
-	-	SEE SHEET 1	-	-	-

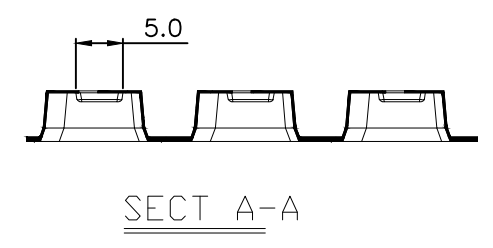
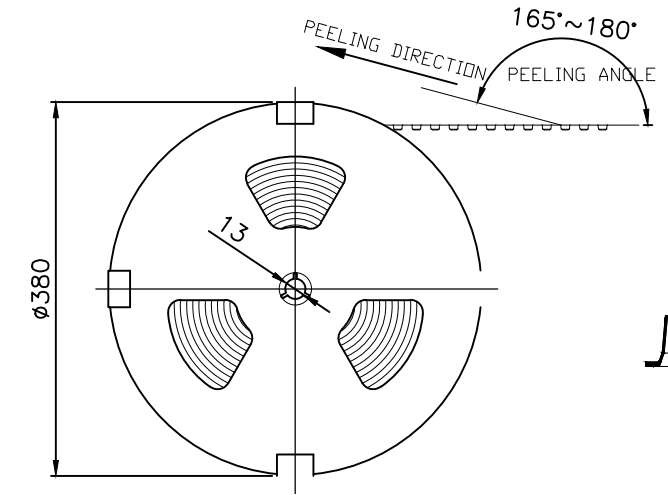

USER DIRECTION OF UNREELING
 →

NOTES: (APPLIED TO CURRENT SHEET)

1. THE DIRECTION OF EACH CONNECTOR ON A EMBOSS IS REFERRED TO THIS DRAWING.
2. GENERAL TOLERANCE: ±0.5, ±3°
3. PACKAGED IN EMBOSS TAPE AND PLASTIC RELL 1200PCS PER REEL.

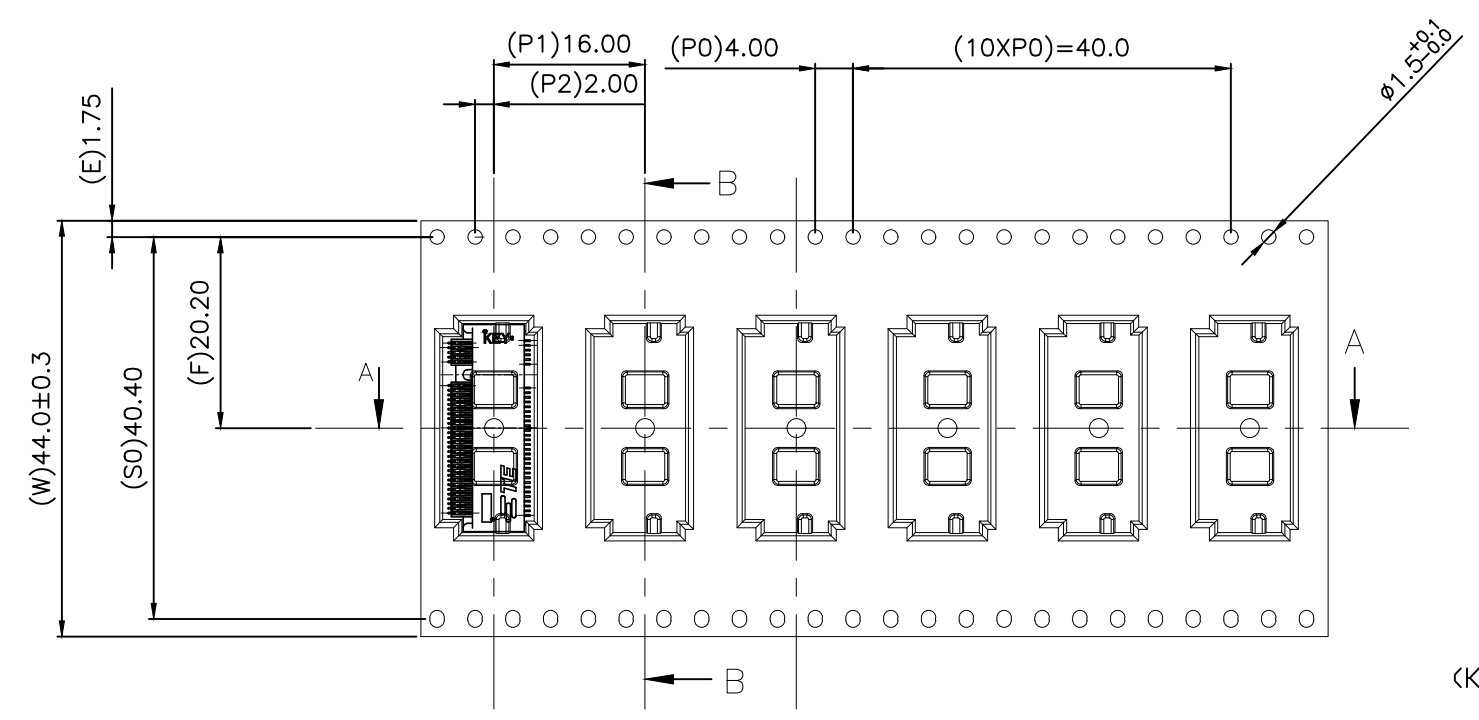

USER DIRECTION OF UNREELING
 →

SECT B-B
 N.I.S

B	3-2199119-1
KEY ID.	PART NO.

THIS DRAWING IS A CONTROLLED DOCUMENT.		DWN SIMON WU 90CT2012	TE Connectivity NAME M.2(NGFF)MINI CARD MOUNTING TYPE 0.50mm PITCH 67 POS 3.2mm H DOUBLE SIDED MODULE					
DIMENSIONS: mm		CHK SIMON LI 90CT2012				SIZE	CAGE CODE	DRAWING NO
TOLERANCES UNLESS OTHERWISE SPECIFIED:		APVD COREL WANG 90CT2012				A3	00779	C-2199119
0 PLC ± 0.30 1 PLC ± 0.30 2 PLC ± 0.20 3 PLC ± 0.10 4 PLC ± - ANGLES ± 3°		PRODUCT SPEC				RESTRICTED TO -		
MATERIAL -		FINISH -	CUSTOMER DRAWING					
			SCALE	SHEET	REV			
			N/A	5 OF 5	F			