

GaAs MMIC DBS 4 × 2 IF SWITCH MATRIX
DESCRIPTION

The μ PG188GR is intended for use in Direct Broadcast Satellite (DBS) applications within the Low Noise Block (LNB) down-converter for systems where at least multi LNB are required.

FEATURES

- High isolation : ISL = 30 dB TYP. (D/U-ratio)
- Control voltage : $V_{cont} = 0\text{ V}/+5\text{ V}$
- Insertion loss : $L_{INS} = 8\text{ dB TYP. } (Z_0 = 50\ \Omega)$
- 16-pin plastic HTSSOP package

ORDERING INFORMATION

Part Number	Package	Supplying Form
μ PG188GR-E1	16-pin plastic HTSSOP	<ul style="list-style-type: none"> • Embossed tape 12 mm wide • Qty 3 kpcs/reel

Remark To order evaluation samples, contact your nearby sales office.

Part number for sample order: μ PG188GR

Caution Observe precautions when handling because these devices are sensitive to electrostatic discharge.

The information in this document is subject to change without notice. Before using this document, please confirm that this is the latest version.
 Not all devices/types available in every country. Please check with local NEC Compound Semiconductor Devices representative for availability and additional information.

ABSOLUTE MAXIMUM RATINGS (T_A = +25°C, unless otherwise specified)

Parameter	Symbol	Ratings	Unit
Control Voltage 1 to 8	V _{cont1 to 8}	-1.0 to +6.0	V
Total Power Dissipation	P _{tot}	2 ^{Note}	W
Input Power	P _{in}	+10	dBm
Operating Ambient Temperature	T _A	-40 to +85	°C
Storage Temperature	T _{stg}	-65 to +150	°C

Note Mounted on double-sided copper-clad 50 × 50 × 1.6 mm epoxy glass PWB, T_A = +85°C

RECOMMENDED OPERATING RANGE (T_A = +25°C)

Parameter	Symbol	MIN.	TYP.	MAX.	Unit
Control Voltage (High)	V _{cont(H)}	+4.5	+5.0	+5.5	V
Control Voltage (Low)	V _{cont(L)}	-0.5	0	+0.5	V

ELECTRICAL CHARACTERISTICS

(T_A = +25°C, V_{cont} = 0 V/+5 V, P_{in} = 0 dBm, Z_o = 50 Ω, Each Port, unless otherwise specified)

Parameter	Symbol	Test Conditions	MIN.	TYP.	MAX.	Unit
Insertion Loss 1	L _{INS1}	f = 0.95 to 1.5 GHz	-	7.0	9.0	dB
Insertion Loss 2	L _{INS2}	f = 1.5 GHz to 2.15 GHz	-	8.0	10.0	dB
Insertion Loss Flatness	ΔL _{INS}	L _{INS} (0.95 GHz) - L _{INS} (2.15 GHz)	-	1.5	3.0	dB
Isolation D/U-ratio 1 ^{Note1}	ISL1	f = 0.95 to 1.5 GHz	29	32	-	dB
Isolation D/U-ratio 2 ^{Note1}	ISL2	f = 1.5 to 2.15 GHz	27	30	-	dB
Output Return Loss	RL _{OUT}	f = 0.95 to 2.15 GHz	10	15	-	dB
Control Current ^{Note2}	I _{cont}	V _{cont} = +5 V/0 V, RF OFF	-	-	0.5	mA

Notes 1. 'Isolation D/U-ratio' = |'signal leakage (off-state)' - 'insertion loss (on-state)'|

2. per 1 control pin

PIN CONNECTIONS AND INTERNAL BLOCK DIAGRAM

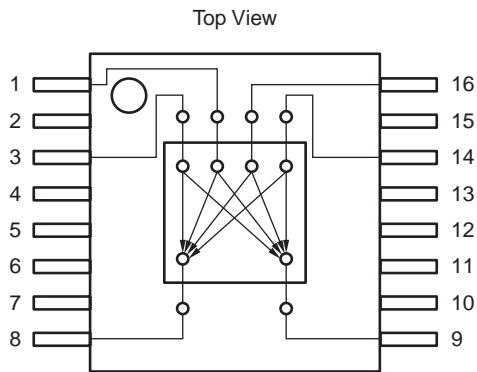

Pin No.	Pin Name	Pin No.	Pin Name
1	IN-C	9	OUT1
2	GND	10	V _{cont4}
3	IN-D	11	V _{cont3}
4	V _{cont5}	12	V _{cont2}
5	V _{cont6}	13	V _{cont1}
6	V _{cont7}	14	IN-A
7	V _{cont8}	15	GND
8	OUT2	16	IN-B

Remark Backside: GND

TRUTH TABLE

On Channel		Control Pin							
OUT1	OUT2	V _{cont1}	V _{cont2}	V _{cont3}	V _{cont4}	V _{cont5}	V _{cont6}	V _{cont7}	V _{cont8}
IN-A	–	High	Low	High	Low	–	–	–	–
IN-B	–	Low	High	High	Low	–	–	–	–
IN-C	–	High	Low	Low	High	–	–	–	–
IN-D	–	Low	High	Low	High	–	–	–	–
–	IN-A	–	–	–	–	Low	High	Low	High
–	IN-B	–	–	–	–	High	Low	Low	High
–	IN-C	–	–	–	–	Low	High	High	Low
–	IN-D	–	–	–	–	High	Low	High	Low

EVALUATION CIRCUIT (Reference Only)

V_{cont1} to V_{cont8} = 0 V/+5 V, P_{in} = 0 dBm, Z_o = 50 Ω , DC Blocking Capacitor = 56 pF

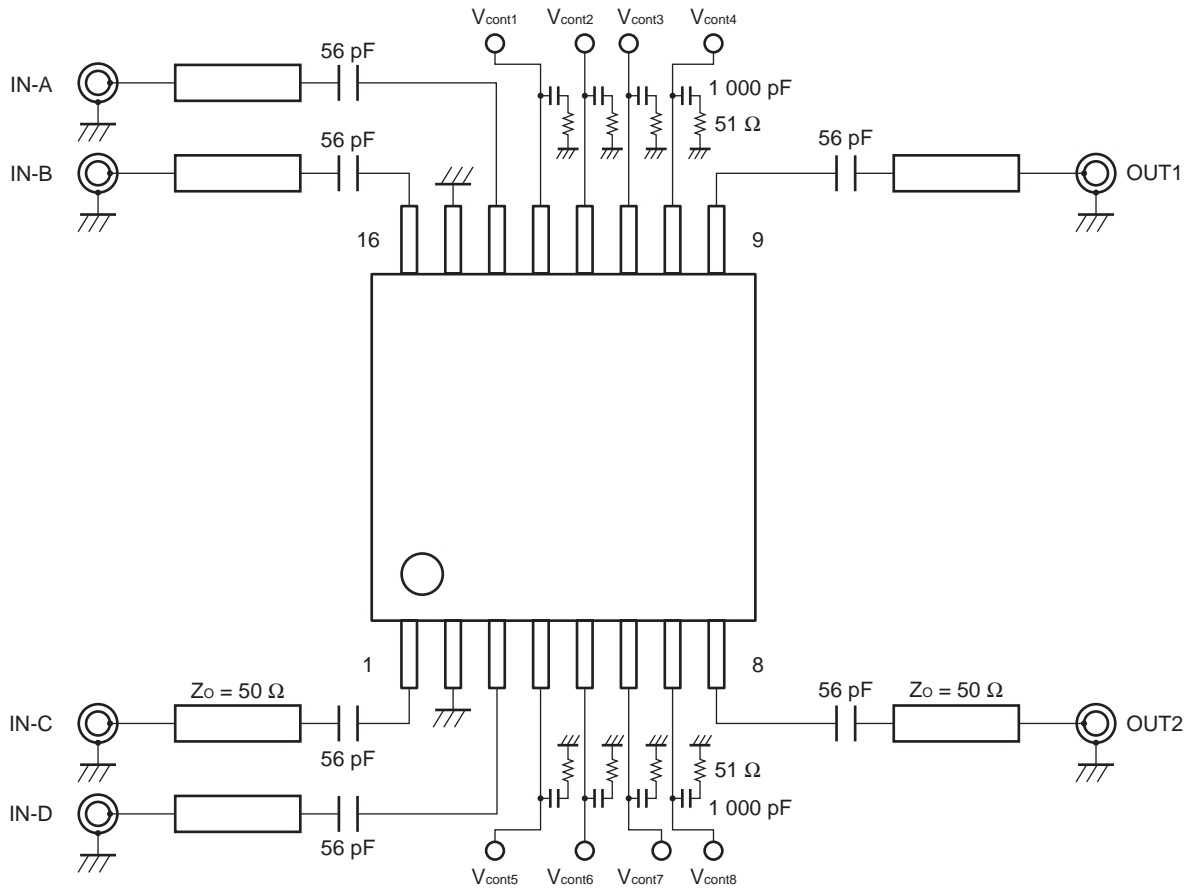

Caution For DC lines, chip capacitors and resistors are used to suppress unintended resonance.

TYPICAL CHARACTERISTICS

ON ROUTE

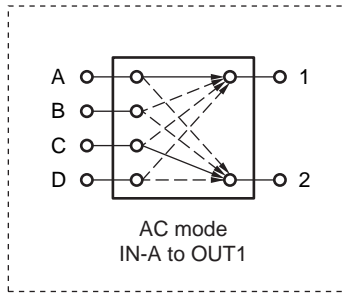

INPUT RETURN LOSS vs. FREQUENCY

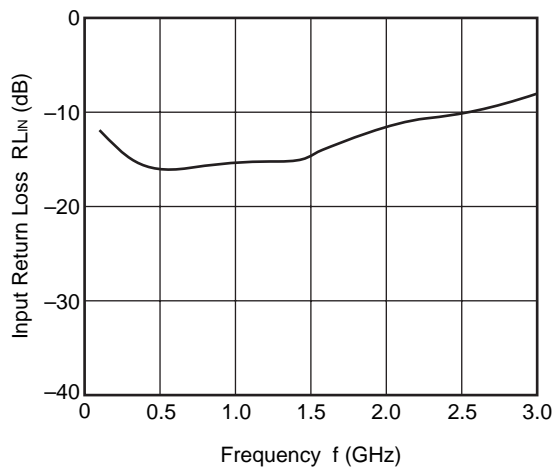

INSERTION LOSS vs. FREQUENCY

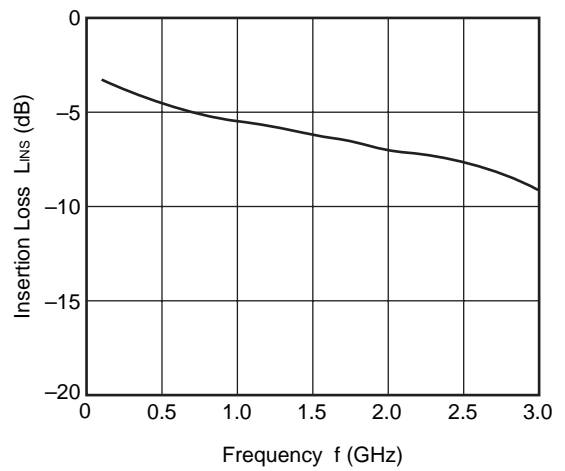

OUTPUT RETURN LOSS vs. FREQUENCY

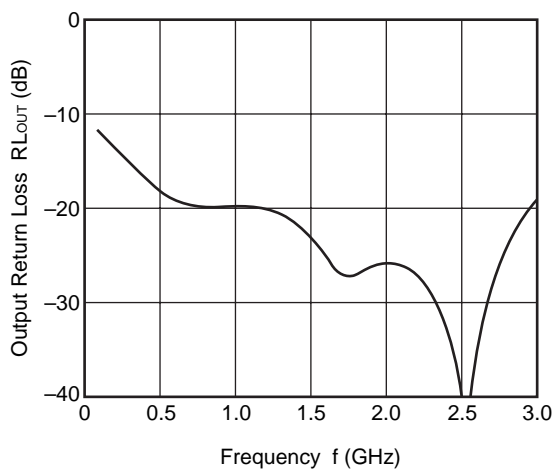

OFF ROUTE

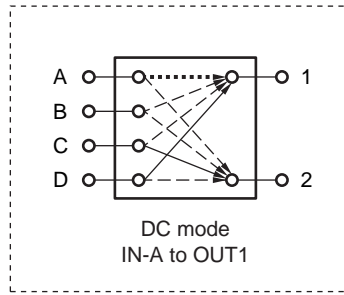

INPUT RETURN LOSS vs. FREQUENCY

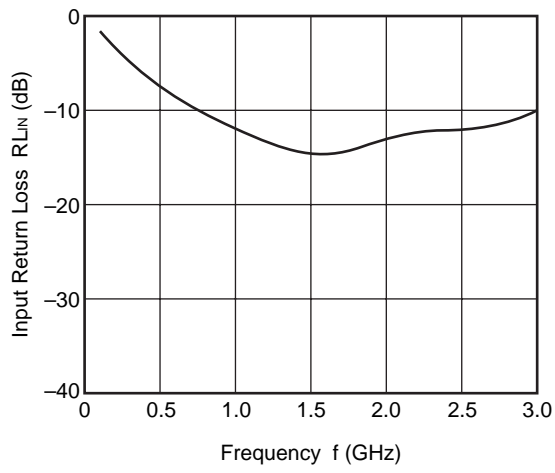

SIGNAL LEAKAGE vs. FREQUENCY

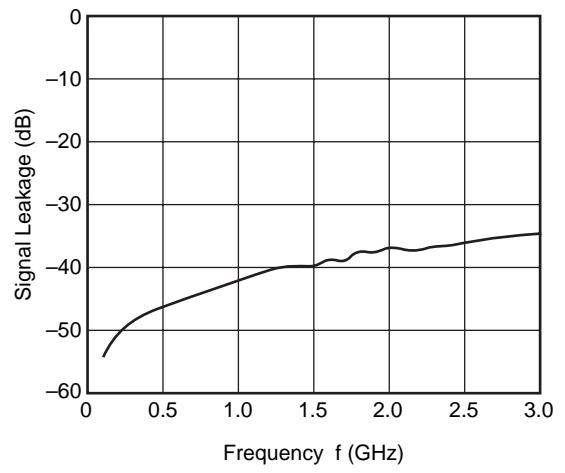

OUTPUT RETURN LOSS vs. FREQUENCY

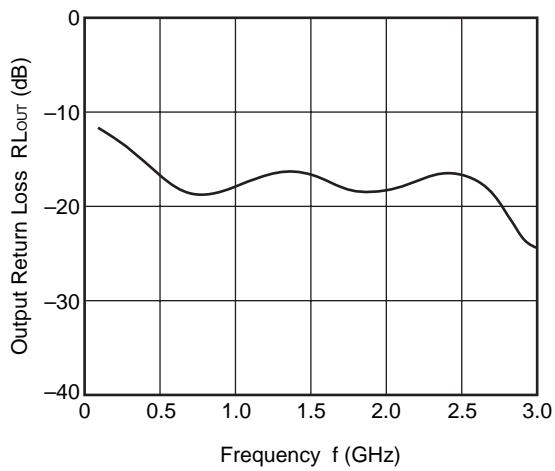

Remark The graphs indicate nominal characteristics.

PACKAGE DIMENSIONS

16-PIN PLASTIC HTSSOP (UNIT: mm)

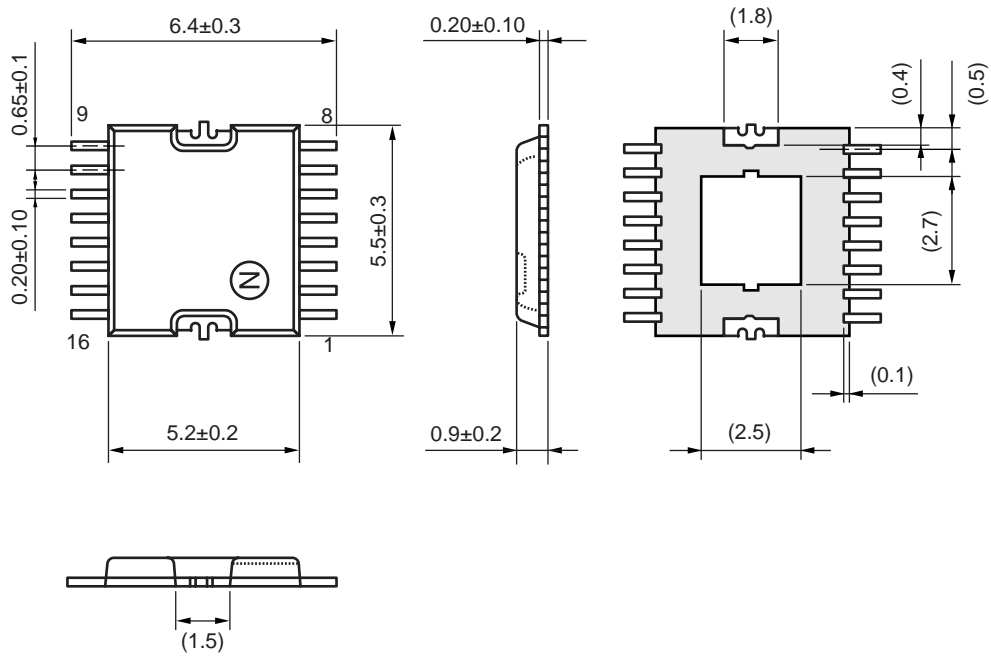

Remark (): Reference value

RECOMMENDED SOLDERING CONDITIONS

This product should be soldered and mounted under the following recommended conditions. For soldering methods and conditions other than those recommended below, contact your nearby sales office.

Soldering Method	Soldering Conditions	Condition Symbol
Infrared Reflow	Peak temperature (package surface temperature) : 260°C or below Time at peak temperature : 10 seconds or less Time at temperature of 220°C or higher : 60 seconds or less Preheating time at 120 to 180°C : 120±30 seconds Maximum number of reflow processes : 3 times Maximum chlorine content of rosin flux (% mass) : 0.2%(Wt.) or below	IR260
VPS	Peak temperature (package surface temperature) : 215°C or below Time at temperature of 200°C or higher : 25 to 40 seconds Preheating time at 120 to 150°C : 30 to 60 seconds Maximum number of reflow processes : 3 times Maximum chlorine content of rosin flux (% mass) : 0.2%(Wt.) or below	VP215
Wave Soldering	Peak temperature (molten solder temperature) : 260°C or below Time at peak temperature : 10 seconds or less Preheating temperature (package surface temperature) : 120°C or below Maximum number of flow processes : 1 time Maximum chlorine content of rosin flux (% mass) : 0.2%(Wt.) or below	WS260
Partial Heating	Peak temperature (pin temperature) : 350°C or below Soldering time (per side of device) : 3 seconds or less Maximum chlorine content of rosin flux (% mass) : 0.2%(Wt.) or below	HS350

Caution Do not use different soldering methods together (except for partial heating).

- **The information in this document is current as of August 2002. The information is subject to change without notice. For actual design-in, refer to the latest publications of NEC's data sheets or data books, etc., for the most up-to-date specifications of NEC semiconductor products. Not all products and/or types are available in every country. Please check with an NEC sales representative for availability and additional information.**
 - No part of this document may be copied or reproduced in any form or by any means without prior written consent of NEC. NEC assumes no responsibility for any errors that may appear in this document.
 - NEC does not assume any liability for infringement of patents, copyrights or other intellectual property rights of third parties by or arising from the use of NEC semiconductor products listed in this document or any other liability arising from the use of such products. No license, express, implied or otherwise, is granted under any patents, copyrights or other intellectual property rights of NEC or others.
 - Descriptions of circuits, software and other related information in this document are provided for illustrative purposes in semiconductor product operation and application examples. The incorporation of these circuits, software and information in the design of customer's equipment shall be done under the full responsibility of customer. NEC assumes no responsibility for any losses incurred by customers or third parties arising from the use of these circuits, software and information.
 - While NEC endeavours to enhance the quality, reliability and safety of NEC semiconductor products, customers agree and acknowledge that the possibility of defects thereof cannot be eliminated entirely. To minimize risks of damage to property or injury (including death) to persons arising from defects in NEC semiconductor products, customers must incorporate sufficient safety measures in their design, such as redundancy, fire-containment, and anti-failure features.
 - NEC semiconductor products are classified into the following three quality grades:
 "Standard", "Special" and "Specific". The "Specific" quality grade applies only to semiconductor products developed based on a customer-designated "quality assurance program" for a specific application. The recommended applications of a semiconductor product depend on its quality grade, as indicated below. Customers must check the quality grade of each semiconductor product before using it in a particular application.
 "Standard": Computers, office equipment, communications equipment, test and measurement equipment, audio and visual equipment, home electronic appliances, machine tools, personal electronic equipment and industrial robots
 "Special": Transportation equipment (automobiles, trains, ships, etc.), traffic control systems, anti-disaster systems, anti-crime systems, safety equipment and medical equipment (not specifically designed for life support)
 "Specific": Aircraft, aerospace equipment, submersible repeaters, nuclear reactor control systems, life support systems and medical equipment for life support, etc.
- The quality grade of NEC semiconductor products is "Standard" unless otherwise expressly specified in NEC's data sheets or data books, etc. If customers wish to use NEC semiconductor products in applications not intended by NEC, they must contact an NEC sales representative in advance to determine NEC's willingness to support a given application.
- (Note)
- (1) "NEC" as used in this statement means NEC Corporation, NEC Compound Semiconductor Devices, Ltd. and also includes its majority-owned subsidiaries.
 - (2) "NEC semiconductor products" means any semiconductor product developed or manufactured by or for NEC (as defined above).

M8E 00.4-0110

SAFETY INFORMATION ON THIS PRODUCT

<p>Caution</p>	<p>GaAs Products</p>	<p>The product contains gallium arsenide, GaAs. GaAs vapor and powder are hazardous to human health if inhaled or ingested.</p> <ul style="list-style-type: none"> • Do not destroy or burn the product. • Do not cut or cleave off any part of the product. • Do not crush or chemically dissolve the product. • Do not put the product in the mouth. <p>Follow related laws and ordinances for disposal. The product should be excluded from general industrial waste or household garbage.</p>
-----------------------	----------------------	-------------------------------------------------------------------------------------------------------------------------------------------------------------------------------------------------------------------------------------------------------------------------------------------------------------------------------------------------------------------------------------------------------------------------------------------------------------------------------------------------------------------------------------------------

► **Business issue**

NEC Compound Semiconductor Devices, Ltd.

5th Sales Group, Sales Division TEL: +81-3-3798-6372 FAX: +81-3-3798-6783 E-mail: salesinfo@csd-nec.com

NEC Compound Semiconductor Devices Hong Kong Limited

Hong Kong Head Office TEL: +852-3107-7303 FAX: +852-3107-7309
 Taipei Branch Office TEL: +886-2-8712-0478 FAX: +886-2-2545-3859
 Korea Branch Office TEL: +82-2-528-0301 FAX: +82-2-528-0302

NEC Electronics (Europe) GmbH <http://www.nec.de/>

TEL: +49-211-6503-01 FAX: +49-211-6503-487

California Eastern Laboratories, Inc. <http://www.cel.com/>

TEL: +1-408-988-3500 FAX: +1-408-988-0279

► **Technical issue**

NEC Compound Semiconductor Devices, Ltd. <http://www.csd-nec.com/>

Sales Engineering Group, Sales Division
 E-mail: techinfo@csd-nec.com FAX: +81-44-435-1918