MSC1201-xx

60-Bit VFD Tube Driver with Digital Dimming and PWM Conversion Function

GENERAL DESCRIPTION

The MSC1201-xx is a 1/2 duty vacuum fluorescent display tube driver implemented in Bi-CMOS technology. This LSI consists of 64-bit shift registers, 64 latches, PWM conversion circuit, a digital dimming circuit, 30-segment driver and 2-grid driver. As the MSC1201-xx has both a digital dimming circuit and a PWM conversion circuit which converts PWM signal for lamp dimming control to PWM signal for VFD tube dimming control, the dimming control can be realized without any external circuit.

The interface with a MCU can be done only with 3 wires (CS, DATA and CLOCK signals). Also, DATA and CLOCK signal lines can be shared with other peripherals because of chip select function by CS signal.

For the general purpose code, the code number is -01. (Product name: MSC1201-01GS-2K)

For a custom code, the code number will be ordered at any time.

FEATURES

- Single supply voltage : $V_{DD} = 8\text{ V to }18\text{ V}$ (built-in 5 V logic regulator)
- Operating temperature range : $T_a = -40^\circ\text{C to }+85^\circ\text{C}$
- 30-segment driver outputs ($I_{OH} = -6\text{ mA at }V_{OH} = V_{DD} - 0.8\text{ V}$)
- 2-grid pre-driver outputs ($I_{OH} = -30\text{ mA at }V_{OH} = V_{DD} - 0.8\text{ V}$)
- Built-in digital dimming circuit (11-bit resolution)
- Built-in oscillation circuit (external R and C, $f_{OSC} = 2.0\text{ MHz}$)
- Built-in Power-On-Reset circuit.
- Lamp PWM signal → Built-in PWM conversion circuit for vacuum fluorescent display tube.
- Built-in RC Oscillation (external R and C)
- Correspondence between shift register and output segment is settable optionally using built in mask programmable 30×30 PLA.
- Package :
44-pin plastic QFP (QFP44-P-910-0.80-2K) (Product name: MSC1201-xxGS-2K)
xx indicates the code number

BLOCK DIAGRAM

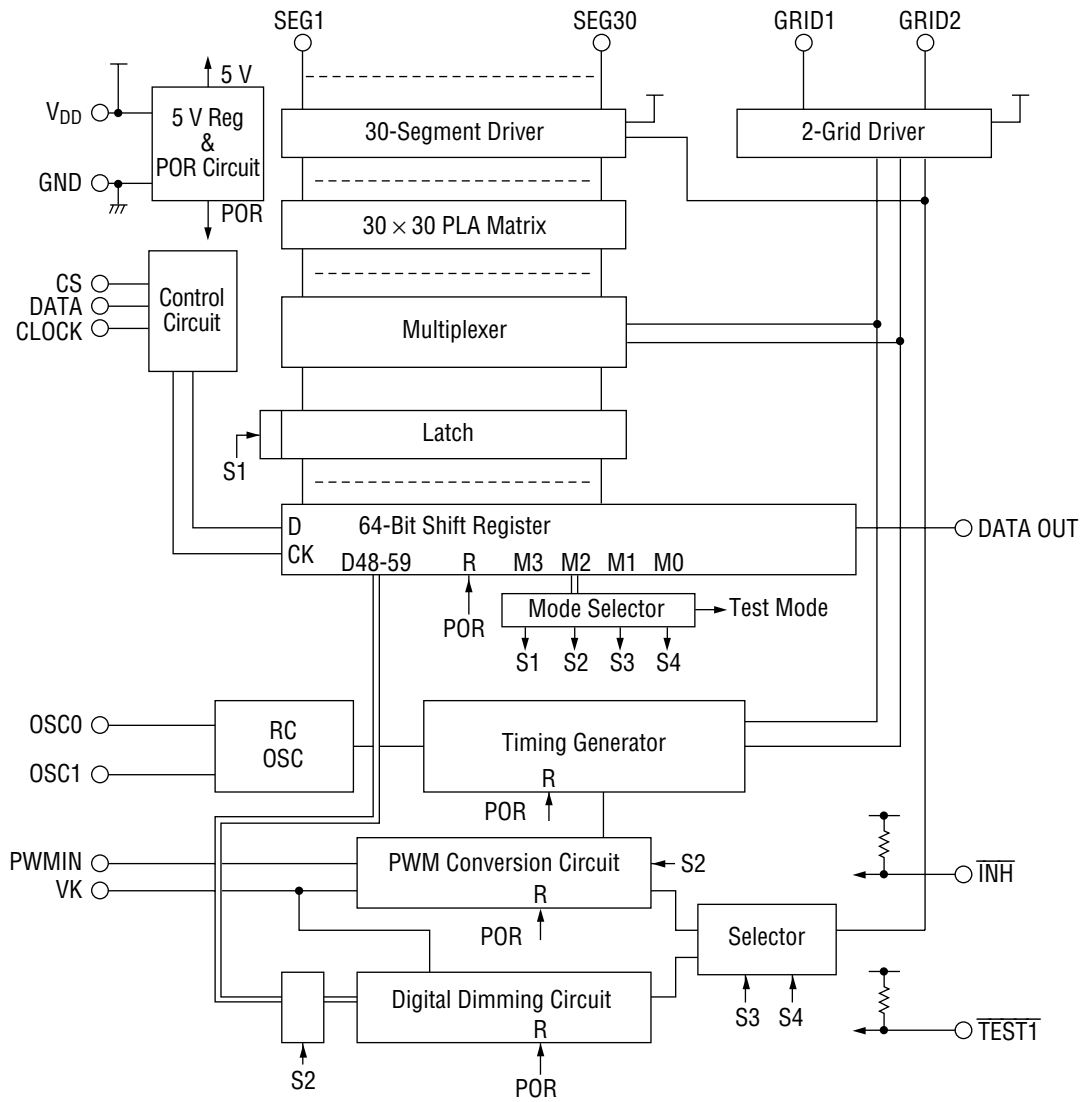

INPUT AND OUTPUT CONFIGURATION

- Schematic Diagrams of Logic Portion Input Circuit 1
- Schematic Diagrams of Logic Portion Input Circuit 1

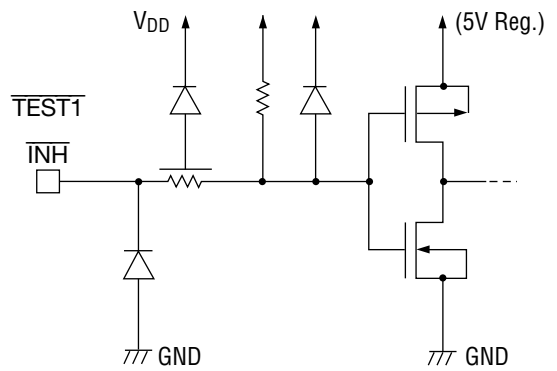
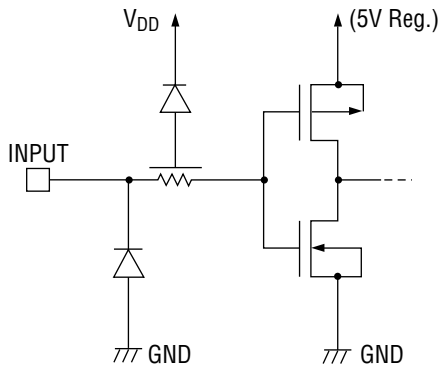

- Schematic Diagrams of Logic Portion Output Circuit
- Schematic Diagrams of Driver Output Circuit

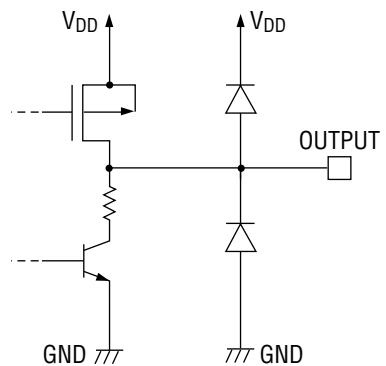
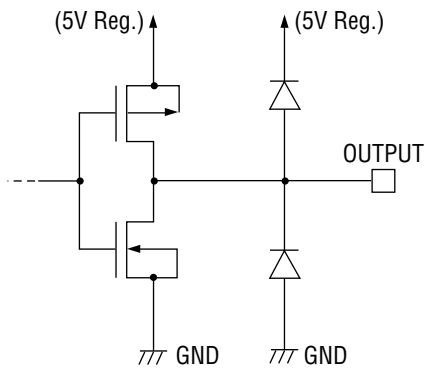

PIN CONFIGURATION (TOP VIEW)

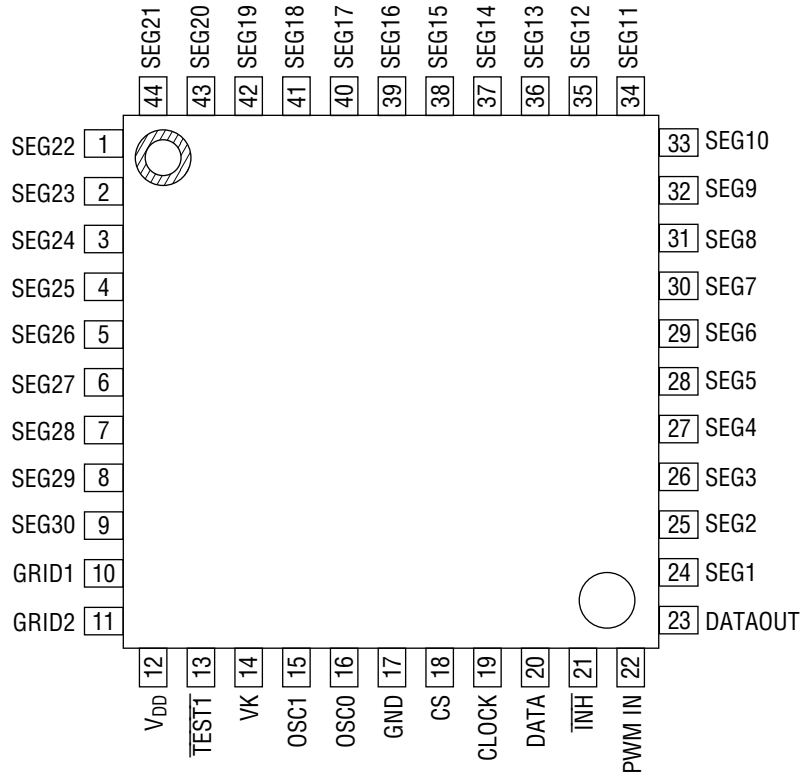

44-Pin Plastic Package

PIN DESCRIPTIONS

Pin	Symbol	I/O	Description
1-9 24-44	SEG1-30	0	Segment output pin for VFD
10, 11	GRID1, 2	0	Grid 1 and Grid 2 output pins for VFD
16	OSC0	I	RC oscillation pins. Connect a resistor between OSC1 and OSC0 pin and a capacitor between OSC0 and GND pin.
15	OSC1	0	
18	CS	I	Chip select input. Only when the high level is input to this pin, interfacing with a MCU is available through "CLOCK" and "DATA" pins. Therefore, 2-signal lines of "CLOCK" and "DATA" can be shared with other peripherals.
20	DATA	I	Input which receives display data and digital dimming data from a MCU. Data is shifted in at the rising edge of the shift clock.
19	CLOCK	I	Serial clock input. Data that is input through "DATA" pin is input and output by synchronization with the rising edge of the serial clock.
23	DATA OUT	0	Serial data output. Data is shifted out at the rising edge of the serial clock with the delay of 64-bit time. This pin is used for cascading this LSI with other drivers such as a LED driver.
22	PWMIN	I	PWM signal input.
14	VK	I	Dimming select input. When the high level is input, daylight-mode output duty cycle is about 100% for each grid time for PWM conversion and digital dimming mode. When the low level is input, the dark-mode output duty cycle is determined by the duty cycle of the PWM signal input to PWM IN and the digital dimming output duty cycle is determined by digital dimming data.
21	$\overline{\text{INH}}$	I	Blank Display input with a built-in pull-up resistor. When set to "L", all the drivers output "L". When display duty is not controlled by this signal, leave this pin open.
13	$\overline{\text{TEST1}}$	I	Test signal input pin. As this pin is used for shipping test of the LSI, leave open in the normal operation mode.
12	V _{DD}	—	Power Supply
17	GND	—	Ground

ABSOLUTE MAXIMUM RATINGS

Parameter	Symbol	Condition	Rating	Unit
Supply Voltage	V _{DD}	—	-0.3 to +20	V
Input Voltage	V _{IN}	All inputs	-0.3 to +6	V
Storage Temperature Range	T _{STG}	—	-65 to +150	°C
Power Dissipation	P _D	T _a = 85°C	0.4	W

RECOMMENDED OPERATING CONDITIONS

Parameter	Symbol	Condition	Min.	Typ.	Max.	Unit
Supply Voltage	V _{DD}	—	8	—	18	V
High Level Input Voltage (1)	V _{IH1}	All inputs except OSC0, VK	3.8	—	5.5	V
High Level Input Voltage (2)	V _{IH2}	VK	3.8	—	V _{DD}	V
High Level Input Voltage (3)	V _{IH3}	OSC0	4.5	—	5.5	V
Low Level Input Voltage (1)	V _{IL1}	All inputs except OSC0	0	—	0.8	V
Low Level Input Voltage (2)	V _{IL2}	OSC0	0	—	0.5	V
Clock Frequency	f _C	—	—	—	250	kHz
OSC Frequency	f _{OSC}	R = 4.7kΩ, C=22pF	—	2	—	MHz
Frame Frequency	F _{FR}	f _{OSC} = 2 MHz	—	224	—	Hz
Operating Temperature Range	T _{op}	—	-40	—	85	°C

ELECTRICAL CHARACTERISTICS

DC Characteristics

(Ta = -40 to +85°C, V_{DD} = 8 to 18 V)

Parameter	Symbol	Condition	Min.	Max.	Unit
Hight Level Input Voltage (1) *1	V _{IH1}	—	3.8	5.5	V
Hight Level Input Voltage (2) *9	V _{IH2}	—	3.8	V _{DD}	V
Hight Level Input Voltage (3) *2	V _{IH3}	—	4.5	5.5	V
Low Level Input Voltage (1) *10	V _{IL1}	—	0	0.8	V
Low Level Input Voltage (2) *2	V _{IL2}	—	0	0.5	V
Hight Level Input Current (1) *3	I _{IH1}	V _{IH1} = 5.0 V	-5	5	μA
Hight Level Input Current (2) *4	I _{IH2}	V _{IH2} = 5.0 V	-80	80	μA
Hight Level Input Current (3) *5	I _{IH3}	V _{IH3} = 5.0 V	-60	60	μA
Low Level Input Current (1) *3	I _{IL1}	V _{IL1} = 0.0 V	-5	5	μA
Low Level Input Current (2) *4	I _{IL2}	V _{IL2} = 0.0 V	-0.6	-0.1	mA
Low Level Input Current (3) *5	I _{IL3}	V _{IL3} = 0.0 V	-320	-30	μA
High Level Output Voltage (1) *6	V _{OH1}	V _{DD} = 9.5 V I _{OH1} = -6 mA	V _{DD} -0.8	—	V
High Level Output Voltage (2) *7	V _{OH2}	V _{DD} = 9.5 V I _{OH2} = -30 mA	V _{DD} -0.8	—	V
High Level Output Voltage (3) *8	V _{OH3-1}	V _{DD} = 9.5 V I _{OH3-1} = -200 μA	4	6	V
	V _{OH3-2}	V _{DD} = 9.5 V Output Open	4.5	6	V
Low Level Output Voltage (1) *6 *7	V _{OL1-1}	V _{DD} = 9.5 V I _{OL1-1} = 500 μA	—	2	V
	V _{OL1-2}	V _{DD} = 9.5 V I _{OL1-2} = 200 μA	—	1	V
	V _{OL1-3}	V _{DD} = 9.5 V I _{OL1-3} = 2 μA	—	0.3	V
Low Level Output Voltage (2) *8	V _{OL2}	V _{DD} = 9.5 V I _{OL2} = 200 μA	—	0.8	V
Power Supply Current	I _{DD}	f _{osc} = 2 MHz, No load	—	20	mA

- Notes: *1 Applicable to all input pins (except VK, OSC0 pin)
 *2 Applicable to OSC0 pin
 *3 Applicable to CLOCK, DATA, CS, VK, and PWMIN pin
 *4 Applicable to $\overline{\text{TEST1}}$
 *5 Applicable to $\overline{\text{INH}}$ pin
 *6 Applicable to pins SEG1 to SEG30
 *7 Applicable to GRID1 and GRID2
 *8 Applicable to DATA OUT pin
 *9 Applicable to VK pin
 *10 Applicable to all input pins (except OSC0 pin)

AC Characteristics

(Ta = -40 to +85°C, VDD = 8 to 18 V)

Parameter	Symbol	Condition	Min.	Max.	Unit
Oscillation Frequency	f _{OSC}	R = 4.7kΩ, C = 22pF	1.2	2.8	MHz
OSCO Input Frequency	f _{OSCI}	External input only	1.5	2.5	MHz
Clock Frequency	f _C	—	—	250	kHz
Clock Pulse Width	t _{CW}	—	1.3	—	μs
Data Set-up Time	t _{DS}	—	1	—	μs
Data Hold Time	t _{DH}	—	200	—	ns
CS Pulse Width	t _{CSW}	—	68	—	μs
CS Off Time	t _{CSL}	—	30	—	μs
CS Set-up Time CS-Clock Time	t _{CSS}	—	2	—	μs
CS Hold Time Clock-CS Time	t _{CSH}	—	2	—	μs
Data Output Delay Clock-Data out Time	t _{PD}	—	—	1	μs
SEG & GRID Output Delay from CS	t _{ODS}	C _L = 100pF	—	8	μs
Slew Rate (All Drivers)	t _R	C _L = 100pF, t = 20% to 80% or 80% to 20%	—	5	μs
Power-on CS Time	t _{PCS}	—	300	—	μs
Power-off Hold Time	t _{POF}	When the Unit mounted V _{DD} = 0 V	5	—	ms
Power-on Rise Time	t _{PRZ}	When the Unit mounted	—	100	μs
Frame Frequency	F _{FR}	—	146	342	Hz

PWM Conversion Characteristics

(Ta = -40 to +85°C, VDD = 8 to 18 V)

Parameter	Symbol	Condition	Min.	Typ.	Max.	Unit
PWM Input Frequency	f _{PWM}	—	176	256	336	Hz
Input Threshold Voltage	V _R	—	0.8	2.5	3.8	V
PWM Input Duty Cycle	d _U	—	20	—	100	%

TIMING DIAGRAM

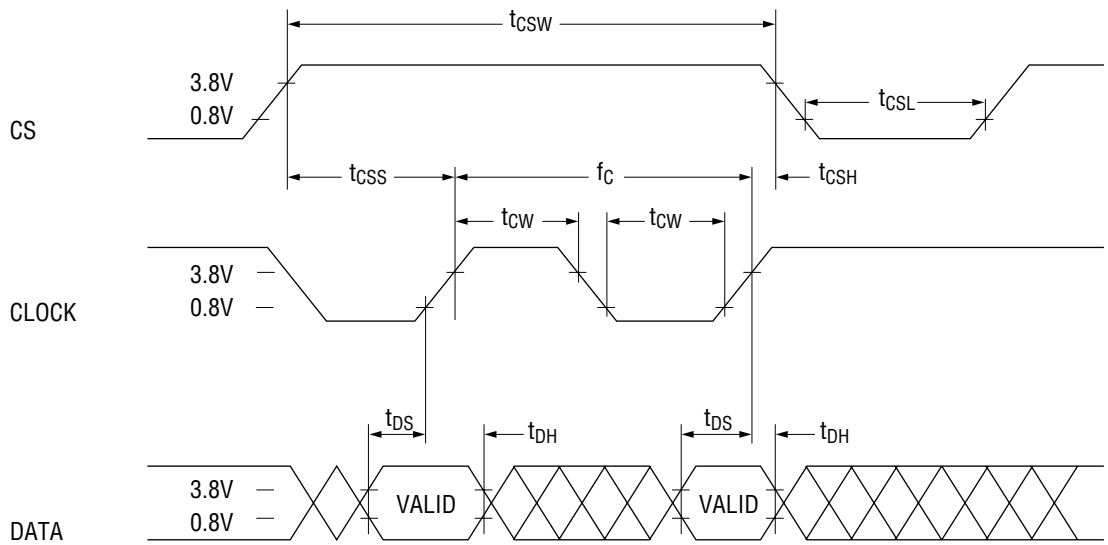

Fig. 1 Data Input Timing

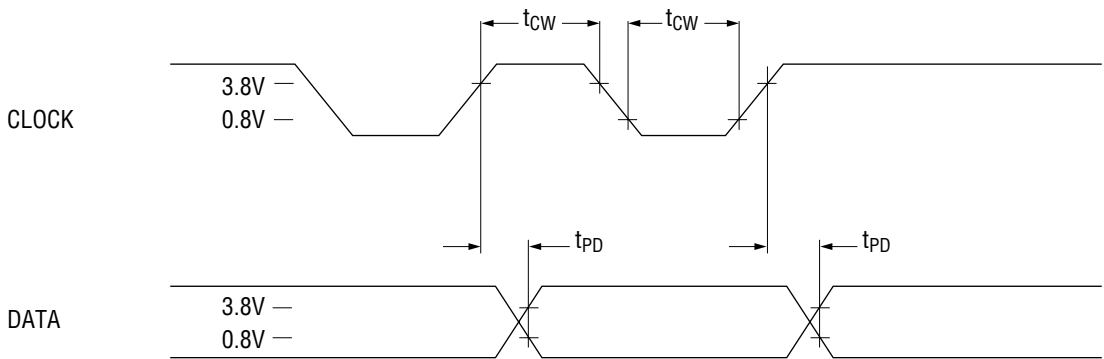

Fig. 2 Data Output Timing

TIMING DIAGRAM (Continued)

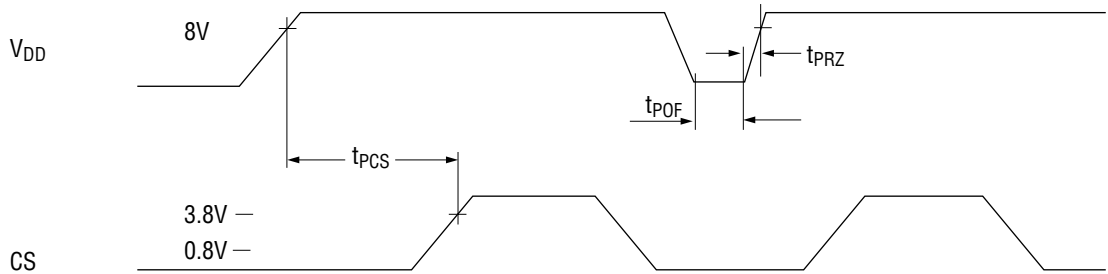

Fig. 3 Power-On Timing

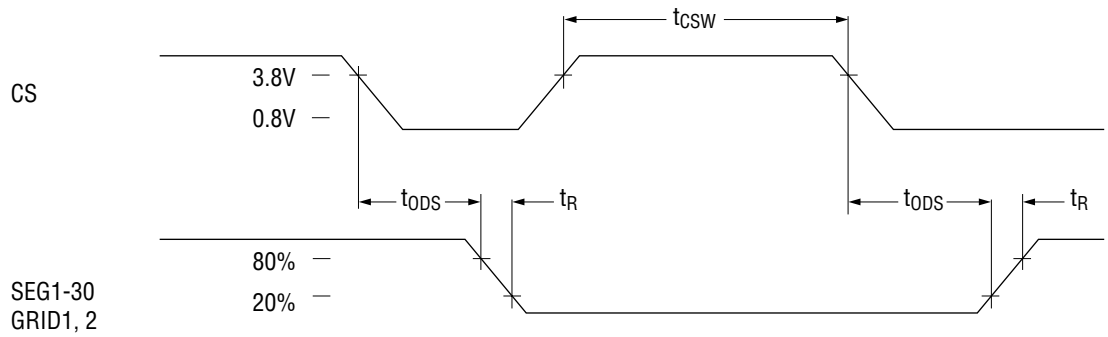

Fig. 4 SEG & GRID Driver Output Timing

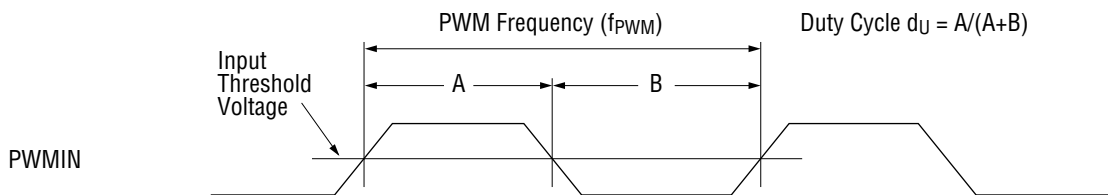

Fig. 5 PWM Input Waveform

FUNCTIONAL DESCRIPTION

Power-On-Reset

The status of the internal circuit after power-on reset is as follows;

- 1) Shift registers and latches are reset.
- 2) PWM conversion mode is selected.

DATA Input

Data input is available only when the high level is applied to the "CS" pin. Input data is shifted into shift registers through "Data" pin at the rising edge of the shift clock. The data is automatically loaded to latches at the falling edge of "CS" signal. When M0 = "0", input data should include display data (total of 64 bits data should be input.) and when M0 = "1", input data should exclude display data (Total of 16-bit data should be input.)

[Data Format]

1) Display Data Input Mode

- Input Data : 64 bits
- VF Display Data : 60 bits
- Mode Select Data : 4 bits

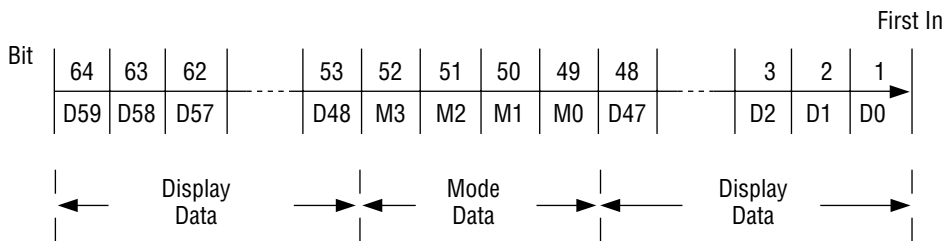

2) Segment outputs/Shift Registers Bit Correspondence Table

The content of the table depends on a PLA code.

This table is modeled on the general purpose code of -01.

Segment output positions can be changed dependent on the PLA code, but the segment-bit correspondence cannot be changed.

	30	29	28	27	26	25	24	23	22	21	20	19	18	17	16	15	14	13	12	11	10	9	8	7	6	5	4	3	2	1	SEGn
Bit	30	29	28	27	26	25	24	23	22	21	20	19	18	17	16	15	14	13	12	11	10	9	8	7	6	5	4	3	2	1	GRID1
	60	59	58	57	56	55	54	53	52	51	50	49	48	47	46	45	44	43	42	41	40	39	38	37	36	35	34	33	32	31	GRID2

3) Digital Dimming Data Input Mode

Input Data : 16 bits
 Digital Dimming Data : 11 bits
 Mode Select Data : 4 bits

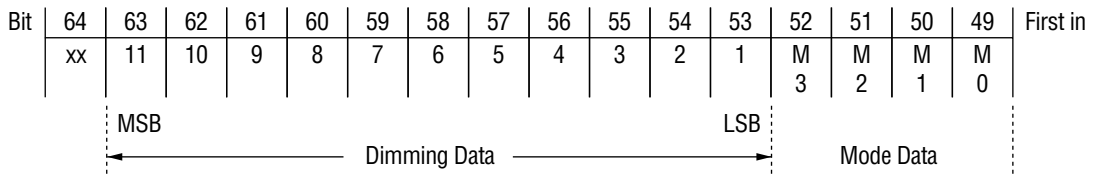

(MSB)	INPUT DATA											(LSB)	DUTY CYCLE	
X	0	0	0	0	0	0	0	0	0	0	0	0	0	0/2048
X	0	0	0	0	0	0	0	0	0	0	0	0	1	1/2048
X	1	1	1	1	1	1	1	0	0	0	0	0	2032/2048	
X	1	1	1	1	1	1	1	1	1	1	1	1	2032/2048	

4) Function Mode

Mode	M3	M2	M1	M0	Function
S1	0	0	0	0	Display Data Input
S2	0	0	0	1	Digital Dimming Data Input
S3	0	0	1	0	PWM Conversion Select & Display Data Input
S4	0	0	1	1	PWM Conversion Select
S5	0	1	0	0	Digital Dimming Select & Display Data Input
S6	0	1	0	1	Digital Dimming Select

PWM Conversion

In the PWM conversion mode, "lamp PWM", which is used for dimming control of back-light for instrument clusters or other displays, is used to generate the PWM signal for VFD tube dimming control. The lamp PWM input to "PWM IN" pin is converted to PWM signal for VFD tube with a built-in PWM conversion look-up table (User-Programmable Mask ROM).

The duty cycle of the lamp PWM is defined as follows:

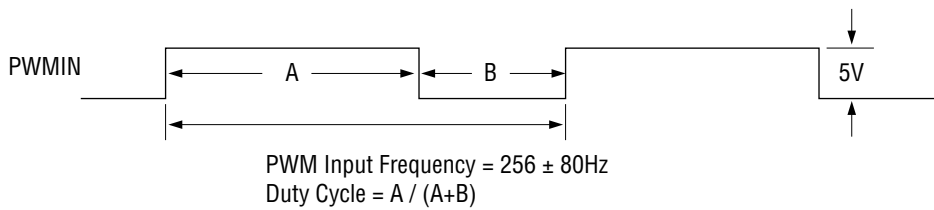

Note: The duty cycle of the lamp PWM signal is measured with a reference point of 2.5 V typ. As the reference point of 2.5 V is the threshold voltage of "PWM IN" pin, it deviates to some value between 0.8 V and 3.8 V due to process parameter deviation. Therefore, the PWM conversion error increases as the rise/fall time of the lamp PWM increases.

GRID/SEG Driver Operation and Digital/Analog Dimming Operation

Figure 6 shows an output timing of the GRID and SEG Driver when the VK is "H" level. Output timings of the GRID and SEG drivers are shown in figure 7 for the digital dimming mode operation in figure 8 for the PWM conversion mode operation.

(1) GRID and SEG drivers output timings when VK = "H"

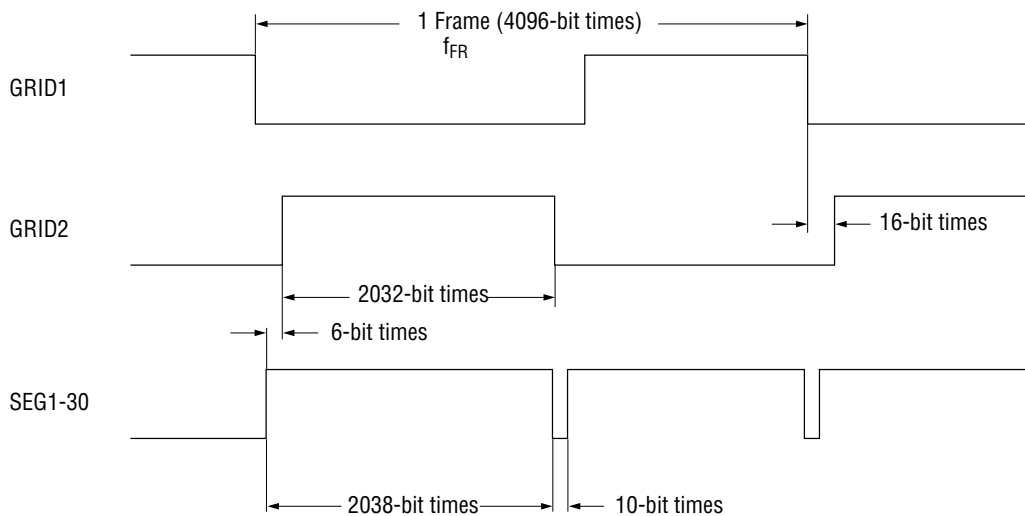

Fig. 6 GRID and SEG Output Timing (VK = "H")

Note: One bit time = $2/f_{OSC} = 1 \mu\text{s}$ typ.

(2) GRID and SEG driver output timing when VK = "L" and in Digital Dimming Mode.

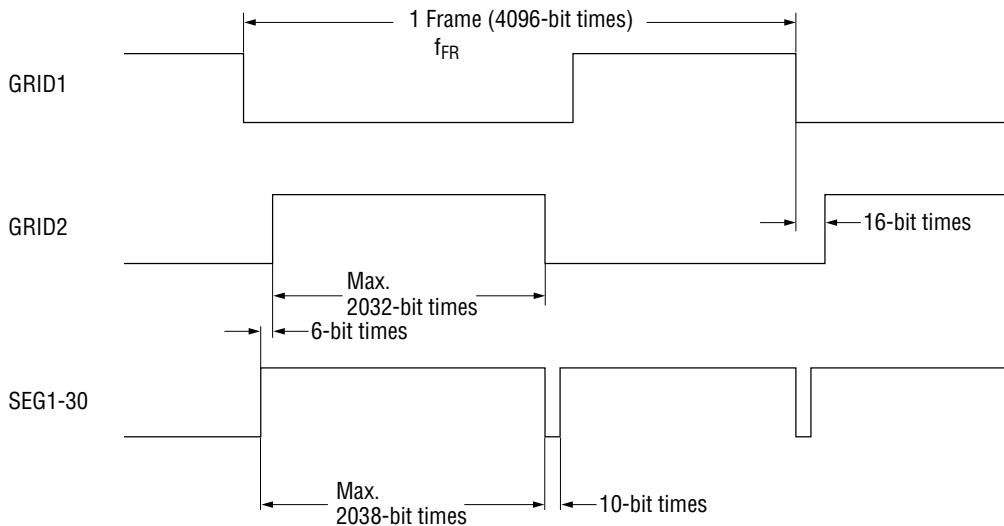

Fig. 7 GRID and SEG Output Timing (digital dimming mode)

- Notes:
- The above indicates the timing for the digital dimming mode with the duty cycle of 2032/2048 at $V_{PARK} = "L"$ level.
 - The On-times for GRID and SEG are specified with the 11 bits of the digital dimming data.
 - One bit time = $2/f_{OSC} = 1 \mu s$ typ.

(3) GRID and SEG driver output timings when VK = "L" and in PWM Conversion Mode

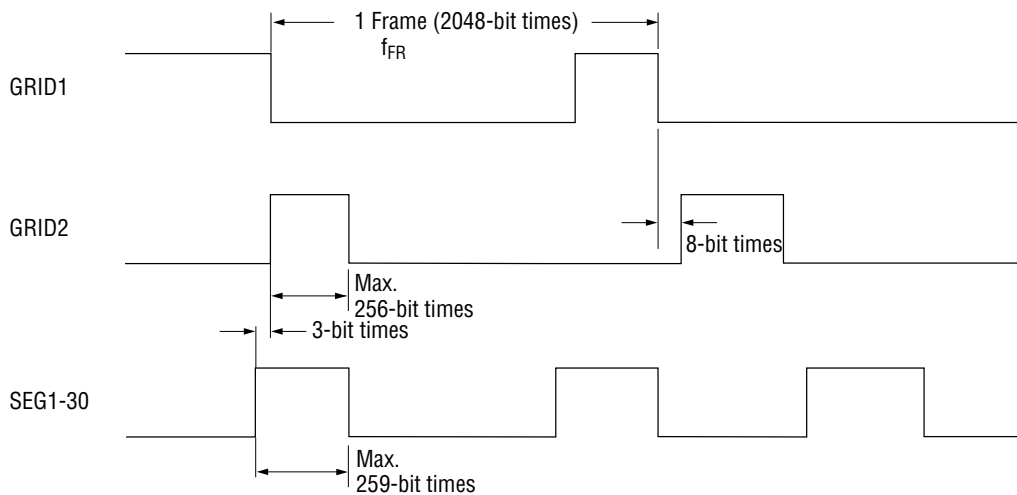

Fig. 8 GRID and SEG Driver Output Timing (PWM conversion mode)

- Notes:
- The above indicates the GRID and SEG Drivers Timing when the PWM conversion mode at VK = "L" level is selected.
 - One bit time = $4/f_{OSC} = 2 \mu s$ typ.

PWM Conversion Table

MSC1201-01

STEP No.	LAMP PWM DUTY CYCLE	VF PWM DUTY CYCLE	STEP No.	LAMP PWM DUTY CYCLE	VF PWM DUTY CYCLE
0	100.00%	12.50%	33	58.75%	6.05%
1	98.75%	12.30%	34	57.50%	5.86%
2	97.50%	12.11%	35	56.25%	5.66%
3	96.25%	11.91%	36	55.00%	5.47%
4	95.00%	11.72%	37	53.75%	5.27%
5	93.75%	11.52%	38	52.50%	5.08%
6	92.50%	11.33%	39	51.25%	4.88%
7	91.25%	11.13%	40	50.00%	4.69%
8	90.00%	10.94%	41	48.75%	4.49%
9	88.75%	10.74%	42	47.50%	4.30%
10	87.50%	10.55%	43	46.25%	4.10%
11	86.25%	10.35%	44	45.00%	3.91%
12	85.00%	10.16%	45	43.75%	3.71%
13	83.75%	9.96%	46	42.50%	3.52%
14	82.50%	9.77%	47	41.25%	3.32%
15	81.25%	9.57%	48	40.00%	3.13%
16	80.00%	9.38%	49	38.75%	2.93%
17	78.75%	9.18%	50	37.50%	2.73%
18	77.50%	8.98%	51	36.25%	2.54%
19	76.25%	8.79%	52	35.00%	2.34%
20	75.00%	8.59%	53	33.75%	2.15%
21	73.75%	8.40%	54	32.50%	1.95%
22	72.50%	8.20%	55	31.25%	1.76%
23	71.25%	8.01%	56	30.00%	1.56%
24	70.00%	7.81%	57	28.75%	1.37%
25	68.75%	7.62%	58	27.50%	1.17%
26	67.50%	7.42%	59	26.25%	0.98%
27	66.25%	7.23%	60	25.00%	0.78%
28	65.00%	7.03%	61	23.75%	0.59%
29	63.75%	6.84%	62	22.50%	0.39%
30	62.50%	6.64%	63	21.25%	0.20%
31	61.25%	6.45%	64	20.00%	0.10%
32	60.00%	6.25%			

PLA Code Table

MSC1201-01

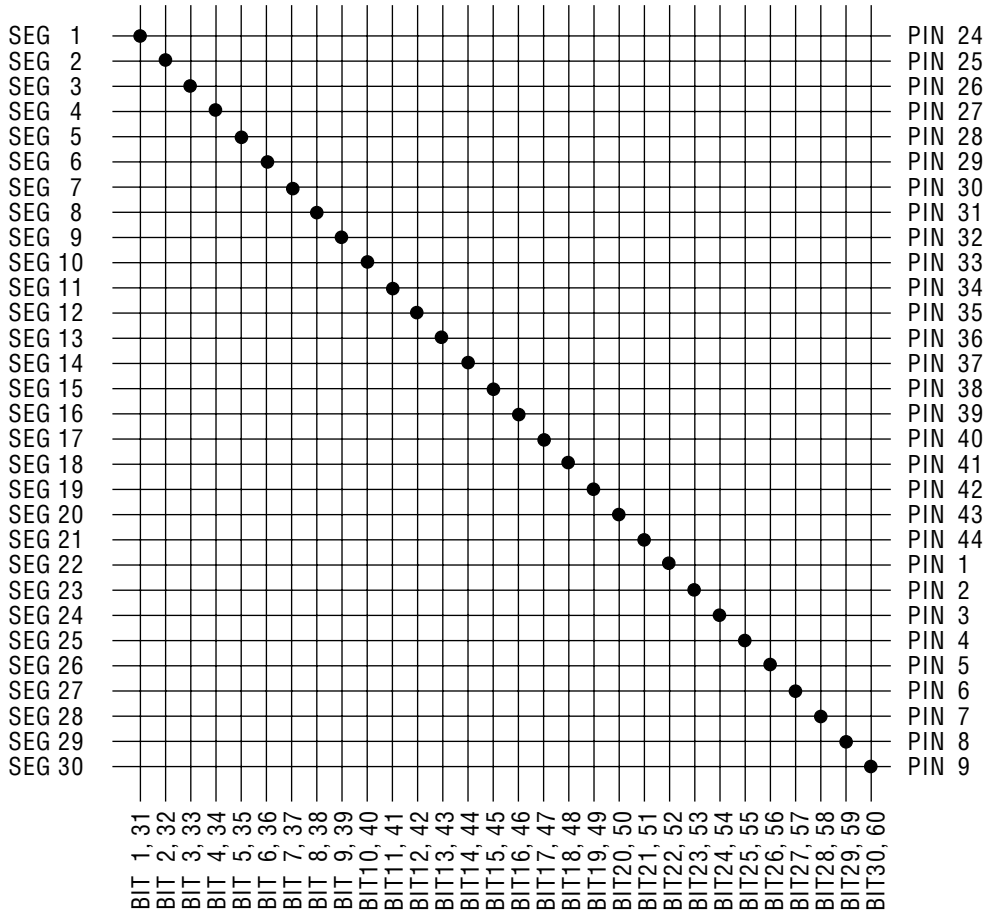

Pin Name	Output	Pin Name	Output
SEG1	BIT 1,31	SEG16	BIT 16,46
SEG2	BIT 2,32	SEG17	BIT 17,47
SEG3	BIT 3,33	SEG18	BIT 18,48
SEG4	BIT 4,34	SEG19	BIT 19,49
SEG5	BIT 5,35	SEG20	BIT 20,50
SEG6	BIT 6,36	SEG21	BIT 21,51
SEG7	BIT 7,37	SEG22	BIT 22,52
SEG8	BIT 8,38	SEG23	BIT 23,53
SEG9	BIT 9,39	SEG24	BIT 24,54
SEG10	BIT 10,40	SEG25	BIT 25,55
SEG11	BIT 11,41	SEG26	BIT 26,56
SEG12	BIT 12,42	SEG27	BIT 27,57
SEG13	BIT 13,43	SEG28	BIT 28,58
SEG14	BIT 14,44	SEG29	BIT 29,59
SEG15	BIT 15,45	SEG30	BIT 30,60

APPLICATION CIRCUITS

(1) Digital Dimming Mode

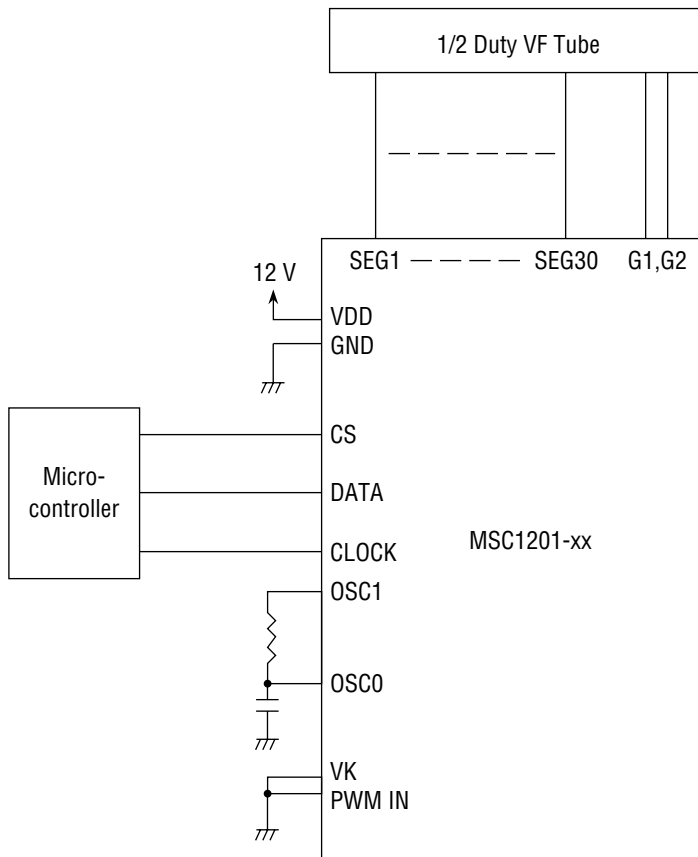

(2) PWM Conversion Mode

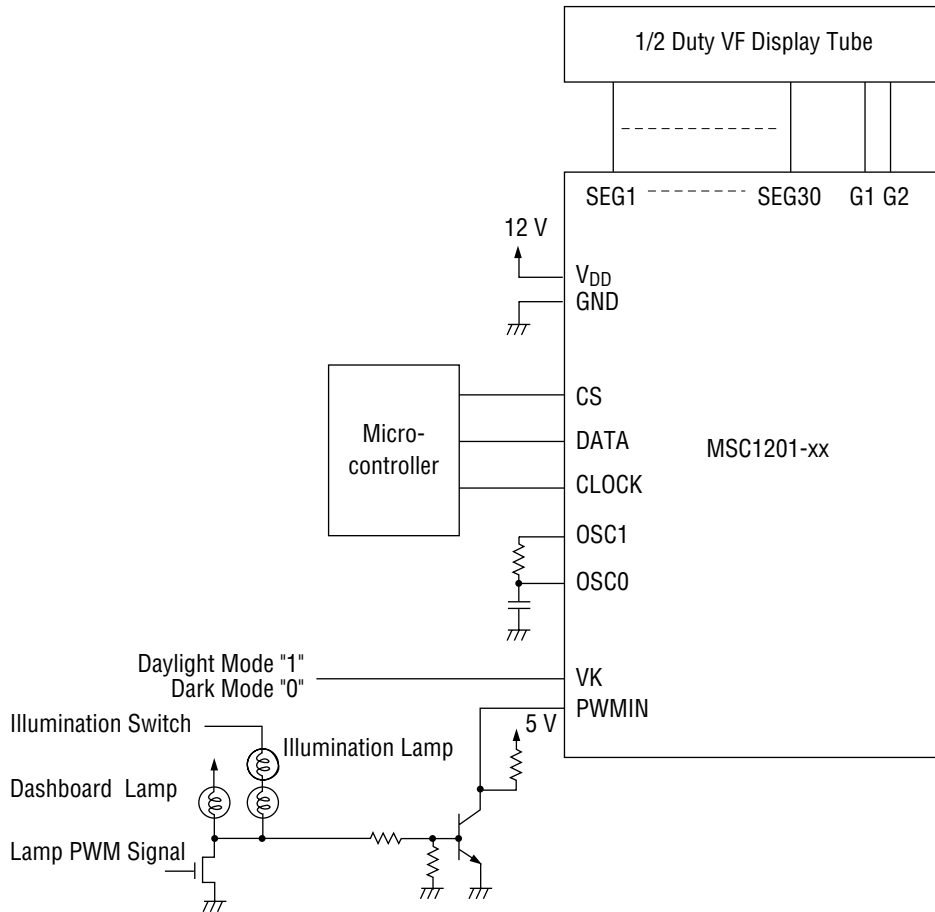

PACKAGE DIMENSIONS

(Unit : mm)

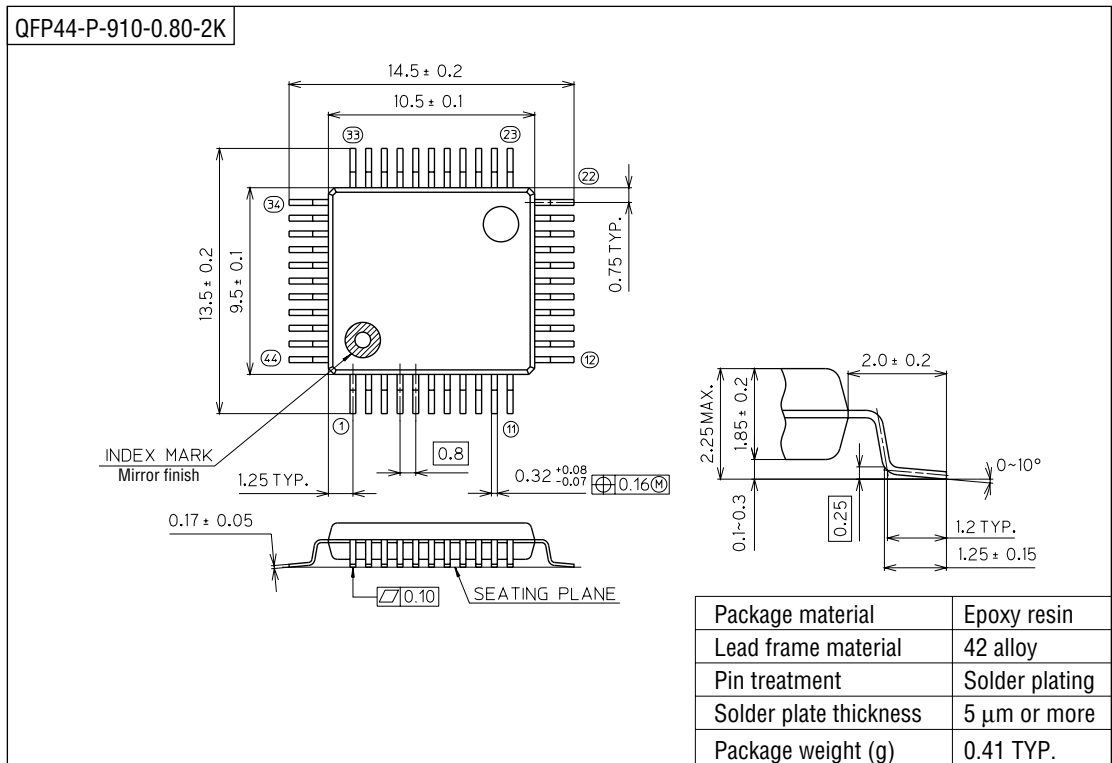

Notes for Mounting the Surface Mount Type Package

The SOP, QFP, TSOP, SOJ, QFJ (PLCC), SHP and BGA are surface mount type packages, which are very susceptible to heat in reflow mounting and humidity absorbed in storage. Therefore, before you perform reflow mounting, contact Oki's responsible sales person for the product name, package name, pin number, package code and desired mounting conditions (reflow method, temperature and times).