

Timing Characteristics

Table 5-9. 41LV, 41LW, and 41LX Timing Characteristics (Driver) (See Figures 6-1 and 6-2.)

Propagation-delay test circuit is connected to output (see Figure 6-6).

$T_A = 25\text{ }^\circ\text{C}$, $V_{CC} = 5\text{ V}$.

Symbol	Parameter	Typ	Max	Unit
t _{P1} t _{P2}	Propagation Delay:			
	Input High to Output	3.0	4.5	ns
	Input Low to Output	3.0	4.5	ns
t _{PHZ} t _{PLZ}	Disable Time:			
	High to High Impedance	10	15	ns
	Low to Low Impedance	10	15	ns
t _{PZH} t _{PZL}	Enable Time:			
	High Impedance to High	10	15	ns
	High Impedance to Low	10	15	ns
t _{skew}	Output Skew, t _{P1} – t _{P2}	0.2	0.5	ns
Δt _{skew}	Difference Between Drivers	0.3	—	ns

Table 5-10. 41LV, 41LW, and 41LX Timing Characteristics (Receiver) (See Figures 6-3 and 6-4.)

Propagation-delay test circuit is connected to output (see Figure 6-8).

$T_A = 25\text{ }^\circ\text{C}$, $V_{CC} = 5\text{ V}$.

Symbol	Parameter	Typ	Max	Unit
t _{PLH} t _{PHL}	Propagation Delay:			
	Input to Output High	3.5	7	ns
	Input to Output Low	3.5	7	ns
t _{PHZ} t _{PLZ}	Disable Time, C _L = 5 pF:			
	High to High Impedance	10	15	ns
	Low to High Impedance	10	15	ns
t _{PZH} t _{PZL}	Enable Time, C _L = 5 pF:			
	High Impedance to High	10	15	ns
	High Impedance to Low	10	15	ns

41MK, 41ML, and 41MM Dual Differential Transceivers

Features

Driver Features:

- Two line drivers per package
- Logic converts TTL input logic levels to differential, pseudo-ECL output logic levels
- No line loading when $V_{cc} = 0$ V
- High output drive for 50 Ω lines
- 2.0 mA short-circuit current (typical)
- 2.0 ns maximum propagation delay
- <0.2 ns output skew (typical)

Receiver Features:

- Two line receivers per package
- High input impedance ≈ 8 k Ω^*
- Logic which converts differential input logic levels to TTL output logic levels
- 4.0 ns maximum propagation delay
- <0.20 V input sensitivity (typical)
- -1.2 to +7.2 V common-mode range

Common Device Features:

- Common enable for each driver pair and receiver pair
- 0 $^{\circ}$ C to 85 $^{\circ}$ C ambient operating temperature (See Section 9.)
- Single 5 V supply
- 200 Mbits/s or 400 Mbits/s maximum data rates when used with the 41Lx and 41Mx devices respectively
- Meets ESDI standards

Description

The 41MK, 41ML, and 41MM devices are dual differential transceiver circuits that transmit and receive digital data over balanced transmission lines and are compatible with 41 Series drivers and receivers. The dual receivers convert differential input logic levels to TTL output levels. The dual drivers translate input TTL logic levels to differential, pseudo-ECL output levels. Each driver pair and receiver pair has its own common enable control allowing serial data and a control clock to be transmitted and received on a single integrated circuit.

The 41MK transceiver requires the customer to supply termination resistors on the circuit board. The 41ML transceiver has an internal 220 Ω termination resistor connected to ground on each driver output and is equivalent to the 8923A device. The 41MM transceiver has an internal resistor termination for both the driver outputs (220 Ω) and receiver inputs (110 Ω), eliminating the need for external resistors on the circuit board when used with 100 Ω impedance, twisted-pair (or flat) cable.

The packaging options that are available for the dual differential transceivers include a 16-pin DIP (41MK, 41ML, 41MM), a 16-pin J-lead SOJ (1041MK, 1041ML, 1041MM), a 16-pin gull-wing SOIC (1141MK, 1141ML, 1141MM), and a 16-pin narrow-body gull-wing SOIC (1241MK, 1241ML, 1241MM).

* Except 41MM which has built-in resistors

Pin Information

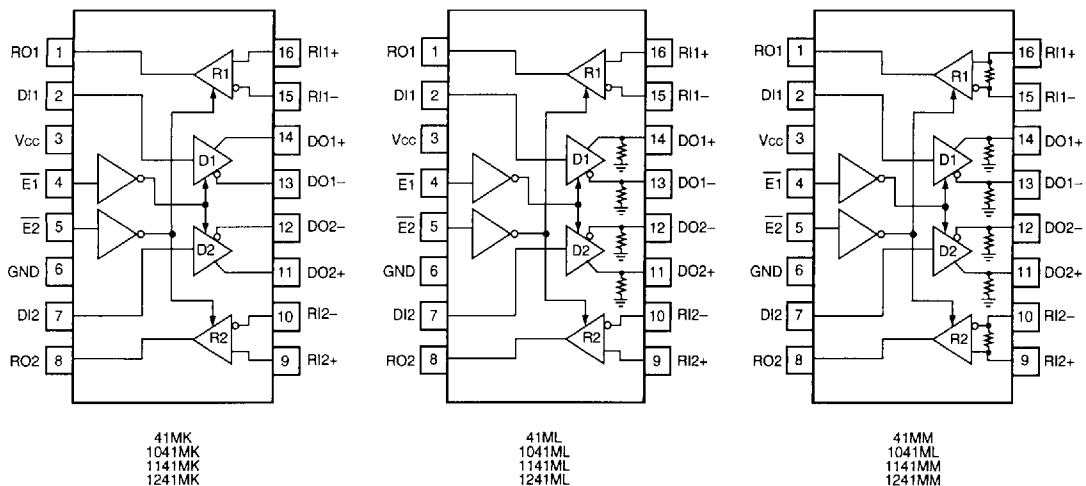

12-2747C

Figure 5-3. 41MK, 41ML, and 41MM Logic Diagrams

Enable Truth Table

E1	E2	DO1	DO2	RO1	RO2
0	0	Active	Active	Active	Active
1	0	Disabled	Disabled	Active	Active
0	1	Active	Active	Disabled	Disabled
1	1	Disabled	Disabled	Disabled	Disabled

Absolute Maximum Ratings

Stresses in excess of the Absolute Maximum Ratings can cause permanent damage to the device. These are absolute stress ratings only. Functional operation of the device is not implied at these or any other conditions in excess of those given in the operational sections of the data sheet. Exposure to Absolute Maximum Ratings for extended periods can adversely affect device reliability.

Parameter	Symbol	Min	Max	Unit
Power Supply Voltage	V _{CC}	—	7.0	V
Ambient Operating Temperature	T _A	0	85	°C
Storage Temperature	T _{stg}	-40	125	°C

Handling Precautions

CAUTION: This device is susceptible to damage as a result of electrostatic discharge. Take proper precautions during both handling and testing. Follow guidelines such as JEDEC Publication No. 108-A (Dec. 1988).

AT&T employs a human-body model (HBM) for ESD-susceptibility testing and protection design evaluation. ESD voltage thresholds are dependent on the critical parameters used to define the model. 41 Series

receiver differential inputs are not equipped with ESD protection. The standard HBM (resistance = 1.5 kΩ, capacitance = 100 pF) is used. The HBM ESD threshold voltages presented here were obtained using this circuit.

HBM ESD Threshold Voltage	
Device	Rating
41 Series Receiver	
Differential Inputs (MK, ML)	>500 V
(MM)	>750 V
All other pins	>1000 V

Electrical Characteristics

Table 5-11. 41MK, 41ML, and 41MM Power Supply Current Characteristics

T_A = 0 °C to 85 °C, V_{CC} = 5 V ± 0.5 V.

Parameter	Symbol	Min	Typ	Max	Unit
Power Supply Current:					
41MK					
All Outputs Disabled	I _{CC}	—	55	80	mA
All Outputs Enabled	I _{CC}	—	35	50	mA
41ML and 41MM					
All Outputs Disabled	I _{CC}	—	100	135	mA
All Outputs Enabled	I _{CC}	—	100	135	mA

Electrical Characteristics (continued)

Table 5-12. 41MK, 41ML, and 41MM Voltage and Current Characteristics (Driver)

T_A = 0 °C to 85 °C.

Parameter	Symbol	Min	Typ	Max	Unit
Output Voltages, V _{CC} = 4.5 V:					
Low, I _{OL} = -8.0 mA*	V _{OL}	—	3.0	V _{OH} - 0.8†	V
High, I _{OH} = -40.0 mA*	V _{OH}	3.0	4.0	—	V
High Z, I _{OH} = -1.0 mA, V _{CC} = 4.75 V	V _{OZ}	—	2.0	V _{OL} - 0.02	V
Input Voltages:					
Low, V _{CC} = 5.5 V	V _{IL} ‡	—	—	0.7	V
High, V _{CC} = 4.5 V	V _{IH} ‡	2.0	—	—	V
Clamp, V _{CC} = 4.5 V, I _{IN} = -5.0 mA	V _{IK}	—	—	-1.5	V
Short-circuit Output Current, V _{CC} = 5.5 V	I _{OS} §	-100	-250	-350	mA
Input Currents, V _{CC} = 5.5 V:					
Low, V _{IN} = 0.4 V	I _{IL}	—	—	-400	μA
High, V _{IN} = 2.7 V	I _{IH}	—	—	20	μA
Reverse, V _{IN} = 5.5 V	I _{IH}	—	—	100	μA
Output Resistors (41ML, 41MM)	R _O	—	220	—	Ω

* Typical value of the output current for the 41MK, 41ML, and 41MM when terminated per Figure 6-5.

† V_{OL} must be a minimum of 0.8 V less than its complementary output.

‡ The input levels provide zero noise immunity and should be tested only in a static, noise-free environment.

§ Test must be performed one lead at a time to prevent damage to the device.

Table 5-13. 41MK, 41ML, and 41MM Voltage and Current Characteristics (Receiver)

T_A = 0 °C to 85 °C.

Parameter	Symbol	Min	Typ	Max	Unit
Output Voltage, V _{CC} = 4.5 V:					
Low, I _{OL} = 8.0 mA*	V _{OL}	—	—	0.5	V
High, I _{OH} = -400 μA	V _{OH}	2.5	—	—	V
Enable Input Voltages:					
Low, V _{CC} = 5.5 V	V _{IL} *	—	—	0.7	V
High, V _{CC} = 4.5 V	V _{IH} *	2.0	—	—	V
Minimum Differential Input Voltage, V _{IH} - V _{IL} :†					
-0.80 V < V _{IH} < 7.2 V, -1.2 V < V _{IL} < 6.8 V	V _{TH} *	—	0.1	0.20	V
Output Currents, V _{CC} = 5.5 V:					
Off-state (high Z), V _O = 0.4 V	I _{OZL}	—	—	-20	μA
Off-state (high Z), V _O = 2.4 V	I _{OZH}	—	—	20	μA
Short Circuit	I _{OS} ‡	-25.0	—	-100	mA
Enable Input Currents, V _{CC} = 5.5 V:					
Low, V _{IN} = 0.4 V	I _{IL}	—	—	-400	μA
High, V _{IN} = 2.7 V	I _{IH}	—	—	20	μA
Reverse, V _{IN} = 5.5 V	I _{IH}	—	—	100	μA
Differential Input Currents (41MK, 41ML)					
Low, V _{IN} = -1.2 V	I _{IL}	—	—	-1.0	mA
High, V _{IN} = 7.2 V	I _{IH}	—	—	1.0	mA
Differential Input Impedance (41MM)					
Connected Between RI ⁺ and RI ⁻	R _I	—	110	—	Ω

* The input levels and difference voltage provide zero noise immunity and should be tested only in a static, noise-free environment.

† Outputs of unused receivers assume a logic 1 level when the inputs are left open.

‡ Test must be performed one lead at a time to prevent damage to the device.