



DP8483 TTL to 100k ECL Level Translator with Latch

General Description

This circuit translates TTL input levels to ECL output levels and provides a fall-through latch. The outputs are gated with CS providing for wire ORing of outputs. The strobe and chip select inputs operate at ECL levels.

Features

- 16-pin DIP or S.O.
- ECL control inputs
- CS provided for wire ORing of output bus
- 100k ECL I/O compatible
- 3.0 ns typical propagation delay

Logic and Connection Diagram

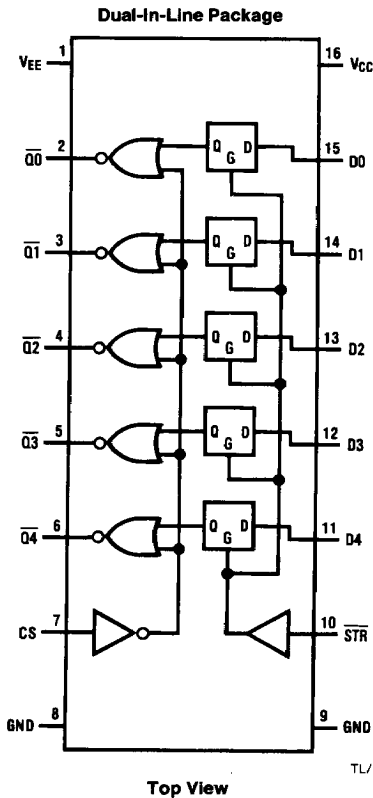

Truth Table

D	\bar{Q}	\overline{STR}	CS
H	L	L	H
L	H	L	H
X	\bar{Q}	H	H
X	L	X	L

H=high level (most positive)
 L=low level (most negative)
 X=don't care

**Order Number DP8483J,
 DP8483M or DP8483N
 See NS Package Number J16A, M16B or N16A**

Absolute Maximum Ratings (Note 1)

If Military/Aerospace specified devices are required, please contact the National Semiconductor Sales Office/Distributors for availability and specifications.

V _{EE} Supply Voltage	-8V
V _{CC} Supply Voltage	7V
Input Voltage (ECL)	GND to V _{EE}
Input Voltage (TTL)	-1V to 5.5V
Output Current	50 mA

Maximum Power Dissipation* at 25°C	1476 mW
Molded Package	
Storage Temperature	-65°C to +150°C
*Derate molded package 11.8 mW/°C above 25°C.	

Recommended Operating Conditions

V _{EE} Supply Voltage	-4.5V ± 7%
V _{CC} Supply Voltage	5.0V ± 10%
T _A , Ambient Temperature	0°C to 85°C

Electrical Characteristics (TTL Logic) (Notes 2 and 3)

Symbol	Parameter	Conditions	Min	Typ	Max	Units
V _{IL}	Input Low Voltage				0.8	V
V _{IH}	Input High Voltage		2.0			V
I _{IL}	Input Low Current	V _{IN} = 0.5V		-25	-200	μA
I _{IH}	Input High Current	V _{IN} = 2.5V		1.0	40	μA
V _{CLAMP}	Input Clamp Voltage	I _{IN} = -12 mA		-0.9	-1.2	V
I _{CC}	Supply Current	V _{CC} = 5.5V		10	20	mA

Electrical Characteristics (ECL Logic) (Notes 2 and 3)

Symbol	Parameter	Conditions	Min	Typ	Max	Units
V _{IL}	Input Low Voltage	V _{EE} = -4.5V	-1810		-1475	mV
V _{IH}	Input High Voltage	V _{EE} = -4.5V	-1165		-880	mV
I _{IL}	Input Low Current	V _{IN} = -1.8V		45	150	μA
I _{IH}	Input High Current	V _{IN} = -0.8V		75	200	μA
V _{OL}	Output Low Voltage	V _{EE} = -4.5V	-1810	-1705	-1620	mV
V _{OH}	Output High Voltage	V _{EE} = -4.5V	-1025	-955	-880	mV
V _{OLC}	Output Low Voltage	V _{EE} = -4.5V			-1610	mV
V _{OHc}	Output High Voltage	V _{EE} = -4.5V	-1035			mV
I _{EE}	Supply Current	V _{EE} = -4.8V		-65	-85	mA

Switching Characteristics (Notes 2 and 4)

Symbol	Parameter	Conditions	Min	Typ	Max	Units
t _{PD1}	Strobe To Output Delay	(Note 4)	1.5	3.0	6.0	ns
t _{PD2}	Data To Output Delay		2.5	4.5	7.5	ns
t _S	Data Set-Up Time to Strobe		5.0	2.0		ns
t _H	Data Hold Time		1.0	0		ns
t _{PW}	Strobe Pulse Width		5.0	3.0		ns
t _{PD3}	Chip Select to Output Delay		1.0	2.5	4.0	ns
t _{SCS}	Data Set-Up Time to Chip Select		5.5	3.0		ns

Note 1: "Absolute Maximum Ratings" are those values beyond which the safety of the device cannot be guaranteed. They are not meant to imply that the device should be operated at these limits. The table of "Electrical Characteristics" provides conditions for actual device operation.

Note 2: Unless otherwise specified, min/max limits apply across the 0°C to 85°C ambient temperature range in still air and across the specified supply variations. All typical values are for 25°C and nominal supply.

Note 3: All currents into device pins are shown as positive; all currents out of device pins are shown as negative. All voltages are referenced to ground, unless otherwise specified.

Note 4: Unless otherwise specified, all AC measurements are referenced from the 1.5V level of the TTL input and to/from the 50% point of the ECL signal and a 50Ω resistor to -2V is the load. ECL input rise and fall times are 0.7 ns ± 0.1 ns from 20% to 80%. TTL input characteristics is 0V to 3V with t_r = t_f ≤ 3 ns measured from 10% to 90%.

Switching Time Waveforms

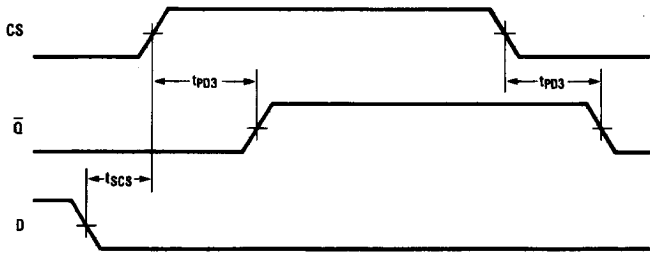

TL/F/5864-2

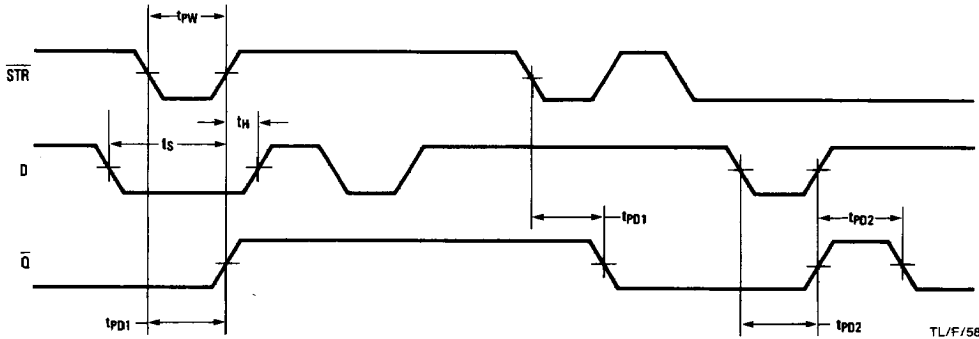

TL/F/5864-3