

SG1000R22

GATE TURN-OFF THYRISTOR SILICON DIFFUSED TYPE

CHOPPER, INVERTER, MOTOR CONTROL APPLICATION.

FEATURES:

- . Repetitive Peak Off-State Voltage : $V_{DRM}=1300V$
- . Repetitive Peak Reverse Voltage : $V_{RRM}=100V$
- . R.M.S On-State Current : $I_T(RMS)=250A$
- . Peak Turn-Off Current : $I_{TQGM}=1000A$
- . Critical Rate of Rise of On-State Current : $di/dt=200A/\mu s$
- . Critical Rate of Rise of Off-State Voltage : $dv/dt=350V/\mu s$
- . Flat Package

MAXIMUM RATINGS

CHARACTERISTIC	SYMBOL	RATING	UNIT
Repetitive Peak Off-State Voltage	V_{DRM}	1300	V
Repetitive Peak Reverse Voltage	V_{RRM}	100	V
Peak Turn-Off Current (Note 2)	I_{TQGM}	1000	A
R.M.S On-State Current	$I_T(RMS)$	250	A
Peak One Cycle Surge On-State Current (Non-Repetitive)	I_{TSM}	5000(50Hz)	A
		5500(60Hz)	
Critical Rate of Rise of On-State Current (Note 1)	di/dt	200	A/ μs
Peak Forward Gate Power Dissipation	P_{FGM}	20	W
Peak Reverse Gate Power Dissipation	P_{RGM}	8	KW
Average Forward Gate Power Dissipation	$P_{G(AV)}$	4	W
Peak Forward Gate Current	I_{FGM}	10	A
Peak Reverse Gate Voltage	V_{RGM}	15	V
Storage Temperature Range	T_{stg}	-40 ~ 115	$^{\circ}C$
Operating Junction Temperature Range	T_j	-40 ~ 115	$^{\circ}C$
Mounting Force	-	1200 \pm 120	kg

Note 1 : $V_j=1/2$ Rated, Gate Supply ($I_G=5A$, $t_r \leq 1\mu s$), $f=50Hz$.

Unit in mm

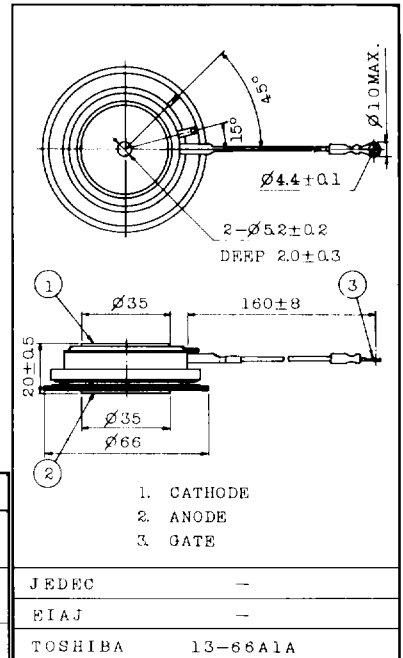

Weight : 260g

ELECTRICAL CHARACTERISTICS

CHARACTERISTIC	SYMBOL	TEST CONDITION	MIN.	TYP.	MAX.	UNIT	
Repetitive Peak Off-State Current	I _{DRM}	V _{DRM} , V _{RRM} =Rated R _{GK} =20Ω, T _j =115°C	-	-	50	mA	
Repetitive Peak Reverse Current	I _{RRM}		-	-	50	mA	
Peak On-State Voltage	V _{TM}	I _{TM} =1000A, T _c =25°C	-	-	2.8	V	
Gate Trigger Voltage	V _{GT}	V _D =12V R _L =1Ω	T _c =-40°C	-	-	-	V
			T _c =25°C	-	-	2.0	
Gate Trigger Current	I _{GT}	R _{GK} =20Ω	T _c =-40°C	-	-	-	mA
			T _c =25°C	-	-	350	
Gate Non-Trigger Voltage	V _{GD}	V _D =1/2 Rated	0.2	-	-	V	
Gate Non-Trigger Current	I _{GD}	T _c =115°C, R _{GK} =20Ω	10	-	-	mA	
Delay Time	t _d	V _D =1/2 Rated, T _c =25°C Gate Supply	-	-	3	μs	
Gate Turn-On Time	t _{gt}	(I _G =5A, t _r ≤1μs)	-	-	6	μs	
Critical Rate of Rise of Off-State Voltage	dv/dt	V _{DRM} =2/3 Rated T _j =115°C, V _G =-4V Exponential Rise R _{GK} =20Ω	350	-	-	V/μs	
Holding Current	I _H	T _c =25°C, R _{GK} =20Ω, R _L =2Ω	-	5	-	A	
Gate Turn-Off Voltage	V _{GQ}	I _T =1000A, V _{DRM} =2/3Rated dv/dt=350V/μs T _c =110°C	-	35	-	V	
Gate Turn-Off Current	I _{GQ}		-	250	-	A	
Storage Time (Note 2)	t _s	di _{RG} /dt=30A/μs I _T =1000A, I _G =250A dv/dt=350V/μs	-	-	12	μs	
Gate Turn-Off Time (Note 2)	t _{gq}	V _{DRM} =2/3 Rated, T _c =110°C	-	-	15	μs	
Thermal Resistance	R _{th(j-f)}	Junction to Fin	-	-	0.04	°C/W	

Note 2 SNUBBER : C=2μF, R=20Ω

