

C3200B-9213

C Plug Clamp Right Angle

50Ω

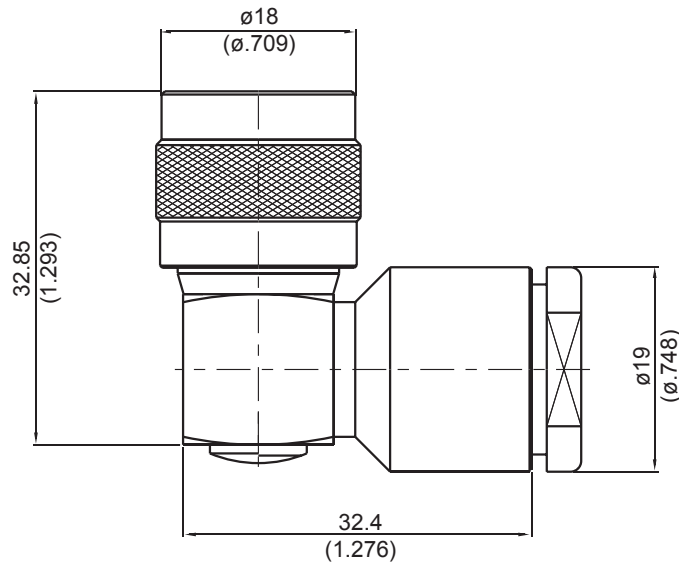

Parts	Material	Plating(Micro-inch)
Body	Brass	Tin-Zinc-Copper-Alloy 100 Over Copper 50
Nut	Brass	Tin-Zinc-Copper-Alloy 100 Over Copper 50
Nut Hex	Brass	Tin-Zinc-Copper-Alloy 100 Over Copper 50
Gasket	Silicone	
Braid Clamp	Brass	Tin-Zinc-Copper-Alloy 100 Over Copper 50
Contact Pin	Brass	Gold 5 Over Nickel 50 Over Copper 50
Spring	SK5	Tin-Zinc-Copper-Alloy 100 Over Copper 50
Washer	Brass	Tin-Zinc-Copper-Alloy 100 Over Copper 50
Insulator	Teflon	
Contact Body	Brass	Tin-Zinc-Copper-Alloy 100 Over Copper 50
Coupling Nut	Brass	Tin-Zinc-Copper-Alloy 100 Over Copper 50

Weight: 80.51 g

Suitable Cables: RG213

**This part number complies with RoHS.**

**Notice: JYEBAO reserves the right to make modifications deemed appropriate.**

## CABLE ASSEMBLY INSTRUCTION

C3200B-9213

JYE BAO CO., LTD.

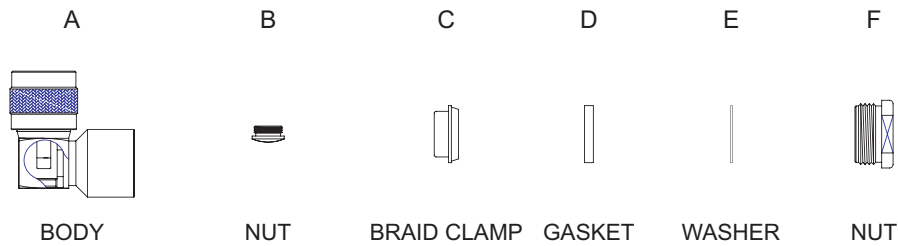

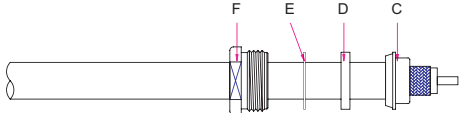
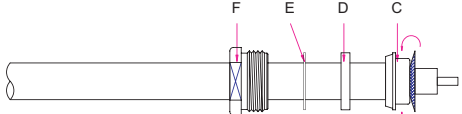
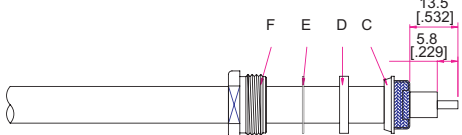

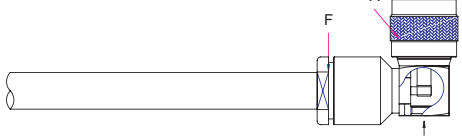



DIAGRAM	ASSEMBLY INSTRUCTION
	Step 1: STRIP AS SHOWN .
	Step 2: SLIDE BRAID CLAMP " C " ,GASKET " D " , WASHER " E " AND NUT " F " OVER CABLE .
	Step 3: WRAP THE BRAIDING OVER " C " .
	Step 4: STRIP AS SHOWN .
	Step 5: SCREW " F " ON THE CONNECTOR BODY " A " .
	Step 6: SLIDE CENTER CONDUCTOR ON THE CONTACT PIN OF CONNECTOR " A " AND SOLDER IN "Y"
	Step 7: FINALLY SCREW NUT " B " ON THE CONNECTOR BODY " A " .

This part number complies with RoHS.

Notice: JYEBAO reserves the right to make modifications deemed appropriate.