

- 1) Steckkraft mit Buchse
Mating force with jack
max. 15N
- 2) Abzugskraft mit Buchse
Unmating force with jack
ca. 10N

Kabelzuschnitt / Stripping dimension

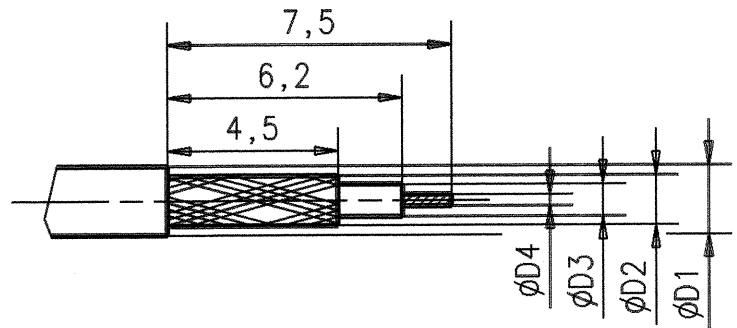



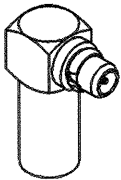

M2:1

M1:1



Fuer Kabel /
For cable

Gr.	TYPE TYP	$\phi D1$ MAX.	$\phi D2$ MAX.	$\phi D3$ MAX.	$\phi D4$ MAX.	$\phi D5$	$\phi D6$	$\phi D7$	$\phi D8$	Crimp  Aussen/out
1	RG 178-d	2.40	1.80	0.83	0.30	0.90	1.70	2.65	3.97	3.25
2										
3										
4										
5										

Gestellware	Ja	Nein	X	Werkstueckkanten:			Grossserienteil gefertigt nach Anlage	Ja
Verpackung	NR. :	/		DIN-6784			AGK 2677, AGK 2678, AGK 2679	
	Anzahl:	/		() Konstruktions-		Masse werden bei Abnahme	Werkstueckvolumen	Werkstueckoberflaeche
QP	TM	AP	LV	SP	masse	gesondert geprueft: DIN-406	V = mm ³	A = mm ²

IME CONNECTOR
SYSTEMS GMBH

ALLGEMEINTOL.
ISO 2768
mH

Masstab: 5:1

	Datum	Name
Bearb.	16.08.99	Schwör
Gepr.		
Norm		

Winkelstecker
Angle plug

2829.09.1420.01'

Rev.

Nr.	Zust.	Aenderung	Datum	Name
-----	-------	-----------	-------	------