

INCH-POUND  
MIL-PRF-39012/2H  
w/AMENDMENT 2  
4 May 2010  
SUPERSEDING  
MIL-PRF-39012/2H  
w/AMENDMENT 1  
17 April 2008

PERFORMANCE SPECIFICATION SHEET

CONNECTORS, PLUGS AND RECEPTACLES, ELECTRICAL, COAXIAL, RADIO FREQUENCY,  
(SERIES TNC (CABLED), FLANGE MOUNTED, SOCKET CONTACT, CLASS 2)

This specification is approved for use by all Departments  
and Agencies of the Department of Defense.

The requirements for acquiring the product described herein shall consist of  
this specification sheet and MIL-PRF-39012.

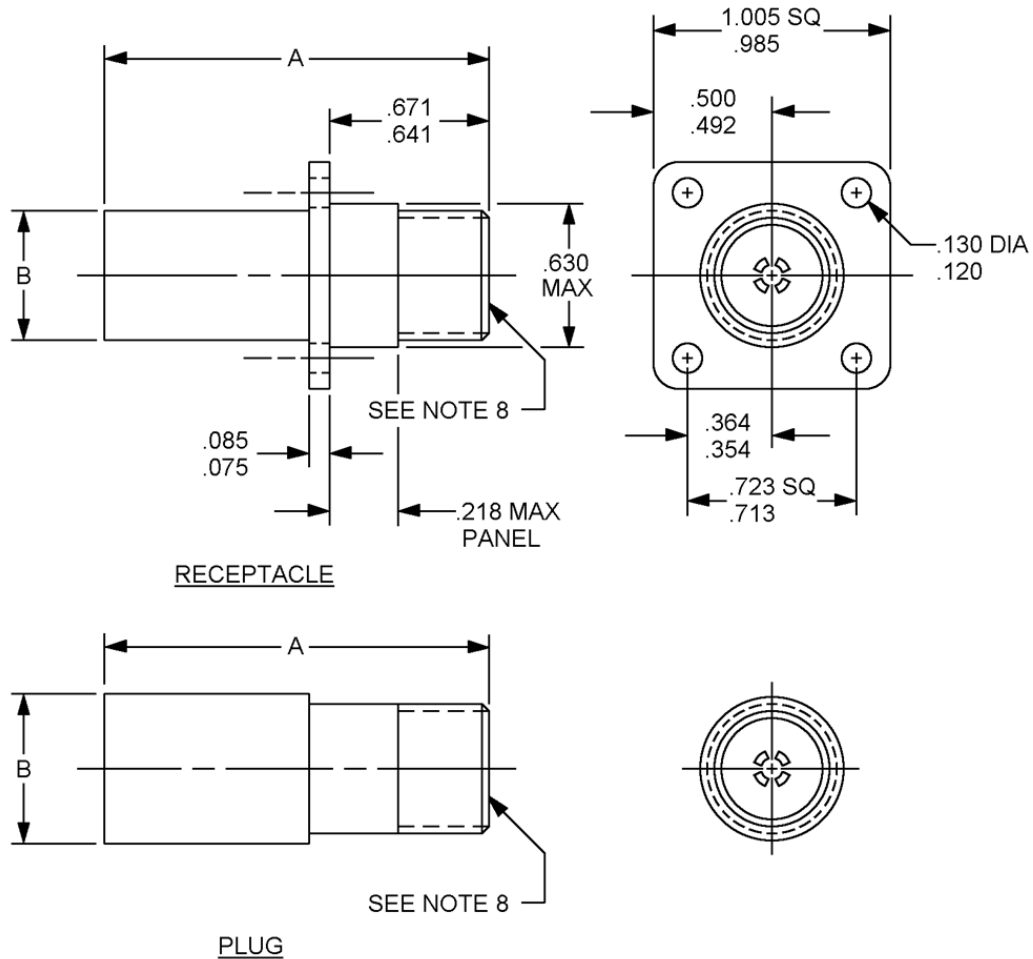

FIGURE 1. General configuration.

AMSC N/A

FSC 5935

MIL-PRF-39012/2H  
w/AMENDMENT 2

Inches	mm	Inches	mm	Inches	mm	Inches	mm
.075	1.91	.218	5.54	.500	12.70	.713	18.11
.086	2.16	.354	8.99	.630	16.00	.723	18.36
.120	3.05	.364	9.25	.641	16.28	.985	25.02
.130	3.30	.492	12.50	.671	17.04	1.005	25.53

NOTES:

1. Dimensions are in inches.
2. Metric equivalents are given for information only.
3. For dimension A, see tables I and II.
4. Dimensions A and B are the largest overall dimensions of the connector less the flange.
5. Wrench flats are to accommodate standard wrench opening in accordance with FED-STD-H28, appendix 10.
6. All undimensioned pictorial representations are for reference purposes only.
7. Dimension A defines the maximum length of the connector when assembled to the appropriate cable.
8. Series N, socket contact interface, in accordance with MIL-STD-348.

FIGURE 1. General configuration – Continued.

MIL-PRF-39012/2H  
w/AMENDMENT 2

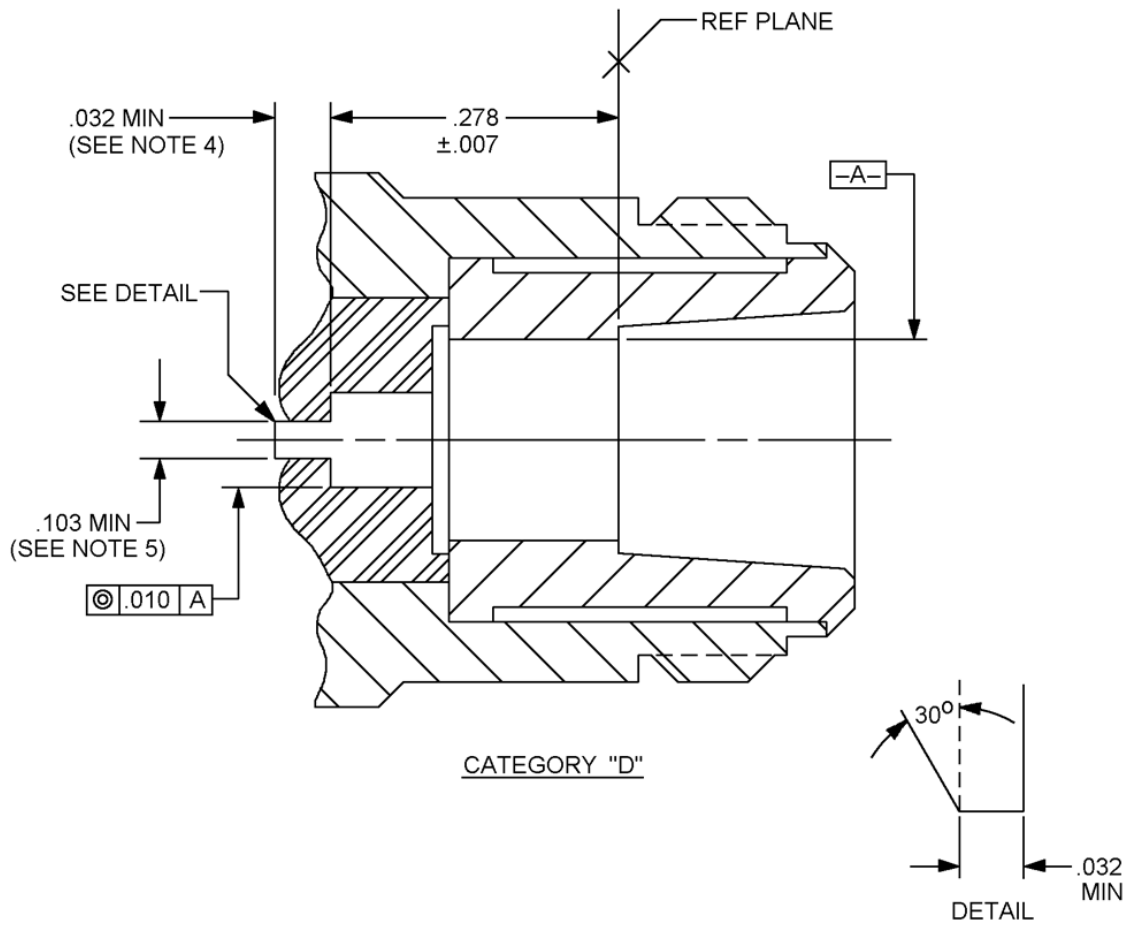

Inches	mm
.007	0.18
.010	0.25
.032	0.81
.103	2.62
.278	7.06

NOTES:

1. Dimensions are in inches.
2. Metric equivalents are given for information only.
3. Slot design optional.
4. Chamfer is optional.
5. Dimension shall meet connector performance requirements.

FIGURE 2. Category D captivation detail.

MIL-PRF-39012/2H  
w/AMENDMENT 2

TABLE I. Dash numbers, cross-reference, and dimensions.

Part or Identifying Number (PIN) M39012/02- <u>1</u> /	Type	Applicable cable <u>2</u> / M17/	Dimensions	Inches (millimeters) maximum #
Category A – Field serviceable (no special tools required) <u>3</u> /				
X101	Plug	Cable group VIII 112-RG304 <u>5</u> /	A B	1.672 (42.47) .781 (19.84)
X003	Plug	Cable group X 86-00001 <u>6</u> / 127-RG393 <u>5</u> /		
X131	Plug	Cable group XI 74-RG215 <u>5</u> / <u>7</u> /	A B	2.350 (59.69) .781 (19.84)
X134	Plug	Cable group XII 78-RG217 <u>5</u> /	A B	1.781 (44.84) .906 (23.01)
X104	Receptacle	Cable group VIII 112-RG304 <u>5</u> /	A B	1.672 (42.47) .750 (19.05)
X006	Receptacle	Cable group X 86-00001 <u>6</u> / 127-RG393 <u>5</u> /		

See notes at end of table.

MIL-PRF-39012/2H  
w/AMENDMENT 2

TABLE I. Dash numbers, cross-reference, and dimensions – Continued.

PIN M39012/02- <u>1</u> /	Type	Applicable cable <u>2</u> / M17/	Dimensions	Inches (millimeters) maximum #
Category A – Field serviceable (no special tools required) <u>3</u> /				
X132	Receptacle	Cable group XI 74-RG215 <u>5</u> / <u>7</u> /	A B	2.350 (59.69) .781 (19.84)
X133	Receptacle	Cable group XII 78-RG217 <u>5</u> /	A B	1.781 (44.84) .906 (23.01)
X050	Plug	220-00001	A B	2.350 (59.69) .906 (23.01)
X150		220-00002 <u>7</u> /		
X051		221-00001		
X151	Plug	221-00002 <u>7</u> /	A B	2.350 (59.69) .906 (23.01)
X052		222-00001		
X152		222-00002 <u>7</u> /		
X053		223-00001		
X153		223-00002 <u>7</u> /		
X054		224-00001		
X154		224-00002 <u>7</u> /		
X055		225-00001		
X155		225-00002 <u>7</u> /		
X056		226-00001		
X156		226-00002 <u>7</u> /		
X057		227-00001		
X157		227-00002 <u>7</u> /		
X058		228-00001		
X158		228-00002 <u>7</u> /		
X060	Receptacle	220-00001	A B	2.350 (59.69) .906 (23.01)
X160		220-00002 <u>7</u> /		
X061		221-00001		
X161		221-00002 <u>7</u> /		
X062		222-00001		
X162		222-00002 <u>7</u> /		
X063		223-00001		
X163		223-00002 <u>7</u> /		
X064		224-00001		
X164		224-00002 <u>7</u> /		
X065		225-00001		
X165		225-00002 <u>7</u> /		
X066		226-00001		
X166		226-00002 <u>7</u> /		
X067		227-00001		
X167		227-00002 <u>7</u> /		
X068		228-00001		
X168		228-00002 <u>7</u> /		

See notes at end of table.

MIL-PRF-39012/2H  
w/AMENDMENT 2

TABLE I. Dash numbers, cross-reference, and dimensions – Continued.

PIN M39012/02- <u>1/</u>	Type	Applicable cable <u>2/</u> M17/	Dimensions	Inches (millimeters) maximum #
Category C – Field replaceable (MIL-DTL-22520 crimp tool) See note next to cable group for applicable crimp die <u>3/ 8/</u>				
X019	Plug	Cable group VIII <u>9/</u> 112-RG304 <u>5/ 9/</u>	A B	1.938 (49.23) .781 (19.84)
X020	Plug	Cable group XA <u>10/</u> 65-RG165 <u>5/ 6/</u>		
X021	Plug	Cable group XB <u>10/</u> 86-00001 <u>6/</u> 127-RG393 <u>5/</u>		
X026	Plug	Cable group XC <u>10/</u> 62-RG144 <u>4/ 5/ 6/</u>		
X039	Plug	Cable group XD <u>10/</u> 77-RG216 <u>4/ 5/ 6/</u>		
X027	Receptacle	Cable group VIII <u>9/</u> 112-RG304 <u>5/</u>	A B	1.938 (49.23) .781 (19.84)
X028	Receptacle	Cable group XA <u>10/</u> 65-RG165 <u>5/ 6/</u>		
X029	Receptacle	Cable group XB <u>10/</u> 86-00001 <u>6/</u> 127-RG393 <u>5/</u>		

See notes at end of table.

MIL-PRF-39012/2H  
w/AMENDMENT 2

TABLE I. Dash numbers, cross-reference, and dimensions – Continued.

PIN M39012/02- <u>1/</u>	Type	Applicable cable <u>2/</u> M17/	Dimensions	Inches (millimeters) maximum #
Category C – Field replaceable (MIL-DTL-22520 crimp tool) See note next to cable for applicable crimp die <u>3/ 8/</u>				
X030	Receptacle	Cable group XD <u>10/</u> 77-RG216 <u>4/ 5/ 6/</u>	A B	1.938 (49.23) .781 (19.84)
X042	Receptacle	Cable group XC <u>10/</u> 62-RG144 <u>4/ 5/ 6/</u>		
Category D – Field replaceable – Defined piece parts <u>3/ 8/ 11/ 12/</u>				
X501	Plug	Cable group XB 127-RG393 <u>5/</u>	A B	1.656 (42.07) .750 (19.05)
X502	Plug	Cable group XA 65-RG165 <u>5/</u>		
X503	Plug	Cable group VIB 60-RG142 <u>6/</u> 128-RG400 <u>5/</u>	A B	1.593 (40.48) .750 (19.05)
X504	Plug	Cable group VIA 111-RG303 <u>5/</u>		
X511	Receptacle	Cable group XB 127-RG393 <u>5/</u>	A B	1.656 (42.07) .750 (19.05)
X512	Receptacle	Cable group XA 65-RG165 <u>5/</u>		

See notes at end of table.

MIL-PRF-39012/2H  
w/AMENDMENT 2

TABLE I. Dash numbers, cross-reference, and dimensions – Continued.

PIN M39012/02- <u>1/</u>	Type	Applicable cable <u>2/</u> M17/	Dimensions	Inches (millimeters) Maximum #
Category D – Field replaceable – Defined piece parts <u>3/ 8/ 11/ 12/</u>				
X513	Receptacle	Cable group VIB 60-RG142 <u>6/</u> 128-RG400 <u>5/</u>	A B	1.593 (40.48) .750 (19.05)
X514	Receptacle	Cable group VIA 111-RG303 <u>5/</u>		

- 1/ For cross-reference of dash number to superseded PIN or type designation, see table IV.
- 2/ The latest version of each cable shall be applicable.
- 3/ These connectors have captivated center contacts.
- 4/ Some of the cables in some cable groups are not 50 ohms; therefore, when attached to the specified connectors, VSWR, RF leakage and insertion loss are not applicable. Refer to MIL-PRF-39012 appendix for cable groupings.
- 5/ Cable to be used when performing tests requiring cable except as in 4/ and 6/.
- 6/ Cable to be used for the +200°C temperature cycling tests.
- 7/ Armored cable.
- 8/ These connectors are assembled using the applicable crimp tool, to the specified cables stripped as shown on figure 4.
- 9/ M22520/5-35 closure A or M22520/5-55 closure A.
- 10/ M22520/5-61.
- 11/ Complete connector assembly shall consist of a body, center contact, ferrule and assembly instructions.
- 12/ Not to be used in army equipment.
- # Dimensions are in inches. Metric equivalents are given for information only.
- X Denotes connector body plating material option. The only plating options allowable are Silver or Nickel over brass in accordance with MIL-PRF-39012. Only connectors of the same materials shall be mated to avoid dissimilar metal problems. **CAUTION: A NICKEL PLATED BODY IS NOT FOR USE IN APPLICATIONS WHERE PASSIVE INTERMODULATION GENERATION (PIM) MAY BE A CONCERN.** Silver is the preferred plating option.

MIL-PRF-39012/2H  
w/AMENDMENT 2

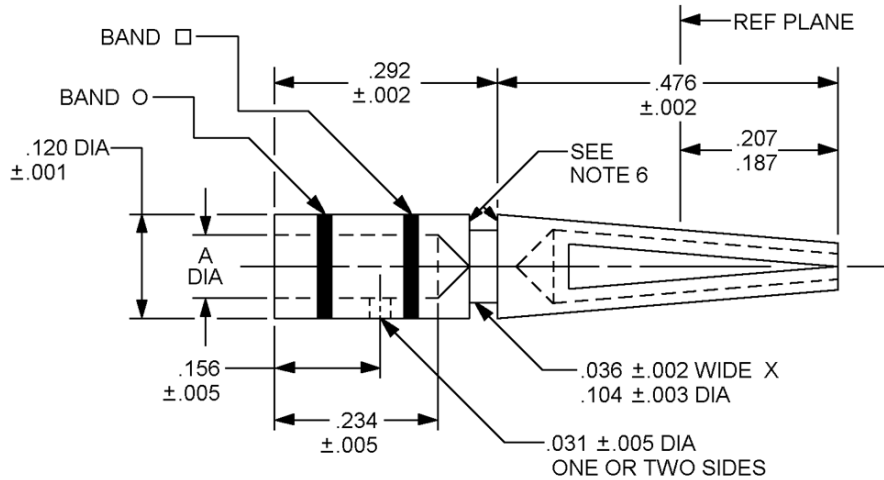

CENTER CONTACT

Inches	mm	Inches	mm	Inches	mm	Inches	mm
.001	0.03	.043	1.09	.207	5.26	.438	11.13
.002	0.05	.098	2.49	.220	5.59	.476	12.09
.003	0.08	.104	2.64	.234	5.94	.492	12.50
.005	0.13	.120	3.05	.245	6.22	.500	12.70
.015	0.38	.156	3.96	.250	6.35	.600	15.24
.031	0.79	.187	4.75	.292	7.42		
.036	0.91	.206	5.23	.418	10.62		

Dash no.	Contact no. <u>1/</u>	Dimension A	Basic crimp tool <u>2/</u> M22520/1	Crimp die or positioner M22520/1 <u>3/</u>	Crimp tensile minimum, pounds (N)	Color band □	Color band ○
X501 X502 X511 X512	2-10	.098 ± .002	-01	-13	60 (266.90)	Red	Brown
X503 X504 X513 X514	2-11	.043 + .001 - .002	-01	-13	20 (88.96)	Blue	Brown

1/ Contact numbers are for identification only.

2/ Class 2 tool may be used by OEM (see MIL-DTL-22520).

3/ Optional tool: M22520/5-01 with M22520/5-25 closure B die.

FIGURE 3. Contact and ferrule dimensions for category D only.

MIL-PRF-39012/2H  
w/AMENDMENT 2

NOTES:

1. Dimensions are in inches.
2. Metric equivalents are given for information only.
3. Contact material shall be copper beryllium. Connectors supplied with phosphor bronze contacts are acceptable for Government use until existing stock is purged. This elimination of the contact material option shall take effect 17 April 2009.
4. Crimp tensile test shall be in accordance with SAE-AS39029.
5. Copyright notice: All information disclosed in this specification sheet which is or may be copyrighted is reproduced herein with the express permission of the copyright owner.
6. Maximum break of .003 inch (0.08 mm).
7. Color bands shall be positioned such that no coloring material enters the inspection hole.

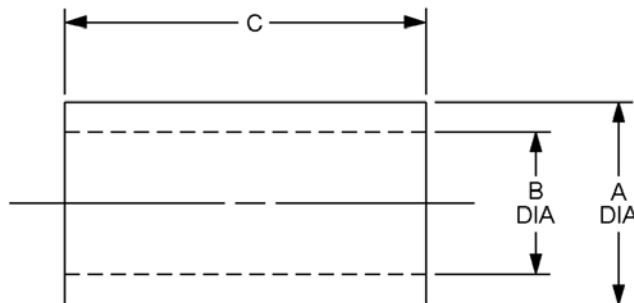

CRIMP FERRULE

Dash number	Ferrule number <u>1/</u>	A ± .003	B ± .003	C ± .015	Basic crimp Tool <u>2/</u>	Crimp die or positioner M22520/5
X501 X511	2-50	.492	.438	.600	M22520/5-01	25 Closure A or 61
X502 X512	2-51	.492	.418	.600		5, 11, 57 Closure A or 19 Closure B
X503 X513	2-52	.250	.220	.500		
X504 X514	2-53	.245	.206	.500		

1/ Ferrule numbers are for identification only.

2/ Class 2 tool may be used by OEM (see MIL-DTL-22520).

FIGURE 3. Contact and ferrule dimensions for category D only – Continued.

MIL-PRF-39012/2H  
w/AMENDMENT 2

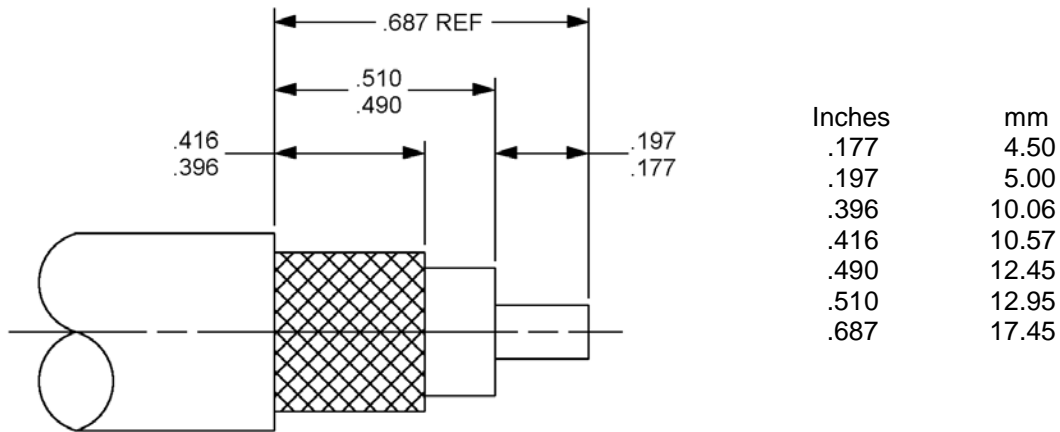

NOTES:

1. Dimensions are in inches.
2. Metric equivalents are given for information only.

FIGURE 4. Cable stripping dimensions for field replaceable connectors.

ENGINEERING DATA:

Nominal impedance: 50 ohms.

Frequency range: 0 to 11 GHz.

Voltage rating:

1,000 volts rms maximum working voltage at sea level.

250 volts rms maximum at 70,000 feet (4.437 kPa).

Temperature rating: -65°C to +165°C.

REQUIREMENTS:

Designs and configurations: See figures 1, 3, and 4.

Force to engage and disengage:

Longitudinal force: Not applicable.

Torque: 6 inch-pounds (.68 Nm) maximum.

Coupling proof torque: Not applicable.

Inspection conditions: Coupling torque: 6 to 10 inch-pounds (.68 to 1.13 Nm).

Mating characteristics: In accordance with MIL-STD-348 and figure 2.

MIL-PRF-39012/2H  
w/AMENDMENT 2

Center contact (socket):

Oversize test pin: .074 inch (1.88 mm) diameter, minimum (nonclosed entry contacts only).

Insertion depth: .125 inch (3.17 mm), minimum.

Number of insertions: 1.

Insertion force test: Steel test pin diameter .066 inch (1.68 mm), minimum.

Test pin finish: 16 micro inches (0.406  $\mu\text{m}$ ).

Insertion force: 2 pounds (8.90 N), maximum.

Withdrawal force test: Steel test pin diameter .063 inch (1.60 mm), maximum.

Withdrawal force: 2 ounces (.56 N), minimum.

Test pin finish: 16 microinches (0.406  $\mu\text{m}$ ).

Hermetic seal: Not applicable.

Leakage (pressurized connectors): Not applicable.

Insulation resistance: Method 302 of MIL-STD-202, test condition B. 5,000 megohms minimum.

Center contact retention: (Applicable to captivated-center-contact connectors only.) 15 pounds (66.72 N) minimum axial force for all cables except M17/128-RG400 and M17/60-RG142; 6 pounds (26.69 N) minimum for M17/128-RG400 and M17/60-RG142.

Corrosion (salt spray): Method 101 of MIL-STD-202, test condition B.

Voltage standing wave ratio (VSWR): From .5 to 11 GHz, or approximately 80 percent of upper cutoff frequency of the cable, whichever is lower; 1.30 maximum (1.45 max. to 11 GHz for -X503, -X504, -X513 and -X514).

Swept frequency VSWR test setup:

Item 6: VSWR shall be less than  $1.008 + .002 F$  (F in GHz).

Item 16: VSWR shall be less than  $1.008 + .002 F$  (F in GHz).

Second step of VSWR checkout procedure: VSWR shall be less than  $1.012 + .004 F$  (F in GHz).

Group B inspection: VSWR shall be less than  $1.024 + .007 F$  (F in GHz).

Qualification and group C inspection: VSWR shall not exceed 1.08.

Connector durability: 500 cycles minimum at 12 cycles/minute maximum. The connector shall meet the mating characteristics and force to engage and disengage requirements.

MIL-PRF-39012/2H  
w/AMENDMENT 2

Contact resistance: In milliohms maximum.

	<u>Initial</u>	<u>After environment</u>
Center contact	1.0	1.5
Outer contact (silver)	.2	Not applicable
Outer contact (nickel)	.4	Not applicable
Braid to body	.05	Not applicable

Dielectric withstanding voltage: Method 301 of MIL-STD-202. 2,500 volts rms minimum at sea level for connectors using other than M17/128-RG400 and M17/60-RG142; 1,500 volts rms minimum for connectors using M17/128-RG400 and M17/60-RG142.

Vibration, high frequency: Method 204 of MIL-STD-202, test condition B.

Shock: Method 213 of MIL-STD-202, test condition I.

Thermal shock: Method 107 of MIL-STD-202, test condition B, except test high temperature shall be +85°C. High temperature shall be +200°C for connectors using +200°C cables (see table I and III).

Moisture resistance: Method 106 of MIL-STD-202. No measurements at high humidity. Insulation resistance shall be at least 200 megohms within 5 minutes after removal from humidity.

Corona level:

Voltage: 500 volts rms minimum.

Altitude: 70,000 feet (4.437 kPa).

RF high potential withstanding voltage:

Voltage and frequency: 1,500 volts rms tested at a frequency from 5 to 7.5 MHz.

Leakage current: Not applicable.

Cable retention force:

Noncrimp assemblies: 75 pounds (333.62 N) minimum.

Crimp assemblies:

- 50 lbs minimum for cables .155 - .189 inch (3.94 mm – 4.80 mm) OD.
- 60 lbs minimum for cables .190 - .229 inch (4.83 mm – 5.82 mm) OD.
- 75 lbs minimum for cables .230 - .249 inch (5.84 mm – 6.32 mm) OD.
- 90 lbs minimum for cables .250 inch (6.35 mm) OD and larger.

MIL-PRF-39012/2H  
w/AMENDMENT 2

Coupling mechanism retention force: Not applicable.

RF leakage: -90 dB minimum, tested at a frequency between 2 and 3 GHz.

Insertion loss: .15 dB maximum at 10 GHz.

PIN: M39012/02- (dash number from table I or "B" number from table III).

TABLE II. Group qualification. 1/

Group	Submission and qualification of any of the following connectors <u>2/</u> M39012/	Qualifies the following connectors M39012/
I	02-X101 02-X003 02-X104 03-X101	02-X101 02-X003 02-X104 03-X101
II	02-X003 02-X006 03-X012	02-X003 02-X006 03-X012
III	02B0007 02B0008 02B0009 02B0012 02B0013 02B0015 02B0016 02B0017 03B0003 03B0004 03B0005 03B0008 03B0009	02B0007 02B0008 02B0009 02B0012 02B0013 02B0014 02B0015 02B0016 02B0017 02B0018 03B0003 03B0004 03B0005 03B0008 03B0009 03B0010 03B0011

See notes at end of table.

MIL-PRF-39012/2H  
w/AMENDMENT 2

TABLE II. Group qualification – Continued. 1/

Group	Submission and qualification of any of the following connectors <u>2/</u> M39012/	Qualifies the following connectors M39012/
IV	02-X019 02-X020 02-X021 02-X026 02-X027 02-X028 02-X029 02-X030 02-X034 03-X013 03-X014 03-X015 03-X016	02B0007 02B0008 02B0009 02B0012 02B0013 02B0014 02B0015 02B0016 02B0017 02B0018 02-X019 02-X020 02-X021 02-X026 02-X027 02-X028 02-X029 02-X030 02-X034 03B0003 03B0004 03B0005 03B0008 03B0009 03B0010 03B0011 03-X013 03-X014 03-X015 03-X016 03-X020 03-X021
V	02B0014 02B0018 03B0010 03B0011	02B0014 02B0018 03B0010 03B0011

See notes at end of table.

MIL-PRF-39012/2H  
w/AMENDMENT 2

TABLE II. Group qualification – Continued. 1/

Group	Submission and qualification of any of the following connectors <u>2/</u> M39012/	Qualifies the following connectors M39012/
VI	02-X019 02-X026 02-X027 02-X030 02-X039 02-X042 03-X020 03-X021	02B0014 02B0018 02-X026 02-X030 02-X039 02-X042 03B0010 03B0011 03-X020 03-X021
VII	02-X131 02-X132 02-X133	02-X131 02-X132 02-X133
VIII	02-X029 02B0036 02B0037 02B0038 02B0044	02-X029 02B0036 02B0037 02B0038 02B0044
IX	02B0035	02B0035
X	02-X501 02-X502 02-X511 02-X512	02-X501 02-X502 02-X503 02-X511 02-X512 02-X513
XI	02-X503 02-X513	02-X503 02-X513
XII	02-X504 02-X514	02-X504 02-X514

- 1/ If a connector manufacturer produces a connector which meets all the requirements for two or more connector PINs (within the same series), the manufacturer may receive qualification approval for two or more connector PINs by qualifying the one connector. It is not necessary that such connectors be in the same group. Each connector, however, must be marked with its own appropriate PIN. For group qualification, the connectors must be of similar design and be of the same materials and plating.
- 2/ For qualification retention, where more than one part is listed in a group in this column, data may be supplied on any of those parts in order to retain qualification for those parts in the corresponding right-hand column. The part does not necessarily have to be the part initially qualified.

MIL-PRF-39012/2H  
w/AMENDMENT 2

TABLE III. Category B – nonfield replaceable (special tools may be required). <sup>1/</sup>

**NOT FOR ARMY, NAVY OR AIR FORCE USE. FOR OEM USE ONLY**

PIN <sup>2/</sup> M39012/02B	Type	Applicable cable <sup>3/</sup> M17/	Dimensions	Inches (millimeters) Maximum <sup>9/</sup>
0007 <sup>4/</sup>	Plug	073-RG212 <sup>5/</sup> RG-222/U	A B	1.938 (49.23) .781 (19.84)
0008 <sup>4/</sup>	Plug	074-RG213 <sup>5/</sup>		
0009 <sup>4/</sup>	Plug	75-RG214 <sup>5/</sup>		
0012 <sup>4/</sup>	Plug	65-RG165 <sup>5/ 6/</sup>		
0013 <sup>4/</sup>	Plug	RG-225/U <sup>5/ 6/</sup>		
0014 <sup>4/</sup>	Plug	62-RG144 <sup>5/ 6/ 7/</sup> 6-RG11 <sup>7/</sup>		
0018 <sup>4/</sup>	Plug	77-RG216 <sup>5/ 7/</sup>		
0044 <sup>8/</sup>	Plug	2-RG006 <sup>5/ 7/</sup>		
0015 <sup>4/</sup>	Receptacle	073-RG212 <sup>5/</sup> RG-222/U	A B	1.938 (49.23) .750 (19.05)
0016 <sup>4/</sup>	Receptacle	074-RG213 <sup>5/</sup>		
0017 <sup>4/</sup>	Receptacle	75-RG214 <sup>5/</sup>		
0035 <sup>8/</sup>	Receptacle	65-RG165 <sup>5/ 6/</sup>		
0036 <sup>8/</sup>	Receptacle	6-RG11 <sup>7/</sup> 62-RG144 <sup>5/ 6/ 7/</sup>		
0037 <sup>8/</sup>	Receptacle	77-RG216 <sup>5/ 7/</sup>		
0038 <sup>8/</sup>	Receptacle	2-RG006 <sup>5/ 7/</sup>		

<sup>1/</sup> For maintenance replacements for category B, see table V.

<sup>2/</sup> For cross-reference of dash number to superseded PIN or type designation, see table IV.

<sup>3/</sup> The latest version of each cable shall be applicable.

<sup>4/</sup> Inactive for new design.

<sup>5/</sup> Cable to be used when performing tests requiring cable except as in <sup>6/</sup> and <sup>7/</sup>.

<sup>6/</sup> Cable to be used for the +200°C temperature cycling tests.

<sup>7/</sup> These are not 50-ohm cables; therefore, when attached to the specified connectors, VSWR, RF leakage, and insertion loss are not applicable.

<sup>8/</sup> These connectors have captivated center contacts.

<sup>9/</sup> Dimensions are in inches. Metric equivalents are given for information only.

MIL-PRF-39012/2H  
w/AMENDMENT 2

TABLE IV. Supersession data. 1/ 2/

Preferred PIN M39012/02 (except as otherwise specified in tables I or III)	Superseded PINs or superseded type designation
-0101	MS91233-20D, M39012/02-0001
-0003	MS91237-23F, MS91235-1186A, M39012/02-0002
-0104	MS91235-1MS91233-19E, M39012/02-0004
-0006	MS91237-22F, MS90536-1187A, M39012/02-0005
B0007	M23329/2-11, UG-1687/U, M39012/02-0011, UG-1691/U, M39012/02-0007
B0008	M23329/2-12, UG1688/U, M39012/02-0008
B0009	M23329/2-13, UG1689/U, M39012/02-0009
B0012	M23329/2-17, UG1692/U, M39012/02-0012
B0013	M23329/2-18, UG1693/U, M39012/02-0013
B0014	M23329/2-19, UG1694/U, M39012/02-0014
B0015	UG-1696/U, M39012/02-0015
B0016	UG-1697/U, M39012/02-0016
B0017	UG-1698/U, M39012/02-0017
B0018	UG-1818/U, M39012/02-0018
-0019	M39012/02-0023, M39012/02-0040
-0020	M39012/02-0024
-0021	M39012/02-0025
-0026	
-0027	M39012/02-0043
-0028	M39012/02-0041
-0029	M39012/02-0024
-0030	
-0131	UG-940C/U, M39012/02-0031
-0132	UG-935D/U, M39012/02-0032
-0133	
B0035	M39012/02-0035
B0036	M39012/02-0036
B0037	M39012/02-0037
B0038	M39012/02-0038
-0039	
-0042	
B0044	M39012/02-0044
-0501	
-0502	
-0503	
-0504	
-0511	M39012/02-0033
-0512	
-0513	
-0514	UG-1095/U

See notes at end of table.

MIL-PRF-39012/2H  
w/AMENDMENT 2

TABLE IV. Supersession data – Continued. 1/ 2/

1/The superseded PIN or the type designation is for reference only. Where a superseded PIN or type designation is not given, none was assigned or will be assigned. The PIN M39012/02-XXXX shall be used in all cases for marking and identifying the connector.

2/The basic type designation includes all letter versions of the specified number, e.g., UG-18/U includes UG-18A/U, UG-18B/U, etc

TABLE V. Maintenance replacements for category B.

Category B number <u>1/</u>	Category C dash number	Category A dash number	Category D dash number
PLUGS			
B0007	0019	0101	--
B0008	0020	0003	0502
B0009	0021	0003	0501
B0012	--	0003	--
B0013	--	0003	0501
B0014	0026	0003	--
B0044	--	0101	--
RECEPTACLES			
B0015	0027	0104	--
B0016	0028	0006	0512
B0017	0029	0006	0511
B0033	--	0006	0511
B0035	--	0006	--
B0036	0042	0006	--
B0037	0030	0006	--
B0038	--	0104	--

1/ Category B connectors are for original installation only. They will not be stocked or procured by the Government.

Amendment notations. The margins of this specification are marked with vertical lines to indicate modifications generated by this amendment. This was done as a convenience only and the Government assumes no liability whatsoever for any inaccuracies in these notations. Bidders and contractors are cautioned to evaluate the requirements of this document based on the entire content irrespective of the marginal notations.

MIL-PRF-39012/2H  
w/AMENDMENT 2

Referenced documents. In addition to MIL-PRF-39012, this document references the following:

FED-STD-H28  
MIL-STD-202  
MIL-STD-348  
MIL-DTL-22520  
SAE-AS39029

CONCLUDING MATERIAL

Custodians:

Army – CR  
Navy – EC  
Air Force – 85  
NASA – NA  
DLA - CC

Preparing activity:  
DLA – CC

(Project 5935-2009-070)

Review activities:

Army – AR, AT, EA, MI  
Navy – AS, MC, OS, SH  
Air Force – 19, 99

NOTE: The activities listed above were interested in this document as of the date of this document. Since organizations and responsibilities can change, you should verify the currency of the information above using the ASSIST Online database at <https://assist.daps.dla.mil>.