

- Differential Amplifier Inputs
- A-C Line Operation
- Capable of Triggering Several Types of Triacs
- Internal Active Elements of Saw-Tooth Generator for Proportional Control
- Wide Variety of Possible Connections of Input Section and of Output Section

**description**

The TL440 is a combination threshold detector and zero-crossing trigger, intended primarily for a-c power-control circuits. It allows a triac or SCR to be fired when the a-c input signal crosses through zero volts, thereby minimizing undesirable electromagnetic interference. In this manner, the load utilizes full cycles of line voltage as opposed to partial cycles typical with SCR phase-control power circuits.

The circuit includes a zero-voltage detector, a differential amplifier that may be used in conjunction with a resistance bridge to sense the parameter being controlled, the active elements of a saw-tooth generator, and an output section. Also included are resistors which may be used as a voltage divider for the reference side of the resistance bridge. An external sensor suitable for the application and an external potentiometer form the input side of the resistance bridge.

The TL440 can be used either as an on-off control with or without hysteresis, or as a proportional control with the use of the internal saw-tooth generator. Although the principal application of this device is in temperature control, it can be used for many power control applications such as a photosensitive control, voltage level sensor, a-c lamp flasher, small relay driver, or a miniature lamp driver.

The inhibit function prevents any output pulses from occurring when the applied voltage at the inhibit input is typically 1 volt or greater. Conversely, if the inhibit input is shorted to dc common, an output pulse will be obtained for each zero-crossing of the a-c power input waveform regardless of the sensor input conditions.

The TL440C is characterized for operation from 0°C to 70°C.

**schematic**

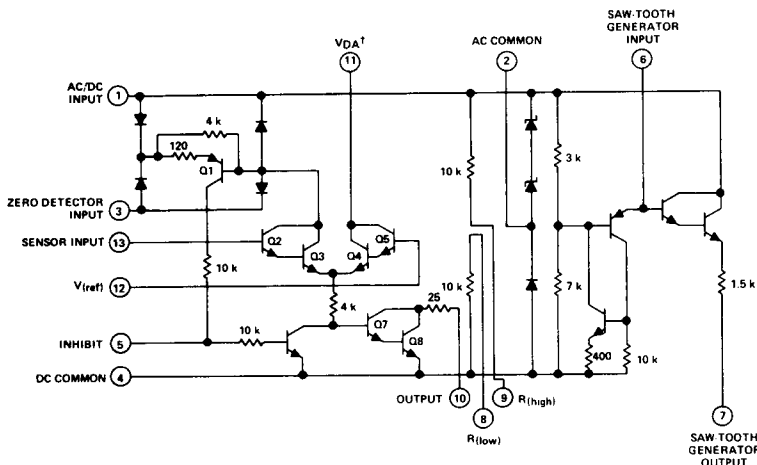

Resistor values shown are nominal and in ohms.

†Pin 11 is usually connected to the AC/DC input, pin 1, unless a control circuit requiring hysteresis is desired. See Figure 4.

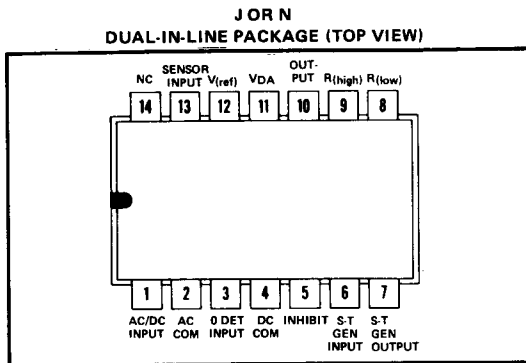

NC—No internal connection.

# TYPE TL440C

## ZERO-VOLTAGE SWITCH

### absolute maximum ratings over operating free-air temperature range (unless otherwise noted)

Voltage applied to AC/DC input (See Note 1)	15 V
Peak current into AC/DC input	40 mA
Peak current into zero-detector input	30 mA
Peak output sink current (See Note 2)	250 mA
Continuous total power dissipation at (or below) 70°C free-air temperature range	500 mW
Operating free-air temperature range	0°C to 70°C
Storage temperature range	-65°C to 150°C
Lead temperature 1/16 inch (1,6 mm) from case for 60 seconds: J package	300°C
Lead temperature 1/16 inch (1,6 mm) from case for 10 seconds: N package	260°C

- NOTES: 1. Voltage values are with respect to the dc common terminal unless otherwise specified.  
 2. This value applies for a maximum pulse width of 400  $\mu$ s and for a maximum duty cycle of 2%.

### recommended operating conditions

	MIN	NOM	MAX	UNIT
D-c voltage applied to AC/DC input (See Note 3)		12		V
Differential input voltage, $V_{13} - V_{12}$			$\pm 2$	V
Voltage at sensor or $V_{(ref)}$ input, $V_{13}$ or $V_{12}$		6		V
Peak output current (See Note 4)			200	mA
Output pulse width	100		400	$\mu$ s
Operating free-air temperature, $T_A$	0		70	°C

- NOTES: 3. This is the recommended d-c supply voltage when the voltage across pins 1 and 4 is not being maintained by charging an electrolytic capacitor from the line voltage. See typical application data.  
 4. This value applies for  $t_w \leq 400 \mu$ s, duty cycle  $\leq 2\%$ .

### electrical characteristics at 25°C free-air temperature (unless otherwise noted)

PARAMETER	TEST CONDITIONS	MIN	TYP	MAX	UNIT
Sensor input voltage hysteresis	Pin 11 connected to Pin 1		30		mV
Voltage required at inhibit input to inhibit output			1	3	V
Current into sensor input	$V_{13} = 6$ V, $V_{12} = 4$ V			5	$\mu$ A
Current into $V_{(ref)}$ input	$V_{12} = 6$ V, $V_{13} = 4$ V			5	$\mu$ A
Current into inhibit terminal required to inhibit output			20		$\mu$ A
Peak output current (pulsing)	$V_5 = 0$	75	100		mA
Output current (inhibited)	$V_{10} = 13.5$ V			1	$\mu$ A
Output pulse width into resistive load	25 k $\Omega$ connected to zero-detector input, 60-Hz power source		150		$\mu$ s
Average temperature coefficient of output pulse width (0°C to 70°C)			0.7		$\mu$ s/°C
Peak output voltage of saw-tooth generator	$V_1 = 12$ V		9		V
Voltage at AC/DC input(See Note 5)		9	11.5		V

- NOTE 5: This is the voltage across an electrolytic capacitor connected between pins 1 and 4 whose charge is maintained by the a-c line voltage. See Figures 1 and 3.



# TYPE TL440C ZERO-VOLTAGE SWITCH

## TYPICAL APPLICATION DATA

The circuit shown in Figure 3 provides proportional control of a heating system. With the exception of the saw-tooth generator, the circuit of Figure 3 functions the same as that of Figure 1. The sensor of Figure 3 has a negative temperature coefficient.

Transistors Q9 and Q10 are connected to function as an SCR in order to discharge external capacitor C2 very quickly. The time constant of the saw-tooth generator can be varied by changing either the external capacitor or the external resistor. However it is suggested that the capacitor be varied and not the resistor since too low a value of resistance would allow Q9 and Q10 to stay on continuously. The period of the saw-tooth generator is usually 10 to 100 times the period of the line voltage.

At the start of the saw-tooth waveform the base of Q1 is high and output pulses occur at pin 10. At the desired temperature a certain number of output pulses occur during each saw-tooth cycle as shown in Figure 2(a). At a slightly decreased temperature the resistance of the sensor increases, lowering the d-c potential of pin 13. This lowers the potential of the entire saw-tooth waveform as shown in Figure 2(b) which causes a few more output pulses to occur. At greatly decreased temperatures many more pulses occur each saw-tooth cycle as shown in Figure 2(c).

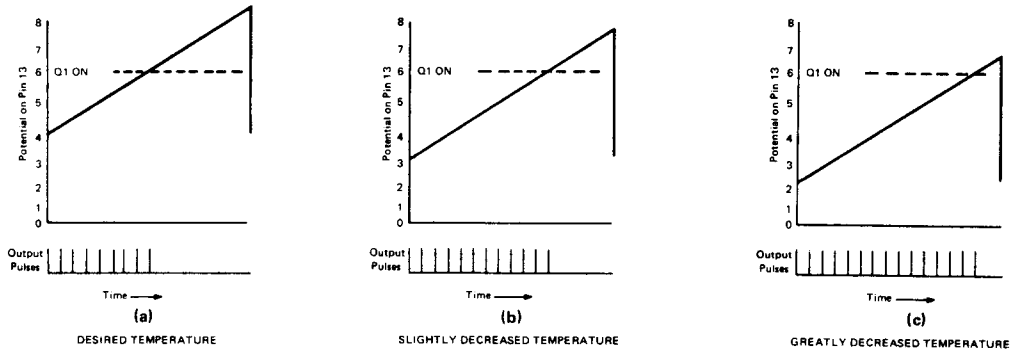

FIGURE 2

Similarly, increases in temperature cause proportionately fewer output pulses than the normal number of Figure 2(a). Thus the proportional control feature allows a smoother control of temperature in this application by always providing output pulses during some portion of the saw-tooth generator cycle as opposed to the "full on/full off" circuit of Figure 1.

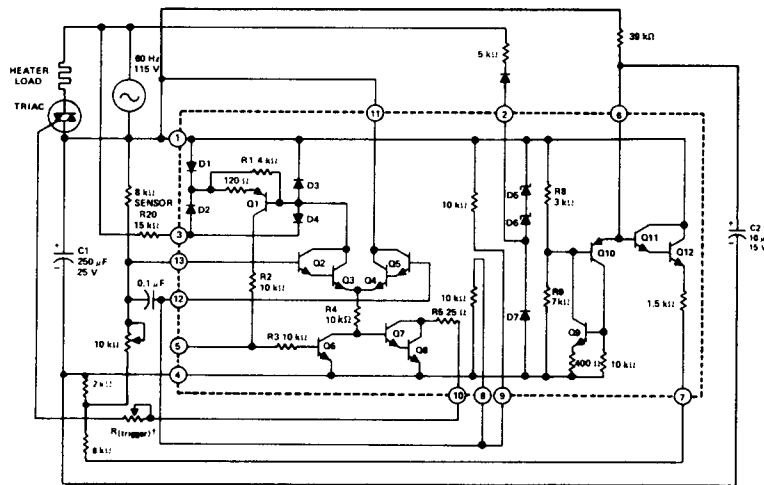
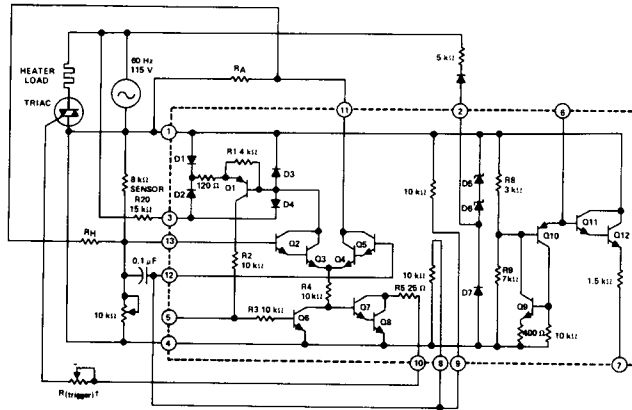

FIGURE 3—PROPORTIONAL HEATER CONTROL

<sup>†</sup> R<sub>(trigger)</sub> is adjusted so that the peak output is less than 200 mA.

## TYPICAL APPLICATION DATA

Hysteresis may be added to the TL440 by externally making the differential amplifier appear in Schmitt-trigger configuration. This is done by applying positive feedback from pin 11 to pin 13 through hysteresis resistors  $R_A$  and  $R_H$ . When the output is enabled, the voltage drop developed across resistor  $R_A$  is fed through  $R_H$  to the sensor input of the differential amplifier. This lowers the voltage at this point from the voltage level present when the output is inhibited. The resistance of the sensor must now decrease enough to overcome this additional ("hysteresis") voltage in order to inhibit the output.  $R_H$  should have a typical value close to the value of the sensor used. The value of  $R_A$ , which determines the amount of hysteresis, should be approximately one tenth the value of  $R_H$ . In Figure 4 the 10 k $\Omega$  potentiometer is adjusted to set the voltage at pin 13 to the level at which the output is enabled. When precise control is not needed, such a circuit eliminates the small "uncertainty range" observed in time-proportioning systems.



†  $R_{(trigger)}$  is adjusted so that the peak output is less than 200 mA.

FIGURE 4—ON-OFF HEATER CONTROL WITH HYSTERESIS ADDED

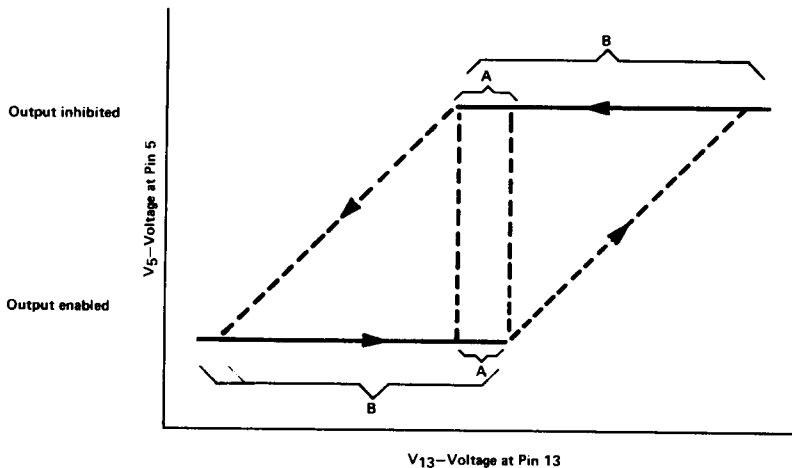

FIGURE 5—HYSTERESIS CURVE FOR FIGURE 4

A—Circuit without added hysteresis ( $\Delta V_{13} \approx 15$  to 20 mV residual hysteresis)

B—Circuit with added hysteresis ( $\Delta V_{13} \approx 200$  to 300 mV added hysteresis)

NOTE 1: Dotted lines represent discontinuous changes where the differential amplifier changes from inhibit to enable or vice-versa. Solid lines represent stable states (inhibit or enable) of the differential amplifier.