

FEATURES

- CLASS A OPERATION
- HIGH EFFICIENCY: $\eta_{ADD} \geq 39\%$ TYP
- BROADBAND CAPABILITY
- PACKAGE OPTIONS:
Chip
Hermetic Package
- PARTIALLY MATCHED INPUT FOR PACKAGED DEVICES
- PROVEN RELIABILITY

DESCRIPTION

The NE8500295 power GaAs FET covers the 3.5 to 8.5 GHz frequency range with three different Class A, 2 W partially matched devices. Each packaged device has an input lumped element matching network.

The NE8500200 is the six-cell recessed gate chip used in the "95" package. The device incorporates a Ti-Al gate structure, SiO₂ glassivation and plated heat sink technology.

SELECTION CHART

PART NUMBER	TYPICAL PERFORMANCE		
	P _{OUT} (dBm)	FREQUENCY RANGE (GHz)	GL (dB)
NE8500200	33.8 MIN	2.0 to 10	8.0 MIN
NE8500295-4	33.8 MIN	3.5 to 4.5	10.5 MIN
NE8500295-6	33.8 MIN	5.5 to 6.5	9.5 MIN
NE8500295-8	33.5 MIN	7.5 to 8.5	8.0 MIN

ELECTRICAL CHARACTERISTICS (T_C = 25°C)

PART NUMBER PACKAGE OUTLINE			NE8500200 ¹ 00 (CHIP)			NE8500295-4 95			NE8500295-6 95			NE8500295-8 95		
SYMBOLS	PARAMETERS AND CONDITIONS	UNITS	MIN	TYP	MAX	MIN	TYP	MAX	MIN	TYP	MAX	MIN	TYP	MAX
I _{DSS}	Saturated Drain Current V _{DS} = 2.5 V, V _{GS} = 0	V	mA	660		1650	660		1650	660		1650	660	1650
V _P	Pinch-off Voltage V _{DS} = 2.5 V, I _D = 8 mA	V	-3.0		-1.0	-3.0		-1.0	-3.0		-1.0	-3.0		-1.0
g _m	Transconductance V _{DS} = 2.5 V, I _D = I _{DSS}	mS		600			600			600			600	
BV _{DGO}	Drain-Gate Breakdown Voltage I _{GD} = 8 mA	V	18			18			18			18		
I _{GS}	Gate to Source Current, V _{DS} = 10 V, I _{DSQ} = 450 mA, P _{OUT} = P _{TEST}	mA	-2.4		2.4	-2.4		2.4	-2.4		2.4	-2.4		2.4
R _{TH}	Thermal Resistance (Channel-to-Case)	°C/W						15			15			15
P _{TEST} ²	Power Output at Test Point V _{DS} = 10 V, I _{DS} = 450 mA set P _{IN} = 27.0 dBm P _{IN} = 24.5 dBm P _{IN} = 25.5 dBm	dBm	33.8				33.8			33.8			33.5	
GL	Linear Gain V _{DS} = 10 V, I _{DS} = 450 mA	dB	8.0	9.0		10.5			9.5			8.0		
η_{ADD} ³	Power Added Efficiency at P _{TEST}	%		42			47			45			39	

Notes:

1. Six-cell chip: all cells are used. RF performance of the chip is determined by packaging 10 chips per wafer. Wafer rejection criteria for standard devices are 2 rejects per 10 samples.
2. This is a production test. Test frequencies are: -4 @ 4.2 GHz, -6 @ 6.5 GHz, -8 and NE8500200 @ 8.5 GHz.

$$3. \eta_{ADD} = \frac{P_{OUT} - P_{IN}}{V_{DS} \times I_D} \times 100\%$$

CAEL5023

NE85002 SERIES

ABSOLUTE MAXIMUM RATINGS $(T_C = 25^\circ\text{C})$

SYMBOLS	PARAMETERS	UNITS	RATINGS
V_{DS}	Drain to Source Voltage	V	15
V_{GD}	Gate to Drain	V	-18
V_{GS}	Gate to Source Voltage	V	-12
I_D	Drain Current	A	2.5
I_G	Gate Current	mA	13
T_{CH}	Channel Temperature	$^\circ\text{C}$	175
T_{STG}	Storage Temperature	$^\circ\text{C}$	-65 to +175
P_T	Total power Dissipation	W	13

RECOMMENDED OPERATING CONDITIONS

SYMBOLS	PARAMETERS	UNITS	MIN	TYP	MAX
V_{DS}	Drain to Source Voltage	V	9		10
T_C	Channel Temperature	$^\circ\text{C}$			130
G_{COMP}	Input Power	dB _{COMP}			3
R_g	Gate Resistance	k Ω		1	2

NE8500295-6 LARGE SIGNAL IMPEDANCES

FREQUENCY GHz	Z_{IN} Ω	Z_{OUT} Ω
5.90	13.16 - j44.75	11.48 - j21.52
6.20	22.77 - j59.68	16.16 - j25.02
6.40	149.70 - j73.98	23.44 - j40.36
6.50	43.58 - j56.13	12.87 - j11.86

Z_{IN} is the impedance of the input matching circuit as seen by the gate.
 Z_{OUT} is the impedance of the output matching circuit as seen by the drain.

TYPICAL PERFORMANCE CURVE $(T_C = 25^\circ\text{C})$

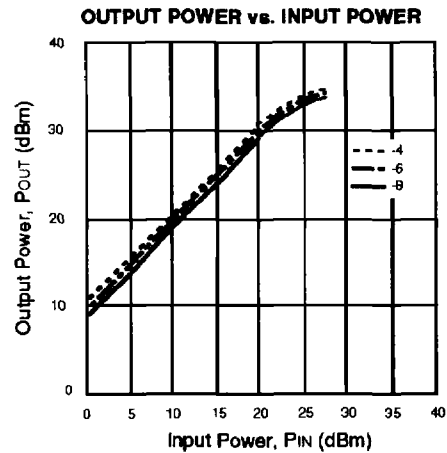
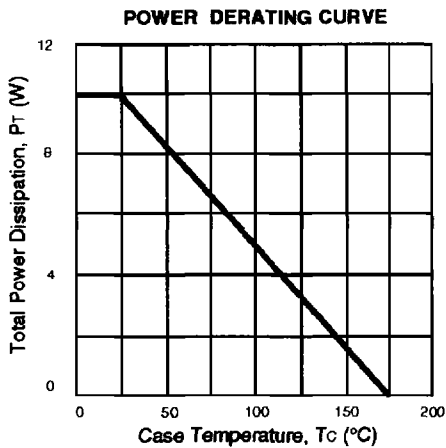

NE85002 SERIES

TYPICAL SCATTERING PARAMETERS (Tc = 25°C)

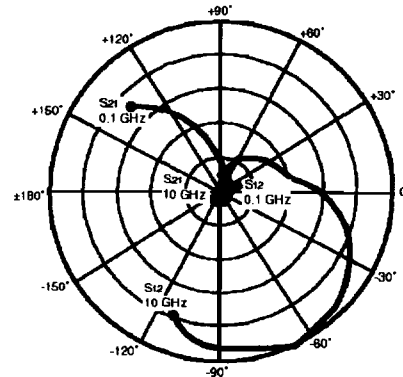
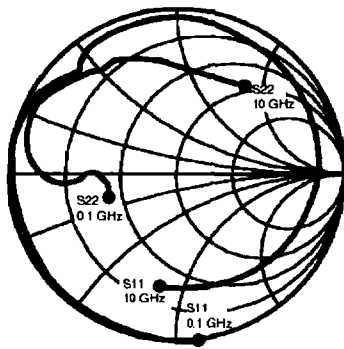

NE8500295-4

V_{ds} = 10 V, I_{ds} = 450 mA

FREQUENCY (GHz)	S ₁₁		S ₂₁		S ₁₂		S ₂₂		K	MAG ¹ (dB)
	MAG	ANG	MAG	ANG	MAG	ANG	MAG	ANG		
0.1	1.003	-81.900	14.230	135.700	0.009	-14.900	0.428	-158.600	-0.384	31.990
0.5	0.971	-161.600	3.768	90.400	0.010	26.000	0.414	-173.100	0.655	25.761
1.0	0.972	-179.600	2.006	69.100	0.012	19.700	0.429	-178.200	0.923	22.231
1.5	0.987	169.800	1.479	51.400	0.013	27.200	0.457	-178.700	0.521	20.560
2.0	0.976	160.100	1.255	34.300	0.017	27.600	0.479	179.500	0.804	18.682
2.5	0.965	150.700	1.205	15.900	0.018	18.300	0.514	177.400	0.976	18.257
3.0	0.927	145.700	1.149	-2.500	0.018	20.200	0.588	-176.700	1.876	12.657
3.5	0.886	139.600	1.343	-30.300	0.020	11.800	0.700	-176.000	1.464	14.232
4.0	0.843	134.633	1.486	-73.367	0.014	20.367	0.864	173.900	1.049	18.899
4.5	0.882	129.600	1.233	-126.500	0.021	76.600	0.931	153.400	-0.147	17.687
5.0	0.929	118.200	0.738	-166.200	0.037	54.400	0.838	137.500	-0.011	12.999
5.5	0.945	106.500	0.455	166.100	0.047	38.400	0.785	127.500	0.325	9.859
6.0	0.937	96.800	0.303	143.700	0.054	25.900	0.769	121.100	1.053	6.087
6.5	0.929	87.900	0.227	124.600	0.058	15.100	0.763	116.400	1.876	0.532
7.0	0.919	76.700	0.190	104.500	0.069	7.600	0.756	112.300	2.389	-2.190
7.5	0.905	60.100	0.186	80.200	0.086	0.300	0.725	107.100	2.654	-3.736
8.0	0.883	34.100	0.187	47.000	0.117	-18.200	0.676	96.600	2.868	-5.411
8.5	0.843	0.700	0.174	8.700	0.142	-44.800	0.629	80.500	3.794	-7.842
9.0	0.779	-29.300	0.144	-26.400	0.141	-74.800	0.623	66.100	6.295	-10.881
9.5	0.723	-59.300	0.124	-51.800	0.133	-95.500	0.647	55.900	8.799	-12.745
10.0	0.683	-97.000	0.116	-74.600	0.114	-110.500	0.661	52.500	11.714	-13.614

Note:

1. Gain Calculations:

$$MAG = \frac{|S_{21}|}{|S_{12}|} (K \pm \sqrt{K^2 - 1}). \text{ When } K \leq 1, \text{ MAG is undefined and MSG values are used. } MSG = \frac{|S_{21}|}{|S_{12}|}, K = \frac{1 + |\Delta|^2 - |S_{11}|^2 - |S_{22}|^2}{2 |S_{12}| |S_{21}|}, \Delta = S_{11} S_{22} - S_{21} S_{12}$$

NE85002 SERIES

TYPICAL SCATTERING PARAMETERS (Tc = 25°C)

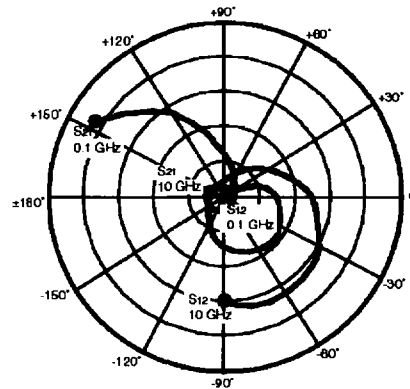
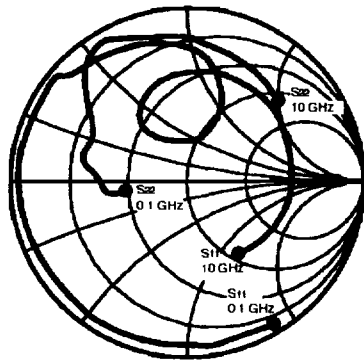

NE8500295-6

V_{DS} = 10 V, I_{DS} = 450 mA

FREQUENCY (GHz)	S ₁₁		S ₂₁		S ₁₂		S ₂₂		K	MAG ¹ (dB)
	MAG	ANG	MAG	ANG	MAG	ANG	MAG	ANG		
0.1	0.963	-59.200	16.698	149.400	0.003	29.700	0.373	-169.500	0.408	37.455
0.5	0.952	-149.100	5.714	97.600	0.016	22.800	0.463	-171.200	0.377	25.528
1.0	0.947	-173.800	3.033	74.200	0.017	20.000	0.485	-179.300	0.769	22.514
1.5	0.963	172.900	2.152	56.400	0.018	17.400	0.512	177.700	0.653	20.776
2.0	0.956	161.800	1.701	41.000	0.021	22.200	0.532	173.900	0.859	19.085
2.5	0.949	150.900	1.472	26.000	0.022	21.200	0.556	172.700	1.018	17.440
3.0	0.948	140.700	1.328	11.300	0.029	20.600	0.578	170.500	0.806	16.608
3.5	0.898	138.500	1.164	0.700	0.031	17.400	0.605	168.000	1.547	11.388
4.0	0.876	128.200	1.168	-13.300	0.036	11.000	0.607	163.200	1.554	10.727
4.5	0.847	116.000	1.278	-28.700	0.041	4.800	0.595	158.400	1.529	10.646
5.0	0.813	101.800	1.432	-47.900	0.048	-6.900	0.616	152.300	1.250	11.735
5.5	0.737	85.400	1.648	-71.000	0.054	-23.900	0.664	146.000	1.072	13.203
6.0	0.560	69.800	1.926	-99.800	0.057	-47.400	0.757	140.000	0.966	15.288
6.5	0.264	73.200	2.118	-137.200	0.046	-82.700	0.871	131.200	1.101	14.693
7.0	0.344	127.700	1.924	-176.300	0.023	-123.600	0.920	120.200	1.866	13.858
7.5	0.539	117.600	1.625	151.000	0.013	99.500	0.884	110.200	3.241	12.959
8.0	0.623	90.700	1.406	119.500	0.038	36.300	0.838	95.900	1.283	12.486
8.5	0.637	53.500	1.163	84.600	0.075	-1.900	0.779	74.700	1.035	10.759
9.0	0.610	16.000	0.868	52.600	0.096	-41.300	0.718	56.000	1.653	4.837
9.5	0.574	-16.900	0.676	25.900	0.099	-69.300	0.693	47.000	2.524	1.493
10.0	0.514	-55.800	0.561	-0.600	0.090	-88.500	0.673	43.200	3.931	-0.936

Note:

1. Gain Calculations:

$$MAG = \frac{|S_{21}|}{|S_{12}|} (K \pm \sqrt{K^2 - 1})$$

When $K \leq 1$, MAG is undefined and MSG values are used. $MSG = \frac{|S_{21}|}{|S_{12}|}$, $K = \frac{1 + |\Delta|^2 - |S_{11}|^2 - |S_{22}|^2}{2 |S_{12}| |S_{21}|}$, $\Delta = S_{11} S_{22} - S_{21} S_{12}$

MAG = Maximum Available Gain

MSG = Maximum Stable Gain

NE85002 SERIES

TYPICAL SCATTERING PARAMETERS (Tc = 25°C)

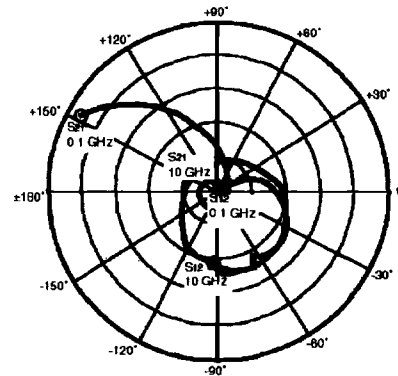
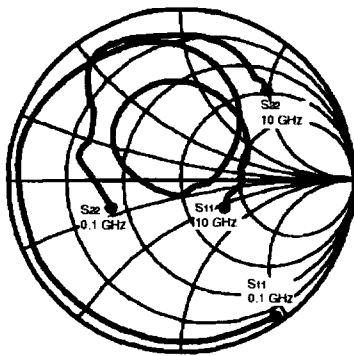

NE8500295-8

V_{DS} = 10 V, I_{DS} = 450 mA

FREQUENCY (GHz)	S ₁₁		S ₂₁		S ₁₂		S ₂₂		K	MAG ¹ (dB)
	MAG	ANG	MAG	ANG	MAG	ANG	MAG	ANG		
0.1	0.971	-54.800	17.977	150.900	0.004	35.400	0.427	-155.900	0.030	36.527
0.5	0.937	-146.300	6.354	98.200	0.016	24.000	0.464	-172.300	0.452	25.989
1.0	0.934	-174.000	3.391	74.500	0.018	22.300	0.492	-178.900	0.821	22.751
1.5	0.947	170.900	2.382	56.200	0.020	20.800	0.513	177.400	0.811	20.759
2.0	0.939	158.300	1.869	40.300	0.026	28.100	0.534	173.300	0.954	18.566
2.5	0.921	153.800	1.473	27.700	0.023	22.700	0.573	169.500	1.495	13.906
3.0	0.906	145.400	1.335	15.900	0.027	20.900	0.592	168.100	1.570	12.501
3.5	0.887	137.000	1.272	2.700	0.034	19.900	0.603	165.700	1.497	11.563
4.0	0.866	126.200	1.252	-11.100	0.041	10.200	0.602	160.300	1.423	10.984
4.5	0.836	113.900	1.343	-25.500	0.044	6.000	0.583	155.200	1.556	10.456
5.0	0.805	98.800	1.483	-43.600	0.056	-4.100	0.592	149.200	1.211	11.454
5.5	0.734	80.200	1.658	-64.900	0.065	-18.900	0.628	142.800	1.074	12.409
6.0	0.587	57.400	1.893	-90.600	0.073	-41.500	0.695	138.700	0.948	14.138
6.5	0.303	23.500	2.124	-122.700	0.075	-69.900	0.788	133.400	0.925	14.521
7.0	0.116	-152.800	2.078	-159.400	0.063	-101.500	0.874	125.700	1.015	14.431
7.5	0.394	158.700	1.824	167.500	0.042	-134.100	0.883	115.900	1.421	12.522
8.0	0.536	126.700	1.587	137.200	0.025	165.800	0.858	102.200	2.264	11.697
8.5	0.570	91.000	1.413	103.500	0.033	49.500	0.843	81.500	1.665	11.551
9.0	0.497	45.200	1.105	66.800	0.069	-26.200	0.773	59.800	1.861	6.692
9.5	0.354	3.800	0.787	38.600	0.067	-59.800	0.747	51.700	3.631	2.173
10.0	0.288	-34.500	0.622	17.000	0.068	-86.200	0.712	46.800	5.336	-0.631

Note:

1. Gain Calculations:

$$MAG = \frac{|S_{21}|}{|S_{12}|} (K \pm \sqrt{K^2 - 1}). \text{ When } K \leq 1, \text{ MAG is undefined and MSG values are used. } MSG = \frac{|S_{21}|}{|S_{12}|}, K = \frac{1 + |\Delta|^2 - |S_{11}|^2 - |S_{22}|^2}{2 |S_{12}| |S_{21}|}, \Delta = S_{11} S_{22} - S_{21} S_{12}$$

MAG = Maximum Available Gain

MSG = Maximum Stable Gain

RF TEST CIRCUIT

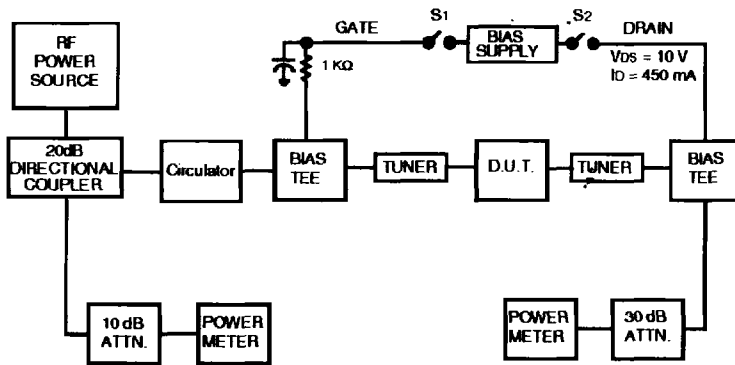

BIASING PROCEDURE

Turn on the power supply. Make sure its voltage is 0 V. Turn on S1 and S2. Apply $V_{GS} = -5$, then apply $V_{DS} = 10$ V. Decrease V_{GS} to obtain the required drain current, I_D . Apply the RF input and adjust the gate voltage to maintain the desired drain current. Do not exceed a gate current of 10 mA ($I_G = 10$ mA max).

OUTLINE DIMENSIONS AND HANDLING

PACKAGE OUTLINE 95
(Units in mm)

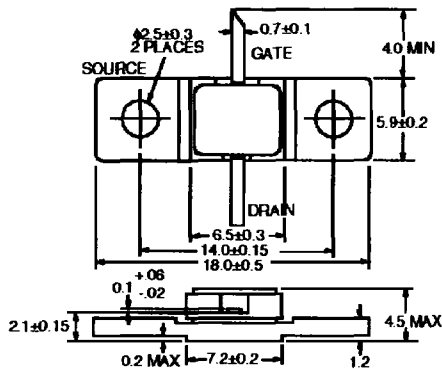

NE8500200 (CHIP)
(Units in μm)

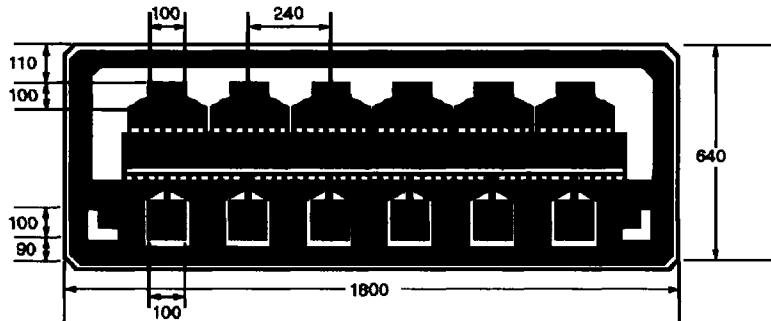

DIE ATTACHMENT

Die attach can be accomplished with either Au-Ge ($390 \pm 10^\circ\text{C}$) or Au-Sn ($290 \pm 10^\circ\text{C}$) preforms in a forming gas environment. Epoxy die attach is not recommended.

BONDING

Gate and drain bonding wires should be minimum length, semi-hard fold wire (3-8% elongation) 30 microns or less in diameter. The source should be connected with gold ribbon or mesh.

Bonding should be performed with a wedge tip that has a taper of approximately 15° . Die attach and bonding time should be kept to a minimum. As a general rule, the bonding operation should be kept within a $300^\circ\text{C} - 10$ minute curve. If longer periods are required, the temperature should be lowered.

PRECAUTIONS

The user must operate in a clean, dry environment. The chip channel is glassivated for mechanical protection only and does not preclude the necessity of a clean environment.

The bonding equipment should be periodically checked for sources of surge voltage and should be properly grounded at all times. All test and handling equipment should be grounded to minimize the possibilities of static discharge.

See AN-1001 Recommended Handling Procedure for Microwave Transistor & MMIC Chips for additional information.

EXCLUSIVE NORTH AMERICAN AGENT FOR NEC RF, MICROWAVE & OPTOELECTRONIC SEMICONDUCTORS

CEL CALIFORNIA EASTERN LABORATORIES • Headquarters • 4590 Patrick Henry Drive • Santa Clara, CA 95054-1817 • (408) 988-3500 • Telex 34-6393 • FAX (408) 988-0278
24-Hour Fax-On-Demand 800-390-3232 (U.S. and Canada only) • Internet <http://WWW.CEL.COM>

DATA SUBJECT TO CHANGE WITHOUT NOTICE

PRINTED IN USA ON RECYCLED PAPER -2/97