

## CRIMP TERMINATIONS FOR FLEXIBLE CABLE

For Cable Group Legend, see page 27

### STRAIGHT CRIMP PLUG — STANDARD CABLE

P.N.	Cable Group	Finish	Insulation	Impedance	Crimp Tool
132113	01	Gold	Teflon	50	A
132195	01A	Gold	Teflon	50	A
132234	01B	Gold	Teflon	50	A
132231	07B	Gold	Teflon	50	A
132298	07C	Gold	Teflon	50	L

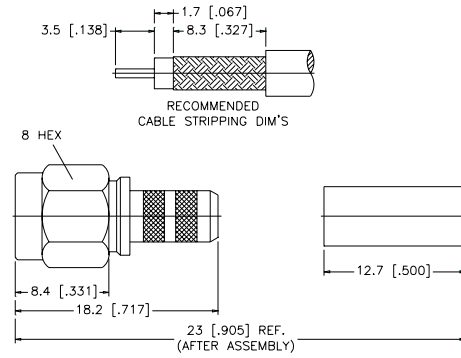

### STRAIGHT CRIMP PLUG — MINIATURE CABLE

P.N.	Cable Group	Finish	Insulation	Impedance	Crimp Tool
132114	05	Gold	Teflon	50	B
132114SS	05	Gold	Teflon	50	B
	STAINLESS STEEL				
132174	05	Gold	Teflon	50	B
	STAINLESS STEEL NUT				
132178	05A	Gold	Teflon	50	C
132193	14	Gold	Teflon	50	B
132242	16	Gold	Teflon	50	B

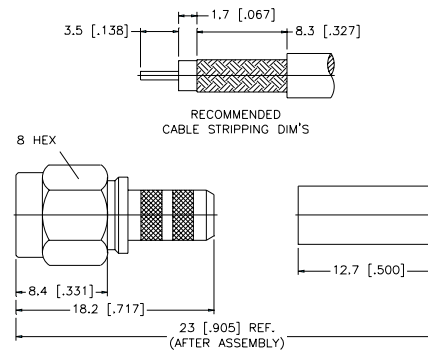

### RIGHT ANGLE CRIMP PLUG — STANDARD CABLE

P.N.	Cable Group	Finish	Insulation	Impedance	Crimp Tool
132122	01	Gold	Teflon	50	A
132122SS	01	Gold	Teflon	50	A
	STAINLESS STEEL				
132194	01A	Gold	Teflon	50	A
132235	01B	Gold	Teflon	50	A
132239	07B	Gold	Teflon	50	A
132299	07C	Gold	Teflon	50	L

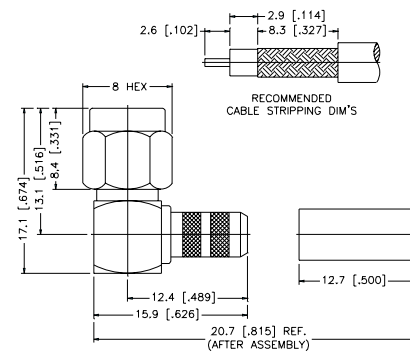

### RIGHT ANGLE CRIMP PLUG — MINIATURE CABLE

P.N.	Cable Group	Finish	Insulation	Impedance	Crimp Tool
132123	05	Gold	Teflon	50	B
132182	05A	Gold	Teflon	50	C
132173	14	Gold	Teflon	50	B
132272	16	Gold	Teflon	50	B

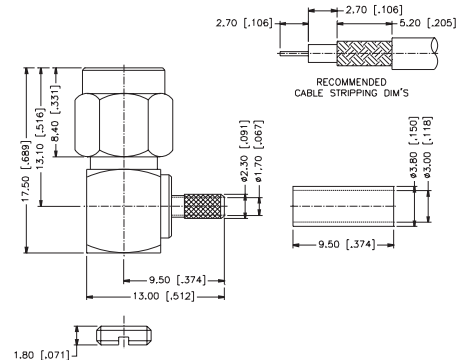

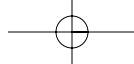

# CRIMP TERMINATIONS FOR FLEXIBLE CABLE

For Cable Group Legend, see page 27

## STRAIGHT CRIMP JACK — STANDARD & MINIATURE CABLE

P.N.	Cable Group	Finish	Insulation	Impedance	Crimp Tool
<b>STANDARD CABLE</b>					
132116	01	Gold	Teflon	50	A
132197	01A	Gold	Teflon	50	A
132236	01B	Gold	Teflon	50	A
132240	07B	Gold	Teflon	50	A
132332	07C	Gold	Teflon	50	L
<b>MINIATURE CABLE</b>					
132117	05	Gold	Teflon	50	B
132198	05A	Gold	Teflon	50	C
132229	05	Gold	Teflon	50	B
<b>SHORT BODY</b>					
132279	14	Gold	Teflon	50	B

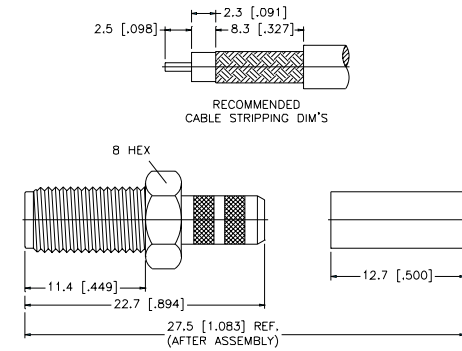

## BULKHEAD CRIMP JACK — STANDARD & MINIATURE CABLE

P.N.	Cable Group	Finish	Insulation	Impedance	Crimp Tool
<b>STANDARD CABLE</b>					
132118	01	Gold	Teflon	50	A
132191	01A	Gold	Teflon	50	A
132237	01B	Gold	Teflon	50	A
132241	07B	Gold	Teflon	50	A
132333	07C	Gold	Teflon	50	L
<b>MINIATURE CABLE</b>					
132119	05	Gold	Teflon	50	B
132176	05A	Gold	Teflon	50	C
132220	14	Gold	Teflon	50	B

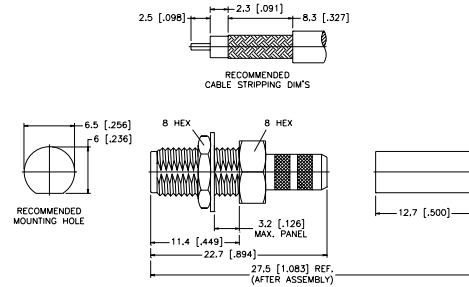

## BULKHEAD CRIMP JACK — O-RING SEAL — STANDARD & MINIATURE CABLE

P.N.	Cable Group	Finish	Insulation	Impedance	Crimp Tool
<b>STANDARD CABLE</b>					
132280	01	Gold	Teflon	50	A
132281	01A	Gold	Teflon	50	A
132282	01B	Gold	Teflon	50	A
132283	07B	Gold	Teflon	50	A
<b>MINIATURE CABLE</b>					
132284	05	Gold	Teflon	50	B
132285	05A	Gold	Teflon	50	C
132286	14	Gold	Teflon	50	B

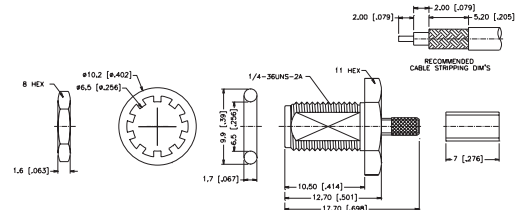
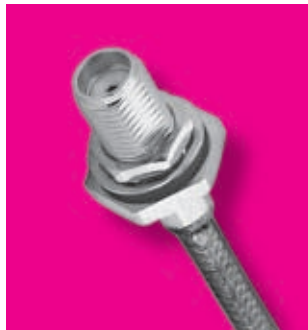

## RIGHT ANGLE BULKHEAD CRIMP JACK — STANDARD & MINIATURE CABLE

P.N.	Cable Group	Finish	Insulation	Impedance	Crimp Tool
132246	01	Gold	Teflon	50	A
132260	01A	Gold	Teflon	50	A
132245	05	Gold	Teflon	50	B
132259	05A	Gold	Teflon	50	C

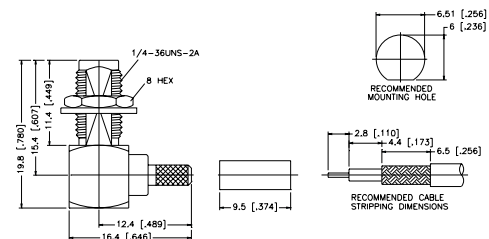
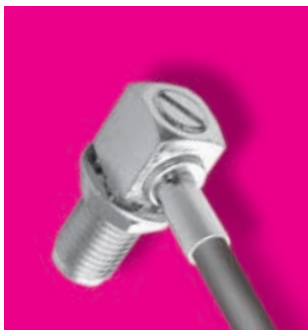

For Reverse Polarized connectors, add RP to standard part number. Contact Connex marketing for availability.  
 For Reverse Threaded connectors, add RT to standard part number. Contact Connex marketing for availability.  
 For Crimp Tool information, see page 183.

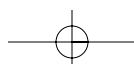

## CRIMP TERMINATIONS FOR FLEXIBLE CABLE

For Cable Group Legend, see page 27

## PANEL CRIMP JACK — STANDARD CABLE

P.N.	Cable Group	Finish	Insulation	Impedance	Crimp Tool
132120	01	Gold	Teflon	50	A
132254	01A	Gold	Teflon	50	A

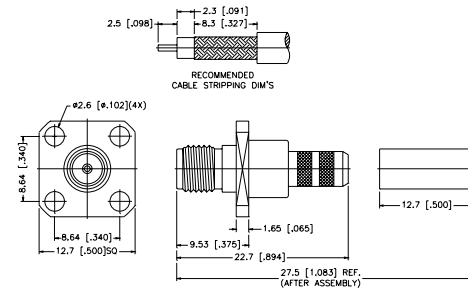

## PANEL CRIMP JACK — MINIATURE CABLE

P.N.	Cable Group	Finish	Insulation	Impedance	Crimp Tool
132121	05	Gold	Teflon	50	B
132199	05A	Gold	Teflon	50	C

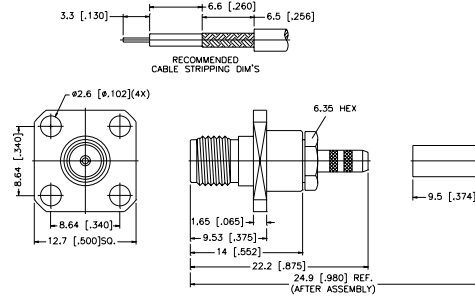

## RIGHT ANGLE PANEL JACK — 4-HOLE FLANGE

P.N.	Cable Group	Finish	Insulation	Impedance	Crimp Tool
132326	05	Gold	Teflon	50	B
132321	05A	Gold	Teflon	50	C
132327	14	Gold	Teflon	50	B

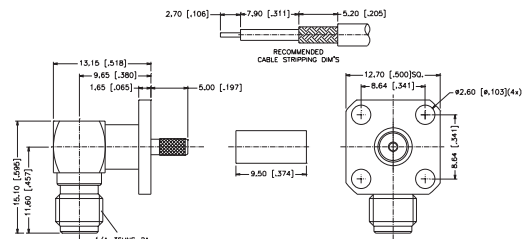

## RIGHT ANGLE PANEL JACK — 2-HOLE FLANGE

P.N.	Cable Group	Finish	Insulation	Impedance	Crimp Tool
132328	05	Gold	Teflon	50	B
132329	05A	Gold	Teflon	50	C
132330	14	Gold	Teflon	50	B

