



2111 Comprehensive Drive
Aurora, Illinois 60505
Phone: 630-851-4722
Fax: 630-851-5040
www.conwin.com

Description:

The Connor-Winfield's TX14 Series of Temperature Compensated Crystal Controlled Oscillators and Voltage Controlled Temperature Compensated Crystal Controlled Oscillators are designed for use in S3 Telecom Applications. Through the use of Analog Temperature Compensation, this device is capable of holding sub 1-ppm stabilities over the commercial or the industrial temperature ranges. All models will meet ± 4.6 ppm accuracies for twenty years. STRATUM 3 compliant models are available.

The TX14 series provides temperature stabilities in the range of ± 0.28 ppm to ± 2.50 ppm, over the commercial, extended commercial or the industrial temperature range.

The TX14 series is available with a CMOS or Clipped Sinewave output along with Tri-State Enable / Disable function or optional Electronic Frequency Tuning (VCTCXO). These oscillators provide outstanding phase noise characteristics that will meet the most stringent requirements.



Features:

- TCXO / VCTCXO
- CMOS Frequency Range: 1 to 52 MHz
- Clipped Sine Freq. Range: 6.4 to 52 MHz
- 3.3 Vdc or 5.0 Vdc Operation
- CMOS, or Clipped Sinewave Output
- Frequency Stabilities Available:
 - ± 0.28 ppm, ✓ STRATUM 3
 - ± 0.5 ppm, ± 1.0 ppm or ± 2.5 ppm
- Temperature Ranges Available:
 - 0 to 70°C, -20 to 70°C or -40 to 85°C
- Frequency Tolerance:
 - ± 4.60 ppm for 20 years.
- Low Jitter <1ps RMS
- Tri-State Enable/Disable Function or Voltage Control on Pin 1
- Hermetically Sealed 14 Pin DIP Package
- RoHS Compliant / Lead Free ✓ RoHS
- Recommended for New Designs

Package Outline

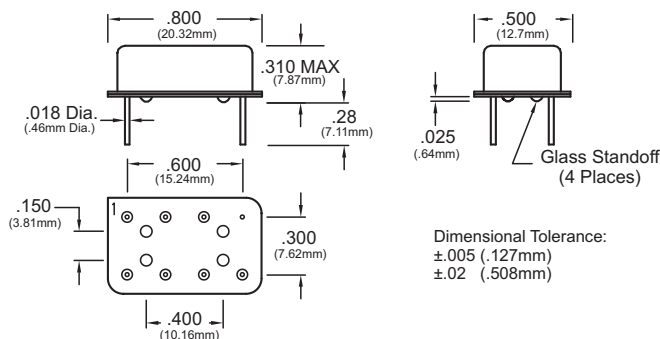

Marking Diagram

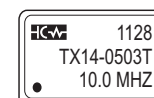

Pin Connections

- 1: Enable / Disable or Vc (optional)
- 7: Ground:
- 8: Output
- 14: Supply Voltage (Vcc)

Ordering Information

TX14-	05	0	3	T	-010.0M
Oscillator Type 14 Pin DIP TCXO or VCTCXO	Frequency Stability 28 = ± 0.28 ppm 05 = ± 0.50 ppm 10 = ± 1.00 ppm 25 = ± 2.50 ppm	Temperature Range 0 = 0 to 70°C 1 = -20 to 70°C 2 = -40 to 85°C	Supply Voltage Output Type 3 = 3.3 Vdc - LVCMOS 4 = 3.3 Vdc, Clipped Sine 5 = 5.0 Vdc, HCMOS 6 = 5.0 Vdc, Clipped Sine	Enable / Disable Voltage Control T = TCXO (Fixed Freq.) V = VCTCXO (Voltage Controlled)	Output Frequency Frequency Format -xxx.xM Min.* -xxx.xxxxxM Max*

*Amount of numbers after the decimal point.
M = MHz

Example Part Numbers:

TX14-0503T-010.0M = 14 Pin DIP package, ± 0.50 ppm, 0 to 70°C, 3.3 Vdc, LVCMOS Output, TCXO, Output Frequency 10.0 MHz

TX14-1025V-020.0M = 14 Pin DIP package, ± 1.00 ppm, -40 to 85°C, 5.0 Vdc, HCMOS Output, VCTCXO, 20.0 MHz



Bulletin **Tx343**
Page **1 of 4**
Revision **01**
Date **19 Jul 2013**



Absolute Maximum Ratings

Parameter		Minimum	Nominal	Maximum	Units	Notes
Storage Temperature		-55	-	125	°C	
Supply Voltage:	3.3 Vdc (Vcc)	-0.5	-	4.5	Vdc	
	5.0 Vdc (Vcc)	-0.5	-	7.0	Vdc	
Control Voltage (Vc)		-0.5	-	Vcc+0.5	Vdc	

Absolute Ratings: Stresses beyond those listed under "absolute maximum ratings" may cause permanent damage to the device. These are stress ratings only. The functional operation of the device at those or any other conditions beyond those indicated under "recommended operating conditions" is not implied. Exposure to conditions outside the "recommended operating conditions" for any extended period of time may adversely impact device reliability and result in failures not covered by warranty.

Operating Specifications for TX14-28xxx Series

Parameter		Minimum	Nominal	Maximum	Units	Notes
Frequency Range: (Fo)		1.0	-	40	MHz	
Frequency Calibration:		-1.0	-	1.0	ppm	1
Frequency Stability vs. Change in Temperature: (See Ordering Information)						✓ STRATUM 3
	Stability Code 28	-0.28	-	0.28	ppm	2
Holdover Stability:		-0.32	-	0.32	ppm	3
Frequency Stability vs. Load		-50	-	50	ppb	±5%
Frequency Stability vs. Voltage		-50	-	50	ppb	±5%
Aging / Life: (20 Years)		-3.0	-	3.0	ppm	
Aging / Day:(@25 °C)		-40	-	40	ppb/day	
Aging / Second:		-4.63E-13	-	4.63E-13		
Total Frequency Tolerance (20 Years)		-4.60	-	4.60	ppm	4

Operating Specifications for TX14-05xxx Series

Parameter		Minimum	Nominal	Maximum	Units	Notes
Frequency Range: (Fo)		1.0	-	40	MHz	
Frequency Calibration:		-1.0	-	1.0	ppm	1
Frequency Stability vs. Change in Temperature: (See Ordering Information)						
	Stability Code 05	-0.50	-	0.50	ppm	2
Frequency Stability vs. Load		-50	-	50	ppb	±5%
Frequency Stability vs. Voltage		-50	-	50	ppb	±5%
Aging / Life: (20 Years)		-3.0	-	3.0	ppm	
Total Frequency Tolerance (20 Years)		-4.60	-	4.60	ppm	4

Operating Specifications for TX14-10xxx Series

Parameter		Minimum	Nominal	Maximum	Units	Notes
Frequency Range: (Fo)		1.0	-	52	MHz	
Frequency Calibration:		-1.0	-	1.0	ppm	1
Frequency Stability vs. Change in Temperature: (See Ordering Information)						
	Stability Code 10	-1.00	-	1.00	ppm	2
Frequency Stability vs. Load		-50	-	50	ppb	±5%
Frequency Stability vs. Voltage		-50	-	50	ppb	±5%
Aging / Life: (20 Years)		-3.0	-	3.0	ppm	
Total Frequency Tolerance (20 Years)		-4.60	-	4.60	ppm	4

Operating Specifications for TX14-25xxx Series

Parameter		Minimum	Nominal	Maximum	Units	Notes
Frequency Range: (Fo)		1.0	-	52	MHz	
Frequency Calibration:		-1.0	-	1.0	ppm	1
Frequency Stability vs. Change in Temperature: (See Ordering Information)						
	Stability Code 25	-2.50	-	2.50	ppm	2
Frequency Stability vs. Load		-50	-	50	ppb	±5%
Frequency Stability vs. Voltage		-50	-	50	ppb	±5%
Aging / Life: (20 Years)		-3.0	-	3.0	ppm	
Total Frequency Tolerance (20 Years)		-4.60	-	4.60	ppm	4

Notes:

1. Initial calibration @ 25°C. Specifications at time of shipment after 48 hours of operation. For VCTCXO control voltage must be fixed.
2. Frequency stability vs. change in temperature. $[\pm(F_{max} - F_{min}) / (2 * F_0)]$.
3. Inclusive of frequency stability, supply voltage change (±1%), aging, for 24 hours.
4. Inclusive of calibration @ 25°C, frequency vs. change in temperature, change in supply voltage (±5%), load change (±5%), shock and vibration and 20 years aging.

Bulletin	Tx343
Page	2 of 4
Revision	01
Date	19 Jul 2013



Operating Temperature Ranges

Parameter	Minimum	Nominal	Maximum	Units	Notes
Operating Temperature Range: (See Ordering Information)					
Temperature Code 0	0	-	70	°C	
Temperature Code 1	-20	-	70	°C	
Temperature Code 2	-40	-	85	°C	

Operating Specifications

Parameter	Minimum	Nominal	Maximum	Units	Notes
Supply Voltage: (Vcc) (See Ordering Information)					
Supply Voltage Code 3, Code 4	3.13	3.30	3.47	Vdc	±5%
Supply Voltage Code 5, Code 6	4.75	5.00	5.25	Vdc	±5%
Supply Current: Vcc = Nominal Voltage	-	6	10	mA	
Static Temperature Hysteresis	-0.4	-	0.4	ppm	5
Jitter					
Period Jitter:	-	3	5	ps RMS	
Phase Jitter: (BW: 12 KHz to Fo/2)	-	0.5	1.0	ps RMS	
Typical SSB Phase Noise (Fo = 19.44 MHz)					
@ 10 Hz offset	-	-90	-85	dBC/Hz	
@ 100 Hz offset	-	-120	-115	dBC/Hz	
@ 1 KHz offset	-	-140	-135	dBC/Hz	
@ 10 KHz offset	-	-150	-145	dBC/Hz	
@ >100 KHz offset	-	-152	-150	dBC/Hz	
Start-Up Time:	-	-	1	ms	

CMOS Output Characteristics

Parameter	Minimum	Nominal	Maximum	Units	Notes
CMOS Output Code 3 or Code 5 (See Ordering Information)					
Load	-	15	-	pF	
Output Voltage:					
High (Voh)	90%Vcc	-	-	V	
Low (Vol)	-	-	10%Vcc	V	
Output Drive Current:					
Ioh	-	-	4	mA	
Iol	-4	-	-	mA	
Duty Cycle at 50% of Vcc	45	50	55	%	
Rise / Fall Time: 10% to 90%	-	-	8	ns	

Clipped Sinewave Output Characteristics

Parameter	Minimum	Nominal	Maximum	Units	Notes
Clipped Sinewave Output Code 4 or Code 6 (See Ordering Information) (Frequency Range for Clipped Sinewave is 6.4 to 52 MHz)					
Load	-	10K Ohm // 10pF	-	pF	AC Coupled
Output Voltage:					
≤ 40 MHz	1.00	-	-	V pk-pk	
> 40 MHz	0.80	-	-	V pk-pk	

Voltage Control Input Characteristics (Pin 1) Optional

Parameter	Minimum	Nominal	Maximum	Units	Notes
Control Voltage Range: (Vc) Voltage Control Code V (See Ordering Information)					
Vcc = 3.3 Vdc	0.30	1.65	3.00	V	
Vcc = 5.0 Vdc	0.5	2.5	4.5	V	
Frequency Pullability:	±10.0	-	-	ppm	6
Input Impedance	100K	-	-	Ohms	
Linearity	±5	-	-	%	
Slope	Positive Transfer Function				

Notes:

5. Frequency change after reciprocal temperature ramped over the operating range. Frequency measured before and after at 25°C
6. Referenced to Fo
7. (On page 4) Leave Pin 1 unconnected if enable / disable function is not required. When tri-stated, the output stage is disabled but the oscillator and compensation circuit are still active (current consumption ≤ 1mA).

Bulletin	Tx343
Page	3 of 4
Revision	01
Date	19 Jul 2013



Enable / Disable Function Characteristics (Pin 1)

Parameter	Minimum	Nominal	Maximum	Units	Notes
Enable / Disable Code T (See Ordering Information)					
Enable Voltage (High) or Open Circuit	70%Vcc	-	-	Vdc	7
Disable Voltage (Low) Output Tri-States	-	-	30%Vcc	Vdc	

Package Characteristics

TX14-Series Package 14 Pin DIP Hermetically Metal Package

Environmental Characteristics

Shock	500 G's 1ms, Halfsine, 3 shocks per direction, per MIL-STD 202G, Method 213B Test Condition D.
Sinusoidal Vibration	0.06" D.A. or 10G's Peak, 10 to 500 Hz, per MIL-STD-202G, Method 204D, Test Condition A.
Random Vibration	5.35 G's rms. 20 to 2000 Hz per MIL-STD-202G, Method 214, Test Condition 1A, 15 minutes each axis.
Moisture	10 cycles, 95% RH, Per MIL-STD-202G, Method 112.
Marking Permanency	Per MIL-STD-202G, Method 215J.
Solder Process	RoHS compliant, lead free. See solder profile on page 4.

CMOS Test Circuit

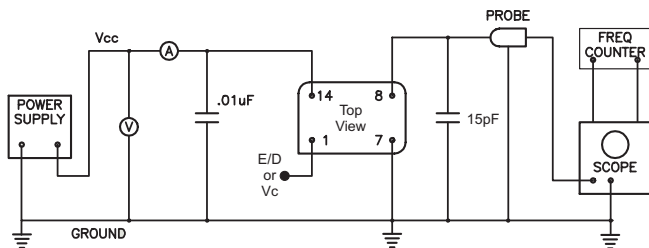

Clipped Sinewave Test Circuit

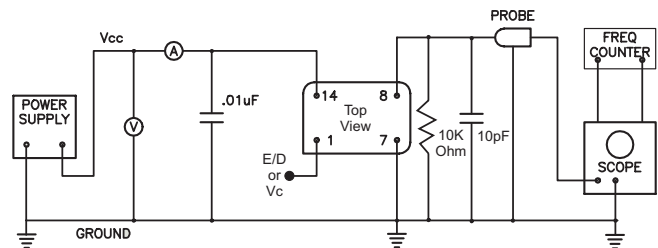

Attention: To achieve optimal frequency stability, and in some cases to meet the specification stated on this data sheet, it is required that the circuit connected to this TCXO output must have the equivalent input capacitance that is specified by the nominal load capacitance. Deviations from the nominal load capacitance will have a graduated effect on the stability of approximately 20 ppb per pF load difference.

CMOS Output Waveform

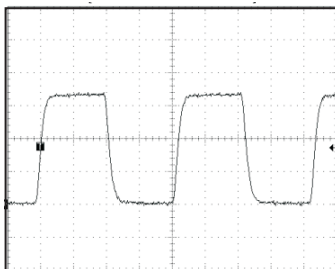

Clipped Sinewave Output Waveform

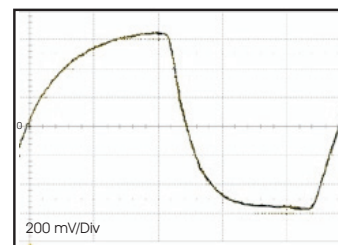

Phase Noise Plot

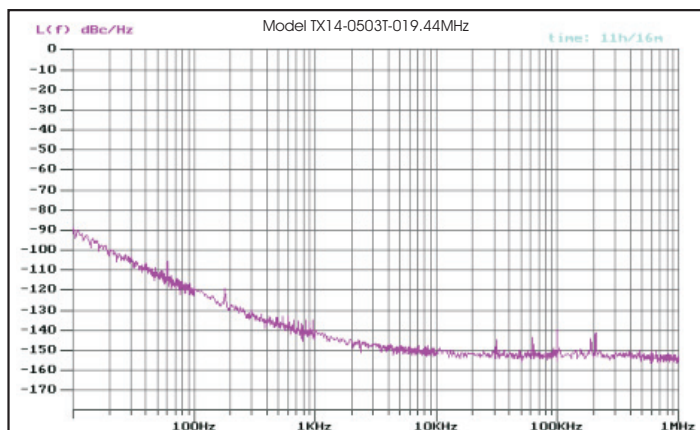

RoHS Solder Profile

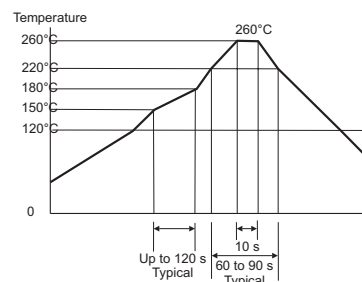

Meets IPC/JEDEC J-STD-020C

Bulletin	Tx343
Page	4 of 4
Revision	01
Date	19 Jul 2013