



PRODUCT OVERVIEW

The Marvell® Discovery™ II MV64360 system controller is the industry’s most powerful architecture for PowerPC® CPU-based systems. Building upon Marvell’s industry-standard Discovery platform, the Discovery II devices incorporate an innovative crossbar architecture, advanced communications peripherals and performance-tuned interfaces, setting new technology benchmarks for performance and integration. The Discovery II MV64360 system controllers high-performance crossbar switch architecture with any-to-any connectivity, allows system designers to develop high-performance, scalable systems. The Discovery II MV64360 device is the only system controller to support Symmetrical Multi-Processing in both 60x and MPX bus modes and offers an integrated SRAM block on the processor interface for low latency data storage. The Marvell Discovery II system controllers are ideally suited for a broad range of networking applications, including core routers/switches, wireless base stations and high-volume embedded applications such as storage networking and imaging.

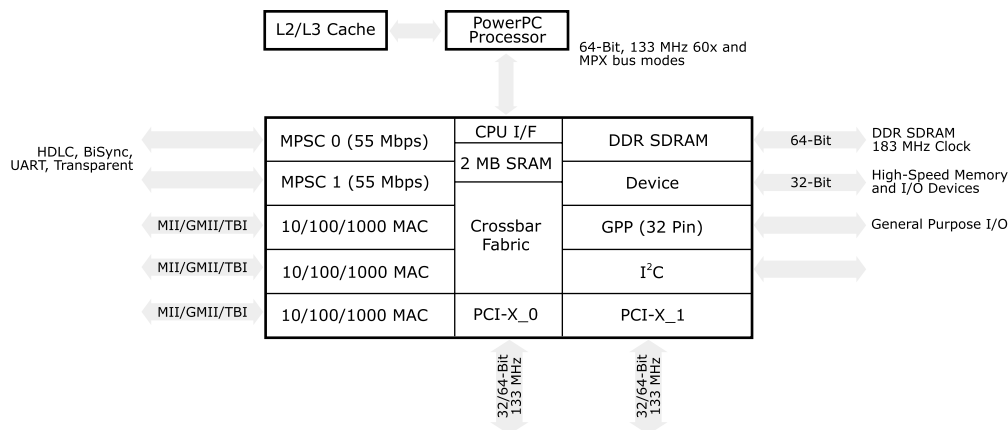

Fig 1. Discovery II (MV64360) PowerPC System Controller Block Diagram

FEATURES

- PowerPC CPU interface with up to 133 MHz CPU bus frequency
- Dual CPU SMP support — both 60x and MPX modes
- Crossbar switch architecture with up to 100 Gbps aggregate throughput
- On-board 2 MB SRAM block — cache coherent, parity protected — on CPU interface
- Dual 64-bit PCI/PCI-X interfaces with 66 MHz/133 MHz operation offering complete PCI-to-PCI (P2P) bridging for memory, I/O and configuration cycle
- Three Gigabit Ethernet (GbE) Media Access Controllers (MACs) with MII, GMII and TBI support
- 72-bit DDR SDRAM controller at a clock rate of 183 MHz (366 Mbps data rate)
- 32-bit high-speed device controller — up to 133 MHz clock rate
- Data integrity support between all interfaces

BENEFITS

- Supports all leading 64-bit PowerPC CPUs including Motorola® MPC750, 74xx and IBM 750Cxe, 750FX
- Only system controller to support SMP in both 60x and MPX bus modes. Enables the highest performing PowerPC subsystems
- Provide wire-speed performance between controller blocks to enable concurrent, non-blocking connectivity
- Low latency descriptor and packet header storage for CPU and all peripherals
- Preserve legacy PCI investment and provide easy migration to future PCI-X based platforms, more than 16 Gbps aggregate throughput
- Support Gigabit to the desktop initiatives; enable greater data throughput
- Supports cost-effective, high bandwidth DDR SDRAM memory with full ECC protection
- Enables high-throughput connectivity to SyncBurst SRAM, ASICs and other system peripherals
- Provides ECC support on DDR SDRAM, parity support on internal SRAM, CPU, PCI, and device bus to ensure reliable data transfers

FEATURES

- Integrated system and communications peripherals
- Development platforms with widely used PowerPC CPUs featuring Wind River® VxWorks® and Linux board support packages
- Software compatible with leading Marvell system controllers

BENEFITS

- Reduce system chip counts, lower cost and provide optimized performance
- Speed hardware and software development time, out-of-the-box operability
- Protects software investment, speeds time-to-market and reduces development risk

APPLICATIONS

The Marvell Discovery II system controller is ideal for PowerPC CPU-based subsystems in a broad range of applications. Its superior integration and flexibility allows system designers to build scalable networking and communications systems such as routers and switches at varying price/performance points.

The high-performance input and output (I/O) capabilities of the Discovery II device include dual PCI/PCI-X, three GbE MACs and dual multi-protocol serial controllers (MPSC) to support a wide range of applications. The dual PCI-X interfaces can be used to connect to GbE NICs, iSCSI adapters, Fiber Channel adapters, etc. Its multiple GbE ports are ideal for redundant backplane connectivity and remote management.

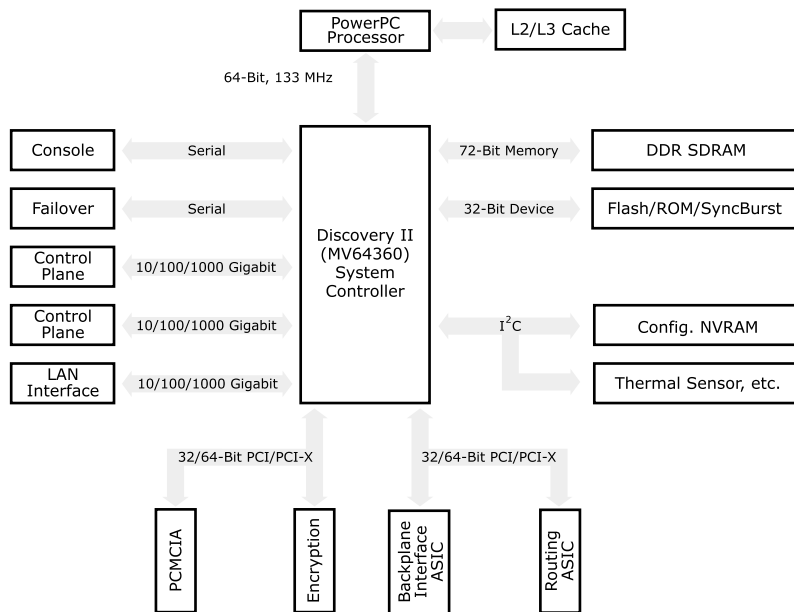

Fig 2. Discovery II (MV64360) PowerPC System Solution

THE MARVELL ADVANTAGE: The Marvell Discovery II PowerPC system controller comes with a complete set of hardware and software development tools to assist network hardware engineers with product evaluation. Marvell’s worldwide field applications engineers collaborate closely with network equipment vendors to develop and deliver new competitive products to market on time. Marvell utilizes recognized world-leading semiconductor foundry and packaging services to reliably deliver high-volume and low cost total solutions.

For more information, visit our website at www.marvell.com.



Marvell Semiconductor, Inc.
700 First Avenue
Sunnyvale, CA 94089
Phone 408.222.2500
www.marvell.com

©2002 Marvell International Ltd. All rights reserved. Marvell, the Marvell logo, Moving Forward Faster, Alaska, the Galileo logo, and GalNet are registered trademarks of Marvell. Discovery, Fastwriter, Galileo Technology, GalTis, Horizon, Libertas, Prestera, and Virtual Cable Tester are trademarks of Marvell. All other trademarks are the property of their respective owners.

100330-001 05/02