

Document No.	853-1272
ECN No.	93196
Date of Issue	May 5, 1988
Status	Product Specification
Data Communication Products	

AM26LS31

Quad high-speed differential line driver

DESCRIPTION

The AM26LS31 is a quad differential line driver, designed for digital data transmission over balanced lines. The AM26LS31 meets all the requirements of EIA standard RS-422 and Federal standard 1020. It is designed to provide unipolar differential drive to twisted-pair or parallel-wire transmission lines. The circuit provides an enable and disable function common to all four drivers. The AM26LS31 features 3-State outputs and logical ORed complementary enable inputs. The inputs are all LS compatible and are all one unit load.

The AM26LS31 is constructed using advanced Low Power Schottky processing.

FEATURES

- Output skew of 2.0ns typical
 - Input to output delay: 12ns
 - Operation from single +5V
 - 16-pin DIP and SO packages
 - Four line drivers in one package
 - Output short-circuit protection
 - Complementary outputs
 - Meets EIA standard RS-422
 - High output drive capability for 100Ω terminated transmission lines
 - Available in military and commercial temperature range
 - Advanced low power Schottky processing
 - Outputs won't load line when $V_{CC} = 0V$
- ### APPLICATIONS
- Data communications equipment
 - Computer peripherals
 - Workstations
 - Automatic test equipment

ORDERING INFORMATION

DESCRIPTION	TEMPERATURE RANGE	ORDER CODE
16-Pin Plastic DIP	0°C to +70°C	AM26LS31CN
16-Pin SO	0°C to +70°C	AM26LS31CD
16-Pin Plastic DIP	-40°C to +85°C	AM26LS31IN
16-Pin SO	-40°C to +85°C	AM26LS31ID
16-Pin Plastic DIP	-55°C to +125°C	AM26LS31MN

PIN CONFIGURATION

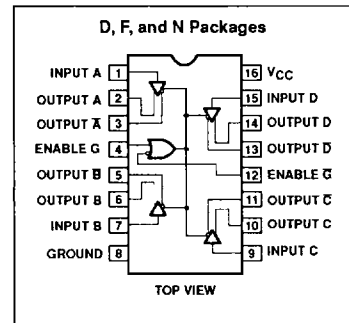

FUNCTION TABLE (Each Driver)

INPUT	ENABLES		OUTPUTS	
A	G	\bar{G}	A	\bar{A}
H	H	X	H	L
L	H	X	L	H
H	X	L	H	L
L	X	L	L	H
X	L	H	Z	Z

NOTES:

H = High level
 L = Low level
 X = Irrelevant
 Z = High-impedance (OFF)

Quad high-speed differential line driver

AM26LS31

DC AND AC ELECTRICAL CHARACTERISTICS $V_{CC} = 5V \pm 10\%$, $T_A = -55$ to $+125^\circ\text{C}$ for AM26LS31MF and AM26LS31MN;
 $V_{CC} = 5V \pm 5\%$, $T_A = -40$ to $+85^\circ\text{C}$ for AM26LS31IN and AM26LS31ID;
 $V_{CC} = 5V \pm 5\%$, $T_A = 0$ to $+70^\circ\text{C}$ for AM26LS31CN and AM26LS31CD,
 unless otherwise specified.

SYMBOL	PARAMETER	TEST CONDITIONS	LIMITS			UNIT
			Min	Typ ¹	Max	
V_{OH}	Output High voltage	$V_{CC} = \text{Min.}$, $I_{OH} = -20\text{mA}$	2.5	3.0		V
V_{OL}	Output Low voltage	$V_{CC} = \text{Min.}$, $I_{OL} = 20\text{mA}$		0.3	0.5	V
V_{IH}	Input High voltage	$V_{CC} = \text{Min.}$	2.0			V
V_{IL}	Input Low voltage	$V_{CC} = \text{Max.}$			0.8	V
I_{IL}	Input Low current	$V_{CC} = \text{Max.}$, $V_{IN} = 0.4\text{V}$		-0.26	-0.36	mA
I_{IH}	Input High current	$V_{CC} = \text{Max.}$, $V_{IN} = 2.7\text{V}$		0.001	20	μA
I_I	Input reverse current	$V_{CC} = \text{Max.}$, $V_{IN} = 7.0\text{V}$		0.001	0.1	mA
I_O	OFF-state (high-impedance) output current	$V_{CC} = \text{Max.}$, $V_O = 5.5\text{V}$, $V_O = 0.5\text{V}$		0.6 -0.050	20 -20	μA μA
V_I	Input clamp voltage	$V_{CC} = \text{Min.}$, $I_{IN} = -18\text{mA}$		-0.8	-1.5	V
I_{SC}	Output short-circuit current	$V_{CC} = \text{Max.}$	-30		-150	mA
I_{CC}	Power supply current	$V_{CC} = \text{Max.}$; all outputs disabled		40	80	mA
t_{PLH}	Input to output	$T_A = 25^\circ\text{C}$, load ²		9	20	ns
t_{PHL}	Input to output	$T_A = 25^\circ\text{C}$, load ²		9	20	ns
SKEW	Output to output	$T_A = 25^\circ\text{C}$, load ²		2	6	ns
t_{LZ}	Enable to output	$T_A = 25^\circ\text{C}$, $C_L = 10\text{pF}$		17	35	ns
t_{HZ}	Enable to output	$T_A = 25^\circ\text{C}$, $C_L = 10\text{pF}$		12	30	ns
t_{ZL}	Enable to output	$T_A = 25^\circ\text{C}$, load ²		14	45	ns
t_{ZH}	Enable to output	$T_A = 25^\circ\text{C}$, load ²		12	40	ns

NOTES:

- All typical values are $T_A = +25^\circ\text{C}$; $V_{CC} = 5.0\text{V}$.
- $C_L = 30\text{pF}$; $V_{IN} = 1.3\text{V}$ to $V_{OUT} = 1.3\text{V}$; $V_{PULSE} = 0\text{V}$ to 3.0V

Quad high-speed differential line driver

AM26LS31

TYPICAL PERFORMANCE CHARACTERISTICS

