

SN54LVTH18652A, SN54LVTH182652A, SN74LVTH18652A, SN74LVTH182652A
3.3-V ABT SCAN TEST DEVICES
WITH 18-BIT TRANSCEIVERS AND REGISTERS

SCBS312B - MARCH 1994 - REVISED JULY 1996

- Members of the Texas Instruments **SCOPE™** Family of Testability Products
- Members of the Texas Instruments **Widebus™** Family
- State-of-the-Art 3.3-V ABT Design Supports Mixed-Mode Signal Operation (5-V Input and Output Voltages With 3.3-V V_{CC})
- Support Unregulated Battery Operation Down to 2.7 V
- Include D-Type Flip-Flops and Control Circuitry to Provide Multiplexed Transmission of Stored and Real-Time Data
- Bus-Hold Data Inputs Eliminate the Need for External Pullup Resistors
- B-Port Outputs of 'LVTH182652A Devices Have Equivalent 25- Ω Series Resistors, So No External Resistors Are Required
- Compatible With the IEEE Standard 1149.1-1990 (JTAG) Test Access Port and Boundary-Scan Architecture
- **SCOPE™** Instruction Set
 - IEEE Standard 1149.1-1990 Required Instructions and Optional CLAMP and HIGHZ
 - Parallel-Signature Analysis at Inputs
 - Pseudo-Random Pattern Generation From Outputs
 - Sample Inputs/Toggle Outputs
 - Binary Count From Outputs
 - Device Identification
 - Even-Parity OpCodes
- Packaged in 64-Pin Plastic Thin Quad Flat (PM) Packages Using 0.5-mm Center-to-Center Spacings and 68-Pin Ceramic Quad Flat (HV) Packages Using 25-mil Center-to-Center Spacings

description

The 'LVTH18652A and 'LVTH182652A scan test devices with 18-bit bus transceivers and registers are members of the Texas Instruments SCOPE™ testability integrated-circuit family. This family of devices supports IEEE Standard 1149.1-1990 boundary scan to facilitate testing of complex circuit-board assemblies. Scan access to the test circuitry is accomplished via the 4-wire test access port (TAP) interface.

Additionally, these devices are designed specifically for low-voltage (3.3-V) V_{CC} operation, but with the capability to provide a TTL interface to a 5-V system environment.

In the normal mode, these devices are 18-bit bus transceivers and registers that allow for multiplexed transmission of data directly from the input bus or from the internal registers. They can be used either as two 9-bit transceivers or one 18-bit transceiver. The test circuitry can be activated by the TAP to take snapshot samples of the data appearing at the device pins or to perform a self test on the boundary-test cells. Activating the TAP in the normal mode does not affect the functional operation of the SCOPE™ bus transceivers and registers.

Data flow in each direction is controlled by clock (CLKAB and CLKBA), select (SAB and SBA), and output-enable (OEAB and OEBA) inputs. For A-to-B data flow, data on the A bus is clocked into the associated registers on the low-to-high transition of CLKAB. When SAB is low, real-time A data is selected for presentation to the B bus (transparent mode). When SAB is high, stored A data is selected for presentation to the B bus (registered mode). When OEAB is high, the B outputs are active. When OEAB is low, the B outputs are in the high-impedance state.

Control for B-to-A data flow is similar to that for A-to-B data flow but uses CLKBA, SBA, and OEBA inputs. Since the OEBA input is active-low, the A outputs are active when OEBA is low and are in the high-impedance state when OEBA is high. Figure 1 illustrates the four fundamental bus-management functions that can be performed with the 'LVTH18652A and 'LVTH182652A.



Please be aware that an important notice concerning availability, standard warranty, and use in critical applications of Texas Instruments semiconductor products and disclaimers thereto appears at the end of this data sheet.

SCOPE and Widebus are trademarks of Texas Instruments Incorporated.

PRODUCT PREVIEW information concerns products in the formative or design phase of development. Characteristic data and other specifications are design goals. Texas Instruments reserves the right to change or discontinue these products without notice.

 **TEXAS
INSTRUMENTS**

POST OFFICE BOX 655303 • DALLAS, TEXAS 75265

Copyright © 1996, Texas Instruments Incorporated

SN54LVTH18652A, SN54LVTH182652A, SN74LVTH18652A, SN74LVTH182652A
3.3-V ABT SCAN TEST DEVICES
WITH 18-BIT TRANSCEIVERS AND REGISTERS

SCBS312B – MARCH 1994 – REVISED JULY 1996

SN74LVTH18652A, SN74LVTH182652A . . . PM PACKAGE
(TOP VIEW)

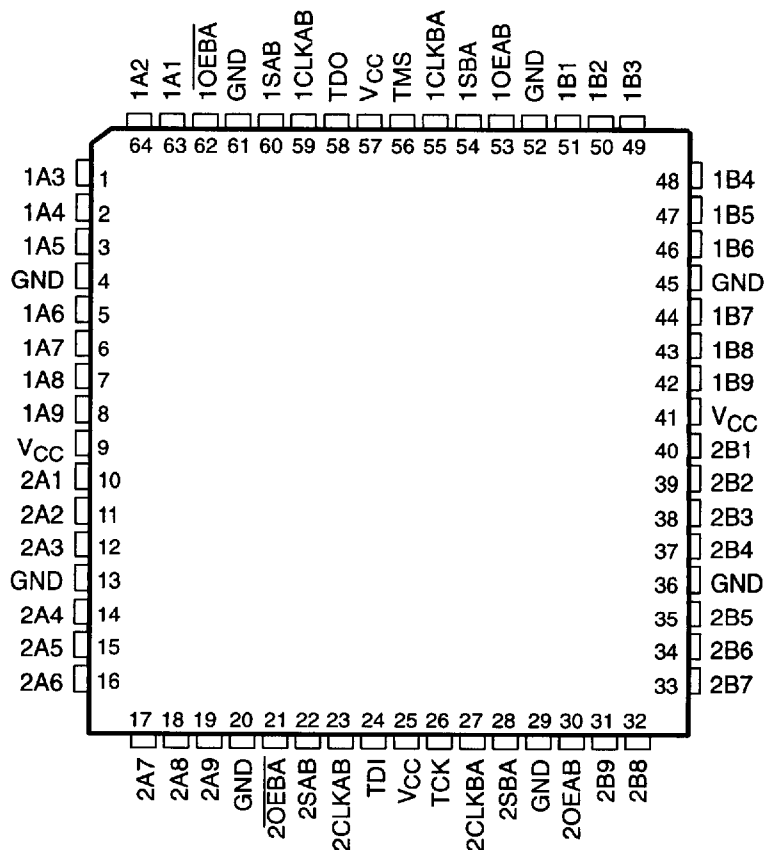

FUNCTION TABLE
(normal mode, each 9-bit section)

INPUTS						DATA I/O		OPERATION OR FUNCTION
OEAB	OEBA	CLKAB	CLKBA	SAB	SBA	A1–A9	B1–B9	
L	H	L	L	X	X	Input disabled	Input disabled	Isolation
L	H	↑	↑	X	X	Input	Input	Store A and B data
X	H	↑	L	X	X	Input	Unspecified†	Store A, hold B
H	H	↑	↑	X‡	X	Input	Output	Store A in both registers
L	X	L	↑	X	X	Unspecified†	Input	Hold A, store B
L	L	↑	↑	X	X‡	Output	Input	Store B in both registers
L	L	X	X	X	L	Output	Input	Real-time B data to A bus
L	L	X	X	X	H	Output	Input	Stored B data to A bus
H	H	X	X	L	X	Input	Output	Real-time A data to B bus
H	H	X	X	H	X	Input	Output	Stored A data to B bus
H	L	X	X	H	H	Output	Output	Stored A data to B bus and stored B data to A bus

† The data-output functions can be enabled or disabled by a variety of level combinations at OEAB or OEBA. Data-input functions are always enabled; i.e., data at the bus pins is stored on every low-to-high transition on the clock inputs.

‡ Select control = L: clocks can occur simultaneously.

Select control = H: clocks must be staggered to load both registers.

PRODUCT PREVIEW



SN54LVTH18652A, SN54LVTH182652A, SN74LVTH18652A, SN74LVTH182652A
 3.3-V ABT SCAN TEST DEVICES
 WITH 18-BIT TRANSCEIVERS AND REGISTERS
 SCBS312B – MARCH 1994 – REVISED JULY 1996

PRODUCT PREVIEW

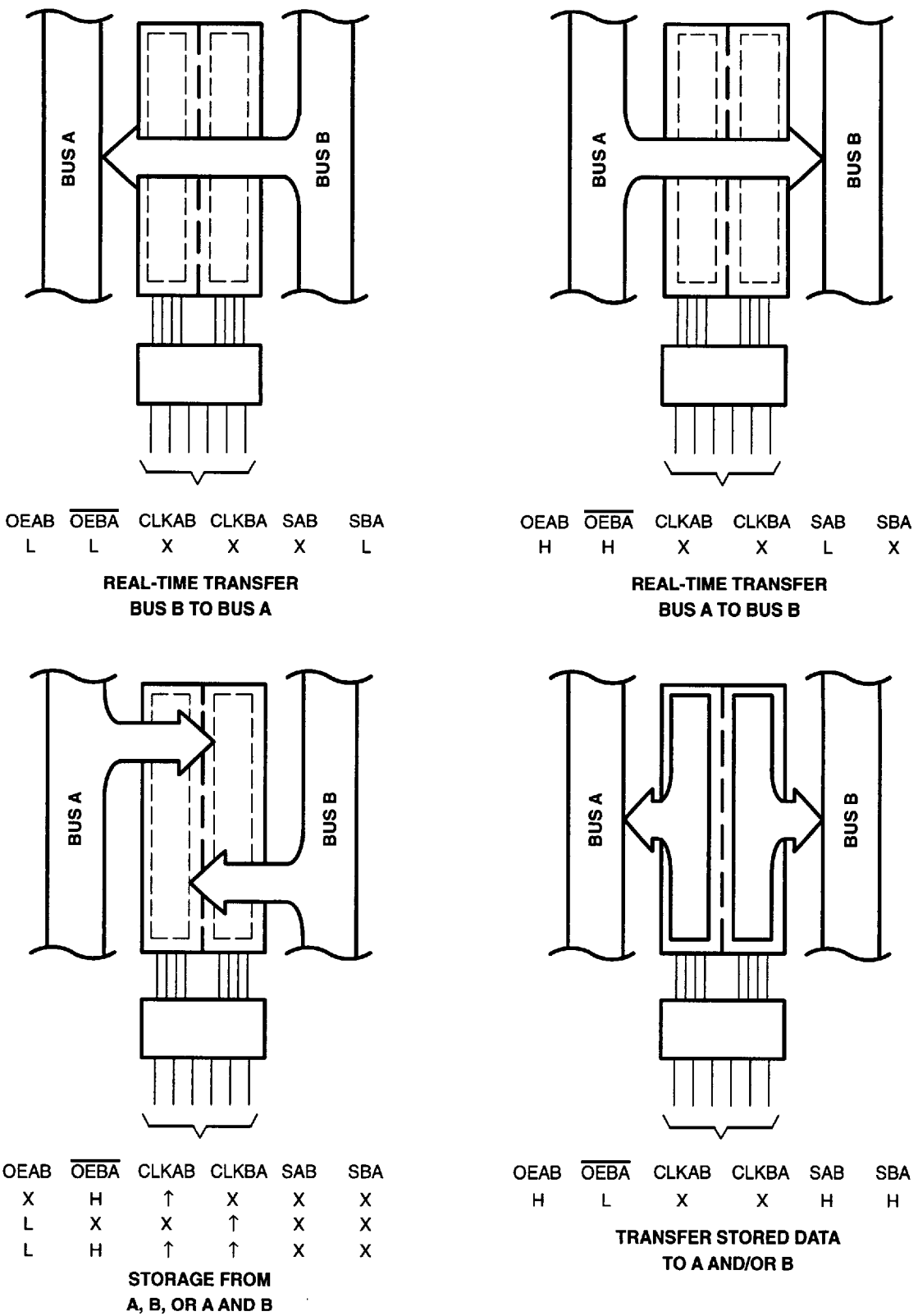
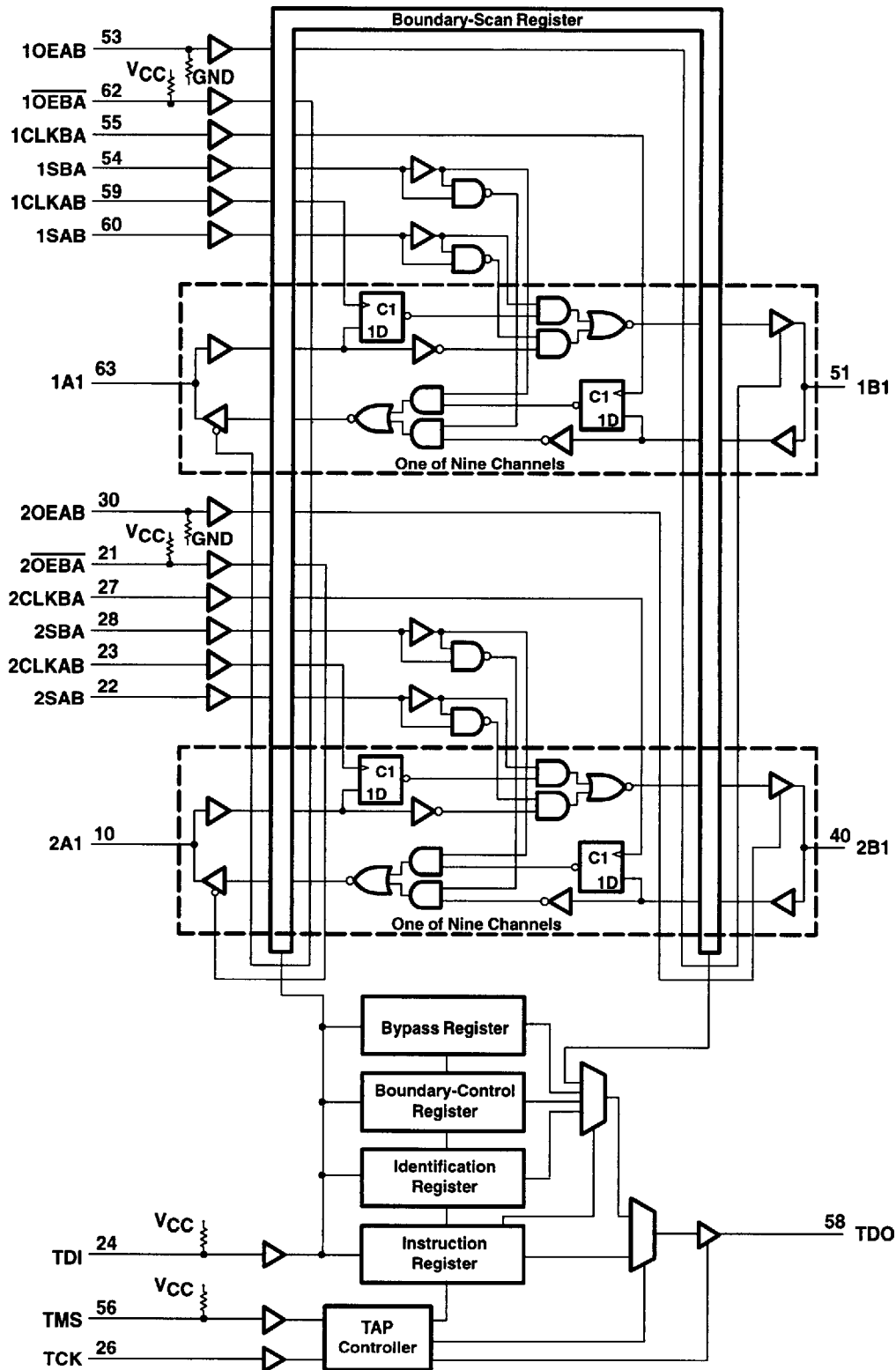

Figure 1. Bus-Management Functions

SN54LVTH18652A, SN54LVTH182652A, SN74LVTH18652A, SN74LVTH182652A
 3.3-V ABT SCAN TEST DEVICES
 WITH 18-BIT TRANSCIEVERS AND REGISTERS

SCBS312B - MARCH 1994 - REVISED JULY 1996

functional block diagram



PRODUCT PREVIEW

Pin numbers shown are for the PM package.



POST OFFICE BOX 655303 • DALLAS, TEXAS 75265

Terminal Functions

TERMINAL NAME	DESCRIPTION
1A1–1A9, 2A1–2A9	Normal-function A-bus I/O ports. See function table for normal-mode logic.
1B1–1B9, 2B1–2B9	Normal-function B-bus I/O ports. See function table for normal-mode logic.
1CLKAB, 1CLKBA, 2CLKAB, 2CLKBA	Normal-function clock inputs. See function table for normal-mode logic.
GND	Ground
1OEAB, 2OEAB	Normal-function active-high output enables. See function table for normal-mode logic. An internal pulldown at each terminal will force the terminal to a low level if left unconnected.
$\overline{1OEBA}$, $\overline{2OEBA}$	Normal-function active-low output enables. See function table for normal-mode logic. An internal pullup at each terminal will force the terminal to a high level if left unconnected.
1SAB, 1SBA, 2SAB, 2SBA	Normal-function select controls. See function table for normal-mode logic.
TCK	Test clock. One of four terminals required by IEEE Standard 1149.1-1990. Test operations of the device are synchronous TCK. Data is captured on the rising edge of TCK and outputs change on the falling edge of TCK.
TDI	Test data input. One of four terminals required by IEEE Standard 1149.1-1990. TDI is the serial input for shifting data through the instruction register or selected data register. An internal pullup forces TDI to a high level if left unconnected.
TDO	Test data output. One of four terminals required by IEEE Standard 1149.1-1990. TDO is the serial output for shifting data through the instruction register or selected data register.
TMS	Test mode select. One of four terminals required by IEEE Standard 1149.1-1990. TMS directs the device through its TAP controller states. An internal pullup forces TMS to a high level if left unconnected.
VCC	Supply voltage

PRODUCT PREVIEW

test architecture

Serial-test information is conveyed by means of a 4-wire test bus or TAP that conforms to IEEE Standard 1149.1-1990. Test instructions, test data, and test control signals all are passed along this serial-test bus. The TAP controller monitors two signals from the test bus, TCK and TMS. The TAP controller extracts the synchronization (TCK) and state control (TMS) signals from the test bus and generates the appropriate on-chip control signals for the test structures in the device. Figure 2 shows the TAP-controller state diagram.

The TAP controller is fully synchronous to the TCK signal. Input data is captured on the rising edge of TCK and output data changes on the falling edge of TCK. This scheme ensures data to be captured is valid for fully one-half of the TCK cycle.

The functional block diagram shows the IEEE Standard 1149.1-1990 4-wire test bus and boundary-scan architecture and the relationship among the test bus, the TAP controller, and the test registers. As shown, the device contains an 8-bit instruction register and four test-data registers: a 48-bit boundary-scan register, a 3-bit boundary-control register, a 1-bit bypass register, and a 32-bit device-identification register.

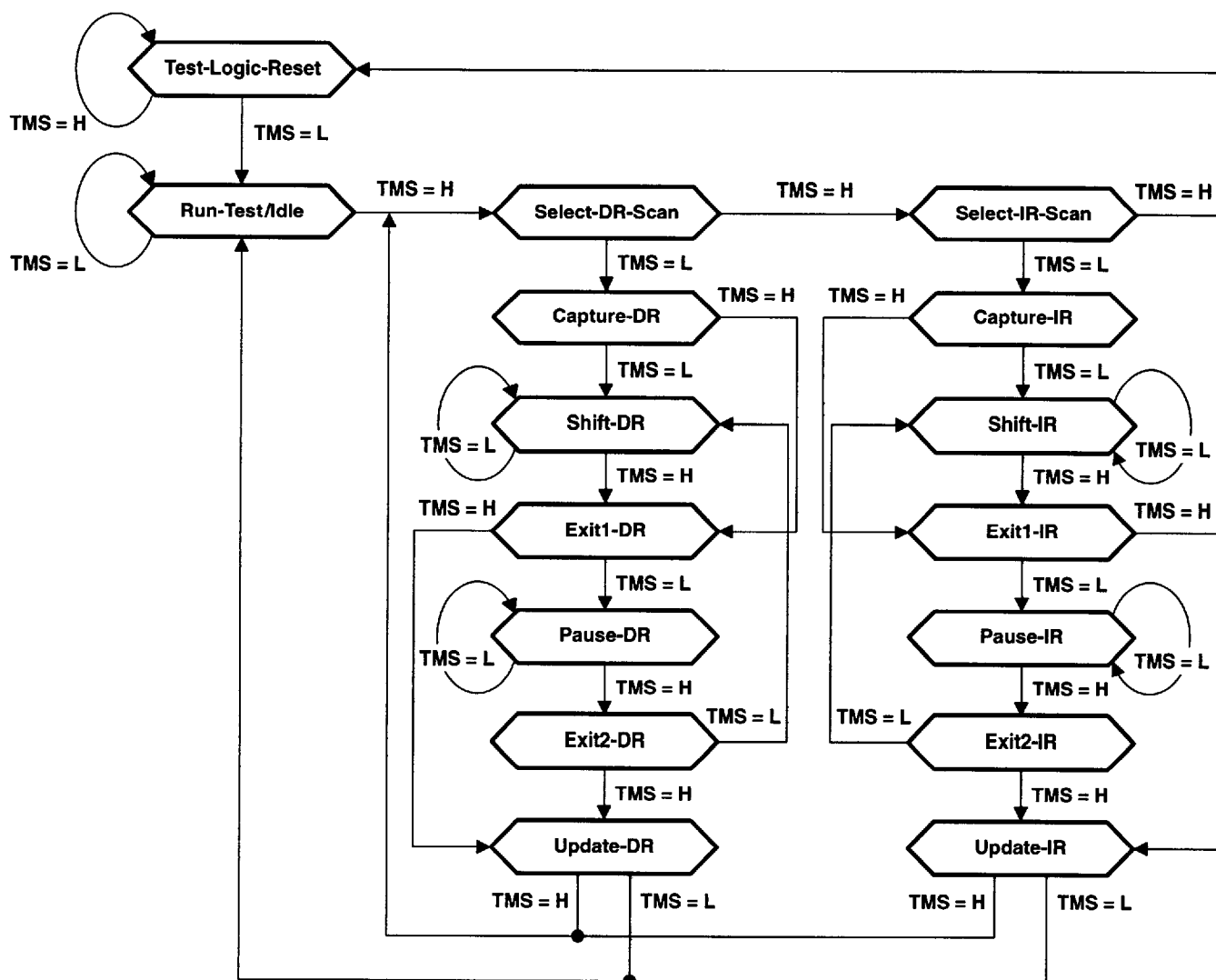

Figure 2. TAP-Controller State Diagram

PRODUCT PREVIEW

state diagram description

The TAP controller is a synchronous finite state machine that provides test control signals throughout the device. The state diagram shown in Figure 2 is in accordance with IEEE Standard 1149.1-1990. The TAP controller proceeds through its states based on the level of TMS at the rising edge of TCK.

As shown, the TAP controller consists of 16 states. There are six stable states (indicated by a looping arrow in the state diagram) and ten unstable states. A stable state is defined as a state the TAP controller can retain for consecutive TCK cycles. Any state that does not meet this criterion is an unstable state.

There are two main paths through the state diagram: one to access and control the selected data register and one to access and control the instruction register. Only one register can be accessed at a time.

Test-Logic-Reset

The device powers up in the Test-Logic-Reset state. In the stable Test-Logic-Reset state, the test logic is reset and is disabled so that the normal logic function of the device is performed. The instruction register is reset to an opcode that selects the optional IDCODE instruction, if supported, or the BYPASS instruction. Certain data registers can also be reset to their power-up values.

The state machine is constructed such that the TAP controller returns to the Test-Logic-Reset state in no more than five TCK cycles if TMS is left high. The TMS pin has an internal pullup resistor that forces it high if left unconnected or if a board defect causes it to be open circuited.

For the 'LVTH18652A and 'LVTH182652A, the instruction register is reset to the binary value 10000001, which selects the IDCODE instruction. Bits 47–46 in the boundary-scan register are reset to logic 0 while bits 45–44 are reset to logic 1, ensuring that these cells, which control A-port and B-port outputs, are set to benign values (i.e., such that if test mode were invoked the outputs would be at high-impedance state). Reset values of other bits in the boundary-scan register should be considered indeterminate. The boundary-control register is reset to the binary value 010, which selects the PSA test operation.

Run-Test/Idle

The TAP controller must pass through the Run-Test/Idle state (from Test-Logic-Reset) before executing any test operations. The Run-Test/Idle state also can be entered following data-register or instruction-register scans. Run-Test/Idle is a stable state in which the test logic can be actively running a test or can be idle. The test operations selected by the boundary-control register are performed while the TAP controller is in the Run-Test/Idle state.

Select-DR-Scan, Select-IR-Scan

No specific function is performed in the Select-DR-Scan and Select-IR-Scan states, and the TAP controller exits either of these states on the next TCK cycle. These states allow the selection of either data-register scan or instruction-register scan.

Capture-DR

When a data-register scan is selected, the TAP controller must pass through the Capture-DR state. In the Capture-DR state, the selected data register can capture a data value as specified by the current instruction. Such capture operations occur on the rising edge of TCK, upon which the TAP controller exits the Capture-DR state.

Shift-DR

Upon entry to the Shift-DR state, the data register is placed in the scan path between TDI and TDO, and on the first falling edge of TCK, TDO goes from the high-impedance state to an active state. TDO enables to the logic level present in the least-significant bit of the selected data register.

Shift-DR (continued)

While in the stable Shift-DR state, data is serially shifted through the selected data register on each TCK cycle. The first shift occurs on the first rising edge of TCK after entry to the Shift-DR state (i.e., no shifting occurs during the TCK cycle in which the TAP controller changes from Capture-DR to Shift-DR or from Exit2-DR to Shift-DR). The last shift occurs on the rising edge of TCK, upon which the TAP controller exits the Shift-DR state.

Exit1-DR, Exit2-DR

The Exit1-DR and Exit2-DR states are temporary states that end a data-register scan. It is possible to return to the Shift-DR state from either Exit1-DR or Exit2-DR without recapturing the data register. On the first falling edge of TCK after entry to Exit1-DR, TDO goes from the active state to the high-impedance state.

Pause-DR

No specific function is performed in the stable Pause-DR state, in which the TAP controller can remain indefinitely. The Pause-DR state suspends and resumes data-register scan operations without loss of data.

Update-DR

If the current instruction calls for the selected data register to be updated with current data, such update occurs on the falling edge of TCK, following entry to the Update-DR state.

Capture-IR

When an instruction-register scan is selected, the TAP controller must pass through the Capture-IR state. In the Capture-IR state, the instruction register captures its current status value. This capture operation occurs on the rising edge of TCK, upon which the TAP controller exits the Capture-IR state. For the 'LVTH18652A and 'LVTH182652A, the status value loaded in the Capture-IR state is the fixed binary value 10000001.

Shift-IR

Upon entry to the Shift-IR state, the instruction register is placed in the scan path between TDI and TDO, and on the first falling edge of TCK, TDO goes from the high-impedance state to the active state. TDO enables to the logic level present in the least-significant bit of the instruction register.

While in the stable Shift-IR state, instruction data is serially shifted through the instruction register on each TCK cycle. The first shift occurs on the first rising edge of TCK after entry to the Shift-IR state (i.e., no shifting occurs during the TCK cycle in which the TAP controller changes from Capture-IR to Shift-IR or from Exit2-IR to Shift-IR). The last shift occurs on the rising edge of TCK, upon which the TAP controller exits the Shift-IR state.

Exit1-IR, Exit2-IR

The Exit1-IR and Exit2-IR states are temporary states that end an instruction-register scan. It is possible to return to the Shift-IR state from either Exit1-IR or Exit2-IR without recapturing the instruction register. On the first falling edge of TCK after entry to Exit1-IR, TDO goes from the active state to the high-impedance state.

Pause-IR

No specific function is performed in the stable Pause-IR state, in which the TAP controller can remain indefinitely. The Pause-IR state suspends and resumes instruction-register scan operations without loss of data.

Update-IR

The current instruction is updated and takes effect on the falling edge of TCK, following entry to the Update-IR state.



register overview

With the exception of the bypass and device-identification registers, any test register can be thought of as a serial-shift register with a shadow latch on each bit. The bypass and device identification registers differ in that they contain only a shift register. During the appropriate capture state (Capture-IR for instruction register, Capture-DR for data registers), the shift register can be parallel loaded from a source specified by the current instruction. During the appropriate shift state (Shift-IR or Shift-DR), the contents of the shift register are shifted out from TDO while new contents are shifted in at TDI. During the appropriate update state (Update-IR or Update-DR), the shadow latches are updated from the shift register.

instruction register description

The instruction register (IR) is eight bits long and tells the device what instruction is to be executed. Information contained in the instruction includes the mode of operation (either normal mode, in which the device performs its normal logic function, or test mode, in which the normal logic function is inhibited or altered), the test operation to be performed, which of the four data registers is to be selected for inclusion in the scan path during data-register scans, and the source of data to be captured into the selected data register during Capture-DR.

Table 3 lists the instructions supported by the 'LVTH18652A and 'LVTH182652A. The even-parity feature specified for SCOPE™ devices is supported in this device. Bit 7 of the instruction opcode is the parity bit. Any instructions that are defined for SCOPE™ devices but are not supported by this device default to BYPASS.

During Capture-IR, the IR captures the binary value 10000001. As an instruction is shifted in, this value is shifted out via TDO and can be inspected as verification that the IR is in the scan path. During Update-IR, the value that has been shifted into the IR is loaded into shadow latches. At this time, the current instruction is updated and any specified mode change takes effect. At power up or in the Test-Logic-Reset state, the IR is reset to the binary value 10000001, which selects the IDCODE instruction. The IR order of scan is shown in Figure 3.

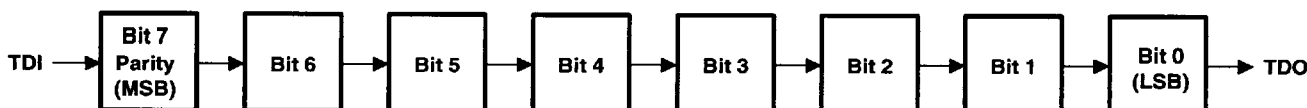

Figure 3. Instruction Register Order of Scan

PRODUCT PREVIEW

data register description

boundary-scan register

The boundary-scan register (BSR) is 48 bits long. It contains one boundary-scan cell (BSC) for each normal-function input pin and one BSC for each normal-function I/O pin (one single cell for both input data and output data). The BSR is used 1) to store test data that is to be applied externally to the device output pins, and/or 2) to capture data that appears internally at the outputs of the normal on-chip logic and/or externally at the device input pins.

The source of data to be captured into the BSR during Capture-DR is determined by the current instruction. The contents of the BSR can change during Run-Test/Idle, as determined by the current instruction. At power up or in Test-Logic-Reset, BSCs 47–46 are reset to logic 0 while BSCs 45–44 are reset to logic 1, ensuring that these cells, which control A-port and B-port outputs, are set to benign values (i.e., if test mode were invoked the outputs would be at high-impedance state). Reset values of other BSCs should be considered indeterminate.

The BSR order of scan is from TDI through bits 47–0 to TDO. Table 1 shows the BSR bits and their associated device pin signals.

Table 1. Boundary-Scan Register Configuration

BSR BIT NUMBER	DEVICE SIGNAL	BSR BIT NUMBER	DEVICE SIGNAL	BSR BIT NUMBER	DEVICE SIGNAL
47	2OEAB	35	2A9-I/O	17	2B9-I/O
46	1OEAB	34	2A8-I/O	16	2B8-I/O
45	2OEBA	33	2A7-I/O	15	2B7-I/O
44	1OEBA	32	2A6-I/O	14	2B6-I/O
43	2CLKAB	31	2A5-I/O	13	2B5-I/O
42	1CLKAB	30	2A4-I/O	12	2B4-I/O
41	2CLKBA	29	2A3-I/O	11	2B3-I/O
40	1CLKBA	28	2A2-I/O	10	2B2-I/O
39	2SAB	27	2A1-I/O	9	2B1-I/O
38	1SAB	26	1A9-I/O	8	1B9-I/O
37	2SBA	25	1A8-I/O	7	1B8-I/O
36	1SBA	24	1A7-I/O	6	1B7-I/O
—	—	23	1A6-I/O	5	1B6-I/O
—	—	22	1A5-I/O	4	1B5-I/O
—	—	21	1A4-I/O	3	1B4-I/O
—	—	20	1A3-I/O	2	1B3-I/O
—	—	19	1A2-I/O	1	1B2-I/O
—	—	18	1A1-I/O	0	1B1-I/O

PRODUCT PREVIEW



SN54LVTH18652A, SN54LVTH182652A, SN74LVTH18652A, SN74LVTH182652A
3.3-V ABT SCAN TEST DEVICES
WITH 18-BIT TRANSCEIVERS AND REGISTERS

SCBS312B – MARCH 1994 – REVISED JULY 1996

boundary-control register

The boundary-control register (BCR) is three bits long. The BCR is used in the context of the RUNT instruction to implement additional test operations not included in the basic SCOPE™ instruction set. Such operations include PRPG, PSA, and binary count up (COUNT). Table 4 shows the test operations that are decoded by the BCR.

During Capture-DR, the contents of the BCR are not changed. At power up or in Test-Logic-Reset, the BCR is reset to the binary value 010, which selects the PSA test operation. The BCR order of scan is shown in Figure 4.

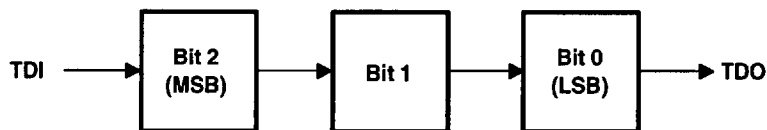

Figure 4. Boundary-Control Register Order of Scan

bypass register

The bypass register is a 1-bit scan path that can be selected to shorten the length of the system scan path, reducing the number of bits per test pattern that must be applied to complete a test operation. During Capture-DR, the bypass register captures a logic 0. The bypass register order of scan is shown in Figure 5.

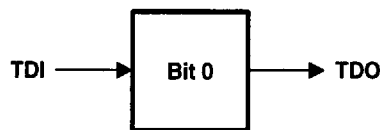

Figure 5. Bypass Register Order of Scan

PRODUCT PREVIEW

SN54LVTH18652A, SN54LVTH182652A, SN74LVTH18652A, SN74LVTH182652A
3.3-V ABT SCAN TEST DEVICES
WITH 18-BIT TRANSCEIVERS AND REGISTERS

SCBS312B – MARCH 1994 – REVISED JULY 1996

device-identification register

The device-identification register (IDR) is 32 bits long. It can be selected and read to identify the manufacturer, part number, and version of this device.

For the 'LVTH18652A, the binary value 0010000000000011111000000101111 (2001F02F, hex) is captured (during Capture-DR state) in the device-identification register to identify this device as Texas Instruments SN54/74LVTH18652A.

For the 'LVTH182652A, the binary value 00100000000000100100000000101111 (2002402F, hex) is captured (during Capture-DR state) in the device-identification register to identify this device as Texas Instruments SN54/74LVTH182652A.

The device-identification register order of scan is from TDI through bits 31–0 to TDO. Table 2 shows the device-identification register bits and their significance.

Table 2. Device-Identification Register Configuration

IDR BIT NUMBER	IDENTIFICATION SIGNIFICANCE	IDR BIT NUMBER	IDENTIFICATION SIGNIFICANCE	IDR BIT NUMBER	IDENTIFICATION SIGNIFICANCE
31	VERSION3	27	PARTNUMBER15	11	MANUFACTURER10†
30	VERSION2	26	PARTNUMBER14	10	MANUFACTURER09†
29	VERSION1	25	PARTNUMBER13	9	MANUFACTURER08†
28	VERSION0	24	PARTNUMBER12	8	MANUFACTURER07†
—	—	23	PARTNUMBER11	7	MANUFACTURER06†
—	—	22	PARTNUMBER10	6	MANUFACTURER05†
—	—	21	PARTNUMBER09	5	MANUFACTURER04†
—	—	20	PARTNUMBER08	4	MANUFACTURER03†
—	—	19	PARTNUMBER07	3	MANUFACTURER02†
—	—	18	PARTNUMBER06	2	MANUFACTURER01†
—	—	17	PARTNUMBER05	1	MANUFACTURER00†
—	—	16	PARTNUMBER04	0	LOGIC1†
—	—	15	PARTNUMBER03	—	—
—	—	14	PARTNUMBER02	—	—
—	—	13	PARTNUMBER01	—	—
—	—	12	PARTNUMBER00	—	—

† Note that for TI products, bits 11–0 of the device-identification register always contain the binary value 000000101111 (02F, hex).

PRODUCT PREVIEW



8961723 0107189 43T

SN54LVTH18652A, SN54LVTH182652A, SN74LVTH18652A, SN74LVTH182652A
3.3-V ABT SCAN TEST DEVICES
WITH 18-BIT TRANSCEIVERS AND REGISTERS

SCBS312B – MARCH 1994 – REVISED JULY 1996

instruction-register opcode description

The instruction-register opcodes are shown in Table 3. The following descriptions detail the operation of each instruction.

Table 3. Instruction-Register Opcodes

BINARY CODE† BIT 7 → BIT 0 MSB → LSB	SCOPE OPCODE	DESCRIPTION	SELECTED DATA REGISTER	MODE
00000000	EXTEST	Boundary scan	Boundary scan	Test
10000001	IDCODE	Identification read	Device identification	Normal
10000010	SAMPLE/PRELOAD	Sample boundary	Boundary scan	Normal
00000011	BYPASS‡	Bypass scan	Bypass	Normal
10000100	BYPASS‡	Bypass scan	Bypass	Normal
00000101	BYPASS‡	Bypass scan	Bypass	Normal
00000110	HIGHZ	Control boundary to high impedance	Bypass	Modified test
10000111	CLAMP	Control boundary to 1/0	Bypass	Test
10001000	BYPASS‡	Bypass scan	Bypass	Normal
00001001	RUNT	Boundary run test	Bypass	Test
00001010	READBN	Boundary read	Boundary scan	Normal
10001011	READBT	Boundary read	Boundary scan	Test
00001100	CELLTST	Boundary self test	Boundary scan	Normal
10001101	TOPHIP	Boundary toggle outputs	Bypass	Test
10001110	SCANCN	Boundary-control register scan	Boundary control	Normal
00001111	SCANCT	Boundary-control register scan	Boundary control	Test
All others	BYPASS	Bypass scan	Bypass	Normal

† Bit 7 is used to maintain even parity in the 8-bit instruction.

‡ The BYPASS instruction is executed in lieu of a SCOPE™ instruction that is not supported in the 'LVT18652 or 'LVT182652.

boundary scan

This instruction conforms to the IEEE Standard 1149.1-1990 EXTEST instruction. The BSR is selected in the scan path. Data appearing at the device input and I/O pins is captured in the associated BSCs. Data that has been scanned into the I/O BSCs for pins in the output mode is applied to the device I/O pins. Data present at the device pins, except for output enables, is passed through the BSCs to the normal on-chip logic. For I/O pins, the operation of a pin as input or output is determined by the contents of the output-enable BSCs (bits 47–44 of the BSR). When a given output enable is active (logic 0 for OEBA, logic 1 for OEAB), the associated I/O pins operate in the output mode. Otherwise, the I/O pins operate in the input mode. The device operates in the test mode.

identification read

This instruction conforms to the IEEE Standard 1149.1-1990 IDCODE instruction. The device identification register is selected in the scan path. The device operates in the normal mode.

sample boundary

This instruction conforms to the IEEE Standard 1149.1-1990 SAMPLE/PRELOAD instruction. The BSR is selected in the scan path. Data appearing at the device input pins and I/O pins in the input mode is captured in the associated BSCs, while data appearing at the outputs of the normal on-chip logic is captured in the BSCs associated with I/O pins in the output mode. The device operates in the normal mode.

PRODUCT PREVIEW



POST OFFICE BOX 655303 • DALLAS, TEXAS 75265

bypass scan

This instruction conforms to the IEEE Standard 1149.1-1990 BYPASS instruction. The bypass register is selected in the scan path. A logic 0 value is captured in the bypass register during Capture-DR. The device operates in the normal mode.

control boundary to high impedance

This instruction conforms to the IEEE Standard 1149.1a-1993 HIGHZ instruction. The bypass register is selected in the scan path. A logic 0 value is captured in the bypass register during Capture-DR. The device operates in a modified test mode in which all device I/O pins are placed in the high-impedance state, the device input pins remain operational, and the normal on-chip logic function is performed.

control boundary to 1/0

This instruction conforms to the IEEE Standard 1149.1a-1993 CLAMP instruction. The bypass register is selected in the scan path. A logic 0 value is captured in the bypass register during Capture-DR. Data in the I/O BSCs for pins in the output mode is applied to the device I/O pins. The device operates in the test mode.

boundary-run test

The bypass register is selected in the scan path. A logic 0 value is captured in the bypass register during Capture-DR. The device operates in the test mode. The test operation specified in the BCR is executed during Run-Test/Idle. The five test operations decoded by the BCR are: sample inputs/toggle outputs (TOPSIP), PRPG, PSA, simultaneous PSA and PRPG (PSA/PRPG), and simultaneous PSA and binary count up (PSA/COUNT).

boundary read

The BSR is selected in the scan path. The value in the BSR remains unchanged during Capture-DR. This instruction is useful for inspecting data after a PSA operation.

boundary self test

The BSR is selected in the scan path. All BSCs capture the inverse of their current values during Capture-DR. In this way, the contents of the shadow latches can be read out to verify the integrity of both shift-register and shadow-latch elements of the BSR. The device operates in the normal mode.

boundary toggle outputs

The bypass register is selected in the scan path. A logic 0 value is captured in the bypass register during Capture-DR. Data in the shift-register elements of the selected output-mode BSCs is toggled on each rising edge of TCK in Run-Test/Idle and is then updated in the shadow latches and applied to the associated device I/O pins on each falling edge of TCK in Run-Test/Idle. Data in the input-mode BSCs remains constant. Data appearing at the device input or I/O pins is not captured in the input-mode BSCs. The device operates in the test mode.

boundary-control-register scan

The BCR is selected in the scan path. The value in the BCR remains unchanged during Capture-DR. This operation must be performed before a boundary-run test operation to specify which test operation is to be executed.



SN54LVTH18652A, SN54LVTH182652A, SN74LVTH18652A, SN74LVTH182652A
3.3-V ABT SCAN TEST DEVICES
WITH 18-BIT TRANSCEIVERS AND REGISTERS

SCBS312B – MARCH 1994 – REVISED JULY 1996

boundary-control-register opcode description

The BCR opcodes are decoded from BCR bits 2–0 as shown in Table 4. The selected test operation is performed while the RUNT instruction is executed in the Run-Test/Idle state. The following descriptions detail the operation of each BCR instruction and illustrate the associated PSA and PRPG algorithms.

Table 4. Boundary-Control Register Opcodes

BINARY CODE BIT 2 → BIT 0 MSB → LSB	DESCRIPTION
X00	Sample inputs/toggle outputs (TOPSIP)
X01	Pseudo-random pattern generation/36-bit mode (PRPG)
X10	Parallel-signature analysis/36-bit mode (PSA)
011	Simultaneous PSA and PRPG/18-bit mode (PSA/PRPG)
111	Simultaneous PSA and binary count up/18-bit mode (PSA/COUNT)

While the control input BSCs (bits 47–36) are not included in the toggle, PSA, PRPG, or COUNT algorithms, the output-enable BSCs (bits 47–44 of the BSR) control the drive state (active or high impedance) of the selected device output pins. These BCR instructions are only valid when both bytes of the device are operating in one direction of data flow (that is, $1OEAB = \overline{1OEBA}$ and $2OEAB = \overline{2OEBA}$) and in the same direction of data flow (that is, $1OEAB = 2OEAB$ and $\overline{1OEBA} = \overline{2OEBA}$). Otherwise, the bypass instruction is operated.

sample inputs/toggle outputs (TOPSIP)

Data appearing at the selected device input-mode I/O pins is captured in the shift-register elements of the associated BSCs on each rising edge of TCK. Data in the shift-register elements of the selected output-mode BSCs is toggled on each rising edge of TCK, updated in the shadow latches, and applied to the associated device I/O pins on each falling edge of TCK.

PRODUCT PREVIEW



POST OFFICE BOX 655303 • DALLAS, TEXAS 75265

SN54LVTH18652A, SN54LVTH182652A, SN74LVTH18652A, SN74LVTH182652A
3.3-V ABT SCAN TEST DEVICES
WITH 18-BIT TRANSCEIVERS AND REGISTERS

SCBS312B – MARCH 1994 – REVISED JULY 1996

pseudo-random pattern generation (PRPG)

A pseudo-random pattern is generated in the shift-register elements of the selected BSCs on each rising edge of TCK, updated in the shadow latches, and applied to the associated device output-mode I/O pins on each falling edge of TCK. Figures 6 and 7 illustrate the 36-bit linear-feedback shift-register algorithms through which the patterns are generated. An initial seed value should be scanned into the BSR prior to performing this operation. A seed value of all zeroes will not produce additional patterns.

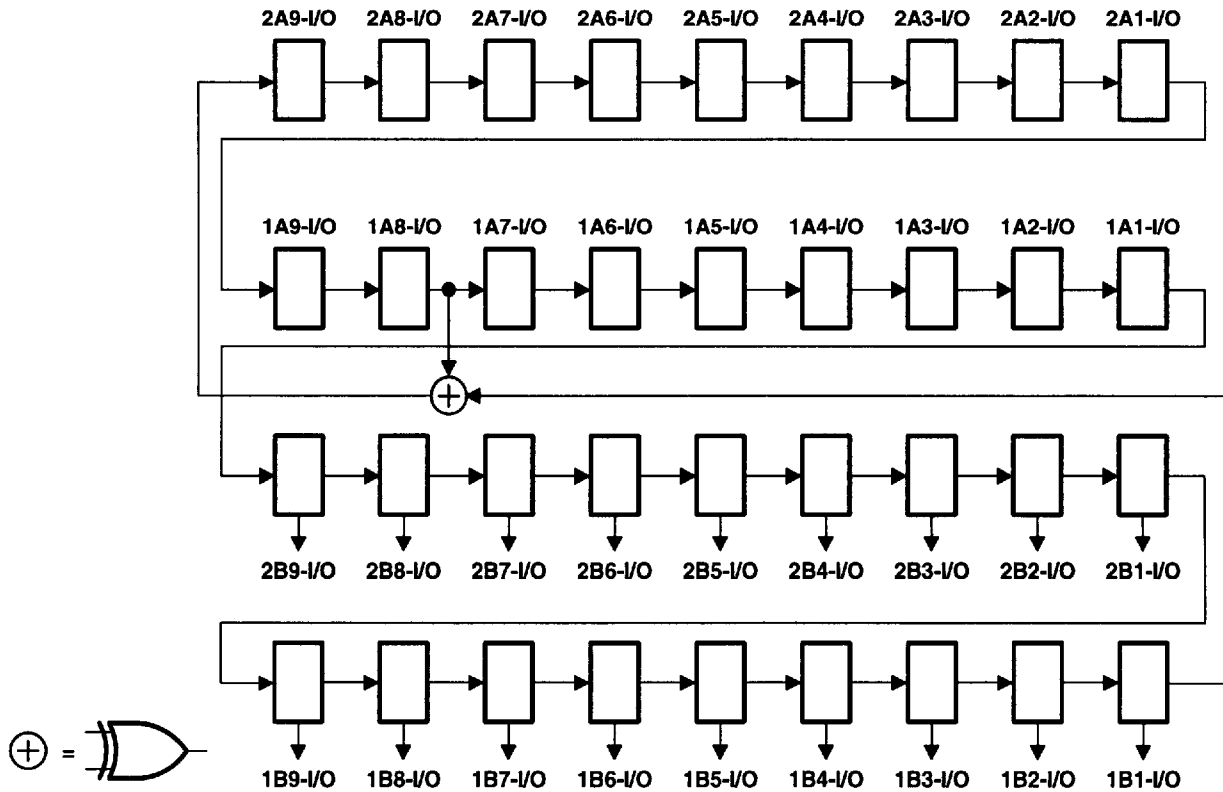

Figure 6. 36-Bit PRPG Configuration (1OEAB = 2OEAB = 1, 1OEBA = 2OEBA = 1)

PRODUCT PREVIEW



POST OFFICE BOX 655303 • DALLAS, TEXAS 75265

SN54LVTH18652A, SN54LVTH182652A, SN74LVTH18652A, SN74LVTH182652A
 3.3-V ABT SCAN TEST DEVICES
 WITH 18-BIT TRANSCEIVERS AND REGISTERS

SCBS312B - MARCH 1994 - REVISED JULY 1996

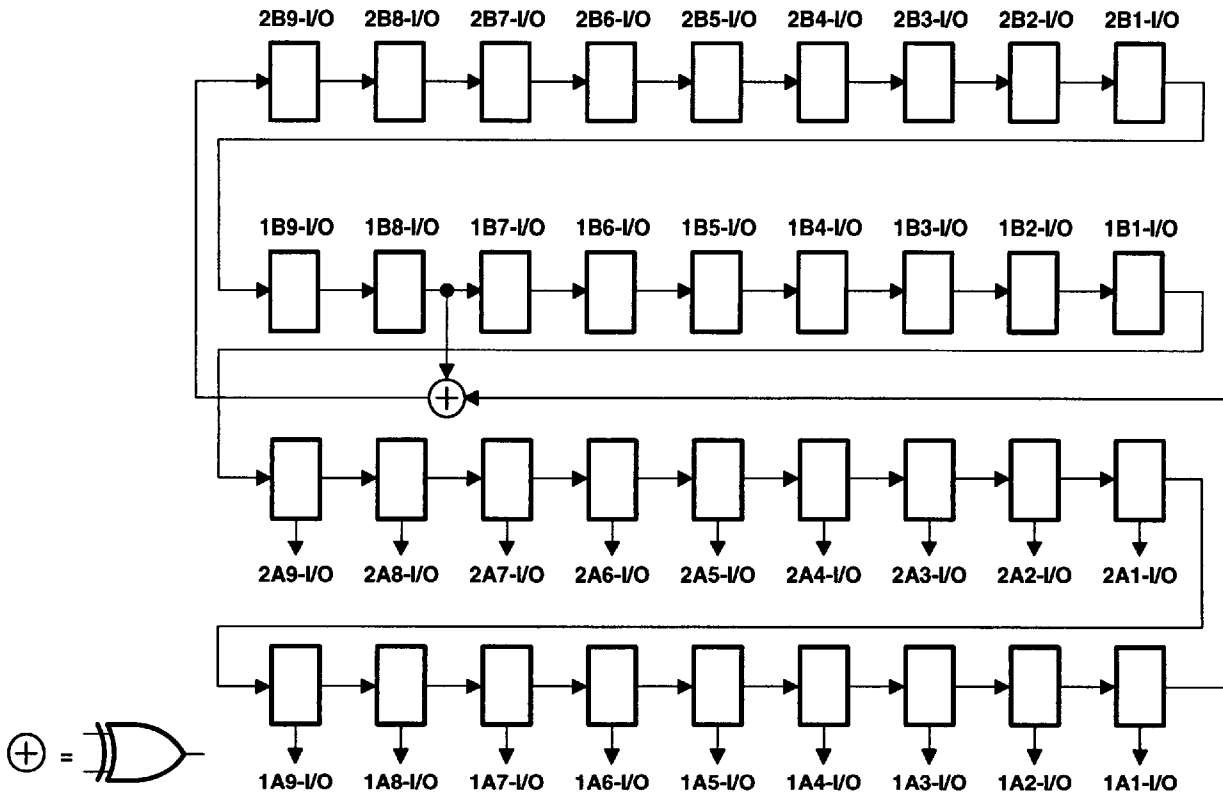

Figure 7. 36-Bit PRPG Configuration (1OEAB = 2OEAB = 0, 1OEBA = 2OEBA = 0)

PRODUCT PREVIEW



POST OFFICE BOX 655303 • DALLAS, TEXAS 75265

parallel-signature analysis (PSA)

Data appearing at the selected device input-mode I/O pins is compressed into a 36-bit parallel signature in the shift-register elements of the selected BSCs on each rising edge of TCK. Data in the shadow latches of the selected output-mode BSCs remains constant and is applied to the associated device I/O pins. Figures 8 and 9 illustrate the 36-bit linear-feedback shift-register algorithms through which the signature is generated. An initial seed value should be scanned into the BSR before performing this operation.

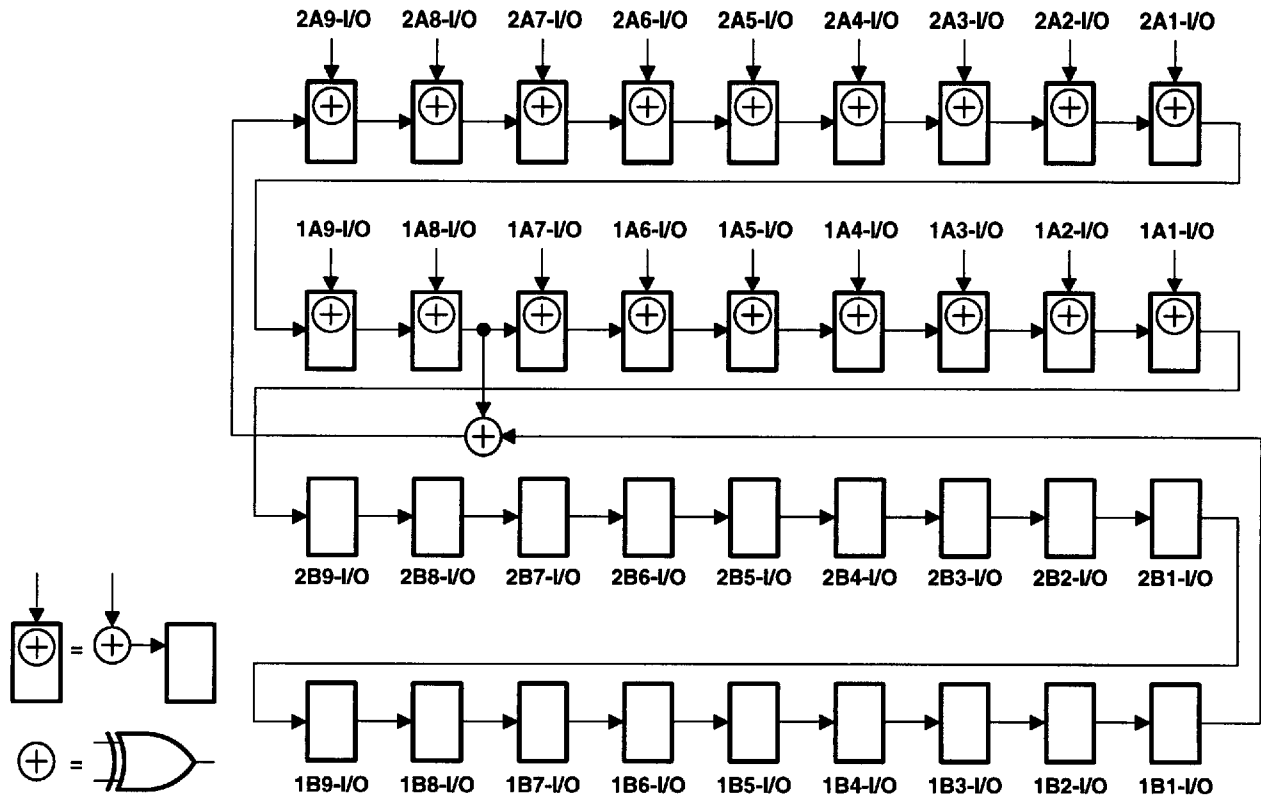

Figure 8. 36-Bit PSA Configuration (1OEAB = 2OEAB = 1, 1OEBA = 2OEBA = 1)

PRODUCT PREVIEW

SN54LVTH18652A, SN54LVTH182652A, SN74LVTH18652A, SN74LVTH182652A
 3.3-V ABT SCAN TEST DEVICES
 WITH 18-BIT TRANSCEIVERS AND REGISTERS
 SCBS312B – MARCH 1994 – REVISED JULY 1996

PRODUCT PREVIEW

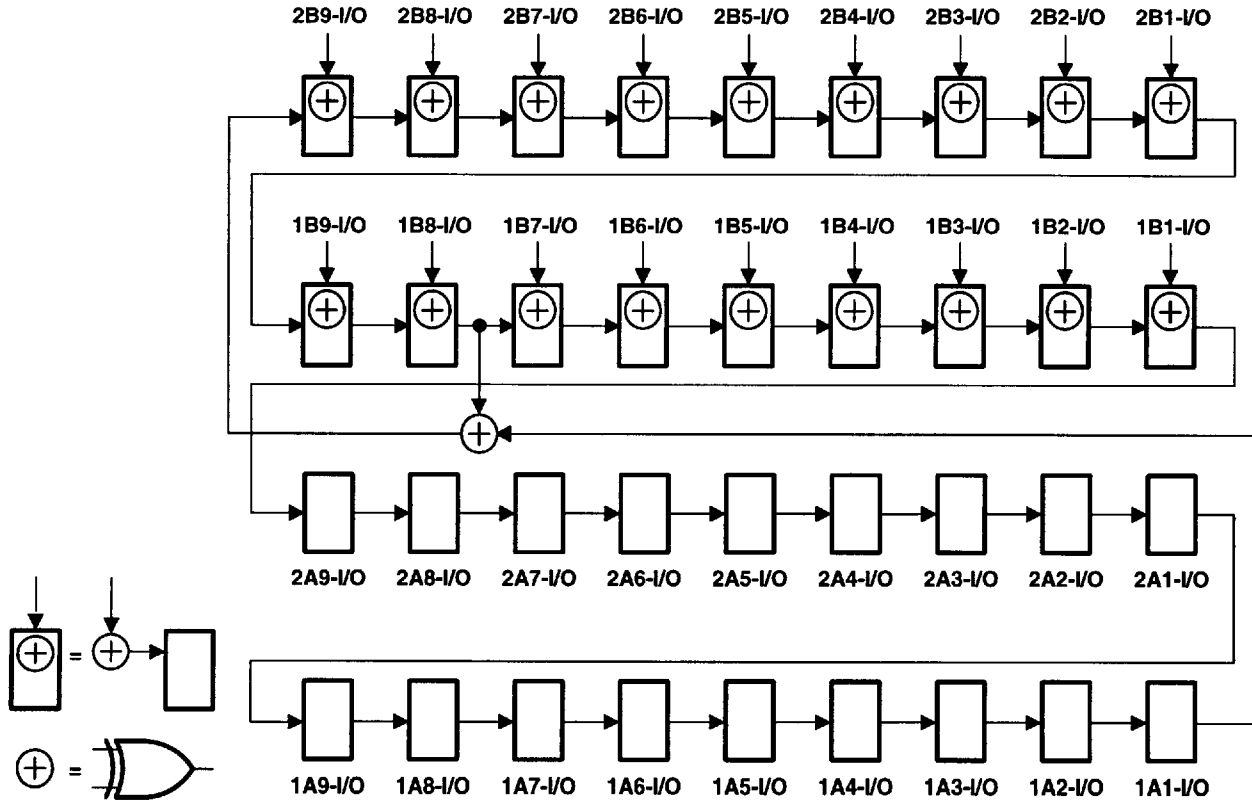

Figure 9. 36-Bit PSA Configuration (1OEAB = 2OEAB = 0, 1OEBA = 2OEBA = 0)

SN54LVTH18652A, SN54LVTH182652A, SN74LVTH18652A, SN74LVTH182652A
3.3-V ABT SCAN TEST DEVICES
WITH 18-BIT TRANSCEIVERS AND REGISTERS

SCBS312B – MARCH 1994 – REVISED JULY 1996

simultaneous PSA and PRPG (PSA/PRPG)

Data appearing at the selected device input-mode I/O pins is compressed into an 18-bit parallel signature in the shift-register elements of the selected input-mode BSCs on each rising edge of TCK. At the same time, an 18-bit pseudo-random pattern is generated in the shift-register elements of the selected output-mode BSCs on each rising edge of TCK, updated in the shadow latches, and applied to the associated device I/O pins on each falling edge of TCK. Figures 10 and 11 illustrate the 18-bit linear-feedback shift-register algorithms through which the signature and patterns are generated. An initial seed value should be scanned into the BSR before performing this operation. A seed value of all zeroes will not produce additional patterns.

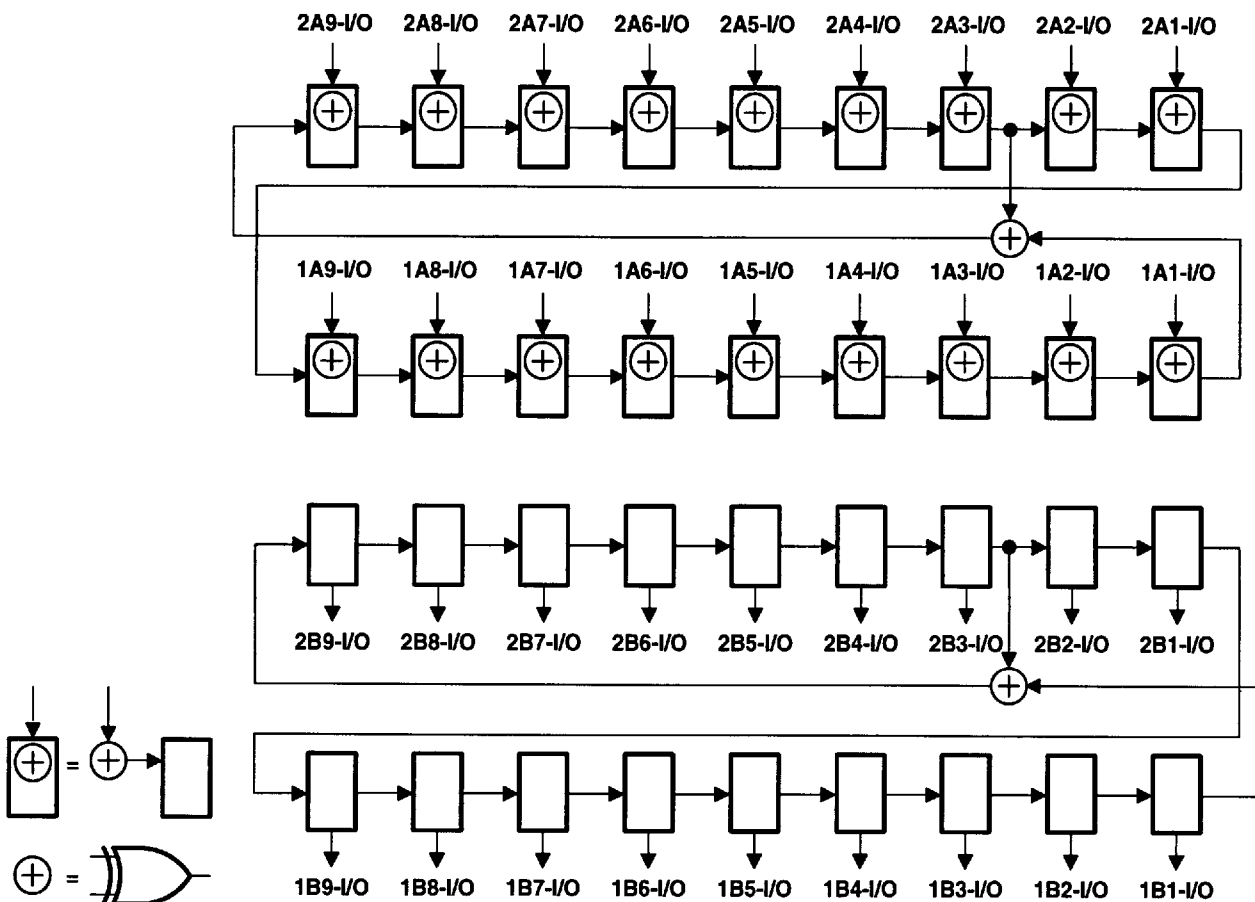

Figure 10. 18-Bit PSA/PRPG Configuration (1OEAB = 2OEAB = 1, 1OEBA = 2OEBA = 1)

PRODUCT PREVIEW

SN54LVTH18652A, SN54LVTH182652A, SN74LVTH18652A, SN74LVTH182652A
 3.3-V ABT SCAN TEST DEVICES
 WITH 18-BIT TRANSCEIVERS AND REGISTERS
 SCBS312B – MARCH 1994 – REVISED JULY 1996

PRODUCT PREVIEW

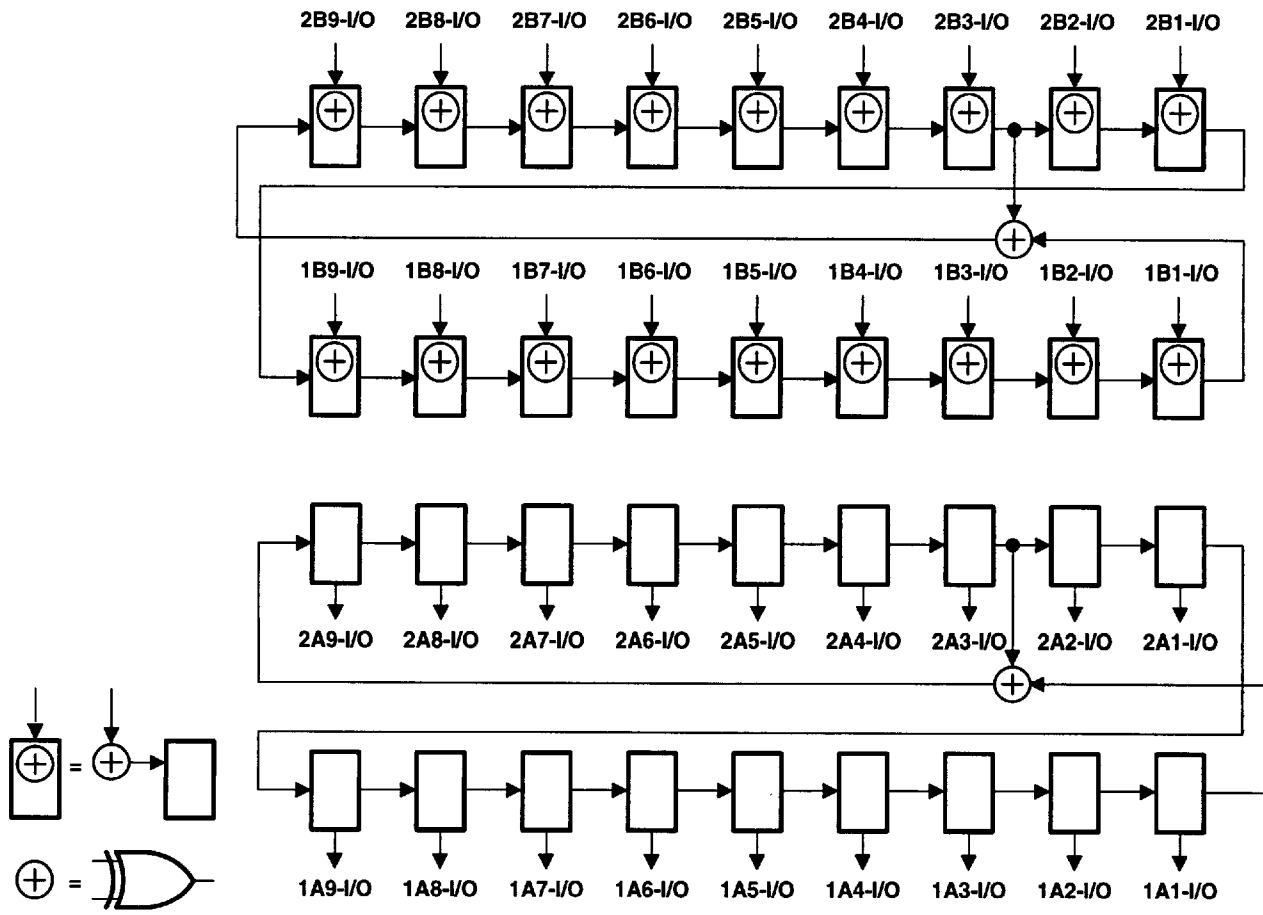

Figure 11. 18-Bit PSA/PRPG Configuration (1OEAB = 2OEAB = 0, 1OEBA = 2OEBA = 0)

simultaneous PSA and binary count up (PSA/COUNT)

Data appearing at the selected device input-mode I/O pins is compressed into an 18-bit parallel signature in the shift-register elements of the selected input-mode BSCs on each rising edge of TCK. At the same time, an 18-bit binary count-up pattern is generated in the shift-register elements of the selected output-mode BSCs on each rising edge of TCK, updated in the shadow latches, and applied to the associated device I/O pins on each falling edge of TCK. Figures 12 and 13 illustrate the 18-bit linear-feedback shift-register algorithms through which the signature is generated. An initial seed value should be scanned into the BSR before performing this operation.

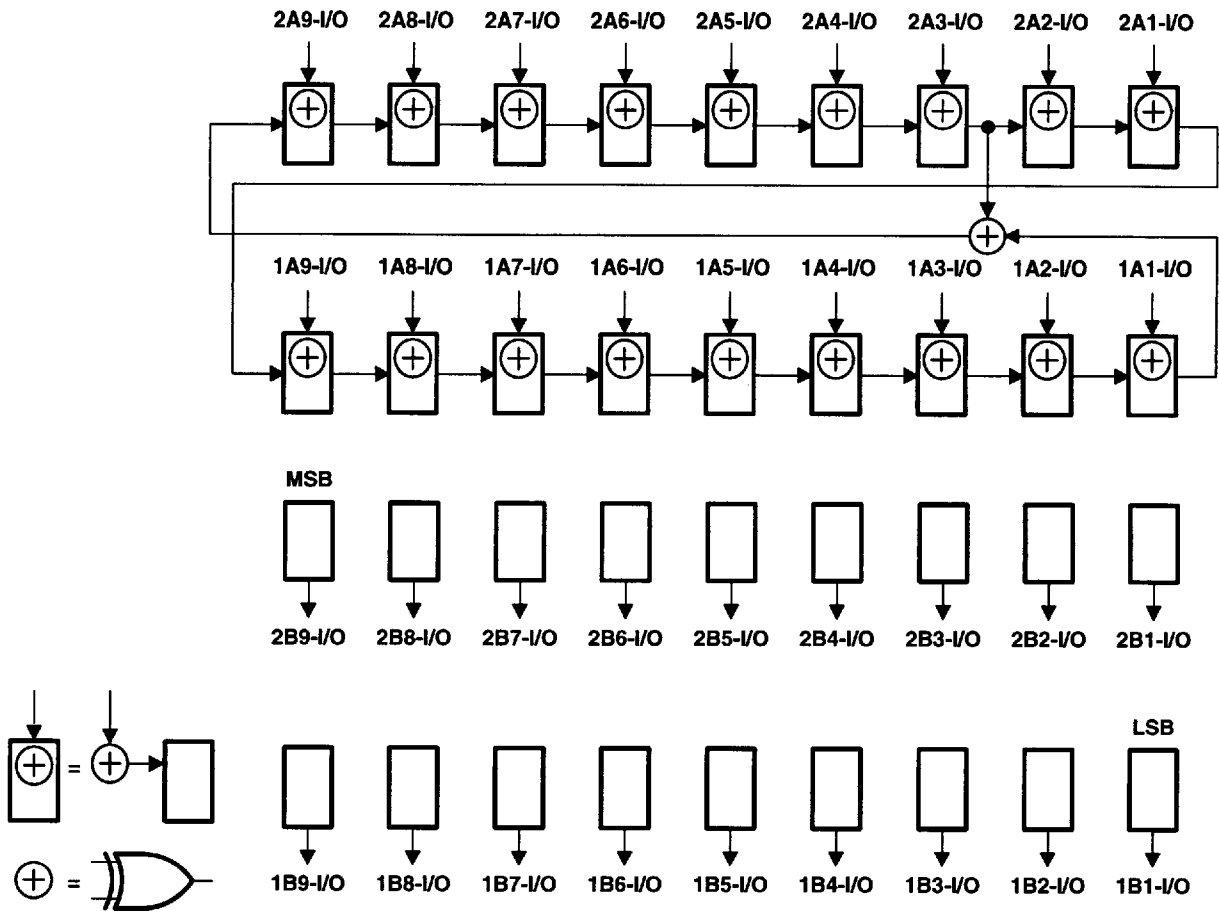

Figure 12. 18-Bit PSA/COUNT Configuration (1OEAB = 2OEAB = 1, 1OEBA = 2OEBA = 1)

PRODUCT PREVIEW

SN54LVTH18652A, SN54LVTH182652A, SN74LVTH18652A, SN74LVTH182652A
 3.3-V ABT SCAN TEST DEVICES
 WITH 18-BIT TRANSCEIVERS AND REGISTERS

SCBS312B – MARCH 1994 – REVISED JULY 1996

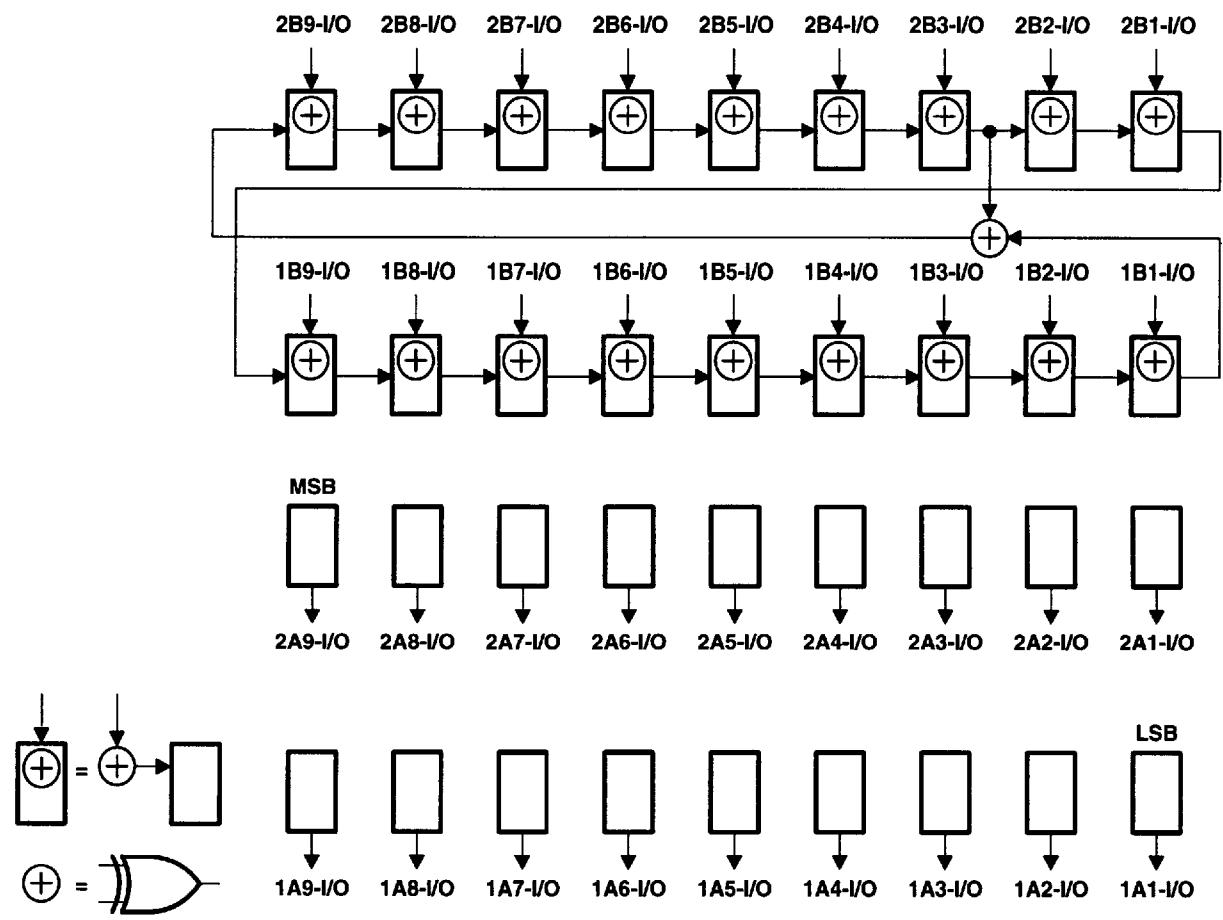

Figure 13. 18-Bit PSA/COUNT Configuration (1OEAB = 2OEAB = 0, 1OEBA = 2OEBA = 0)

PRODUCT PREVIEW

timing description

All test operations of the 'LVTH18652A and 'LVTH182652A are synchronous to the TCK signal. Data on the TDI, TMS, and normal-function inputs is captured on the rising edge of TCK. Data appears on the TDO and normal-function output pins on the falling edge of TCK. The TAP controller is advanced through its states (as shown in Figure 2) by changing the value of TMS on the falling edge of TCK and then applying a rising edge to TCK.

A simple timing example is shown in Figure 14. In this example, the TAP controller begins in the Test-Logic-Reset state and is advanced through its states as necessary to perform one instruction-register scan and one data-register scan. While in the Shift-IR and Shift-DR states, TDI is used to input serial data, and TDO is used to output serial data. The TAP controller is then returned to the Test-Logic-Reset state. Table 5 explains the operation of the test circuitry during each TCK cycle.

Table 5. Explanation of Timing Example

TCK CYCLE(S)	TAP STATE AFTER TCK	DESCRIPTION
1	Test-Logic-Reset	TMS is changed to a logic 0 value on the falling edge of TCK to begin advancing the TAP controller toward the desired state.
2	Run-Test/Idle	
3	Select-DR-Scan	
4	Select-IR-Scan	
5	Capture-IR	The IR captures the 8-bit binary value 10000001 on the rising edge of TCK as the TAP controller exits the Capture-IR state.
6	Shift-IR	TDO becomes active and TDI is made valid on the falling edge of TCK. The first bit is shifted into the TAP on the rising edge of TCK as the TAP controller advances to the next state.
7–13	Shift-IR	One bit is shifted into the IR on each TCK rising edge. With TDI held at a logic 1 value, the 8-bit binary value 11111111 is serially scanned into the IR. At the same time, the 8-bit binary value 10000001 is serially scanned out of the IR via TDO. In TCK cycle 13, TMS is changed to a logic 1 value to end the IR scan on the next TCK cycle. The last bit of the instruction is shifted as the TAP controller advances from Shift-IR to Exit1-IR.
14	Exit1-IR	TDO becomes inactive (goes to the high-impedance state) on the falling edge of TCK.
15	Update-IR	The IR is updated with the new instruction (BYPASS) on the falling edge of TCK.
16	Select-DR-Scan	
17	Capture-DR	The bypass register captures a logic 0 value on the rising edge of TCK as the TAP controller exits the Capture-DR state.
18	Shift-DR	TDO becomes active and TDI is made valid on the falling edge of TCK. The first bit is shifted into the TAP on the rising edge of TCK as the TAP controller advances to the next state.
19–20	Shift-DR	The binary value 101 is shifted in via TDI, while the binary value 010 is shifted out via TDO.
21	Exit1-DR	TDO becomes inactive (goes to the high-impedance state) on the falling edge of TCK.
22	Update-DR	In general, the selected data register is updated with the new data on the falling edge of TCK.
23	Select-DR-Scan	
24	Select-IR-Scan	
25	Test-Logic-Reset	Test operation completed

PRODUCT PREVIEW



SN54LVTH18652A, SN54LVTH182652A, SN74LVTH18652A, SN74LVTH182652A
3.3-V ABT SCAN TEST DEVICES
WITH 18-BIT TRANSCEIVERS AND REGISTERS

SCBS312B – MARCH 1994 – REVISED JULY 1996

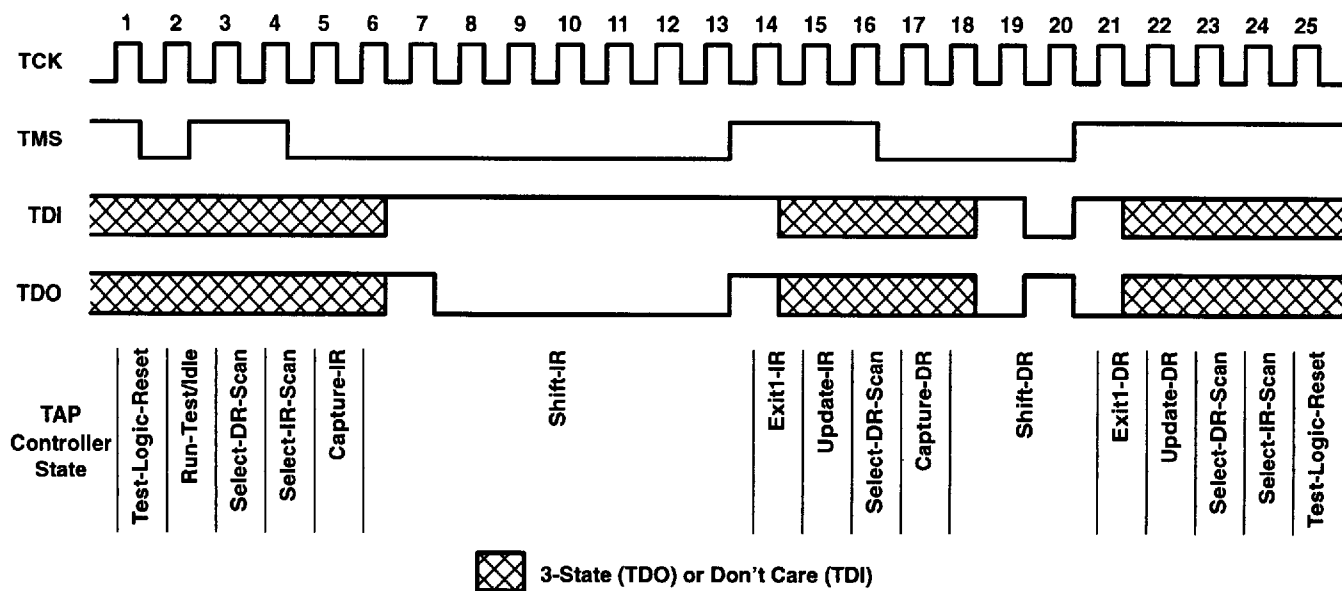

Figure 14. Timing Example

absolute maximum ratings over operating free-air temperature range (unless otherwise noted)†

Supply voltage range, V_{CC}	-0.5 V to 4.6 V
Input voltage range, V_I (see Note 1)	-0.5 V to 7 V
Voltage range applied to any output in the high state or power-off state, V_O (see Note 1)	-0.5 V to 7 V
Current into any output in the low state, I_O : SN54LVTH18652A	96 mA
SN54LVTH182652A (A port or TDO)	96 mA
SN54LVTH182652A (B port)	30 mA
SN74LVTH18652A	128 mA
SN74LVTH182652A (A port or TDO)	128 mA
SN74LVTH182652A (B port)	30 mA
Current into any output in the high state, I_O (see Note 2): SN54LVTH18652A	48 mA
SN54LVTH182652A (A port or TDO)	48 mA
SN54LVTH182652A (B port)	30 mA
SN74LVTH18652A	64 mA
SN74LVTH182652A (A port or TDO)	64 mA
SN74LVTH182652A (B port)	30 mA
Input clamp current, I_{IK} ($V_I < 0$)	-50 mA
Output clamp current, I_{OK} ($V_O < 0$)	-50 mA
Maximum power dissipation at $T_A = 55^\circ\text{C}$ (in still air) (see Note 3): PM package	1 W
Storage temperature range, T_{stg}	-65°C to 150°C

† Stresses beyond those listed under "absolute maximum ratings" may cause permanent damage to the device. These are stress ratings only, and functional operation of the device at these or any other conditions beyond those indicated under "recommended operating conditions" is not implied. Exposure to absolute-maximum-rated conditions for extended periods may affect device reliability.

NOTES: 1. The input and output negative-voltage ratings can be exceeded if the input and output clamp-current ratings are observed.

2. This current will only flow when the output is in the high state and $V_O > V_{CC}$.

3. The maximum package power dissipation is calculated using a junction temperature of 150°C and a board trace length of 75 mils.

For more information, refer to the *Package Thermal Considerations* application note in the *ABT Advanced BiCMOS Technology Data Book*, literature number SCBD002.

PRODUCT PREVIEW



POST OFFICE BOX 655303 • DALLAS, TEXAS 75265

SN54LVTH18652A, SN54LVTH182652A, SN74LVTH18652A, SN74LVTH182652A
3.3-V ABT SCAN TEST DEVICES
WITH 18-BIT TRANSCEIVERS AND REGISTERS
SCBS312B – MARCH 1994 – REVISED JULY 1996

recommended operating conditions

		SN54LVTH18652A		SN74LVTH18652A		UNIT
		MIN	MAX	MIN	MAX	
V _{CC}	Supply voltage	2.7	3.6	2.7	3.6	V
V _{IH}	High-level input voltage	2		2		V
V _{IL}	Low-level input voltage		0.8		0.8	V
V _I	Input voltage		5.5		5.5	V
I _{OH}	High-level output current		-24		-32	mA
I _{OL}	Low-level output current		24		32	mA
I _{OL} [†]	Low-level output current		48		64	mA
Δt/Δv	Input transition rise or fall rate	Outputs enabled		10	10	ns/V
T _A	Operating free-air temperature	-55	125	-40	85	°C

† Current duty cycle ≤ 50%, f ≥ 1 kHz

PRODUCT PREVIEW



SN54LVTH18652A, SN54LVTH182652A, SN74LVTH18652A, SN74LVTH182652A
 3.3-V ABT SCAN TEST DEVICES
 WITH 18-BIT TRANSCEIVERS AND REGISTERS

SCBS312B – MARCH 1994 – REVISED JULY 1996

electrical characteristics over recommended operating free-air temperature range (unless otherwise noted) (see Note 4)

PARAMETER	TEST CONDITIONS		SN54LVTH18652A		SN74LVTH18652A		UNIT	
			MIN	TYP†	MAX	MIN		TYP†
V_{IK}	$V_{CC} = 2.7\text{ V}$, $I_I = -18\text{ mA}$		-1.2		-1.2		V	
V_{OH}	$V_{CC} = \text{MIN to MAX}^\ddagger$, $I_{OH} = -100\ \mu\text{A}$		$V_{CC} - 0.2$		$V_{CC} - 0.2$		V	
	$V_{CC} = 2.7\text{ V}$, $I_{OH} = -3\text{ mA}$		2.4		2.4			
	$V_{CC} = 3\text{ V}$	$I_{OH} = -8\text{ mA}$	2.4		2.4			
		$I_{OH} = -24\text{ mA}$	2					
V_{OL}	$V_{CC} = 2.7\text{ V}$	$I_{OL} = 100\ \mu\text{A}$	0.2		0.2		V	
		$I_{OL} = 24\text{ mA}$	0.5		0.5			
	$V_{CC} = 3\text{ V}$	$I_{OL} = 16\text{ mA}$	0.4		0.4			
		$I_{OL} = 32\text{ mA}$	0.5		0.5			
		$I_{OL} = 48\text{ mA}$	0.55					
		$I_{OL} = 64\text{ mA}$			0.55			
I_I	$V_{CC} = 3.6\text{ V}$, $V_I = V_{CC}$ or GND		CLK, S, TCK	± 1		± 1		μA
	$V_{CC} = 0$ or MAX^\ddagger , $V_I = 5.5\text{ V}$			10		10		
	$V_{CC} = 3.6\text{ V}$	$V_I = 5.5\text{ V}$	OEBA, TDI, TMS	50		50		μA
		$V_I = V_{CC}$		1		1		
		$V_I = 0$		-25		-100		
		$V_I = 5.5\text{ V}$		35		150		
		$V_I = V_{CC}$	OEAB	25		100		μA
		$V_I = 0$		-5		-5		
		$V_I = 5.5\text{ V}$	A or B ports§	20		20		μA
		$V_I = V_{CC}$		1		1		
	$V_I = 0$	-5		-5				
	I_{off}	$V_{CC} = 0$, V_I or $V_O = 0$ to 4.5 V				± 100		μA
$I_I(\text{hold})^\parallel$	$V_{CC} = 3\text{ V}$	$V_I = 0.8\text{ V}$	75		75		μA	
		$V_I = 2\text{ V}$	-75		-75			
I_{OZH}	$V_{CC} = 3.6\text{ V}$, $V_O = 3\text{ V}$		1		1		μA	
I_{OZL}	$V_{CC} = 3.6\text{ V}$, $V_O = 0.5\text{ V}$		-1		-1		μA	
I_{OZPU}	$V_{CC} = 0$ to 1.5 V , $V_O = 0.5\text{ V}$ or 3 V		± 50		± 50		μA	
I_{OZPD}	$V_{CC} = 1.5\text{ V}$ to 0 , $V_O = 0.5\text{ V}$ or 3 V		± 50		± 50		μA	
I_{CC}	$V_{CC} = 3.6\text{ V}$, $I_O = 0$, $V_I = V_{CC}$ or GND		Outputs high	2		2		mA
			Outputs low	30		30		
			Outputs disabled	2		2		
$\Delta I_{CC}^\#$	$V_{CC} = 3\text{ V}$ to 3.6 V , One input at $V_{CC} - 0.6\text{ V}$, Other inputs at V_{CC} or GND		0.2		0.2		mA	
C_i	$V_I = 3\text{ V}$ or 0		4		4		pF	
C_{iO}	$V_O = 3\text{ V}$ or 0		11		11		pF	
C_o	$V_O = 3\text{ V}$ or 0		8		8		pF	

† All typical values are at $V_{CC} = 3.3\text{ V}$, $T_A = 25^\circ\text{C}$.

‡ For conditions shown as MIN or MAX, use the appropriate value specified under recommended operating conditions.

§ Unused pins at V_{CC} or GND

¶ The parameter $I_I(\text{hold})$ includes the off-state output leakage current.

This is the increase in supply current for each input that is at the specified TTL voltage level rather than V_{CC} or GND.

NOTE 4: Product preview specifications are design goals only and are subject to change without notice.

PRODUCT PREVIEW



POST OFFICE BOX 655303 • DALLAS, TEXAS 75265

SN54LVTH18652A, SN54LVTH182652A, SN74LVTH18652A, SN74LVTH182652A
3.3-V ABT SCAN TEST DEVICES
WITH 18-BIT TRANSCEIVERS AND REGISTERS

SCBS312B – MARCH 1994 – REVISED JULY 1996

timing requirements over recommended operating free-air temperature range (unless otherwise noted) (normal mode) (see Note 4 and Figure 15)

			SN54LVTH18652A				SN74LVTH18652A				UNIT
			$V_{CC} = 3.3\text{ V} \pm 0.3\text{ V}$		$V_{CC} = 2.7\text{ V}$		$V_{CC} = 3.3\text{ V} \pm 0.3\text{ V}$		$V_{CC} = 2.7\text{ V}$		
			MIN	MAX	MIN	MAX	MIN	MAX	MIN	MAX	
f_{clock}	Clock frequency	CLKAB or CLKBA				0	100			MHz	
t_w	Pulse duration	CLKAB or CLKBA high or low				5				ns	
t_{su}	Setup time	A before CLKAB \uparrow or B before CLKBA \uparrow				4				ns	
t_h	Hold time	A after CLKAB \uparrow or B after CLKBA \uparrow				1				ns	

timing requirements over recommended operating free-air temperature range (unless otherwise noted) (test mode) (see Note 4 and Figure 15)

			SN54LVTH18652A				SN74LVTH18652A				UNIT
			$V_{CC} = 3.3\text{ V} \pm 0.3\text{ V}$		$V_{CC} = 2.7\text{ V}$		$V_{CC} = 3.3\text{ V} \pm 0.3\text{ V}$		$V_{CC} = 2.7\text{ V}$		
			MIN	MAX	MIN	MAX	MIN	MAX	MIN	MAX	
f_{clock}	Clock frequency	TCK				0	50			MHz	
t_w	Pulse duration	TCK high or low				9.5				ns	
t_{su}	Setup time	A, B, CLK, OEAB, OEBA or S before TCK \uparrow				6.5				ns	
		TDI before TCK \uparrow				2.5					
		TMS before TCK \uparrow				2.5					
t_h	Hold time	A, B, CLK, OEAB, OEBA or S after TCK \uparrow				1.5				ns	
		TDI after TCK \uparrow				1.5					
		TMS after TCK \uparrow				1.5					
t_d	Delay time	Power up to TCK \uparrow				50				ns	
t_r	Rise time	V_{CC} power up				1				μs	

NOTE 4: Product preview specifications are design goals only and are subject to change without notice.

PRODUCT PREVIEW



switching characteristics over recommended operating free-air temperature range (unless otherwise noted) (normal mode) (see Note 4 and Figure 15)

PARAMETER	FROM (INPUT)	TO (OUTPUT)	SN54LVTH18652A				SN74LVTH18652A				UNIT
			V _{CC} = 3.3 V ± 0.3 V		V _{CC} = 2.7 V		V _{CC} = 3.3 V ± 0.3 V		V _{CC} = 2.7 V		
			MIN	MAX	MIN	MAX	MIN	MAX	MIN	MAX	
f _{max}	CLKAB or CLKBA							100			MHz
t _{PLH}	A or B	B or A					1.5	6			ns
t _{PHL}							1.5	6			
t _{PLH}	CLKAB or CLKBA	B or A					1.5	7			ns
t _{PHL}							1.5	7			
t _{PLH}	SAB or SBA	B or A					1.5	8			ns
t _{PHL}							1.5	8			
t _{PZH}	OEAB or OEBA	B or A					2	10			ns
t _{PZL}							2	10			
t _{PHZ}	OEAB or OEBA	B or A					1.5	11			ns
t _{PLZ}							1.5	11			

switching characteristics over recommended operating free-air temperature range (unless otherwise noted) (test mode) (see Note 4 and Figure 15)

PARAMETER	FROM (INPUT)	TO (OUTPUT)	SN54LVTH18652A				SN74LVTH18652A				UNIT
			V _{CC} = 3.3 V ± 0.3 V		V _{CC} = 2.7 V		V _{CC} = 3.3 V ± 0.3 V		V _{CC} = 2.7 V		
			MIN	MAX	MIN	MAX	MIN	MAX	MIN	MAX	
f _{max}	TCK							50			MHz
t _{PLH}	TCK↓	A or B						2.5	15		ns
t _{PHL}							2.5	15			
t _{PLH}	TCK↓	TDO						1.5	7		ns
t _{PHL}							1.5	7			
t _{PZH}	TCK↓	A or B						3	18		ns
t _{PZL}							3	18			
t _{PZH}	TCK↓	TDO						1.5	7		ns
t _{PZL}							1.5	7			
t _{PHZ}	TCK↓	A or B						3	19		ns
t _{PLZ}							3	19			
t _{PHZ}	TCK↓	TDO						1.5	8		ns
t _{PLZ}							1.5	8			

NOTE 4: Product preview specifications are design goals only and are subject to change without notice.

PRODUCT PREVIEW



SN54LVTH18652A, SN54LVTH182652A, SN74LVTH18652A, SN74LVTH182652A
3.3-V ABT SCAN TEST DEVICES
WITH 18-BIT TRANSCEIVERS AND REGISTERS

SCBS312B – MARCH 1994 – REVISED JULY 1996

recommended operating conditions

		SN54LVTH182652A		SN74LVTH182652A		UNIT
		MIN	MAX	MIN	MAX	
V _{CC}	Supply voltage	2.7	3.6	2.7	3.6	V
V _{IH}	High-level input voltage	2		2		V
V _{IL}	Low-level input voltage		0.8		0.8	V
V _I	Input voltage		5.5		5.5	V
I _{OH}	High-level output current	A port, TDO		-32		mA
		B port		-12		
I _{OL}	Low-level output current	A port, TDO		32		mA
		B port		12		
I _{OL} [†]	Low-level output current	A port, TDO		64		mA
ΔV/Δv	Input transition rise or fall rate	Outputs enabled		10		ns/V
T _A	Operating free-air temperature	-55	125	-40	85	°C

† Current duty cycle ≤ 50%, f ≥ 1 kHz

PRODUCT PREVIEW



electrical characteristics over recommended operating free-air temperature range (unless otherwise noted) (see Note 4)

PARAMETER	TEST CONDITIONS		SN54LVTH182652A		SN74LVTH182652A		UNIT	
			MIN	TYP†	MAX	MIN		TYP†
V_{IK}	$V_{CC} = 2.7\text{ V}$, $I_I = -18\text{ mA}$		-1.2		-1.2		V	
V_{OH}	$V_{CC} = \text{MIN to MAX}^\ddagger$, $I_{OH} = -100\ \mu\text{A}$		$V_{CC} - 0.2$		$V_{CC} - 0.2$		V	
	$V_{CC} = 2.7\text{ V}$, $I_{OH} = -3\text{ mA}$		2.4		2.4			
	$V_{CC} = 3\text{ V}$	A port, TDO	$I_{OH} = -8\text{ mA}$	2.4		2.4		
			$I_{OH} = -24\text{ mA}$	2				
			$I_{OH} = -32\text{ mA}$			2		
	B port	$I_{OH} = -12\text{ mA}$	2		2			
V_{OL}	$V_{CC} = 2.7\text{ V}$	A port, TDO	$I_{OL} = 100\ \mu\text{A}$	0.2		0.2		
			$I_{OL} = 24\text{ mA}$	0.5		0.5		
	$V_{CC} = 3\text{ V}$	A port, TDO	$I_{OL} = 16\text{ mA}$	0.4		0.4		
			$I_{OL} = 32\text{ mA}$	0.5		0.5		
			$I_{OL} = 48\text{ mA}$	0.55				
			$I_{OL} = 64\text{ mA}$			0.55		
		B port	$I_{OL} = 12\text{ mA}$	0.8		0.8		
I_I	$V_{CC} = 3.6\text{ V}$, $V_I = V_{CC}$ or GND		±1		±1		μA	
	$V_{CC} = 0$ or MAX^\ddagger , $V_I = 5.5\text{ V}$		10		10			
	$V_{CC} = 3.6\text{ V}$	CLK, S, TCK	$V_I = 5.5\text{ V}$	50		50		
			$V_I = V_{CC}$	1		1		
		OEBA, TDI, TMS	$V_I = 0$	-25		-100		
			$V_I = 5.5\text{ V}$	35		150		
			$V_I = V_{CC}$	25		100		
			$V_I = 0$	-5		-5		
		OEAB	$V_I = 5.5\text{ V}$	20		20		
			$V_I = V_{CC}$	1		1		
$V_I = 0$	-5		-5					
I_{off}	$V_{CC} = 0$, V_I or $V_O = 0$ to 4.5 V				±100			
	$V_{CC} = 3\text{ V}$	A or B ports	$V_I = 0.8\text{ V}$	75		75		
$V_I = 2\text{ V}$			-75		-75			
I_{OZH}	$V_{CC} = 3.6\text{ V}$, $V_O = 3\text{ V}$	TDO	1		1			
I_{OZL}	$V_{CC} = 3.6\text{ V}$, $V_O = 0.5\text{ V}$	TDO	-1		-1			
I_{OZPU}	$V_{CC} = 0$ to 1.5 V, $V_O = 0.5\text{ V}$ or 3 V	TDO	±50		±50			
I_{OZPD}	$V_{CC} = 1.5\text{ V}$ to 0, $V_O = 0.5\text{ V}$ or 3 V	TDO	±50		±50			
I_{CC}	$V_{CC} = 3.6\text{ V}$, $I_O = 0$, $V_I = V_{CC}$ or GND		Outputs high	2		2		
			Outputs low	35		35		
			Outputs disabled	2		2		
$\Delta I_{CC}^\#$	$V_{CC} = 3\text{ V}$ to 3.6 V, One input at $V_{CC} - 0.6\text{ V}$, Other inputs at V_{CC} or GND		0.2		0.2			

† All typical values are at $V_{CC} = 3.3\text{ V}$, $T_A = 25^\circ\text{C}$.

‡ For conditions shown as MIN or MAX, use the appropriate value specified under recommended operating conditions.

§ Unused pins at V_{CC} or GND

¶ The parameter $I_I(\text{hold})$ includes the off-state output current.

This is the increase in supply current for each input that is at the specified TTL voltage level rather than V_{CC} or GND.

NOTE 4: Product preview specifications are design goals only and are subject to change without notice.



PRODUCT PREVIEW

SN54LVTH18652A, SN54LVTH182652A, SN74LVTH18652A, SN74LVTH182652A
3.3-V ABT SCAN TEST DEVICES
WITH 18-BIT TRANSCEIVERS AND REGISTERS

SCBS312B – MARCH 1994 – REVISED JULY 1996

electrical characteristics over recommended operating free-air temperature range (unless otherwise noted) (see Note 4)

PARAMETER	TEST CONDITIONS	SN54LVTH182652A		SN74LVTH182652A		UNIT
		MIN	TYP†	MAX	MIN	
C _i	V _I = 3 V or 0		4		4	pF
C _{io}	V _O = 3 V or 0		11		11	pF
C _O	V _O = 3 V or 0		8		8	pF

† All typical values are at V_{CC} = 3.3 V, T_A = 25°C.

NOTE 4: Product preview specifications are design goals only and are subject to change without notice.

timing requirements over recommended operating free-air temperature range (unless otherwise noted) (normal mode) (see Note 4 and Figure 15)

			SN54LVTH182652A		SN74LVTH182652A		UNIT				
			V _{CC} = 3.3 V ± 0.3 V		V _{CC} = 2.7 V			V _{CC} = 3.3 V ± 0.3 V		V _{CC} = 2.7 V	
			MIN	MAX	MIN	MAX		MIN	MAX	MIN	MAX
f _{clock}	Clock frequency	CLKAB or CLKBA				0	100			MHz	
t _w	Pulse duration	CLKAB or CLKBA high or low				5				ns	
t _{su}	Setup time	A before CLKAB↑ or B before CLKBA↑				4				ns	
t _h	Hold time	A after CLKAB↑ or B after CLKBA↑				1				ns	

timing requirements over recommended operating free-air temperature range (unless otherwise noted) (test mode) (see Note 4 and Figure 15)

			SN54LVTH182652A		SN74LVTH182652A		UNIT				
			V _{CC} = 3.3 V ± 0.3 V		V _{CC} = 2.7 V			V _{CC} = 3.3 V ± 0.3 V		V _{CC} = 2.7 V	
			MIN	MAX	MIN	MAX		MIN	MAX	MIN	MAX
f _{clock}	Clock frequency	TCK				0	50			MHz	
t _w	Pulse duration	TCK high or low				9.5				ns	
t _{su}	Setup time	A, B, CLK, OEAB, OEBA or S before TCK↑				6.5				ns	
		TDI before TCK↑				2.5					
		TMS before TCK↑				2.5					
t _h	Hold time	A, B, CLK, OEAB, OEBA or S after TCK↑				1.5				ns	
		TDI after TCK↑				1.5					
		TMS after TCK↑				1.5					
t _d	Delay time	Power up to TCK↑				50				ns	
t _r	Rise time	V _{CC} power up				1				μs	

NOTE 4: Product preview specifications are design goals only and are subject to change without notice.

PRODUCT PREVIEW



SN54LVTH18652A, SN54LVTH182652A, SN74LVTH18652A, SN74LVTH182652A

3.3-V ABT SCAN TEST DEVICES

WITH 18-BIT TRANSCEIVERS AND REGISTERS

SCBS312B – MARCH 1994 – REVISED JULY 1996

switching characteristics over recommended operating free-air temperature range (unless otherwise noted) (normal mode) (see Note 4 and Figure 15)

PARAMETER	FROM (INPUT)	TO (OUTPUT)	SN54LVTH182652A				SN74LVTH182652A				UNIT
			V _{CC} = 3.3 V ± 0.3 V		V _{CC} = 2.7 V		V _{CC} = 3.3 V ± 0.3 V		V _{CC} = 2.7 V		
			MIN	MAX	MIN	MAX	MIN	MAX	MIN	MAX	
f _{max}	CLKAB or CLKBA							100			MHz
t _{PLH}	A or B	B or A					1.5	7			ns
t _{PHL}							1.5	7			
t _{PLH}	CLKAB or CLKBA	B or A					1.5	8			ns
t _{PHL}							1.5	8			
t _{PLH}	SAB or SBA	B or A					1.5	9			ns
t _{PHL}							1.5	9			
t _{PZH}	OEAB or OEBA	B or A					2	11			ns
t _{PZL}							2	11			
t _{PHZ}	OEAB or OEBA	B or A					1.5	12			ns
t _{PLZ}							1.5	12			

switching characteristics over recommended operating free-air temperature range (unless otherwise noted) (test mode) (see Note 4 and Figure 15)

PARAMETER	FROM (INPUT)	TO (OUTPUT)	SN54LVTH182652A				SN74LVTH182652A				UNIT
			V _{CC} = 3.3 V ± 0.3 V		V _{CC} = 2.7 V		V _{CC} = 3.3 V ± 0.3 V		V _{CC} = 2.7 V		
			MIN	MAX	MIN	MAX	MIN	MAX	MIN	MAX	
f _{max}	TCK							50			MHz
t _{PLH}	TCK↓	A or B					2.5	15			ns
t _{PHL}							2.5	15			
t _{PLH}	TCK↓	TDO					1.5	7			ns
t _{PHL}							1.5	7			
t _{PZH}	TCK↓	A or B					3	18			ns
t _{PZL}							3	18			
t _{PZH}	TCK↓	TDO					1.5	7			ns
t _{PZL}							1.5	7			
t _{PHZ}	TCK↓	A or B					3	19			ns
t _{PLZ}							3	19			
t _{PHZ}	TCK↓	TDO					1.5	8			ns
t _{PLZ}							1.5	8			

NOTE 4: Product preview specifications are design goals only and are subject to change without notice.

PRODUCT PREVIEW



POST OFFICE BOX 655303 • DALLAS, TEXAS 75265

PARAMETER MEASUREMENT INFORMATION

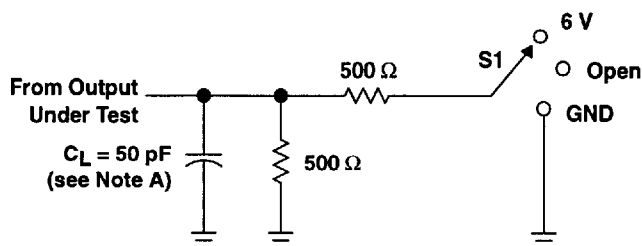

LOAD CIRCUIT

TEST	S1
t_{PLH}/t_{PHL}	Open
t_{PLZ}/t_{PZL}	6 V
t_{PHZ}/t_{PZH}	GND

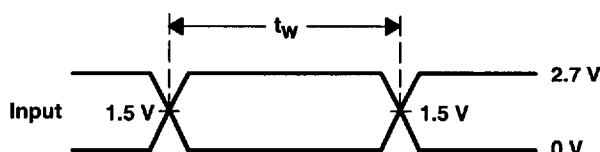

VOLTAGE WAVEFORMS
PULSE DURATION

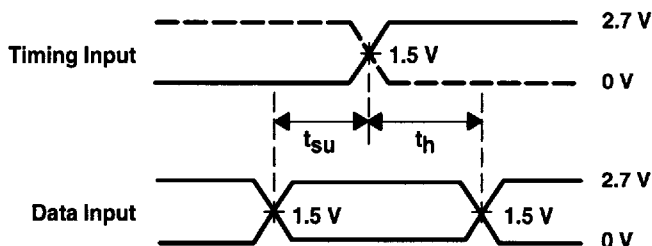

VOLTAGE WAVEFORMS
SETUP AND HOLD TIMES

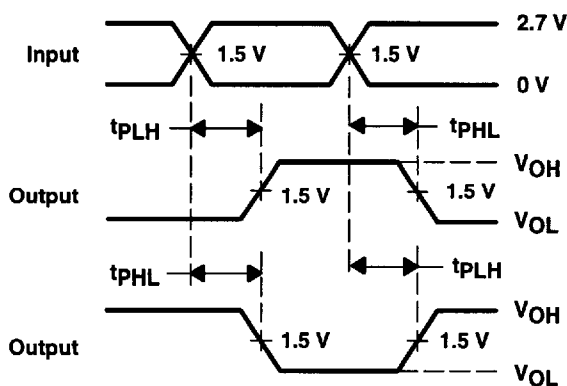

VOLTAGE WAVEFORMS
PROPAGATION DELAY TIMES
INVERTING AND NONINVERTING OUTPUTS

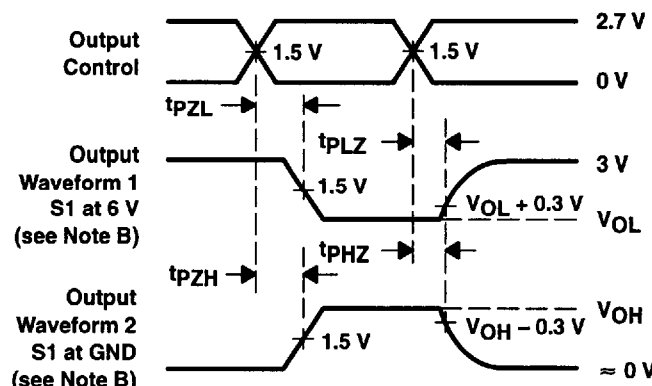

VOLTAGE WAVEFORMS
ENABLE AND DISABLE TIMES
LOW- AND HIGH-LEVEL ENABLING

- NOTES: A. C_L includes probe and jig capacitance.
 B. Waveform 1 is for an output with internal conditions such that the output is low except when disabled by the output control. Waveform 2 is for an output with internal conditions such that the output is high except when disabled by the output control.
 C. All input pulses are supplied by generators having the following characteristics: $PRR \leq 10$ MHz, $Z_O = 50 \Omega$, $t_r \leq 2.5$ ns, $t_f \leq 2.5$ ns.
 D. The outputs are measured one at a time with one transition per measurement.

Figure 15. Load Circuit and Voltage Waveforms

PRODUCT PREVIEW