

## Preliminary Information

This document contains information on a new product. The parametric information, although not fully characterized, is the result of testing initial devices.

## M02097-11/-21

### 3.3/5V LED Driver / Limiting Amplifier for Operation to 500 Mbps

The M02097 is an integrated LED driver and limiting amplifier for applications to 500 Mbps. The LED driver modulation output can be AC or DC coupled to an LED. The device can operate from a 3.3V or 5V supply.

The M02097 includes monitors for bias and modulation current. Integrated safety circuitry provides latched bias and modulation current shutdown if a fault condition is detected and provides an internal  $V_{CC}$  switch.

The limiting amplifier also includes a programmable signal-level detector, allowing the user to set thresholds at which the logic outputs are enabled. The M02097-11 features a PECL LOS-ST output while the M02097-21 features a CMOS (external pull-up required) LOS-ST output. PECL outputs are available on the limiting amplifier.

Configuration logic provides flexibility in setting data path polarity, safety logic configuration, and LOS behavior.

#### Applications

- 155Mbps LAN ATM Transceivers
- ESCON Receivers
- Fast Ethernet/FDDI
- Multimode LED Transmitters
- SFP Transceivers
- IEEE 1394 S100, S200 and S400 Transceivers

#### Features

- High speed operation; suitable for applications to 500 Mbps. 200 ps typical rise/fall time into  $5\Omega$ .
- Programmable modulation current to 120 mA
- Integrated power supply switch for redundant shutdown under a fault condition

#### Features (con't)

- Temperature compensation for modulation current
- Pre-bias adjustment to improve LED edge speed
- SFP compliant safety circuitry (configurable)
- 6mV input limiting amp sensitivity at 500 Mbps.
- PECL limiting amplifier outputs
- Limiting amplifier includes integrated DC offset cancellation circuit
- Polarity Control for both the driver and limiting amplifier data paths
- Operates with 3.3V or 5V supply with an internal auto-sensing regulator that enables with 5V supplies and is bypassed with 3.3V supplies
- Powers 3.3V ROSAs from its Receiver Regulator output enabling true 3.3/5V designs using all 3.3V Mindspeed TIAs

M02097 Block Diagram

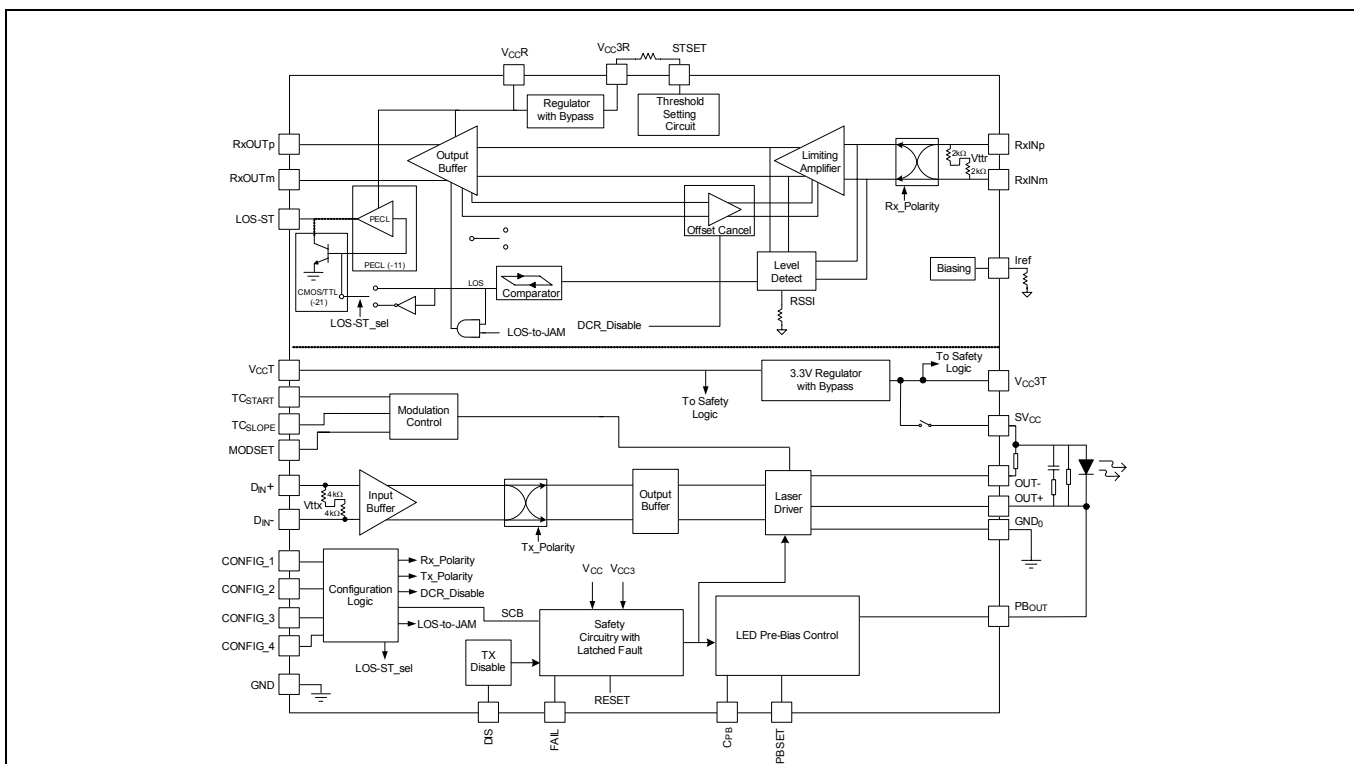

## Ordering Information

| Part Number | Package | Operating Temperature |
|-------------|---------|-----------------------|
| M02097G-11* | QFN32   | -40°C to 95°C         |
| M02097G-21* | QFN32   | -40°C to 95°C         |

\* The letter "G" designator after the part number indicates that the device is RoHS-compliant. Refer to [www.mindspeed.com](http://www.mindspeed.com) for additional information.

## Revision History

| Revision | Level       | Date          | ASIC Revision | Description   |
|----------|-------------|---------------|---------------|---|
| C        | Preliminary | November 2006 | -11/-21       | Reflect current device pinout.                                    |
| B        | Advance     | August 2006   | -11/-21       | Update several specifications based on initial device evaluation. |
| A        | Advance     | June 2006     | NA            | Initial Release.  |

Preliminary Information

**M02097 622 Mbps LED Driver Eye Diagram**

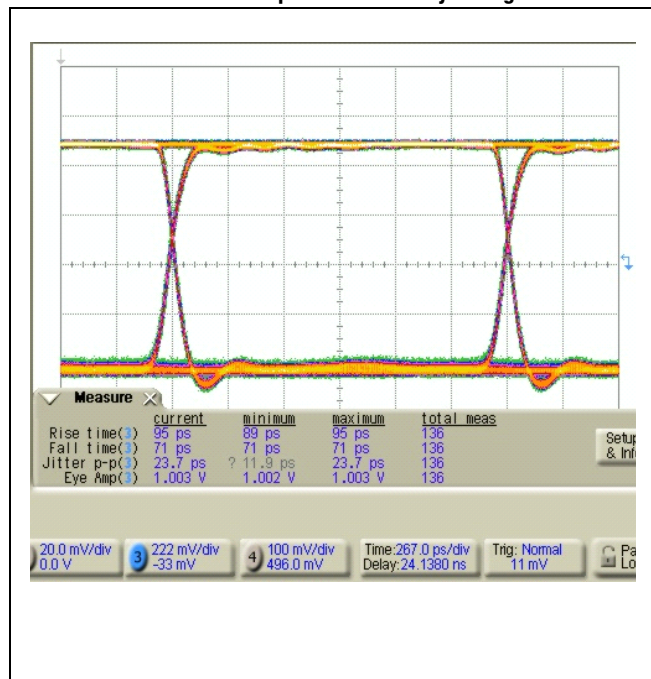

**M02097 Pin Configuration**

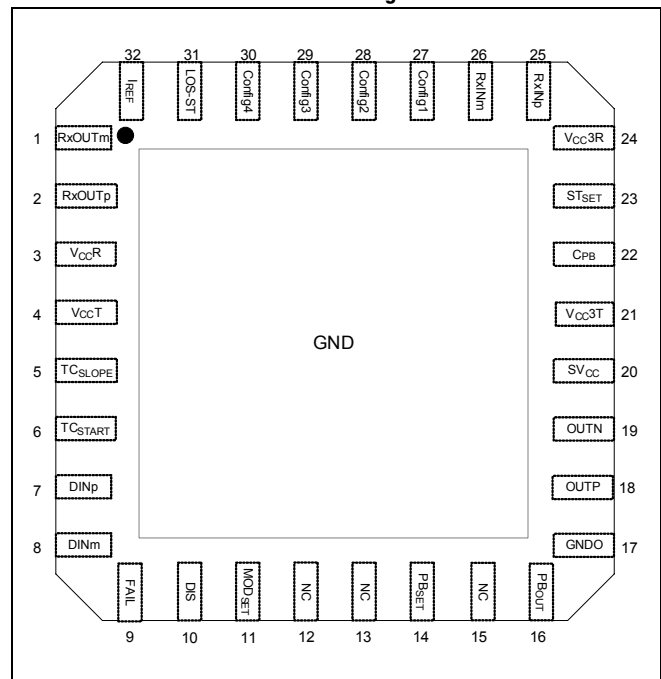



# 1.0 Product Specification

## 1.1 Absolute Maximum Ratings

These are the absolute maximum ratings at or beyond which the IC can be expected to fail or be damaged. Reliable operation at these extremes for any length of time is not implied.

**Table 1-1. Absolute Maximum Ratings**

| Symbol           | Parameter  | Rating       | Units |
|------------------|--|--------------|-------|
| $V_{CC}$         | Power supply voltage   | -0.4 to +6.5 | V     |
| $V_{CC3}$        | 3.3V power supply voltage (when $V_{CC3}$ is connected to $V_{CC}$ ) | -0.4 to +4.0 | V     |
| $T_A$            | Ambient operating temperature  | -40 to +95   | °C    |
| $T_{STG}$        | Storage temperature  | -65 to +150  | °C    |
| $IPB_{OUT\_MAX}$ | Maximum pre-bias output current at $PB_{OUT}$                        | 20           | mA    |
| $I_{MOD\_MAX}$   | Maximum modulation current   | 140          | mA    |

## 1.2 Recommended Operating Conditions

**Table 1-2. Recommended Operating Conditions**

| Parameter   | Rating                             | Units |
|---|------------------------------------|-------|
| Power supply: ( $V_{CC-GND}$ ) (apply no potential to $V_{CC3}$ ) or ( $V_{CC3-GND}$ ) (connect $V_{CC}$ to same potential as $V_{CC3}$ ) | +5V $\pm$ 7.5% or +3.3V $\pm$ 7.5% | V     |
| Junction temperature  | -40 to +125                        | °C    |
| Operating ambient   | -40 to +95                         | °C    |

Preliminary Information

## 1.3 DC Characteristics

### 1.3.1 DC Electrical Characteristics - LED Driver

$V_{CC} = 3.05$  to  $3.55V$  or  $4.7$  to  $5.5V$ ,  $T_A = -40^{\circ}C$  to  $+95^{\circ}C$ , unless otherwise noted.  
 Typical values are  $V_{CC} = 3.3V$ ,  $I_{PBOUT} = 4mA$ ,  $I_{MOD} = 50mA$ .

**Table 1-3. DC Electrical Characteristics - LED Driver**

| Symbol           | Parameter   | Conditions   | Minimum        | Typical | Maximum | Units      |
|------------------|---|--|----------------|---------|---------|------------|
| $I_{CC}$         | $V_{CC}T$ supply current  | Using external 3.3V supply $V_{CC} = 3.3V$ <sup>(1)</sup>  | –              | 34      | 43      | mA         |
|                  |   | Additional current when operating from 5V supply           | –              | 1.5     | –       |            |
| $V_{CC3THL}$     | 3.3V supply detection (low voltage) threshold <sup>(3)</sup>  |  | 2.6            | 2.8     | 3.0     | V          |
| $V_{CC3HH}$      | 3.3V supply detection (high voltage) threshold <sup>(3)</sup>                                       |  | 3.65           | 3.8     | 4.1     | V          |
| $V_{CC5THL}$     | 5V supply detection (low voltage) threshold   |  | 4.3            | 4.45    | 4.65    | V          |
| $V_{CC5THH}$     | 5V supply detection (high voltage) threshold  |  | 5.6            | 6.0     | 6.2     | V          |
| $V_{MODSET}$     | Modulation current ref.   | Voltage reference for $MOD_{SET}$                          | 1.1            | 1.25    | 1.4     | V          |
| $V_{PBSET}$      | Pre-bias current setting output voltage reference   | Voltage at $PB_{SET}$                                      | 1.1            | 1.25    | 1.4     | V          |
| $V_{FAULTL}$     | Low fault voltage detection threshold ( $I_{BOUT}$ , $OUTP$ , $C_{PB}$ , $MOD_{SET}$ , $PB_{SET}$ ) | Fault condition occurs when voltage drops below this level | –              | 100     | 200     | mV         |
| $V_{SELFL}$      | Self-biased voltage for $PB_{OUT}$ and $OUTP$   | During disable condition                                   | 0.5            | 1.6     | 1.8     | V          |
| $I_{PRE-BIAS}$   | Pre-bias current adjust range   | At $PB_{OUT}$ : $V_{PBOUT} > 0.7V$                         | 1              | –       | 10      | mA         |
| $I_{PBIAS(OFF)}$ | Pre-bias current with output disabled   | $DIS = high$<br>$V_{PBOUT} = V_{CC3}$                      | –              | –       | 150     | $\mu A$    |
|                  | Ratio of pre-bias output current to $PB_{SET}$ current  | $= I_{PRE-BIAS} / I_{PBSET}$                               | –              | 60      | –       | A/A        |
| $V_{IH\_DIS}$    | TTL/CMOS input high voltage (DIS)   |  | 2.0            | –       | 5.5     | V          |
| $V_{IL\_DIS}$    | TTL/CMOS input low voltage (DIS)  |  | –              | –       | 0.8     | V          |
| $V_{IH\_CFG}$    | Configuration logic input high voltage (Config1 - 4) <sup>(4)</sup>                                 |  | $V_{CC3T-0.5}$ | –       | –       | V          |
| $V_{IL\_CFG}$    | Configuration logic input low voltage (Config1 - 4) <sup>(4)</sup>                                  |  | –              | –       | 0.5     | V          |
| $VOH\_FAIL$      | Logic output high voltage (FAIL)  | With external 10 k $\Omega$ pull-up to $V_{CC}$            | $V_{CC} - 0.6$ | –       | –       | V          |
| $VOL\_FAIL$      | Logic output low voltage (FAIL)   | $I_{OL} = 0.8 mA$  | –              | –       | 0.4     | V          |
| $R_{IN}$         | Differential input resistance   | Transmitter Data inputs                                    | –              | 6       | –       | k $\Omega$ |

Preliminary Information

**Table 1-3. DC Electrical Characteristics - LED Driver**

| Symbol                | Parameter                             | Conditions  | Minimum                | Typical                | Maximum  | Units |
|-----------------------|---------------------------------------|---|------------------------|------------------------|--|-------|
| V <sub>CMSELF</sub>   | Self-biased common mode input voltage | Data inputs floating                              | –                      | V <sub>CC3</sub> - 1.3 | –  | V     |
| V <sub>INCM</sub>     | Common-mode input compliance voltage  | Transmitter Data inputs                           | V <sub>CC3</sub> - 1.5 | –                      | V <sub>CC3</sub><br>- V <sub>IN(Diff)</sub> /4 | V     |
| V <sub>IN(Diff)</sub> | Differential input voltage            | = 2*(DIN <sub>pHIGH</sub> - DIN <sub>pLOW</sub> ) | 300                    | –                      | 2400   | mV    |

**NOTES:**

1. Excludes pre-bias and modulation currents delivered to the LED. Maximum supply current based on I<sub>MOD</sub> = 90 mA, I<sub>PBOUT</sub> = 10 mA.
2. Pre-bias and modulation currents add directly to power supply current in 5V applications; additional supply current noted excludes these currents.
3. V<sub>CC3</sub> supply okay circuitry monitors internally regulated voltage when only the +5V supply is used (V<sub>CC</sub> = 5V).
4. Input is 3.3V tolerant logic.

**1.3.2 DC Electrical Characteristics - Limiting Amplifier**

V<sub>CCR</sub> = 3.05 to 3.55V or 4.7 to 5.5V, T<sub>A</sub> = -40°C to +95°C, unless otherwise noted.  
 Typical values are V<sub>CC</sub> = 3.3V, 25°C.

**Table 1-4. DC Electrical Characteristics - Limiting Amplifier**

| Symbol                                  | Parameter                                       | Conditions   | Minimum                | Typical                 | Maximum                | Units |
|---|---|--|------------------------|-------------------------|------------------------|-------|
| I <sub>CC</sub>                         | V <sub>CCR</sub> supply current                 | Includes PECL load<br><br>Additional current when operating from 5V supply | –<br>–                 | 54<br>1.5               | 65<br>–                | mA    |
| V <sub>OUTLPECL</sub> <sup>(1)</sup>    | PECL Output Low Voltage (RxOUTm, RxOUTp)        | Single ended; 50Ω load to V <sub>CC</sub> - 2V                             | V <sub>CC</sub> - 1.86 | V <sub>CC</sub> - 1.71  | V <sub>CC</sub> - 1.62 | V     |
| V <sub>OUTHPECL</sub> <sup>(1)</sup>    | PECL Output High Voltage (RxOUTm, RxOUTp)       | Single ended; 50Ω load to V <sub>CC</sub> - 2V                             | V <sub>CC</sub> - 1.06 | V <sub>CC</sub> - 0.95  | V <sub>CC</sub> - 0.88 | V     |
| R <sub>IN_DIFF</sub>                    | Differential Input Resistance                   |  | –                      | 4                       | –                      | kΩ    |
| V <sub>OUTLLOSPECL</sub> <sup>(1)</sup> | LOS Output High Voltage <sup>(2)</sup>          | Open collector, 4.7 - 10 kΩ pull up to V <sub>CC</sub>                     | 2.4                    | –                       | V <sub>CC</sub>        | V     |
| V <sub>OUTHLOSPECL</sub> <sup>(1)</sup> | LOS Output Low Voltage <sup>(2)</sup>           | I <sub>OL</sub> = 0.8 mA   | –                      | –                       | 0.4                    | V     |
| V <sub>OUTLLOSCMOS</sub>                | LOS-ST Output Low Voltage <sup>(1, 2, 3)</sup>  | Single ended; 50Ω load to V <sub>CC</sub> - 2V                             | V <sub>CC</sub> - 1.9  | V <sub>CC</sub> - 1.78  | V <sub>CC</sub> - 1.66 | V     |
| V <sub>OUTHLOSCMOS</sub>                | LOS-ST Output High Voltage <sup>(1, 2, 3)</sup> | Single ended; 50Ω load to V <sub>CC</sub> - 2V                             | V <sub>CC</sub> - 1.13 | V <sub>CC</sub> - 1.042 | V <sub>CC</sub> - 0.95 | V     |

**NOTES:**

1. PECL level requirements apply from 0°C to 95°C.
2. M02091-11 has PECL LOS-ST output, M02097-21 has CMOS LOS-ST output.
3. When LOS-ST is terminated with a 510Ω resistor to ground, PECL output high and low levels are approximately the same as for V<sub>OUTHPECL</sub> and V<sub>OUTLPECL</sub>.

Preliminary Information

## 1.4 AC Characteristics

### 1.4.1 AC Electrical Characteristics - LED Driver

$V_{CCT} = 3.05$  to  $3.55V$  or  $4.7$  to  $5.5V$ ,  $T_A = -40^{\circ}C$  to  $+95^{\circ}C$ , unless otherwise noted.  
 Typical values are  $V_{CC} = 3.3V$ ,  $I_{PBOUT} = 4mA$ ,  $I_{MOD} = 50mA$ .

**Table 1-5. AC Electrical Characteristics - LED Driver**

| Symbol         | Parameter  | Conditions   | Minimum     | Typical | Maximum | Units            |
|----------------|--|--|-------------|---------|---------|------------------|
| $I_{MOD}$      | Modulation current adjust range  | To meet AC specifications  | 30          | –       | 120     | $mA_{PP}$        |
| $I_{MOD(OFF)}$ | Modulation current with output disabled                                      | DIS = high   | –           | –       | 150     | $\mu A$          |
|                | Ratio of modulation current to $MOD_{SET}$ current                           |  | –           | 140     | –       | A/A              |
| $I_{MOD-TC}$   | Programmable range for modulation current temperature coefficient            | Adjustable using $TC_{SLOPE}$  | 0           | –       | $10^4$  | ppm/ $^{\circ}C$ |
| $T_{TCSTRT}$   | Programmable temperature at which modulation current TC compensation enables | Based on value set for $TC_{START}$  | $-40^{(2)}$ | –       | 95      | $^{\circ}C$      |
| $t_R / t_F$    | Modulation output rise / fall times  | 20% to 80%. Measured using alternating 1111-0000 pattern at 500 Mbps; $5\Omega$ load with 12pF/35 $\Omega$ between OUTP and OUTN | –           | 200     | 500     | ps               |
| OS             | Overshoot of modulation output   | Into $5\Omega$ load with 12pF/35 $\Omega$ between OUTP and OUTN  | –           | 10      | –       | %                |
| RJ             | Random jitter  |  | –           | 0.8     | –       | $ps_{RMS}$       |
| DJ             | Modulation output deterministic jitter                                       | into $5\Omega$ load (includes pulse width distortion) $2^{23} - 1$ PRBS at 500 Mbps  | –           | 30      | 60      | $ps_{PP}$        |

**NOTES:**

1. Minimum voltage at OUTP > 0.7 V; LED forward voltage and total series resistance must be considered if output is DC coupled to LED.
2. Default if  $TC_{START}$  is floating.

Preliminary Information

### 1.4.2 AC Electrical Characteristics - Limiting Amplifier

V<sub>CCR</sub> = 3.05 to 3.55V or 4.7 to 5.5V, T<sub>A</sub> = -40°C to +95°C, unless otherwise noted.

**Table 1-6. AC Electrical Characteristics - Limiting Amplifier**

| Symbol                          | Parameter   | Conditions   | Minimum | Typical | Maximum | Units             |
|---------------------------------|---|--|---------|---------|---------|-------------------|
| V <sub>IN(MIN)</sub>            | Differential Input Sensitivity                        | BER < 10 <sup>-12</sup> at 1.25 Gbps with K28.5 pattern  | 2       | –       | –       | mV                |
| V <sub>I(MAX)</sub>             | Input Overload  | BER < 10 <sup>-12</sup> , differential input   | 1200    | –       | –       | mV                |
|                                 |   | BER < 10 <sup>-12</sup> , single-ended input   | 600     | –       | –       |                   |
| V <sub>N</sub>                  | RMS Input Referred Noise                              |  | –       | –       | 285     | μV <sub>RMS</sub> |
| V <sub>LOS</sub>                | LOS Programmable Range                                | Differential inputs, 6.0 kΩ ≤ R <sub>STSET</sub> ≤ 8.4 kΩ  | 5       | –       | 55      | mV                |
| HYS                             | Signal Detect Hysteresis                              | (electrical); signal detect level set to 20 mV <sub>PP</sub>   | 2       | 4       | 6       | dB                |
| RSSI <sub>pp</sub>              | Peak-to-peak received signal strength indicator range |  | 4       | –       | 100     | mV                |
| BW <sub>LF</sub>                | Small-Signal -3dB Low Frequency Cutoff.               | Excluding AC coupling capacitors   | –       | 4       | –       | kHz               |
| DJ                              | Deterministic Jitter                                  | K28.5 pattern at 500 Mbps  | –       | –       | 50      | ps                |
| RJ                              | Random Jitter   | 10 mV <sub>PP</sub> input  | –       | 3       | –       | ps <sub>RMS</sub> |
| t <sub>r</sub> / t <sub>f</sub> | Data Output Rise and Fall Times                       | 20% to 80%; outputs terminated into 50Ω; 10mV <sub>PP</sub> input  | –       | –       | 250     | ps                |
| T <sub>LOS_ON</sub>             | Time from LOS state until LOS output is asserted      | LOS assert time after 1 V <sub>PP</sub> input signal is turned off; signal detect level set to 10 mV                                   | 2.3     | –       | 80      | μs                |
| T <sub>LOS_OFF</sub>            | Time from non-LOS state until LOS is deasserted       | LOS deassert time after input crosses signal detect level; signal detect set to 10 mV with applied input signal of 20 mV <sub>PP</sub> | 2.3     | –       | 80      | μs                |

Preliminary Information

# 1.5 Safety Logic Timing

$V_{CC} = 3.05$  to  $3.55V$  or  $4.7$  to  $5.5V$ ,  $T_A = -40^{\circ}C$  to  $+95^{\circ}C$ , unless otherwise noted.  
 Typical values are  $V_{CC} = 3.3V$ ,  $I_{PB_{OUT}} = 4mA$ ,  $I_{MOD} = 50mA$ .

**Table 1-7. Safety Logic Timing**

| Symbol              | Parameter   | Conditions   | Minimum | Typical | Maximum | Units |
|---------------------|---|--|---------|---------|---------|-------|
| t <sub>off</sub>    | DIS assert time   | Rising edge of DIS to fall of output signal below 10% of nominal <sup>(1)</sup>                              | –       | 1       | 10      | μs    |
| t <sub>on</sub>     | DIS negate time   | Falling edge of DIS to rise of output signal above 90% of nominal <sup>(1)</sup>                             | –       | 0.4     | 1       | ms    |
| t <sub>init</sub>   | Time to initialize  | Includes reset of FAIL; from power on after Supply_OK or from negation of DIS during reset of FAIL condition | –       | 4       | 300     | ms    |
| t <sub>wc</sub>     | Window comparator hold-off time                             | Time during which the status of the fault detect comparators is ignored.                                     | 2       | 3       | –       | ms    |
| t <sub>fault</sub>  | LED fault time -- from fault condition to assertion of FAIL | From occurrence of fault condition or when Supply_OK is beyond specified range                               | –       | 16      | 100     | μs    |
| t <sub>reset</sub>  | DIS time to start reset                                     | DIS pulse width required to initialize safety circuitry or reset a latched fault                             | –       | –       | 10      | μs    |
| t <sub>VCC-OK</sub> | Supply okay delay time                                      | Delay between supply_OK condition and when outputs are enabled   | –       | 900     | –       | μs    |

**NOTE:**

1. With C<sub>PB</sub> = 47 nF.

**Figure 1-1. Safety Logic Simplified Block Diagram**

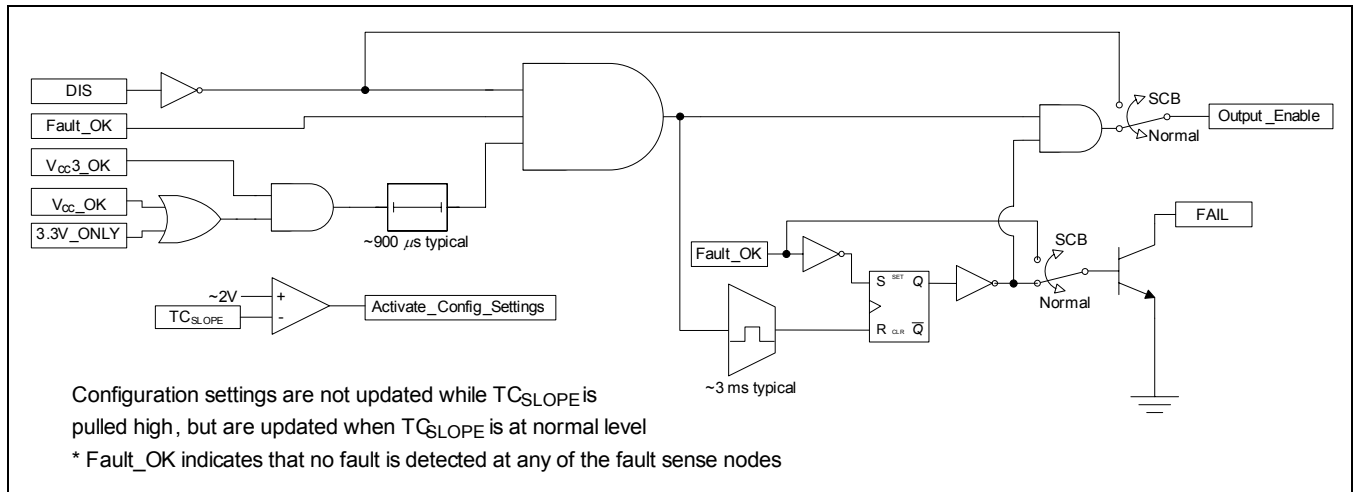

Preliminary Information

**Table 1-8. Circuit Response to Single-Point Fault Conditions on Driver Pins**

| Pin Name   | Circuit Response to Over-voltage Condition or Short to $V_{CC}$  | Circuit Response to Under-Voltage Condition or Short to Ground   |
|--|--|--|
| Config1-4  | Does not affect output power (some conditions can selectively enable/disable driver output).                                       | Does not affect output power (some conditions can selectively enable/disable driver output).   |
| $V_{CC}$   | Outputs are disabled if $V_{CC}$ exceeds the $V_{CC\_okay}$ (high level) threshold. If so, FAIL will be asserted. <sup>(1)</sup>   | Outputs are disabled if $V_{CC}$ voltage is below the $V_{CC\_okay}$ (low level) threshold. If so, FAIL will be asserted. <sup>(1)</sup>   |
| $V_{CC3T}$   | Outputs are disabled if $V_{CC3}$ exceeds the $V_{CC3\_okay}$ (high level) threshold. If so, FAIL will be asserted. <sup>(1)</sup> | Outputs are disabled if $V_{CC3}$ voltage is below the $V_{CC3\_okay}$ (low level) threshold. If so, FAIL will be asserted. <sup>(1)</sup> |
| DINp, DINm   | LED would remain in an optical one or zero condition.  | LED would remain in an optical one or zero condition.  |
| $C_{PB}$   | Pre-bias current is turned off. Does not affect LED operation.   | A fault state occurs. <sup>(2)</sup>   |
| FAIL   | Does not affect LED operation.   | Does not affect LED operation.   |
| DIS  | Bias and modulation outputs are disabled and $SV_{CC}$ is opened.  | Does not affect LED operation (normal condition for circuit operation).  |
| MOD <sub>SET</sub>   | No modulation current.   | A fault state occurs. <sup>(2)</sup>   |
| PB <sub>SET</sub>  | Pre-bias current is turned off. Does not affect LED power.   | A fault state occurs. <sup>(2)</sup>   |
| TC <sub>START</sub>  | Modulation current may increase depending on operating temperature and TC <sub>SLOPE</sub> setting.                                | Modulation current may decrease depending on operating temperature and TC <sub>SLOPE</sub> setting.  |
| TC <sub>SLOPE</sub>  | Modulation current may decrease depending on operating temperature and TC <sub>START</sub> setting.                                | Modulation current may increase depending on operating temperature and TC <sub>START</sub> setting.  |
| PB <sub>OUT</sub>  | The LED is turned off if connected to the LED cathode.   | A fault state occurs. <sup>(2)</sup>   |
| OUTP   | LED modulation is prevented and a fault state occurs. <sup>(2)</sup>   | A fault state occurs. <sup>(2)</sup>   |
| OUTN   | Does not affect LED operation.   | Does not affect LED operation.   |
| GND0   | LED modulation is prevented and a fault state may occur. <sup>(2)</sup>  | Does not affect LED operation.   |
| $SV_{CC}$  | Does not affect LED operation.   | The LED is turned off and a fault state occurs. <sup>(2)</sup>   |
| <b>NOTES:</b>  |  |  |
| <ol style="list-style-type: none"> <li>In this case a fault state will assert the FAIL output, but it is not latched. While the fault condition remains, the bias and modulation outputs are disabled and the switch at <math>SV_{CC}</math> is open. No fault occurs if in Safety Circuit Bypass (SCB).</li> <li>In this case a fault state will assert and latch the FAIL output, disable bias and modulation outputs and open the switch at <math>SV_{CC}</math>. No fault occurs if in Safety Circuit Bypass (SCB).</li> </ol> |  |  |

Preliminary Information

Figure 1-2. M02097 Safety Logic Timing Characteristics

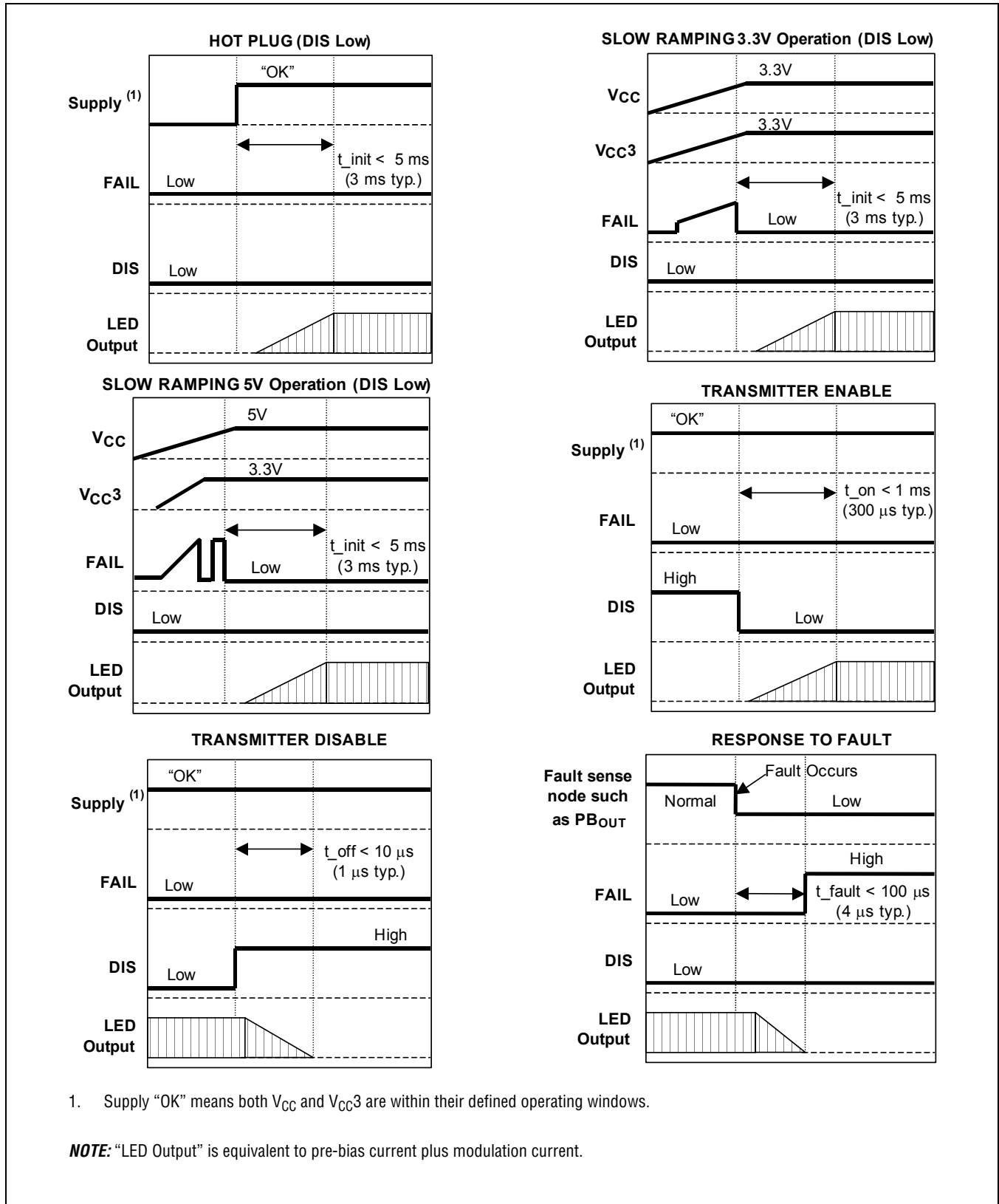

Preliminary Information

Figure 1-3. M02097 Safety Logic Timing Characteristics (Continued)

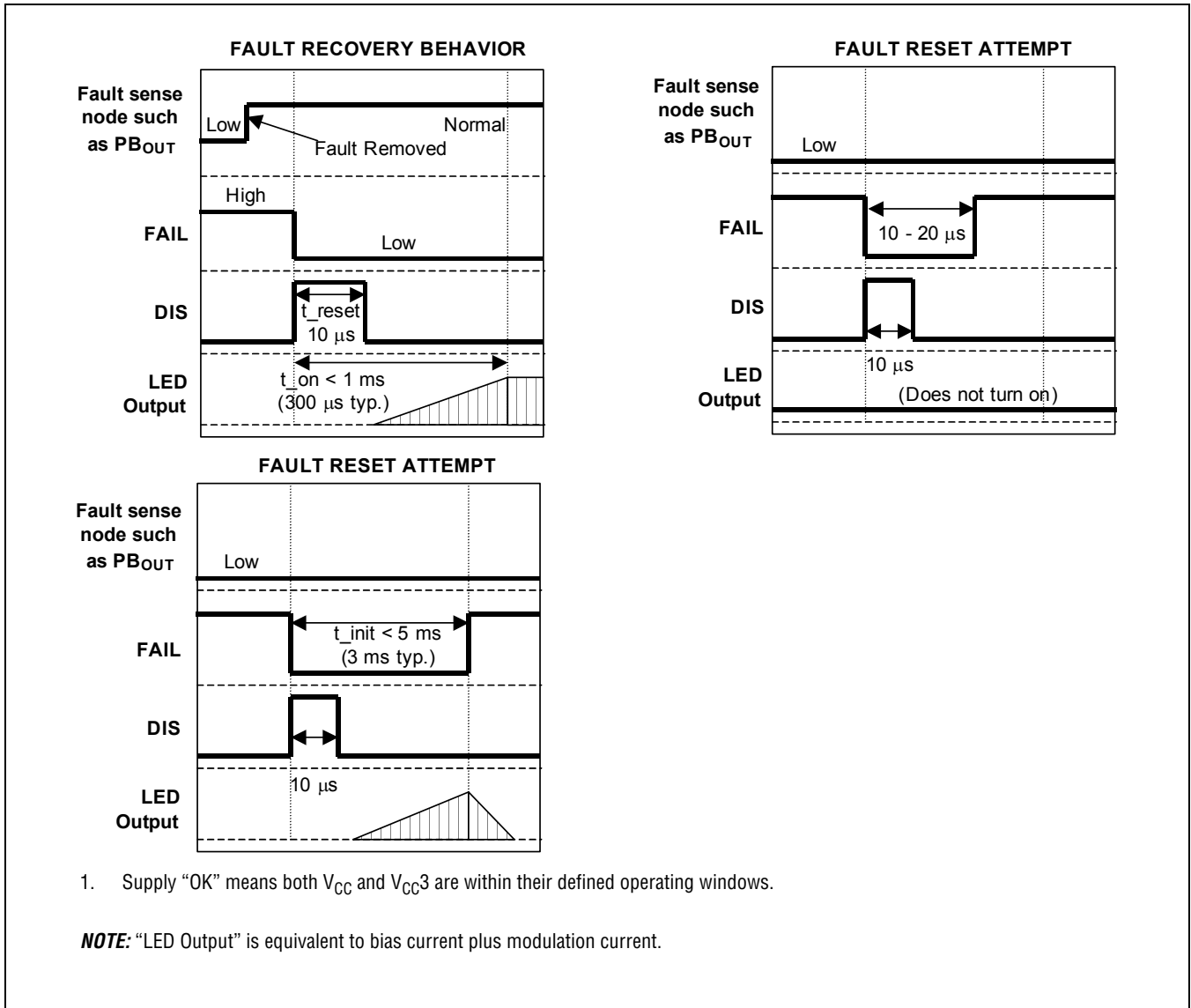

Preliminary Information

## 1.6 M02097 Configuration Logic

Table 1-9. M02097 Configuration Logic

| Config1 | Config2 | Config3 | Config4 | DIS/EN | LOS=JAM/<br>NO_JAM | LOS/ST | SCB | RxPOL | TxPOL | Special Config. |
|---------|---------|---------|---------|--------|--------------------|--------|-----|-------|-------|-----------------|
| 0       | 0       | 0       | 0       | 0      | 0                  | 0      | 0   | 0     | 0     | none            |
| 0       | 0       | 0       | M       | 0      | 0                  | 0      | 0   | 0     | 1     | none            |
| 0       | 0       | M       | 0       | 0      | 0                  | 0      | 0   | 1     | 0     | none            |
| 0       | 0       | M       | M       | 0      | 0                  | 0      | 0   | 1     | 1     | none            |
| 0       | 0       | 1       | 1       | 0      | 0                  | 0      | 1   | 0     | 0     | none            |
| 0       | 0       | 0       | 1       | 0      | 0                  | 0      | 1   | 0     | 1     | none            |
| 0       | 0       | 1       | 0       | 0      | 0                  | 0      | 1   | 1     | 0     | none            |
| 0       | 0       | M       | 1       | 0      | 0                  | 0      | 1   | 1     | 1     | none            |
| 0       | 0       | 1       | M       | 0      | 0                  | 0      | 0   | 0     | 0     | SC1             |
| 0       | M       | 0       | 0       | 0      | 0                  | 1      | 0   | 0     | 0     | none            |
| 0       | M       | 0       | M       | 0      | 0                  | 1      | 0   | 0     | 1     | none            |
| 0       | M       | M       | 0       | 0      | 0                  | 1      | 0   | 1     | 0     | none            |
| 0       | M       | M       | M       | 0      | 0                  | 1      | 0   | 1     | 1     | none            |
| 0       | M       | 1       | 1       | 0      | 0                  | 1      | 1   | 0     | 0     | none            |
| 0       | M       | 0       | 1       | 0      | 0                  | 1      | 1   | 0     | 1     | none            |
| 0       | M       | 1       | 0       | 0      | 0                  | 1      | 1   | 1     | 0     | none            |
| 0       | M       | M       | 1       | 0      | 0                  | 1      | 1   | 1     | 1     | none            |
| 0       | M       | 1       | M       | 0      | 0                  | 1      | 0   | 0     | 0     | SC2             |
| M       | 0       | 0       | 0       | 0      | 1                  | 0      | 0   | 0     | 0     | none            |
| M       | 0       | 0       | M       | 0      | 1                  | 0      | 0   | 0     | 1     | none            |
| M       | 0       | M       | 0       | 0      | 1                  | 0      | 0   | 1     | 0     | none            |
| M       | 0       | M       | M       | 0      | 1                  | 0      | 0   | 1     | 1     | none            |
| M       | 0       | 1       | 1       | 0      | 1                  | 0      | 1   | 0     | 0     | none            |
| M       | 0       | 0       | 1       | 0      | 1                  | 0      | 1   | 0     | 1     | none            |
| M       | 0       | 1       | 0       | 0      | 1                  | 0      | 1   | 1     | 0     | none            |
| M       | 0       | M       | 1       | 0      | 1                  | 0      | 1   | 1     | 1     | none            |
| M       | 0       | 1       | M       | 0      | 1                  | 0      | 0   | 0     | 0     | SC3             |
| M       | M       | 0       | 0       | 0      | 1                  | 1      | 0   | 0     | 0     | none            |
| M       | M       | 0       | M       | 0      | 1                  | 1      | 0   | 0     | 1     | none            |
| M       | M       | M       | 0       | 0      | 1                  | 1      | 0   | 1     | 0     | none            |
| M       | M       | M       | M       | 0      | 1                  | 1      | 0   | 1     | 1     | none            |
| M       | M       | 1       | 1       | 0      | 1                  | 1      | 1   | 0     | 0     | none            |
| M       | M       | 0       | 1       | 0      | 1                  | 1      | 1   | 0     | 1     | none            |

Preliminary Information

**Table 1-9. M02097 Configuration Logic**

| Config1 | Config2 | Config3 | Config4 | DIS/EN | LOS=JAM/<br>NO_JAM | LOS/ST | SCB | RxPOL | TxPOL | Special Config. |
|---------|---------|---------|---------|--------|--------------------|--------|-----|-------|-------|-----------------|
| M       | M       | 1       | 0       | 0      | 1                  | 1      | 1   | 1     | 0     | none            |
| M       | M       | M       | 1       | 0      | 1                  | 1      | 1   | 1     | 1     | none            |
| M       | M       | 1       | M       | 0      | 1                  | 1      | 0   | 0     | 0     | SC4             |
| 1       | 1       | 0       | 0       | 1      | 0                  | 0      | 0   | 0     | 0     | none            |
| 1       | 1       | 0       | M       | 1      | 0                  | 0      | 0   | 0     | 1     | none            |
| 1       | 1       | M       | 0       | 1      | 0                  | 0      | 0   | 1     | 0     | none            |
| 1       | 1       | M       | M       | 1      | 0                  | 0      | 0   | 1     | 1     | none            |
| 1       | 1       | 1       | 1       | 1      | 0                  | 0      | 1   | 0     | 0     | none            |
| 1       | 1       | 0       | 1       | 1      | 0                  | 0      | 1   | 0     | 1     | none            |
| 1       | 1       | 1       | 0       | 1      | 0                  | 0      | 1   | 1     | 0     | none            |
| 1       | 1       | M       | 1       | 1      | 0                  | 0      | 1   | 1     | 1     | none            |
| 1       | 1       | 1       | M       | 1      | 0                  | 0      | 0   | 0     | 0     | SC5             |
| 0       | 1       | 0       | 0       | 1      | 0                  | 1      | 0   | 0     | 0     | none            |
| 0       | 1       | 0       | M       | 1      | 0                  | 1      | 0   | 0     | 1     | none            |
| 0       | 1       | M       | 0       | 1      | 0                  | 1      | 0   | 1     | 0     | none            |
| 0       | 1       | M       | M       | 1      | 0                  | 1      | 0   | 1     | 1     | none            |
| 0       | 1       | 1       | 1       | 1      | 0                  | 1      | 1   | 0     | 0     | none            |
| 0       | 1       | 0       | 1       | 1      | 0                  | 1      | 1   | 0     | 1     | none            |
| 0       | 1       | 1       | 0       | 1      | 0                  | 1      | 1   | 1     | 0     | none            |
| 0       | 1       | M       | 1       | 1      | 0                  | 1      | 1   | 1     | 1     | none            |
| 0       | 1       | 1       | M       | 1      | 0                  | 1      | 0   | 0     | 0     | SC5             |
| 1       | 0       | 0       | 0       | 1      | 1                  | 0      | 0   | 0     | 0     | none            |
| 1       | 0       | 0       | M       | 1      | 1                  | 0      | 0   | 0     | 1     | none            |
| 1       | 0       | M       | 0       | 1      | 1                  | 0      | 0   | 1     | 0     | none            |
| 1       | 0       | M       | M       | 1      | 1                  | 0      | 0   | 1     | 1     | none            |
| 1       | 0       | 1       | 1       | 1      | 1                  | 0      | 1   | 0     | 0     | none            |
| 1       | 0       | 0       | 1       | 1      | 1                  | 0      | 1   | 0     | 1     | none            |
| 1       | 0       | 1       | 0       | 1      | 1                  | 0      | 1   | 1     | 0     | none            |
| 1       | 0       | M       | 1       | 1      | 1                  | 0      | 1   | 1     | 1     | none            |
| 1       | 0       | 1       | M       | 1      | 1                  | 0      | 0   | 0     | 0     | SC6             |
| M       | 1       | 0       | 0       | 1      | 1                  | 1      | 0   | 0     | 0     | none            |
| 1       | M       | 0       | 0       | 1      | 1                  | 1      | 0   | 0     | 0     | SC7             |
| M       | 1       | 0       | M       | 1      | 1                  | 1      | 0   | 0     | 1     | none            |
| 1       | M       | 0       | M       | 1      | 1                  | 1      | 0   | 0     | 1     | SC8             |
| M       | 1       | M       | 0       | 1      | 1                  | 1      | 0   | 1     | 0     | none            |

Preliminary Information

**Table 1-9. M02097 Configuration Logic**

| Config1 | Config2 | Config3 | Config4 | DIS/EN | LOS=JAM/<br>NO_JAM | LOS/ST | SCB | RxPOL | TxPOL | Special Config. |
|---------|---------|---------|---------|--------|--------------------|--------|-----|-------|-------|-----------------|
| 1       | M       | M       | 0       | 1      | 1                  | 1      | 0   | 1     | 0     | SC9             |
| M       | 1       | M       | M       | 1      | 1                  | 1      | 0   | 1     | 1     | none            |
| 1       | M       | M       | M       | 1      | 1                  | 1      | 0   | 1     | 1     | SC10            |
| M       | 1       | 1       | 1       | 1      | 1                  | 1      | 1   | 0     | 0     | none            |
| 1       | M       | 1       | 1       | 1      | 1                  | 1      | 1   | 0     | 0     | SC5             |
| M       | 1       | 0       | 1       | 1      | 1                  | 1      | 1   | 0     | 1     | none            |
| 1       | M       | 0       | 1       | 1      | 1                  | 1      | 1   | 0     | 1     | SC3             |
| M       | 1       | 1       | 0       | 1      | 1                  | 1      | 1   | 1     | 0     | none            |
| 1       | M       | 1       | 0       | 1      | 1                  | 1      | 1   | 1     | 0     | SC11            |
| M       | 1       | M       | 1       | 1      | 1                  | 1      | 1   | 1     | 1     | none            |
| M       | 1       | 1       | M       | 1      | 1                  | 1      | 0   | 0     | 0     | SC12            |
| 1       | M       | M       | 1       | 1      | 1                  | 1      | 1   | 1     | 1     | SC13            |
| 1       | M       | 1       | M       | 1      | 1                  | 1      | 0   | 0     | 0     | SC14            |

KEY:  
 0, 1, M:0 = Logic low; 1 = Logic high; M = pin floating (pin goes to intermediate “mid-range” self-biased voltage)  
 DIS/EN:0 = DIS pin acts as Tx\_Disable; 1 = DIS pin becomes Tx\_Enable  
 LOS=JAM / NO\_JAM:0 = Jam outputs upon LOS; 1 = Do not jam outputs upon LOS  
 LOS/ST:0 = LOS-ST pin is ST (goes high with signal detect); 1 = LOS-ST pin is high with LOS  
 SCB:0=latched fault; 1=safety circuit bypass mode  
 TxPOL and RxPOL:0 = default polarity; 1 = inverted polarity  
 Special Config.:Refer to Special Configurations table for definition of special configuration modes

Preliminary Information

**Table 1-10. M02097 Special Configurations**

| Special Config. # | Special Config. Name | Definition  |
|-------------------|----------------------|---|
| SC1 - SC11        | Test Modes           | Internal Use Only; do not use   |
| SC12              | DCRDIS               | Disables the DC restore in the limiting amplifier. Can pass DC signal through limiting amp, but offset at limiting amplifier input passes through to outputs. |
| SC13-14           | Test Modes           | Internal Use Only; do not use   |



## 2.0 Pin Definitions

Table 2-1. M02097 Pad / Pin Descriptions (1 of 2)

| QFN Pin Number | Pin Name            | Function  |
|----------------|---------------------|---|
| 1              | RxOUTm              | Limiting amplifier inverting data output (PECL). Output is referenced to the Rx supply input ( $V_{CCR}$ ).   |
| 2              | RxOUTp              | Limiting amplifier non-inverting data output (PECL). Output is referenced to the Rx supply input ( $V_{CCR}$ ).   |
| 3              | $V_{CCR}$           | Power supply for limiting amplifier circuitry (3.3V or 5V).   |
| 4              | $V_{CCT}$           | Power supply for LED driver circuitry (3.3V or 5V).   |
| 5              | TC <sub>SLOPE</sub> | Modulation temperature compensation slope. A resistor to ground sets the level of temperature compensation for the modulation current. Forcing this pin high (to 3.3V) causes the configuration logic to ignore configuration logic settings until this pin is released to its normal level (~1.25V). Temperature compensation is disabled if this pin is floating. |
| 6              | TC <sub>START</sub> | A resistor to ground at this pin sets the temperature at which the modulation temperature compensation slope becomes active. Letting this pin float results in a start temperature of ~40°C. Grounding this pin disables temperature compensation.  |
| 7              | DINp                | Transmitter positive Data Input. Internally terminated with 4 k $\Omega$ to self-bias voltage of approximately $V_{CC3T} - 0.65V$ . Can be AC coupled.  |
| 8              | DINm                | Transmitter negative Data Input. Internally terminated with 4 k $\Omega$ to self-bias voltage of approximately $V_{CC3T} - 0.65V$ . Can be AC coupled.  |
| 9              | FAIL                | Safety circuit fault indicator. Goes high when a safety logic fault is detected. The FAIL output is low when DIS is high. Open collector; 4.7 k $\Omega$ to 10 k $\Omega$ external pull-up required. 5V compatible when using a 5V supply.  |
| 10             | DIS                 | Disable control (TTL compatible). When high or left floating, the bias and modulation outputs are disabled. Set low for normal operation. 7 k $\Omega$ internal pull-up to $V_{CCT}$ .  |
| 11             | MOD <sub>SET</sub>  | Modulation Current Adjust. Connect a resistor between this pin and ground to set LED modulation current.  |
| 12             | NC                  | No connect, leave floating. Do not connect to ground or $V_{CC}$ .  |
| 13             | NC                  | No connect, leave floating. Do not connect to ground or $V_{CC}$ .  |
| 14             | PB <sub>SET</sub>   | A resistor connected from this pin to ground sets the LED pre-bias current. Leave floating if pre-bias is not used.   |
| 15             | NC                  | Not connected in package.   |
| 16             | PB <sub>OUT</sub>   | LED pre-bias current output. Connect to LED cathode with a 100 $\Omega$ resistor between the LED anode and cathode.   |
| 17             | GND0                | Ground for modulation output stage. Connect directly to ground or can connect to ground through an inductor.  |
| 18             | OUTP                | Transmitter positive modulation output. Draws current when DINp is high. Referenced to the $SV_{CC}$ (transmitter regulator output) voltage.  |
| 19             | OUTN                | Transmitter negative modulation output. Draws current when DINp is low. Referenced to the $SV_{CC}$ (transmitter regulator output) voltage.   |
| 20             | $SV_{CC}$           | Internal power supply switch for LED. Provides redundant shutdown during a disable or fault condition.  |

Preliminary Information

Table 2-1. M02097 Pad / Pin Descriptions (2 of 2)

| QFN Pin Number | Pin Name          | Function   |
|----------------|-------------------|--|
| 21             | V <sub>CC3T</sub> | Internally regulated voltage for LED driver circuitry in 5V applications. Connect directly to supply to allow wider power supply tolerance in 3.3V-only applications (internal regulator not in use). Do not connect to power supply if V <sub>CC</sub> = 5V.                |
| 22             | C <sub>PB</sub>   | A capacitor at this pin sets the compensation for the pre-bias control. Connect a capacitor between this pin and V <sub>CC3</sub> if pre-bias control is used. Can leave floating if not using pre-bias.   |
| 23             | ST <sub>SET</sub> | Loss of signal threshold setting input. Connect a resistor between this pin and V <sub>CC3</sub> to set loss of signal threshold.  |
| 24             | V <sub>CC3R</sub> | Internally regulated voltage for limiting amplifier circuitry in 5V applications. Connect directly to supply to allow wider power supply tolerance in 3.3V-only applications (internal regulator not in use). Do not connect to power supply if V <sub>CC</sub> = 5V.        |
| 25             | RxINp             | Non-inverting limiting amplifier data input. Internally terminated with 2 kΩ to self-bias voltage of approximately V <sub>CC3R</sub> - 0.5V.   |
| 26             | RxINm             | Inverting limiting amplifier data input. Internally terminated with 2 kΩ to self-bias voltage of approximately V <sub>CC3R</sub> - 0.5V.   |
| 27             | Config1           | Configuration logic input. These pins select LED driver and limiting amplifier configurations and test modes. Refer to Configuration Logic table (Table 1-9) for more information. Three level logic where nominal level is mid-range (V <sub>CC3T</sub> / 2) when floating. |
| 28             | Config2           |  |
| 29             | Config3           |  |
| 30             | Config4           |  |
| 31             | LOS-ST            | Limiting amplifier LOS or ST (signal detect) output (M02097-11 PECL, M02097-21 CMOS). Configuration logic selects whether output is to be LOS or ST. 5V compatible when using a 5V supply.   |
| 32             | I <sub>REF</sub>  | Internal reference current. Must be connected to ground through a 12.4 kΩ 1% resistor.   |

Figure 2-1. M02097 Package Pin-out (5x5mm MLF)

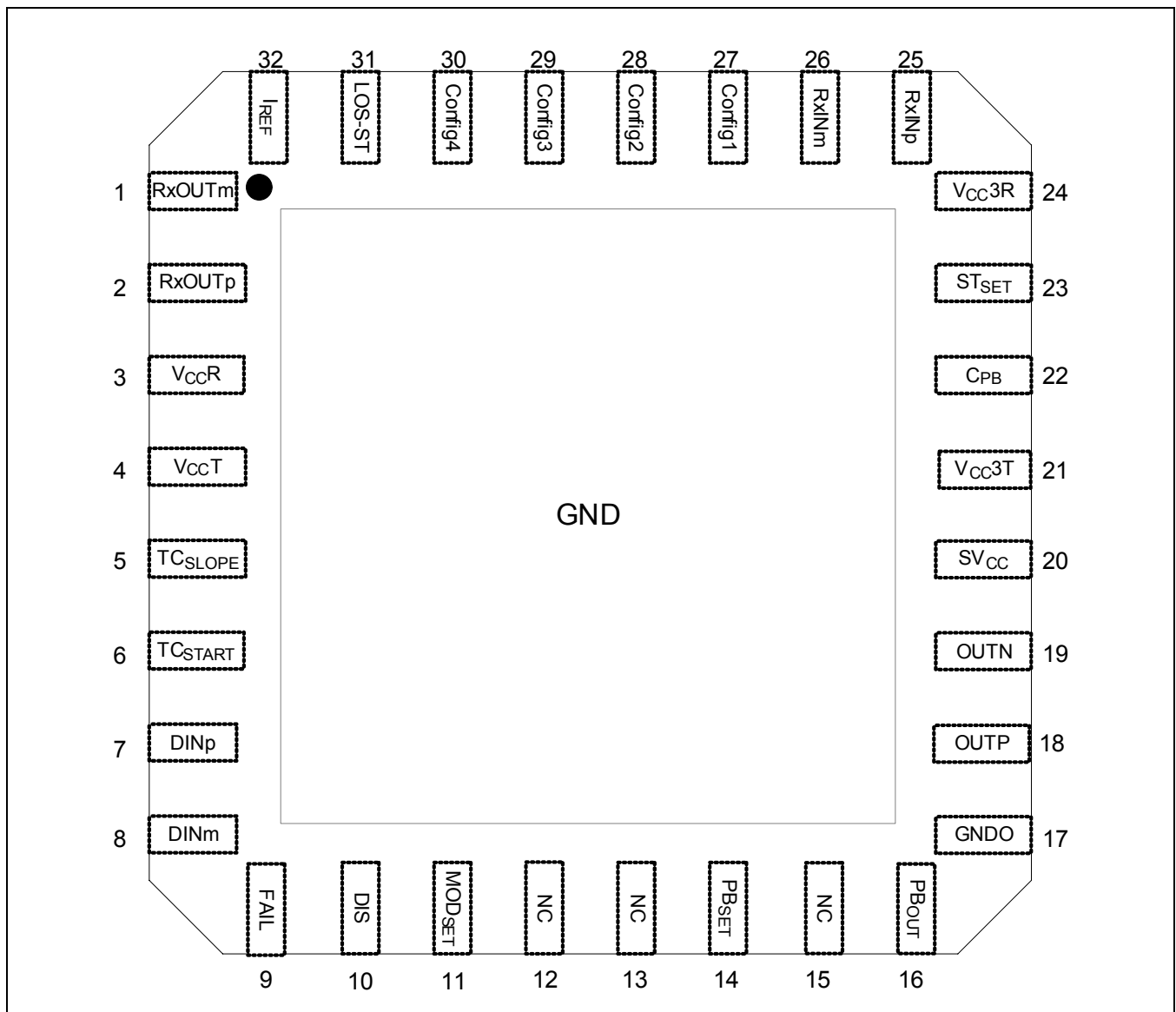

Preliminary Information



# 3.0 Functional Description

## 3.1 Overview

The M02097 device is a highly integrated combined LED driver and limiting amplifier intended for applications to 500 Mbps. The part can be operated from a single 3.3V or 5V supply.

Many features are user-adjustable, including the pre-bias current, modulation current, temperature compensation control of modulation current, loss of signal threshold, using jam or not on the Rx path and the Rx and Tx polarity.

Safety circuitry is also included to provide a latched shut-down of LED bias and modulation current if a fault condition occurs. An internal  $V_{CC}$  switch provides redundant shutdown of the LED current under a fault condition.

Figure 3-1. M02097 Block Diagram

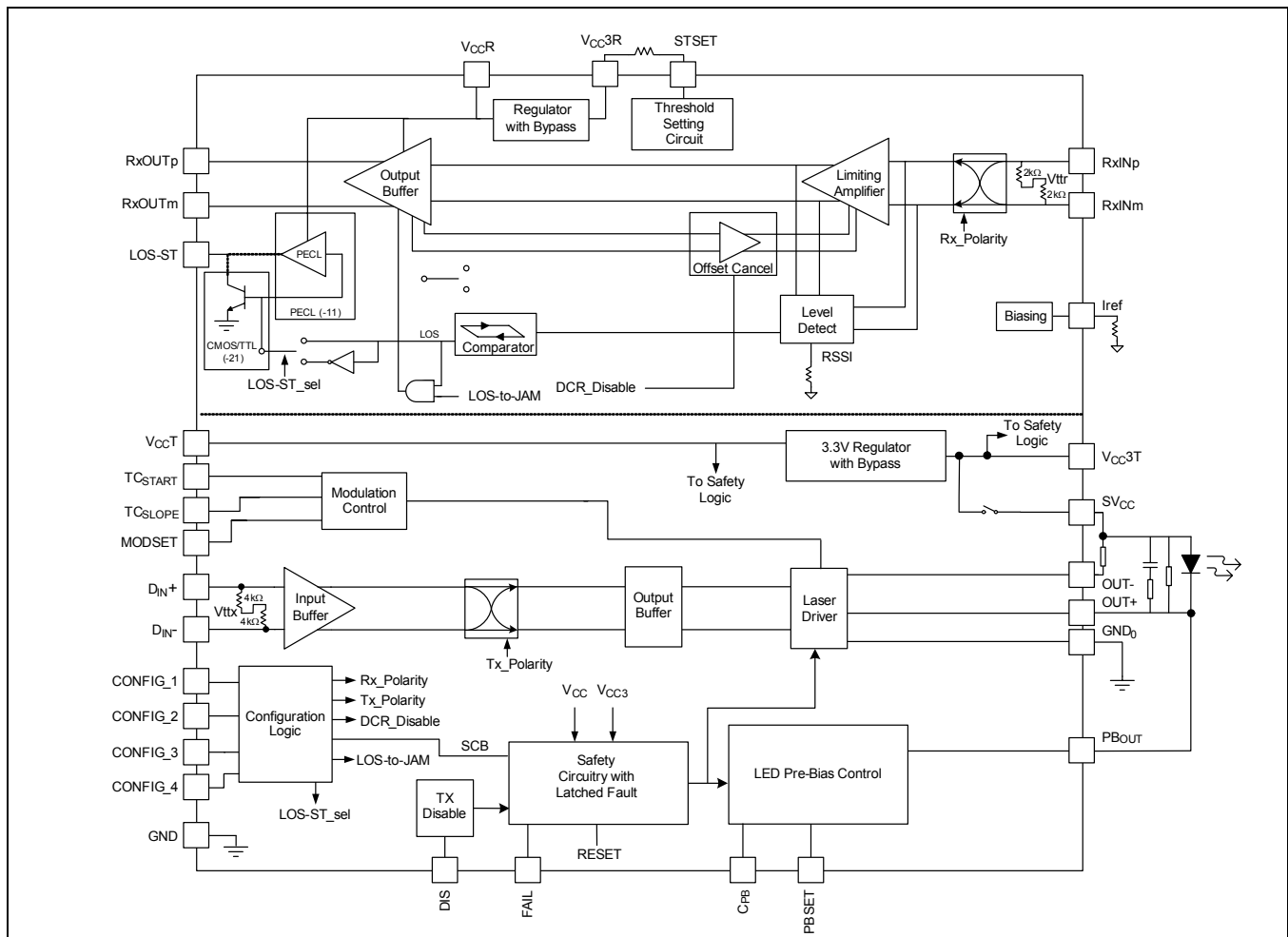

Preliminary Information

## 3.2 Internal Regulator

When operating from a 5V supply ( $V_{CC}$  connected to +5V), an internal regulator provides a voltage of approximately 3.3V to the majority of the on-chip circuitry. The on-chip regulator is internally compensated, requiring no external components. When a 3.3V supply is used ( $V_{CC}$  connected to 3.3V, or both  $V_{CC}$  and  $V_{CC3}$  connected to 3.3V), internal logic configures the device for 3.3V operation and the regulator is switched to a low-resistance mode. The device decides whether or not the internal regulator is enabled using internal sensing logic, the sensing logic also determines whether the device safety circuitry needs to monitor for proper +5V supply voltage.

## 3.3 Driver Inputs

The inputs to the data buffer are self-biased through resistors to an internal reference of approximately  $V_{CC} - 1.3V$ . Both CML and PECL input signals can be AC coupled to the M02097. AC coupling is recommended when using the internal regulator ( $V_{CC} = 5V$ ), though external level-shifting may be used if DC coupling is desired with 5V supply.

## 3.4 Driver Output Stage

The output stage incorporates feedback to maintain performance over the range of LED modulation current. The output stage is nominally configured to drive an output load of  $\sim 5\Omega$  with shunt RC compensation for LEDs. OUTP should be connected directly to the LED cathode. This will result in the optimum pulse response while allowing the maximum modulation current to be achieved when the output is DC coupled to the load. The LED driver output stage is separately grounded from the rest of the circuitry (through GNDO) for optimum performance and control of output characteristics.

The output can also be AC coupled to the LED. LED modulation current is controlled by adjusting current at  $MOD_{SET}$ . The modulation current can be temperature compensated by setting slope through the  $TC_{SLOPE}$  pin and  $TC_{START}$  sets the temperature at which the temperature compensation begins to operate.

## 3.5 Safety Circuitry

Comparators at  $PB_{SET}$ ,  $MOD_{SET}$ ,  $PB_{OUT}$ ,  $OUTP$ , and  $C_{PB}$  will assert the FAIL output, indicating that a fault condition has occurred. This condition is latched and requires DIS to be toggled or power cycling before reset occurs.  $SV_{CC}$  is opened during a fault or disable condition.

By setting DIS high, the bias and modulation output currents are disabled. DIS will disable LED bias and modulation current if left floating. DIS must be forced to a low state to enable the outputs. When safety circuit bypass (SCB) mode is enabled, FAIL will indicate a fault condition, but the outputs will not be disabled under a fault condition. Only the DIS pin will shutdown the outputs when in SCB mode.



# 4.0 Package Specification

Figure 4-1. QFN32 Package Information

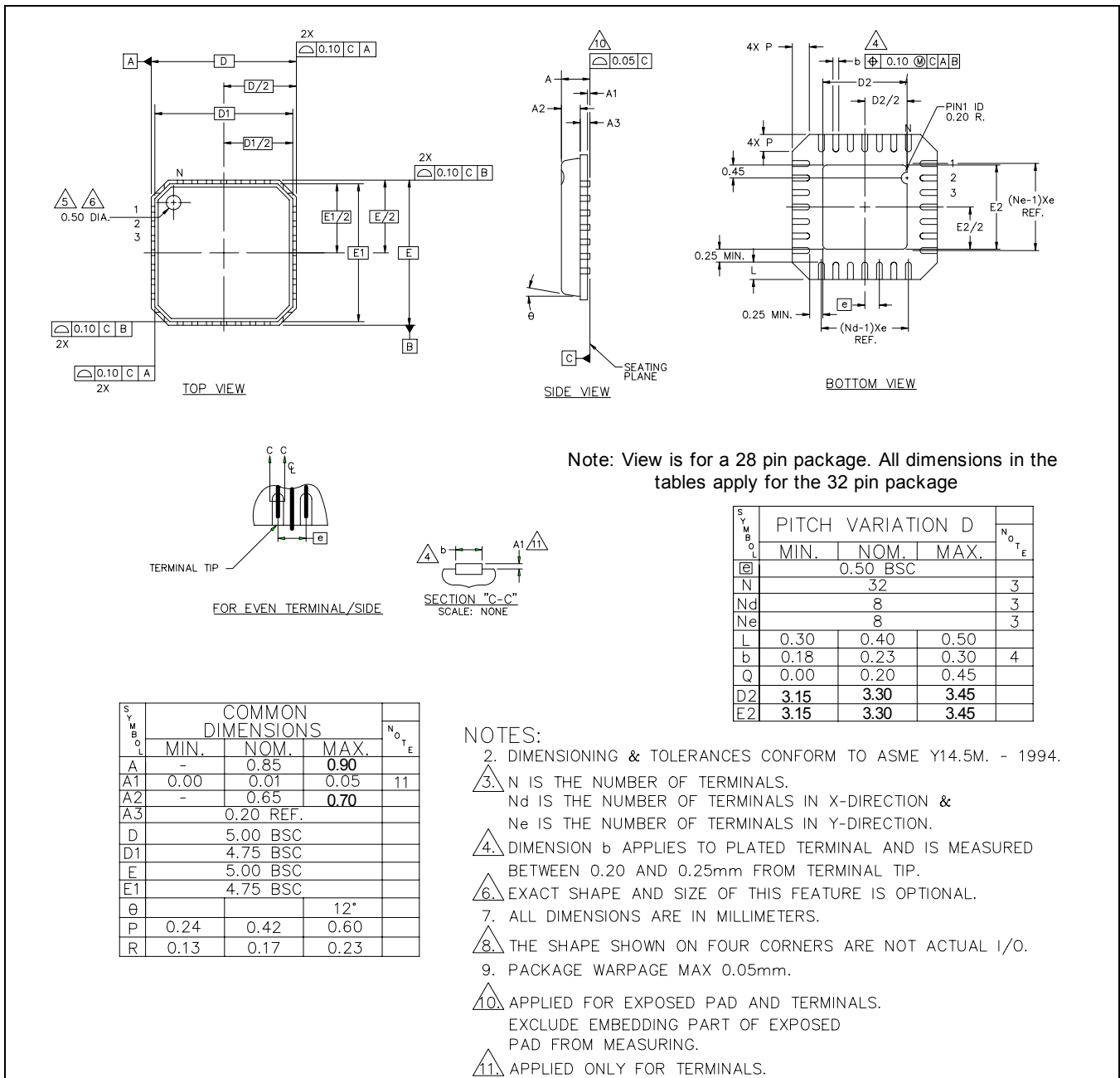

Preliminary Information

[www.mindspeed.com](http://www.mindspeed.com)

General Information:  
Telephone: (949) 579-3000  
Headquarters - Newport Beach  
4000 MacArthur Blvd., East Tower  
Newport Beach, CA 92660

© 2006 Mindspeed Technologies®, Inc. All rights reserved.

Information in this document is provided in connection with Mindspeed Technologies® ("Mindspeed®") products. These materials are provided by Mindspeed as a service to its customers and may be used for informational purposes only. Except as provided in Mindspeed's Terms and Conditions of Sale for such products or in any separate agreement related to this document, Mindspeed assumes no liability whatsoever. Mindspeed assumes no responsibility for errors or omissions in these materials. Mindspeed may make changes to specifications and product descriptions at any time, without notice. Mindspeed makes no commitment to update the information and shall have no responsibility whatsoever for conflicts or incompatibilities arising from future changes to its specifications and product descriptions. No license, express or implied, by estoppel or otherwise, to any intellectual property rights is granted by this document.

THESE MATERIALS ARE PROVIDED "AS IS" WITHOUT WARRANTY OF ANY KIND, EITHER EXPRESS OR IMPLIED, RELATING TO SALE AND/OR USE OF MINDSPEED PRODUCTS INCLUDING LIABILITY OR WARRANTIES RELATING TO FITNESS FOR A PARTICULAR PURPOSE, CONSEQUENTIAL OR INCIDENTAL DAMAGES, MERCHANTABILITY, OR INFRINGEMENT OF ANY PATENT, COPYRIGHT OR OTHER INTELLECTUAL PROPERTY RIGHT. MINDSPEED FURTHER DOES NOT WARRANT THE ACCURACY OR COMPLETENESS OF THE INFORMATION, TEXT, GRAPHICS OR OTHER ITEMS CONTAINED WITHIN THESE MATERIALS. MINDSPEED SHALL NOT BE LIABLE FOR ANY SPECIAL, INDIRECT, INCIDENTAL, OR CONSEQUENTIAL DAMAGES, INCLUDING WITHOUT LIMITATION, LOST REVENUES OR LOST PROFITS, WHICH MAY RESULT FROM THE USE OF THESE MATERIALS.

Mindspeed products are not intended for use in medical, lifesaving or life sustaining applications. Mindspeed customers using or selling Mindspeed products for use in such applications do so at their own risk and agree to fully indemnify Mindspeed for any damages resulting from such improper use or sale.