



## **SED1353 Graphics LCD Controller**

# **SED1353 TECHNICAL MANUAL**

**Issue Date: 98/01/27**

**Document No. X18A-Q-001-04**

Copyright © 1997, 1998 S-MOS Systems Inc. All rights reserved.

This document, and any text derived, extracted or transmitted from it, is the sole property of S-MOS Systems Inc. and may not be used, copied, transmitted or otherwise made available to any other person, unless specifically allowed under license agreement with S-MOS Systems Inc. If furnished under a license, this document may be used and copied only in accordance with the terms of such license, and with the inclusion of this copyright notice. No title or ownership of the technology herein is transferred.

The information in this document is subject to change without notice and should not be construed as a commitment by S-MOS Systems Inc. This document does not necessarily describe any current planned or future product by S-MOS Systems Inc., nor does it represent any commitment to implement any such product.

**THIS PAGE LEFT BLANK**

---

# CUSTOMER SUPPORT INFORMATION

## Comprehensive Support Tools

S-MOS Systems provides to the system designer and computer OEM manufacturer a complete set of resources and tools for the development of graphics systems.

## Evaluation / Demonstration Board

- Assembled and fully tested graphics evaluation board with installation guide and schematics
- To borrow an evaluation board, please contact your local S-MOS sales representative or contact S-MOS at (408) 922-0200 Ext. 3440

## VGA Chip Documentation

- Technical manual includes Data Sheet, Application Notes, and Programmer's Reference
- To remain on the mailing list for updates to this manual, please FAX the *Acknowledgment of Receipt* form to (408) 922-0238

## Software

- Video BIOS
- OEM Utilities
- User Utilities
- Evaluation Software
- To download these programs, contact Application Engineering Support

## Application Engineering Support

Engineering and Sales Support is provided by:

### Head Office

S-MOS Systems Inc.  
150 River Oaks Parkway  
San Jose, CA 95134  
Tel: (408) 922-0200  
Fax: (408) 922-0238  
<http://www.smos.com>

### North Central USA

1450 East American Lane  
Suite 1550  
Schaumburg, Illinois 60173  
Tel: (847) 517-7667  
Fax: (847) 517-7601  
Cell: (847) 558-6662  
Pager: (888) 789-3471

### Eastern USA

301 Edgewater Place  
Suite 120  
Wakefield, MA 01880  
Tel: (781) 246-3600  
Fax: (781) 246-5443

### Southeast USA

4300 Six Forks Road  
Suite 430  
Raleigh, NC 27609  
Tel: (919) 781-7667  
Fax: (919) 781-6778

**THIS PAGE LEFT BLANK**

---

## TABLE OF CONTENTS

### INTRODUCTION

SED1353 Graphics LCD Controller Data Sheet

### SPECIFICATION

SED1353 Hardware Functional Specification

### PROGRAMMER'S REFERENCE

SED1353 Programming Notes and Examples

### UTILITIES

1353SHOW.EXE Display Utility

1353VIRT.EXE Display Utility

1353BIOS.COM Display Utility

1353MODE.EXE Display Utility

1353PD.EXE Power Down Utility

1353READ.EXE Diagnostic Utility

### EVALUATION

SDU1353B0C Rev 1 Evaluation Board User Manual

### APPLICATION NOTES

Power Consumption

ISA Bus Interface Considerations

MC68340 Interface Considerations

LCD Panel Options/Memory Requirements

SED1353F0A/SED1352F0B Feature Comparison

**THIS PAGE LEFT BLANK**

## SED1353 GRAPHICS LCD CONTROLLER

### ■ DESCRIPTION

The SED1353 is a dot matrix graphic LCD controller supporting resolutions up to 1024x1024. It is capable of displaying a maximum of 256 simultaneous colors out of a possible 4096 or 16 gray shades. Design flexibility allows the SED1353 to interface to either an MC68000 family microprocessor or an 8/16-bit MPU/bus with minimum external logic. The Static RAM (SRAM) interface used for the display buffer is optimized for speed and performance, supporting up to 128K bytes.

Two power save modes, combined with operating voltages of 2.7 volts through 5.5 volts, allow for a wide range of applications while providing minimum power consumption.

### ■ FEATURES

- pin compatible with the SED1352
- 16-bit 16 MHz MC68xxx MPU interface
- 8/16-bit MPU interface controlled by a READY (or WAIT#) signal
- option to use built-in index register or direct-mapping to access one of sixteen internal registers
- 2-terminal crystal or external oscillator support
- 8/16-bit SRAM interface configurations
- split screen display support allowing two different images to be simultaneously displayed
- virtual display support (displays images larger than the panel size through the use of panning)
- display modes:
  - black-and-white display
  - 2/4 bits per pixel, 4/16-level gray-scale display
  - 2/4/8 bits per pixel, 4/16/256-level color display
- two software power-save modes
- low power consumption
- display memory interface:
  - 128K bytes using one 64Kx16 SRAMs
  - 128K bytes using two 64Kx8 SRAMs
  - 64K bytes using two 32Kx8 SRAMs
  - 40K bytes using one 8Kx8 and one 32Kx8 SRAM
  - 32K bytes using one 32Kx8 SRAM
  - 16K bytes using two 8Kx8 SRAMs
  - 8K bytes using one 8Kx8 SRAM
- LCD panel configurations:
  - single-panel, single-drive passive display
  - dual-panel, dual-drive passive display
- maximum number of vertical lines:
  - 1,024 lines (single-panel, single-drive display)
  - 2,048 lines (dual-panel, dual-drive display)
- QFP5-100-S2 package (F0A)
- QFP15-100-STD package (F1A)

### ■ SYSTEM BLOCK DIAGRAM

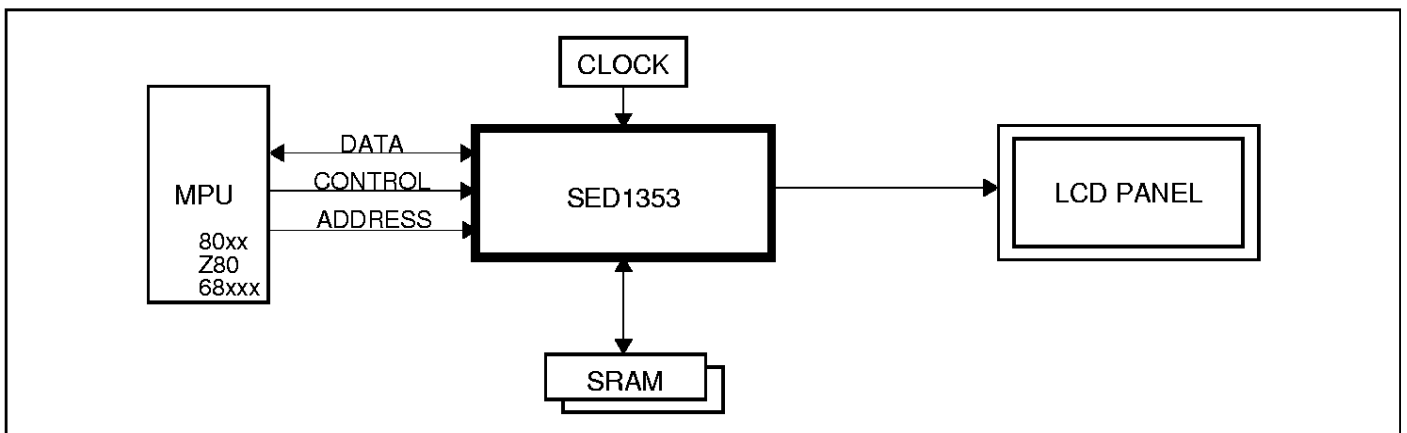

## SED1353

### ■ INTERFACE OPTIONS

#### Interface with 16-Bit MC68xxx MPU and 16K bytes SRAM (2 of 8K x 8)

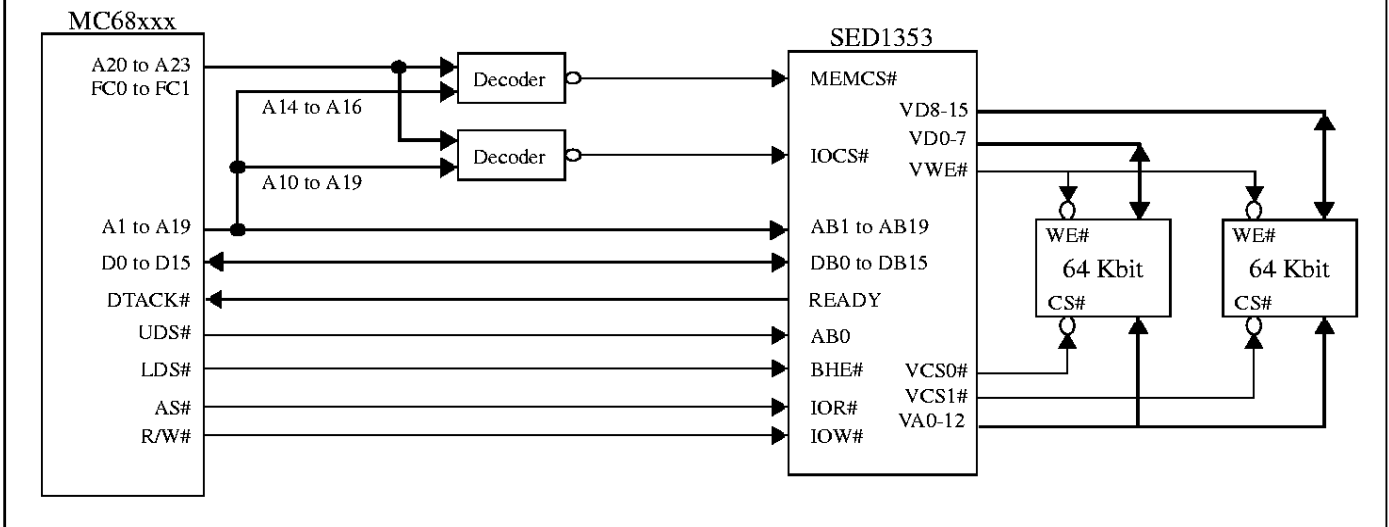

Note: Example implementation, actual may vary.

#### Interface with 8-Bit Z80 MPU and 16K bytes SRAM (2 of 8K x 8)

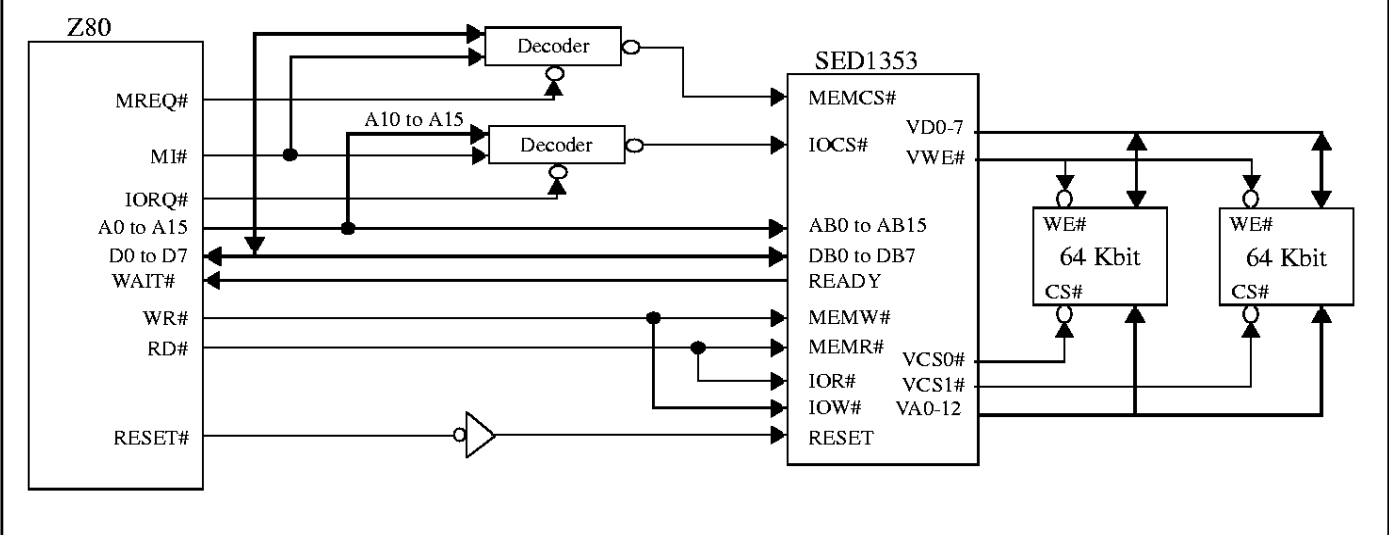

Note: Example implementation, actual may vary.



**Interface with 16-Bit 8086 MPU and 64K bytes SRAM (2 of 32K x 8)**

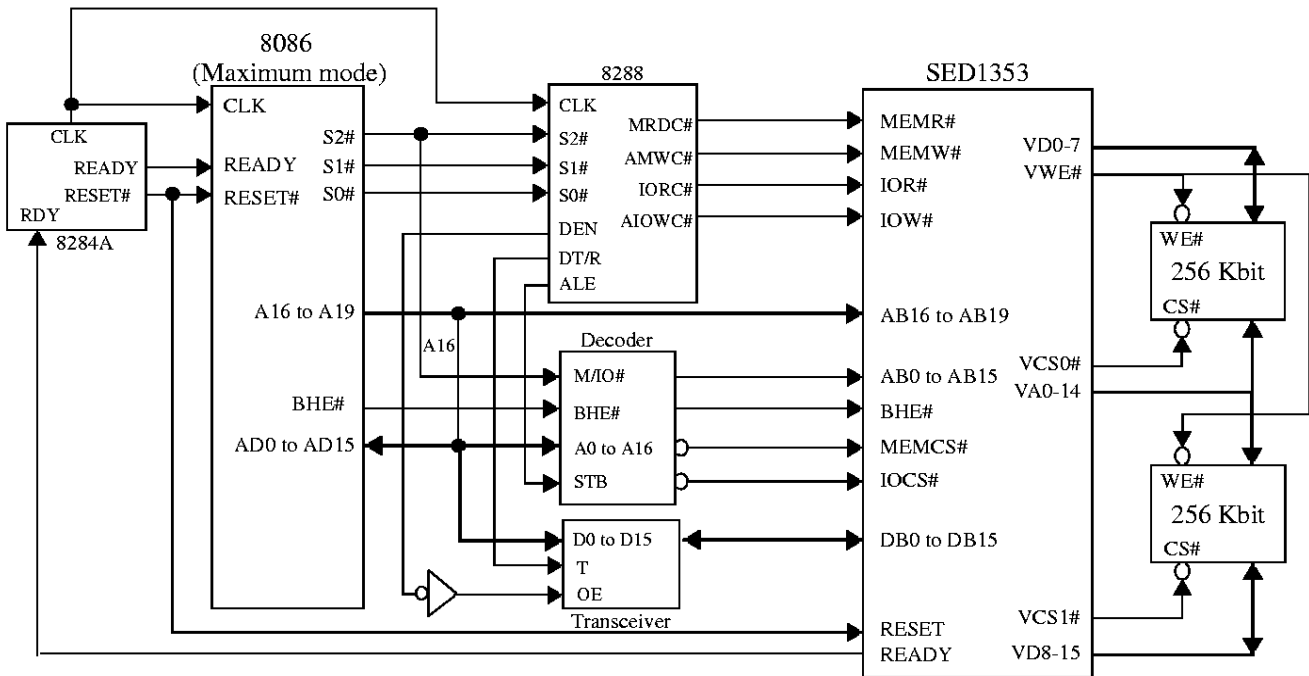

Note: Example implementation, actual may vary.

**Interface with 8-Bit ISA Bus and 40K bytes SRAM (1 of 8K x 8 and 1 of 32K x 8)**

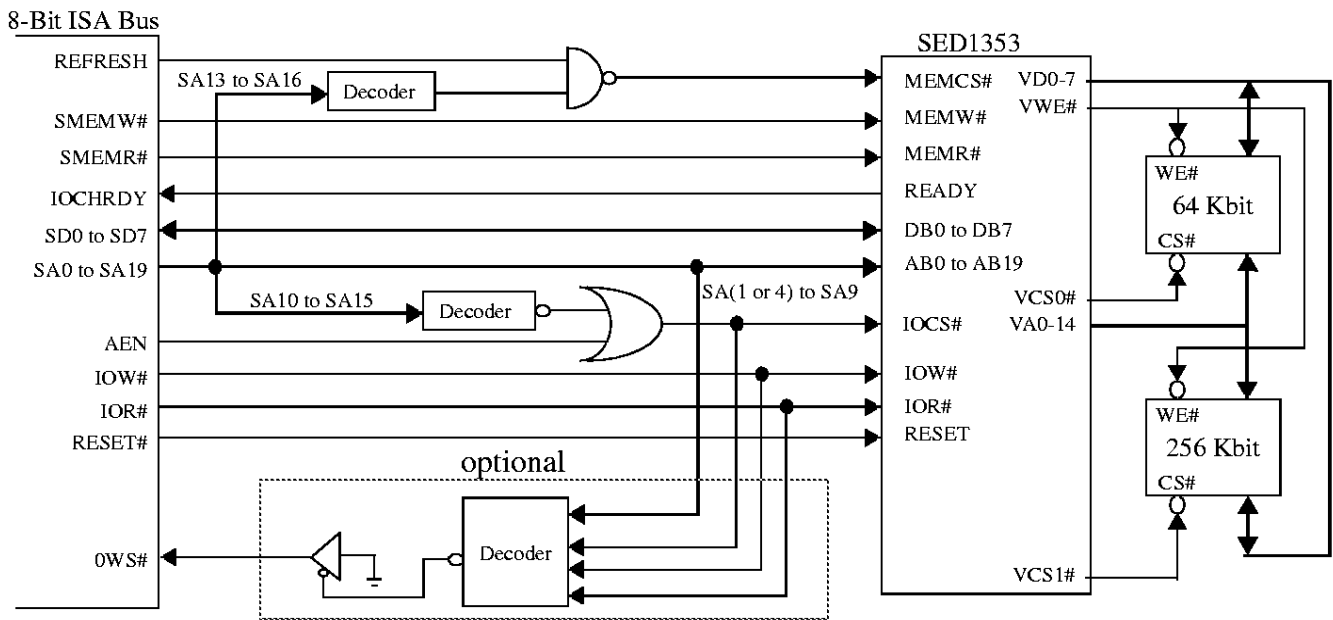

Note: Example implementation, actual may vary.

### Interface with 16-Bit ISA Bus and 128K bytes SRAM (1 of 128K x 8)

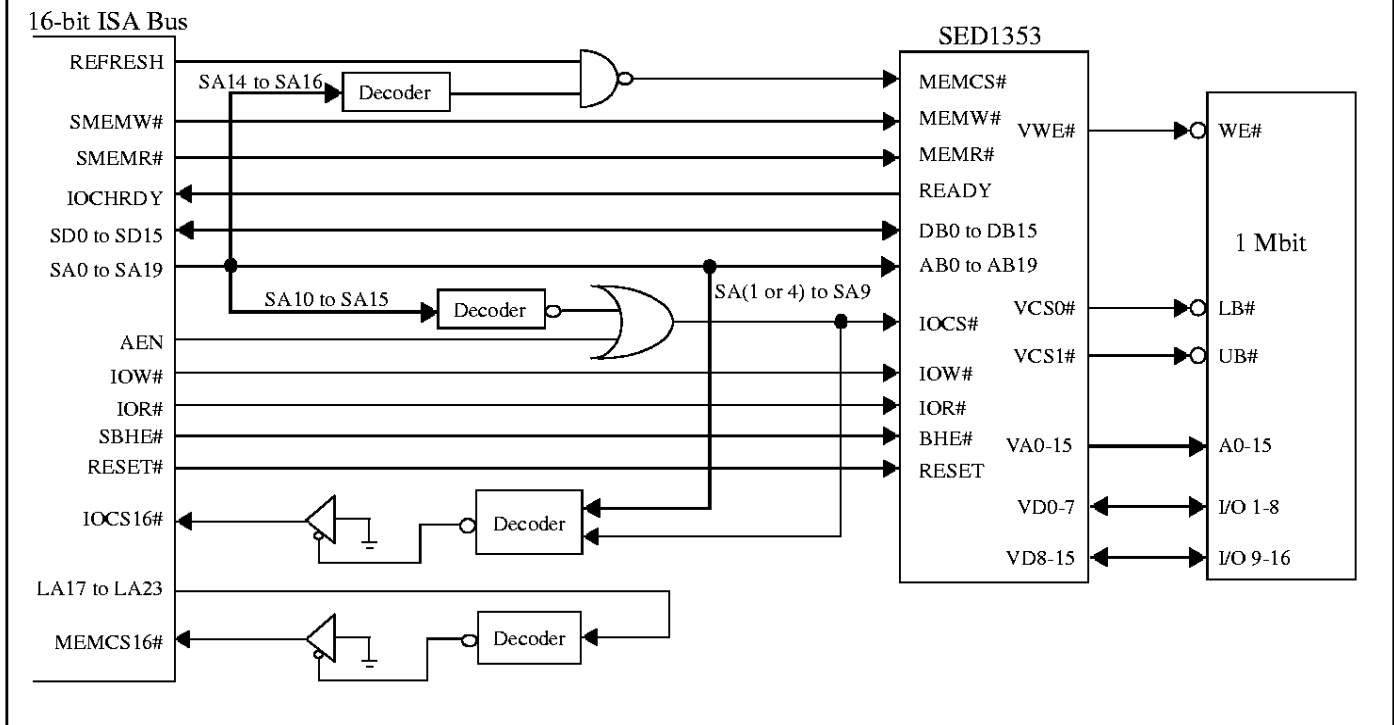

Note: Example implementation, actual may vary.

### SUPPORTED RESOLUTIONS

Display RAM	Example Display Size				SRAM Type	CPU Interface	SRAM Interface				
	Monochrome		4 Grays/ Colors					16 Grays/ Colors		256 Colors <sup>a</sup>	
	X	Y	X	Y				X	Y	X	Y
8K byte	320 x 200		256 x 128		128 x 128		—		1 of 8Kx8	8-bit	8-bit
16K byte	512 x 256		320 x 200		200 x 160		160 x 100 <sup>a</sup>		2 of 8Kx8	8-bit	8-bit/16-bit
										16-bit	16-bit
32K byte	512 x 512		512 x 256		256 x 256		192 x 100 <sup>a</sup>		1 of 32Kx8	8-bit	8-bit
40K byte	1024 x 320		512 x 320		320 x 256		320 x 128 <sup>a</sup>		1 of 8Kx8 and 1 of 32Kx8	8-bit	8-bit
64K byte	1024 x 512		512 x 512		512 x 256		256 x 256 <sup>a</sup>		2 of 32Kx8	8-bit	8-bit/16-bit
										16-bit	16-bit
128K byte	1024 x 1024		1024 x 512		512 x 512		512 x 256 <sup>a</sup>		1 of 64Kx16	16-bit	16-bit
										16-bit	16-bit

a. 256 colors must use 16-bit SRAM interface

The above listed display sizes are examples based on bits/pixel and available memory.

■ **BLOCK DIAGRAM**

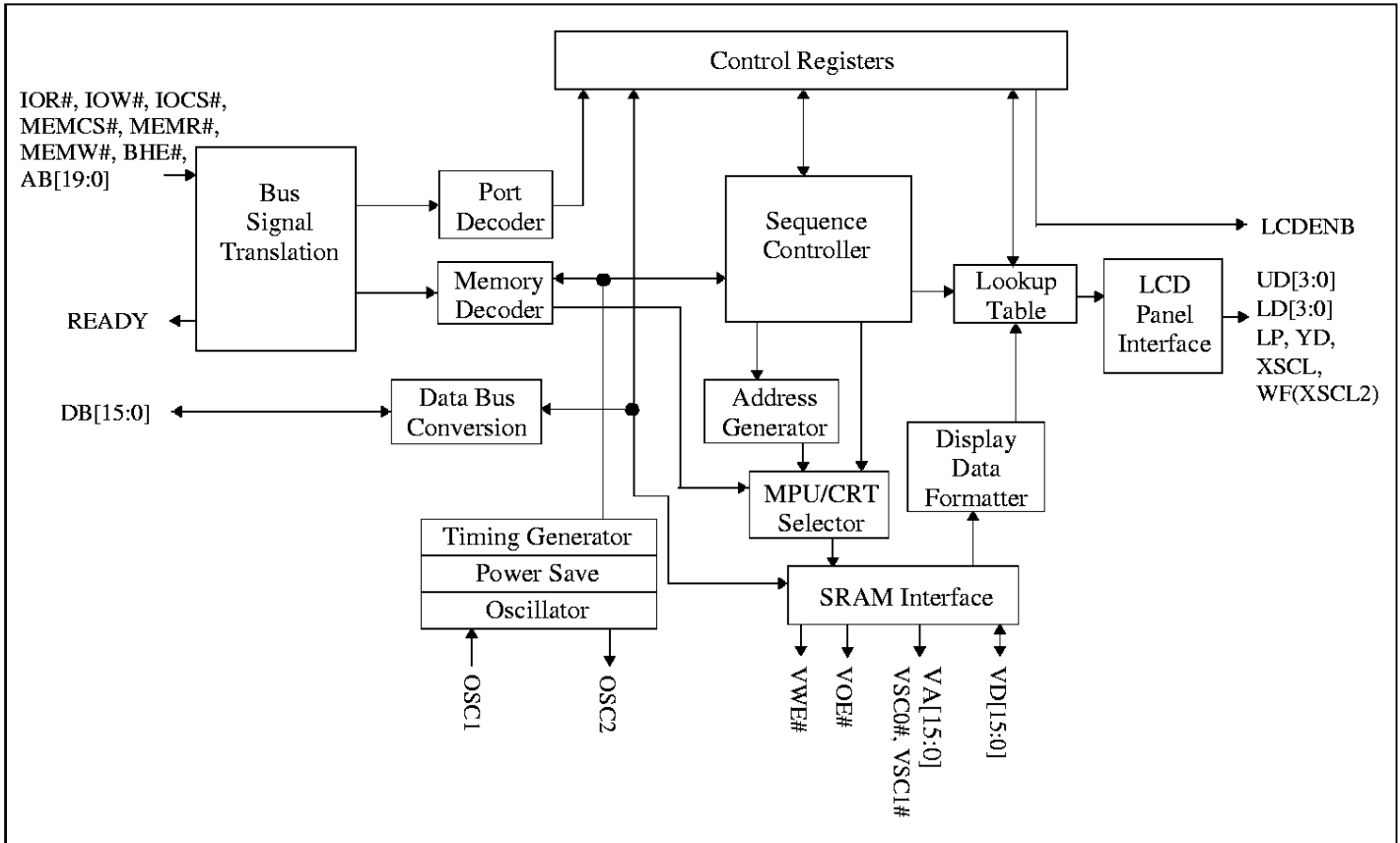

### ■ FUNCTIONAL BLOCK DESCRIPTION

#### Bus Signal Translation

According to configuration setting VD2, Bus Signal Translation translates either MC68000 type MPU signals or Ready type MPU signals to internal bus interface signals.

#### Control Registers

The Control Register contains 16 internal control and configuration registers. These registers can be accessed by either direct-mapping or using the built-in internal index register.

#### Sequence Controller

The Sequence Controller generates horizontal and vertical display timings according to the configuration registers settings.

#### LCD Panel Interface

The LCD Panel Interface performs frame rate modulation and output data pattern formatting for both passive monochrome and passive color LCD panels.

#### Look-Up Table

The Look-Up Table contains three 16x4-bit wide palettes. In gray shade modes, the "green" palette can be configured for the re-mapping of 16 possible shades of gray. In color modes, all three palettes can be configured for the re-mapping of 4096 possible colors.

#### Port Decoder

According to configuration settings VD1, VD12 - VD4, IOCS# and address lines AB9-1, the Port Decoder validates a given I/O cycle.

#### Memory Decoder

According to configuration settings VD15 - VD13, MEMCS# and address lines AB19-17, the Memory Decoder validates a given memory cycle.

#### Data Bus Conversion

According to configuration setting VD0, Data Bus Conversion maps the external data bus, either 8-bit or 16-bit, into the internal odd and even data bus.

#### Address Generator

The Address Generator generates display refresh addresses to be used to access display memory.

#### MPU / CRT Selector

The MPU / CRT Selector grants access to the display memory from either the MPU or the display refresh circuitry.

#### Display Data Formatter

The Display Data Formatter reads in the display data from the display memory and outputs the correct format for all supported gray shade and color selections.

#### Clock Inputs / Timing

Clock Inputs / Timing generates the internal master clock according to gray-level / color selected and display memory interface. The master clock (MCLK) can be:

- MCLK = input clock
- MCLK = 1/2 input clock
- MCLK = 1/4 input clock.

Pixel clock = input clock =  $f_{OSC}$ .

#### SRAM Interface

The SRAM Interface generates the necessary signals to interface to the Display Memory (SRAM).

■ **DC SPECIFICATIONS**

**Absolute Maximum Ratings**

Symbol	Parameter	Rating	Units
V <sub>DD</sub>	Supply Voltage	V <sub>SS</sub> - 0.3 to + 6.0	V
V <sub>IN</sub>	Input Voltage	V <sub>SS</sub> - 0.3 to V <sub>DD</sub> + 0.5	V
V <sub>OUT</sub>	Output Voltage	V <sub>SS</sub> - 0.3 to V <sub>DD</sub> + 0.5	V
T <sub>STG</sub>	Storage Temperature	-65 to 150	° C
T <sub>SOL</sub>	Solder Temperature/Time	260 for 10 sec. max at lead	° C

**Recommended Operating Conditions**

Symbol	Parameter	Condition	Min	Typ	Max	Units
V <sub>DD</sub>	Supply Voltage	V <sub>SS</sub> = 0 V	2.7	3.0/3.3/5.0	5.5	V
V <sub>IN</sub>	Input Voltage		V <sub>SS</sub>	--	V <sub>DD</sub>	V
I <sub>OPR</sub>	Operating Current	f <sub>OSC</sub> = 6 MHz 256 colors		4.5/5.0/11		mA
T <sub>OPR</sub>	Operating Temperature		-40	25	85	° C
P <sub>TYP</sub>	Typical Active Power Consumption	f <sub>OSC</sub> = 6 MHz 256 colors		13.5/16.5/55		mW

## SED1353

### Input Specifications

Symbol	Parameter	Condition	Min	Typ	Max	Units
$V_{IL}$	Low Level Input Voltage	$V_{DD} = 4.5V$ $V_{DD} = 3.0V$ $V_{DD} = 2.7V$			0.8 0.4 0.3	V
$V_{IH}$	High Level Input Voltage	$V_{DD} = 5.5V$ $V_{DD} = 3.6V$ $V_{DD} = 3.3V$	2.0 1.3 1.2			V
$V_{T+}$	Positive-going Threshold	$V_{DD} = 5.0$ $V_{DD} = 3.3$ $V_{DD} = 3.0$			2.4 1.4 1.3	V
$V_{T-}$	Negative-going Threshold	$V_{DD} = 5.0$ $V_{DD} = 3.3$ $V_{DD} = 3.0$	0.6 0.5 0.4			V
$V_H$	Hysteresis Voltage	$V_{DD} = 5.0$ $V_{DD} = 3.3$ $V_{DD} = 3.0$	0.1 0.1 0.1			V
$I_{IZ}$	Input Leakage Current	--	-1		1	$\mu A$
$C_{IN}$	Input Pin Capacitance	$f = 1 \text{ MHz}$ , $V_{DD} = 0V$			12	pF
$R_{PD}$	Pull Down Resistance	$V_{DD} = 5.0V$ $V_I = V_{DD}$	50	100	200	k $\Omega$
$R_{PD}$	Pull Down Resistance	$V_{DD} = 3.3V$ $V_I = V_{DD}$	90	180	360	k $\Omega$
$R_{PD}$	Pull Down Resistance	$V_{DD} = 3.0V$ $V_I = V_{DD}$	100	200	400	k $\Omega$

**Output Specifications**

Symbol	Parameter	Condition	Min	Typ	Max	Units
$V_{OL(5.0V)}$	Low Level Output Voltage Type 1 - TS1D2, CO1 Type 2 - TS2, CO2 Type 3 - TS3, CO3, CO3S	$V_{DD} = \text{Min}$ $I_{OL} = 4 \text{ mA}$ $I_{OL} = 8 \text{ mA}$ $I_{OL} = 12 \text{ mA}$			0.4	V
$V_{OL(3.3V)}$	Low Level Output Voltage Type 1 - TS1D2, CO1 Type 2 - TS2, CO2 Type 3 - TS3, CO3, CO3S	$V_{DD} = \text{Min}$ $I_{OL} = 2 \text{ mA}$ $I_{OL} = 4 \text{ mA}$ $I_{OL} = 6 \text{ mA}$			0.3	V
$V_{OL(3.0V)}$	Low Level Output Voltage Type 1 - TS1D2, CO1 Type 2 - TS2, CO2 Type 3 - TS3, CO3, CO3S	$V_{DD} = \text{Min}$ $I_{OL} = 1.8 \text{ mA}$ $I_{OL} = 3.5 \text{ mA}$ $I_{OL} = 5 \text{ mA}$			0.3	V
$V_{OH(5.0V)}$	High Level Output Voltage Type 1 - TS1D2, CO1 Type 2 - TS2, CO2 Type 3 - TS3, CO3, CO3S	$V_{DD} = \text{Min}$ $I_{OH} = -4 \text{ mA}$ $I_{OH} = -8 \text{ mA}$ $I_{OH} = -12 \text{ mA}$	$V_{DD}-0.4$			V
$V_{OH(3.3V)}$	Low Level Output Voltage Type 1 - TS1D2, CO1 Type 2 - TS2, CO2 Type 3 - TS3, CO3, CO3S	$V_{DD} = \text{Min}$ $I_{OL} = -2 \text{ mA}$ $I_{OL} = -4 \text{ mA}$ $I_{OL} = -6 \text{ mA}$	$V_{DD}-0.3$			V
$V_{OH(3.0V)}$	High Level Output Voltage Type 1 - TS1D2, CO1 Type 2 - TS2, CO2 Type 3 - TS3, CO3, CO3S	$V_{DD} = \text{Min}$ $I_{OH} = -1.8 \text{ mA}$ $I_{OH} = -3.5 \text{ mA}$ $I_{OH} = -5 \text{ mA}$	$V_{DD}-0.3$			V
$I_{OZ}$	Output Leakage Current	--	-1		1	$\mu\text{A}$
$C_{OUT}$	Output Pin Capacitance	$f = 1 \text{ MHz}$ , $V_{DD} = 0\text{V}$			12	pF
$C_{BID}$	Bidirectional Pin Capacitance	$f = 1 \text{ MHz}$ , $V_{DD} = 0\text{V}$			12	pF

## SED1353

### ■ SED1353F0A PIN OUT

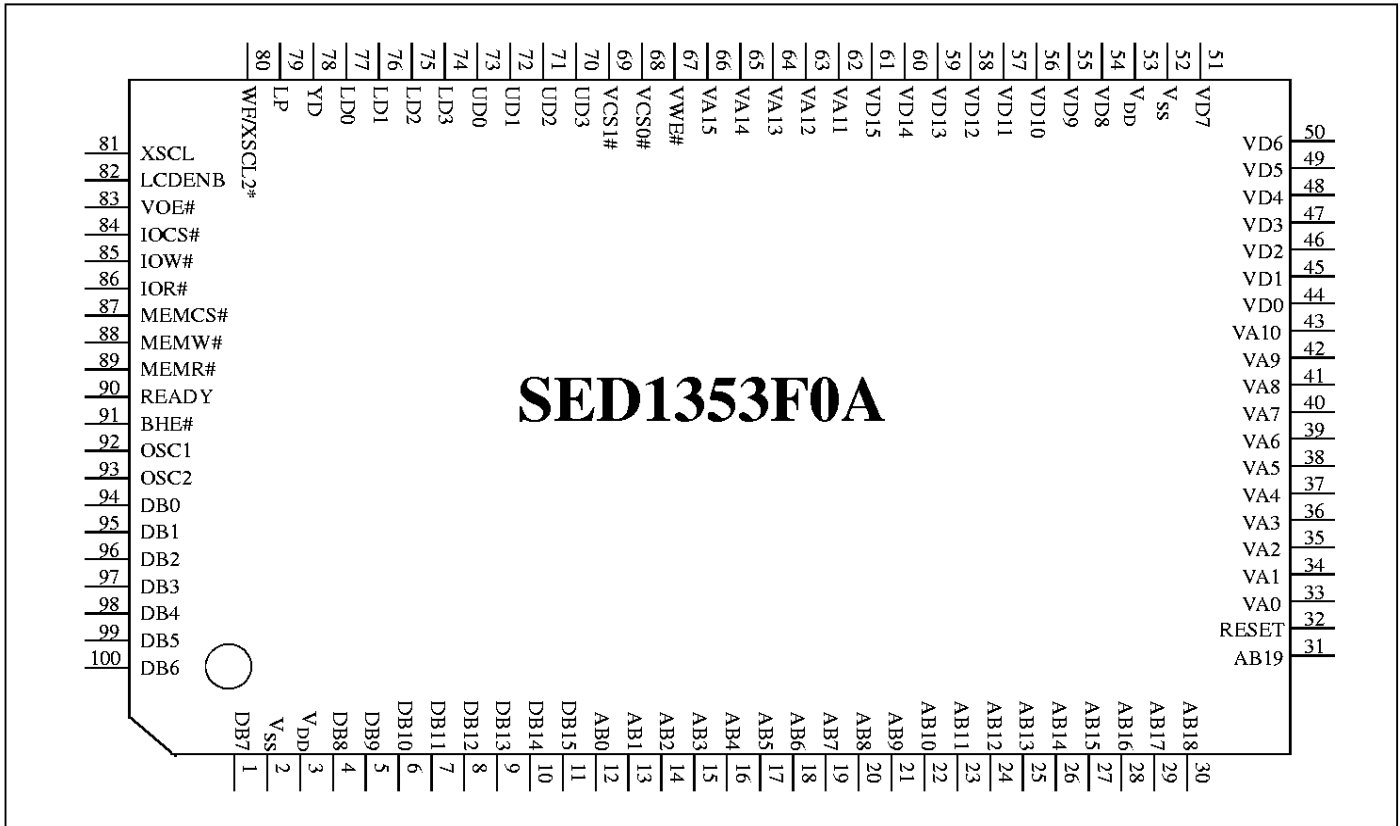

\* Pin 80 = WF in all display modes except format 1 for 8-bit single color panel.

\* Pin 80 = XSCL2 in format 1 for 8-bit single color panel.



■ **SED1353F1A PIN OUT**

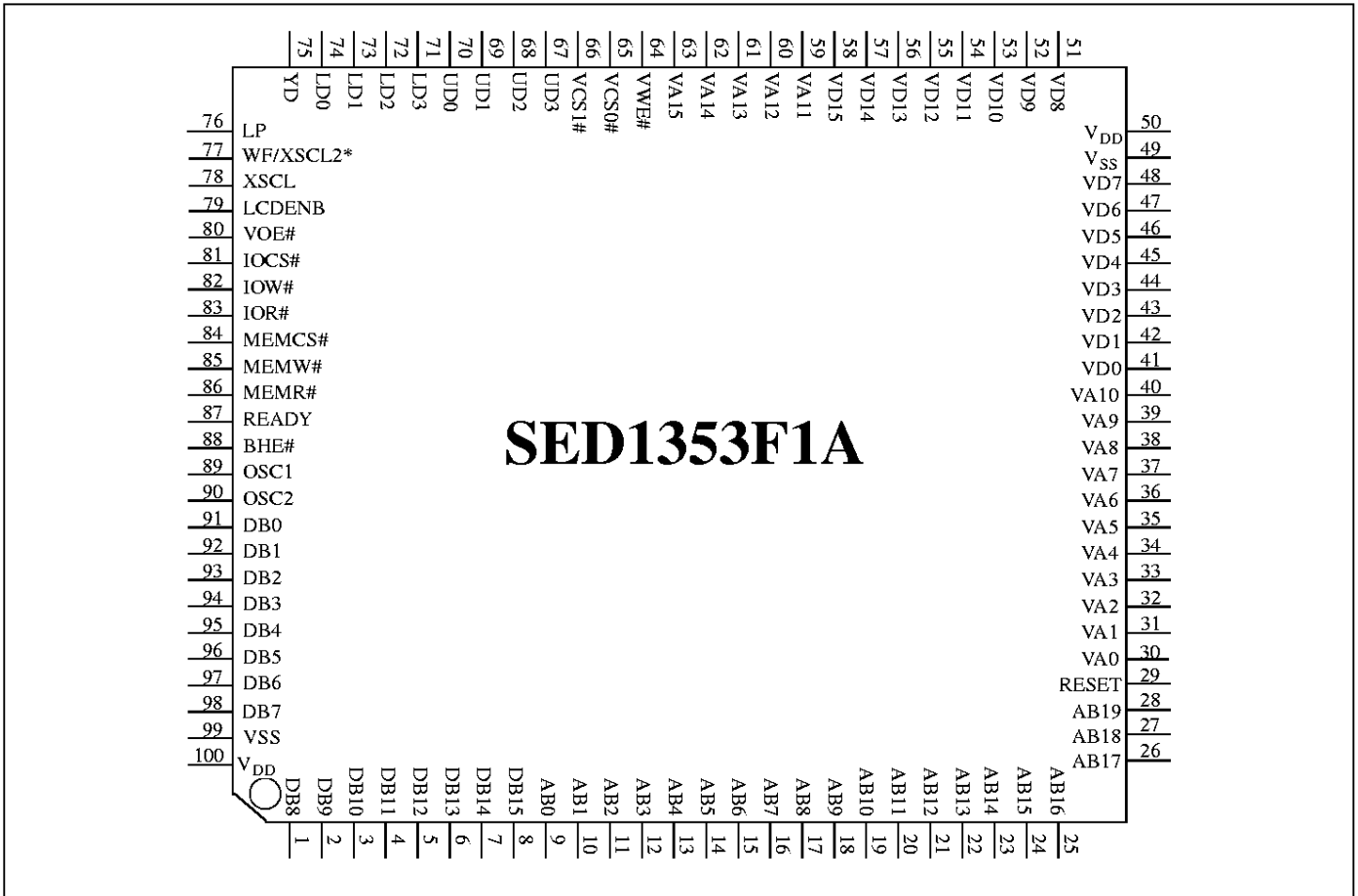

- \* Pin 77 = WF in all display modes except format 1 for 8-bit single color panel.
- \* Pin 77 = XSCL2 in format 1 for 8-bit single color panel.

## SED1353

### ■ SED1353D0A PIN OUT

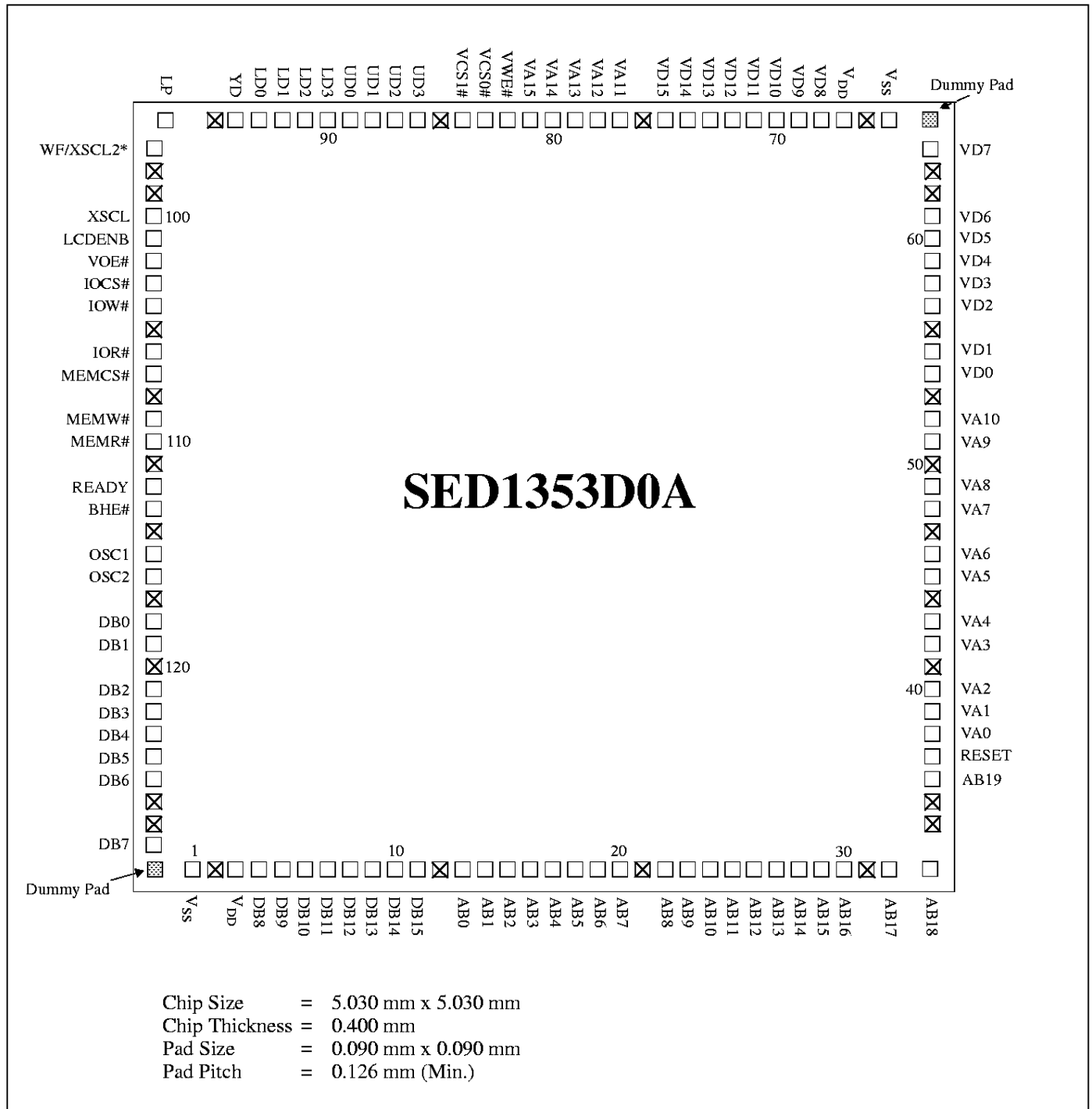

\* Pad 97 = WF in all display modes except format 1 for 8-bit single color panel.

\* Pad 97 = XSCL2 in format 1 for 8-bit single color panel.

**PAD Coordinates**

Pad No.	Pin Name	Pad Center Coordinate	
		X	Y
1	VSS	-2.165	-2.390
2	---	-2.000	-2.390
3	VDD	-1.840	-2.390
4	DB8	-1.685	-2.390
5	DB9	-1.535	-2.390
6	DB10	-1.388	-2.390
7	DB11	-1.246	-2.390
8	DB12	-1.106	-2.390
9	DB13	-0.969	-2.390
10	DB14	-0.835	-2.390
11	DB15	-0.703	-2.390
12	---	-0.573	-2.390
13	AB0	-0.444	-2.390
14	AB1	-0.317	-2.390
15	AB2	-0.190	-2.390
16	AB3	-0.063	-2.390
17	AB4	0.063	-2.390
18	AB5	0.190	-2.390
19	AB6	0.317	-2.390
20	AB7	0.444	-2.390
21	---	0.573	-2.390
22	AB8	0.703	-2.390
23	AB9	0.835	-2.390
24	AB10	0.969	-2.390
25	AB11	1.106	-2.390
26	AB12	1.246	-2.390
27	AB13	1.388	-2.390
28	AB14	1.535	-2.390
29	AB15	1.685	-2.390
30	AB16	1.840	-2.390
31	---	2.000	-2.390
32	AB17	2.165	-2.390
33	AB18	2.390	-2.340
34	---	2.390	-2.000
35	---	2.390	-1.840
36	AB19	2.390	-1.685

Pad No.	Pin Name	Pad Center Coordinate	
		X	Y
37	RESET	2.390	-1.535
38	VA0	2.390	-1.388
39	VA1	2.390	-1.246
40	VA2	2.390	-1.106
41	---	2.390	-0.969
42	VA3	2.390	-0.835
43	VA4	2.390	-0.703
44	---	2.390	-0.573
45	VA5	2.390	-0.444
46	VA6	2.390	-0.317
47	---	2.390	-0.190
48	VA7	2.390	-0.063
49	VA8	2.390	0.063
50	---	2.390	0.190
51	VA9	2.390	0.317
52	VA10	2.390	0.444
53	---	2.390	0.573
54	VD0	2.390	0.703
55	VD1	2.390	0.835
56	---	2.390	0.969
57	VD2	2.390	1.106
58	VD3	2.390	1.246
59	VD4	2.390	1.388
60	VD5	2.390	1.535
61	VD6	2.390	1.685
62	---	2.390	1.840
63	---	2.390	2.000
64	VD7	2.390	2.165
65	VSS	2.165	2.390
66	---	2.000	2.390
67	VDD	1.840	2.390
68	VD8	1.685	2.390
69	VD9	1.535	2.390
70	VD10	1.388	2.390
71	VD11	1.246	2.390
72	VD12	1.106	2.390

Pad No.	Pin Name	Pad Center Coordinate	
		X	Y
73	VD13	0.969	2.390
74	VD14	0.835	2.390
75	VD15	0.703	2.390
76	---	0.573	2.390
77	VA11	0.444	2.390
78	VA12	0.317	2.390
79	VA13	0.190	2.390
80	VA14	0.063	2.390
81	VA15	-0.063	2.390
82	VWE#	-0.190	2.390
83	VCS0#	-0.317	2.390
84	VCS1#	-0.444	2.390
85	---	-0.573	2.390
86	UD3	-0.703	2.390
87	UD2	-0.835	2.390
88	UD1	-0.969	2.390
89	UD0	-1.106	2.390
90	LD3	-1.246	2.390
91	LD2	-1.388	2.390
92	LD1	-1.535	2.390
93	LD0	-1.685	2.390
94	YD	-1.840	2.390
95	---	-2.000	2.390
96	LP	-2.340	2.390
97	WF/XSCL2	-2.390	2.165
98	---	-2.390	2.000
99	---	-2.390	1.840
100	XSCL	-2.390	1.685
101	LCDENB	-2.390	1.535

Pad No.	Pin Name	Pad Center Coordinate	
		X	Y
102	VOE#	-2.390	1.388
103	IOCS#	-2.390	1.246
104	IOW#	-2.390	1.106
105	---	-2.390	0.969
106	IOR#	-2.390	0.835
107	MEMCS#	-2.390	0.703
108	---	-2.390	0.573
109	MEMW#	-2.390	0.444
110	MEMR#	-2.390	0.317
111	---	-2.390	0.190
112	READY	-2.390	0.063
113	BHE#	-2.390	-0.063
114	---	-2.390	-0.190
115	OSC1	-2.390	-0.317
116	OSC2	-2.390	-0.444
117	---	-2.390	-0.573
118	DB0	-2.390	-0.703
119	DB1	-2.390	-0.835
120	---	-2.390	-0.969
121	DB2	-2.390	-1.106
122	DB3	-2.390	-1.246
123	DB4	-2.390	-1.388
124	DB5	-2.390	-1.535
125	DB6	-2.390	-1.685
126	---	-2.390	-1.840
127	---	-2.390	-2.000
128	DB7	-2.390	-2.165
129	Dummy Pad	2.390	2.390
130	Dummy Pad	-2.390	-2.390

■ **PIN DESCRIPTION**

**Key**

- I = Input
- O = Output
- I/O = Bidirectional
- P = Power

**Bus Interface**

Pin Name	Type	F0A Pin #	F1A Pin #	D0A Pad #	Description
DB0-DB15	I/O	94 - 100, 1, 4 - 11	91 - 98, 1 - 8	118-119, 121-125, 128, 4-11	These pins are connected to the system data bus. In 8-bit bus mode, DB8-DB15 must be tied to $V_{DD}$ .
AB0	I	12	9	13	In MC68000 MPU interface, this pin is connected to the Upper Data Strobe (UDS#) pin of MC68000. In other bus interfaces, this pin is connected to the system address bus.
AB1-AB19	I	13 - 31	10 - 28	14-20, 22-30, 32-33, 36	These pins are connected to the system address bus.
BHE#	I	91	88	113	In MC68000 MPU interface, this pin is connected to the Lower Data Strobe (LDS#) pin of MC68000. In other bus interfaces, this pin is the Byte High Enable input for use with 16-bit system. In 8-bit bus mode, tie BHE# input to $V_{DD}$ .
IOCS#	I	84	81	103	Active low input to select one of fifteen internal registers.
IOW#	I	85	82	104	In MC68000 MPU interface, this pin is connected to the R/W# pin of MC68000. This input pin will define whether the data transfer is a read (active high) or write (active low) cycle. In other bus interfaces, this is the active low input to write data into an internal register.
IOR#	I	86	83	106	In MC68000 MPU interface, this pin is connected to the AS# pin of MC68000. This input pin will indicate a valid address is available on the address bus. In other bus interfaces, this is the active low input to read data from an internal register.
MEMCS#	I	87	84	107	Active low input to indicate the attempt to access the display memory.
MEMW#	I	88	85	109	Active low input to write data to the display memory. This pin should be tied to $V_{DD}$ in an MC68000 MPU interface.
MEMR#	I	89	86	110	Active low input to read data from the display memory. This pin should be tied to $V_{DD}$ in an MC68000 MPU interface.
READY	O	90	87	112	For MC68000 MPU interface, this pin is connected to the DTACK# pin of MC68000 and will be driven low when ever a data transfer is complete. In other bus interfaces, this output is driven low to force the system to insert wait states when needed.  READY is placed in a high-impedance (Hi-Z) state after the transfer is completed.
RESET	I	32	29	37	Active high input to force all signals to their inactive states.

## SED1353

### Display Memory Interface

Pin Name	Type	F0A Pin #	F1A Pin #	D0A Pad #	Description
VD0-VD15	I/O	44 - 51, 54 - 61	41 - 48, 51 - 58	54-55, 57-61, 64, 68-75	These pins are connected to the display memory data bus. For 16-bit interface, VD0-VD7 are connected to the display memory data bus of even byte addresses and VD8-VD15 are connected to the display memory data bus of odd byte addresses. The output drivers of these pins are tri-stated when RESET is high.  On the falling edge of RESET the values of VD0-VD15 are latched into the chip to configure various hardware options.
VA0-VA15	O	33 - 43, 62 - 66	30 - 40 59 - 63	38-40, 42-43, 45-46, 48-49, 51-52, 77-81	These pins are connected to the display memory address bus.
VCS1#	O	69	66	84	Active low chip-select output to the second or odd byte address SRAM.
VCS0#	O	68	65	83	Active low chip-select output to the first or even byte address SRAM.
VWE#	O	67	64	82	Active low output used for writing data to the display memory. This pin is connected to the WE# input of the SRAMs.
VOE#	O	83	80	102	Active low output to enable reading of data from the display memory. This pin is connected to the OE# input of the SRAMs.

### LCD Interface

Pin Name	FPDI-1™ Pin Name <sup>a</sup>	Type	F0A Pin #	F1A Pin #	D0A Pad #	Description
UD3-UD0 LD3-LD0	UD3-UD0 LD3-LD0	O	70 - 73 74 - 77	67 - 70 71 - 74	86 - 89 90 - 93	Panel display data bus. The data format depends on the specific panel connected. For 4-bit single panels, these bits are driven 0 (low state).
XSCL	FPSHIFT	O	81	78	100	Display data shift clock. Data is shifted into the LCD X-drivers on the falling edge of this signal.
LP	FPLINE	O	79	76	96	Display data latch clock. The falling edge of this signal is used to latch a row of display data in the LCD X-drivers and to turn on the row driver (Y driver).
WF/XSCL2	MOD FPSHIFT2	O	80	77	97	For format 1 of 8-bit single color panels this is the second shift clock. For all other modes, this is the LCD backplane BIAS signal. This output toggles once every n LP periods, as programmed in AUX[05]
YD	FPFRAME	O	78	75	94	Vertical scanning start pulse. A logic '1' on this signal, sampled by the LCD module on the falling edge of LP, is used by the panel row driver (Y driver) to indicate the start of the vertical frame.
LCDENB	---	O	82	79	101	LCD enable signal output. It can be used externally to turn off the panel supply voltage and backlight.

a. VESA Flat Panel Display Interface Standard (FPDI-1™)

**Clock Inputs**

Pin Name	Type	F0A Pin #	F1A Pin #	D0A Pad #	Description
OSC1	I	92	89	115	This pin, along with OSC2 is the 2-terminal crystal interface when using a 2-terminal crystal as the clock input. If an external oscillator is used as a clock source, then this pin is the clock input.
OSC2	O	93	90	116	This pin, along with OSC1 is the 2-terminal crystal interface when using a 2-terminal crystal as the clock input. If an external oscillator is used as a clock source, then this pin should be left unconnected.

**Power Supply**

Pin Name	Type	F0A Pin #	F1A Pin #	D0A Pad #	Description
V <sub>DD</sub>	P	3, 53	50, 100	3, 67	Voltage supply.
V <sub>SS</sub>	P	2, 52	49, 99	1, 65	Voltage Ground.

**■ SUMMARY OF CONFIGURATION OPTIONS**

Pin Name	value on this pin at falling edge of RESET is used to configure: (1/0)	
	<b>1</b>	<b>0</b>
VD0	16-bit host bus interface	8-bit host bus interface
VD1	Use direct-mapping for I/O accesses	Use indexed mapping for I/O accesses
VD2	MC68000 MPU interface	MPU / Bus interface with memory accesses controlled by a READY (WAIT#) signal
VD3	Swap of high and low data bytes in 16-bit bus interface	No byte swap of high and low data bytes in 16-bit bus interface
VD12-VD4	Select I/O mapping address bits [9:1]. These nine bits are latched on power-up and are compared to the MPU address bits [9-1]. A valid I/O cycle combined with a valid address will enable the internal I/O decoder. Therefore, both types of I/O mapping are limited to even address boundaries to determine either the absolute or indexed I/O address of the first register. Note that a "valid I/O cycle" includes IOCS# being toggled low.	
VD15-VD13	Select memory mapping address bits [3:1] These three bits are latched on power-up and are compared to the MPU address bits [19-17]. A valid memory cycle combined with a valid address will enable the internal memory decoder. As only the three most significant bits of the address are compared, the maximum amount of memory supported is 128K bytes. Note that a "valid memory cycle" includes MEMCS# being toggled low. When using 128K byte memory it must be mapped at an even address such that all 128K bytes is available without a change in state on A17, as this would invalidate the internal compare logic.	

## SED1353

Example: If an ISA bus (no byte swap) with memory segment "A" and I/O location 300h are used, the corresponding settings of VD15-VD0 would be:

Pin Name	8-Bit ISA Bus		16-Bit ISA Bus	
	Index Register	Direct Mapping	Index Register	Direct Mapping
VD0	0	0	1	1
VD1	0	1	0	1
VD2	0	0	0	0
VD3	0	0	0	0
VD12-VD4	11 0000 000	11 0000 xxx	11 0000 000	11 0000 xxx
VD15-VD13	101	101	101	101

Where x = don't care; 1 = connected to pull-up resistor; 0 = not connected to pull-up resistor



■ **MONOCHROME PASSIVE STN LCD PANEL INTERFACE**

**4-Bit Single Panel**

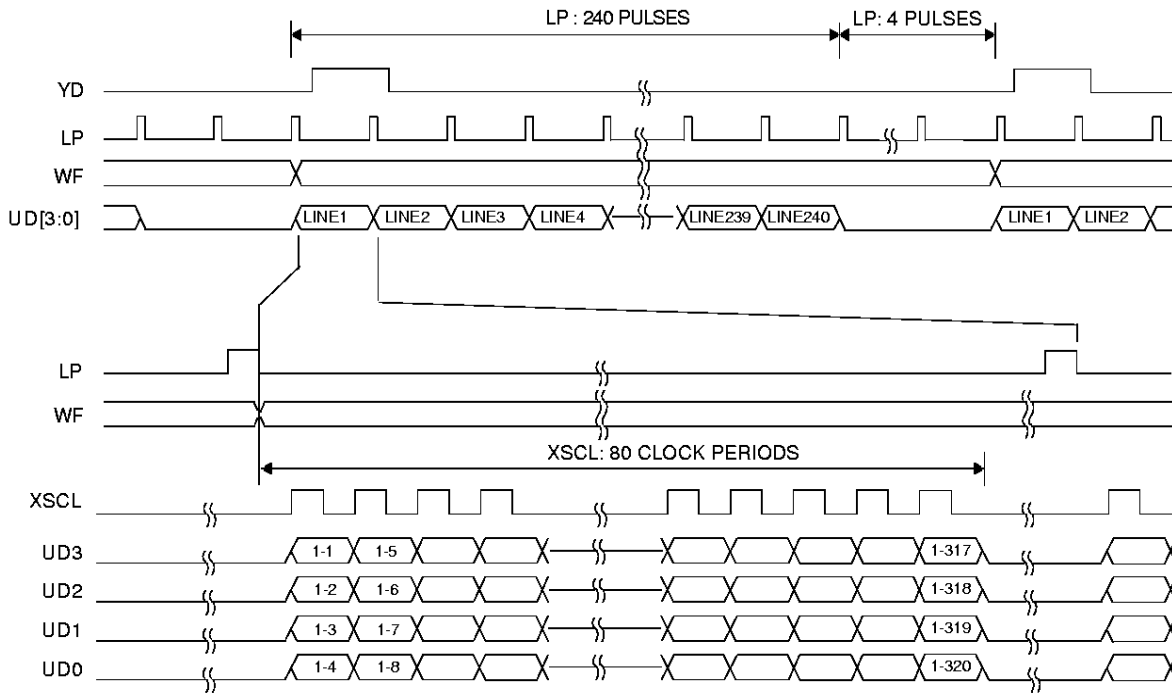

Example Timing for a 320x240 single panel

## SED1353

### MONOCHROME PASSIVE STN LCD PANEL INTERFACE

#### 8-Bit Single Panel

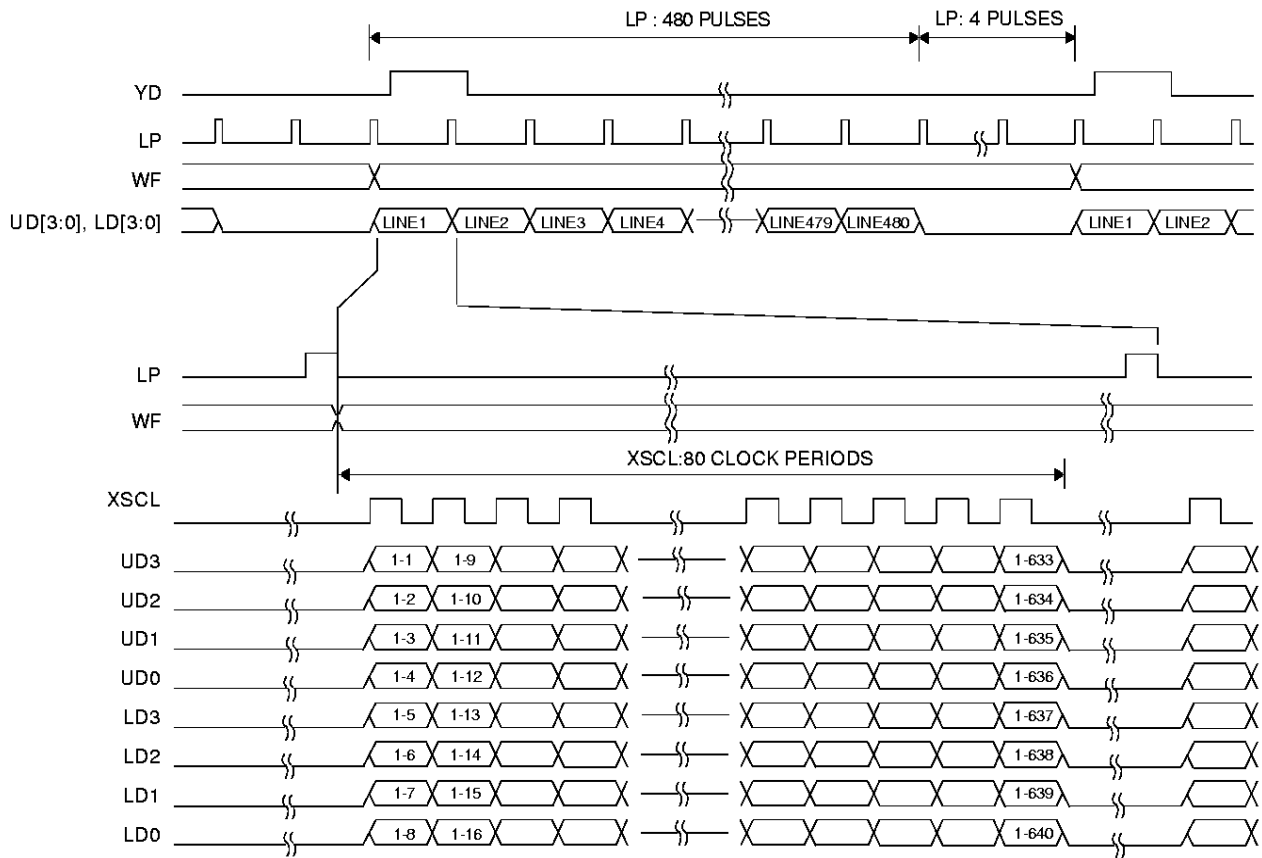

Example timing for a 640x480 panel

■ **MONOCHROME PASSIVE STN LCD PANEL INTERFACE**

**8-Bit Dual Panel**

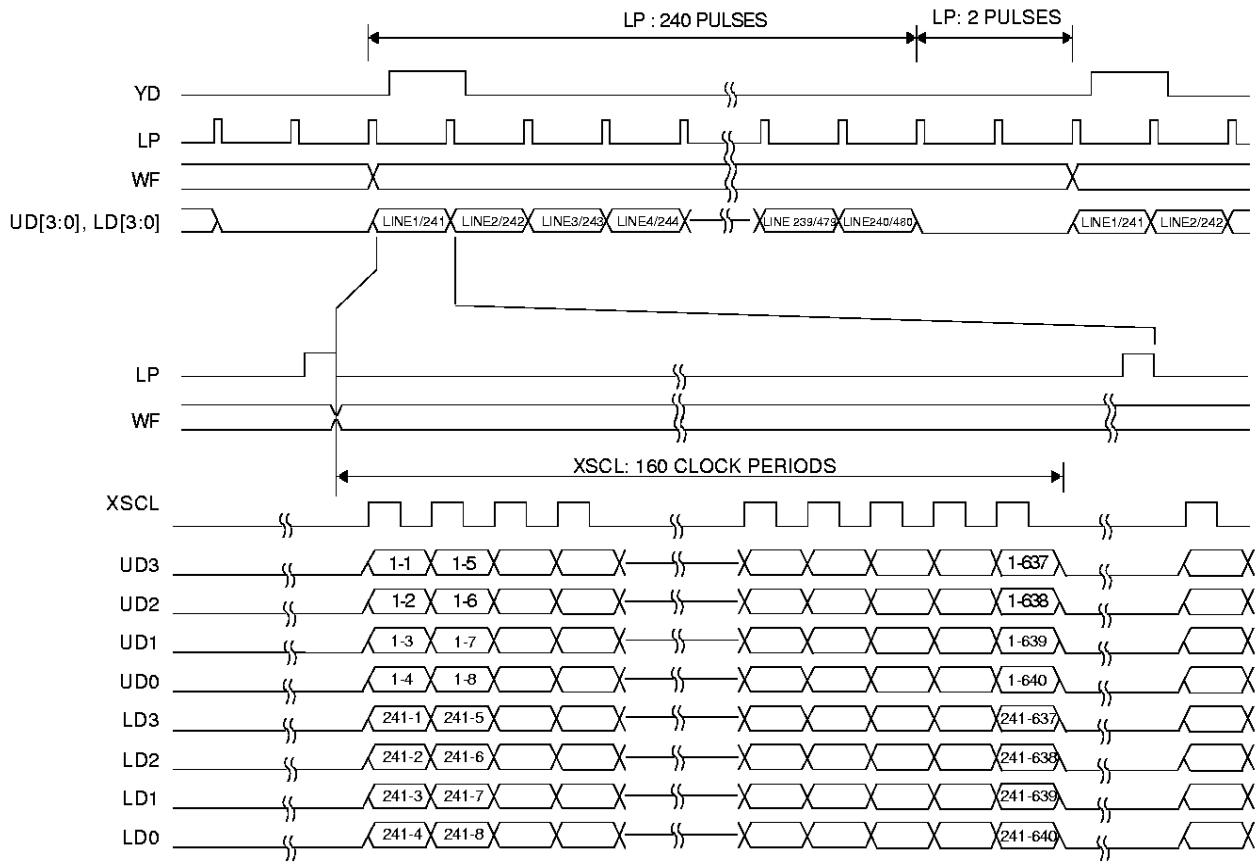

Example timing for a 640x480 panel

### ■ COLOR PASSIVE STN LCD PANEL INTERFACE

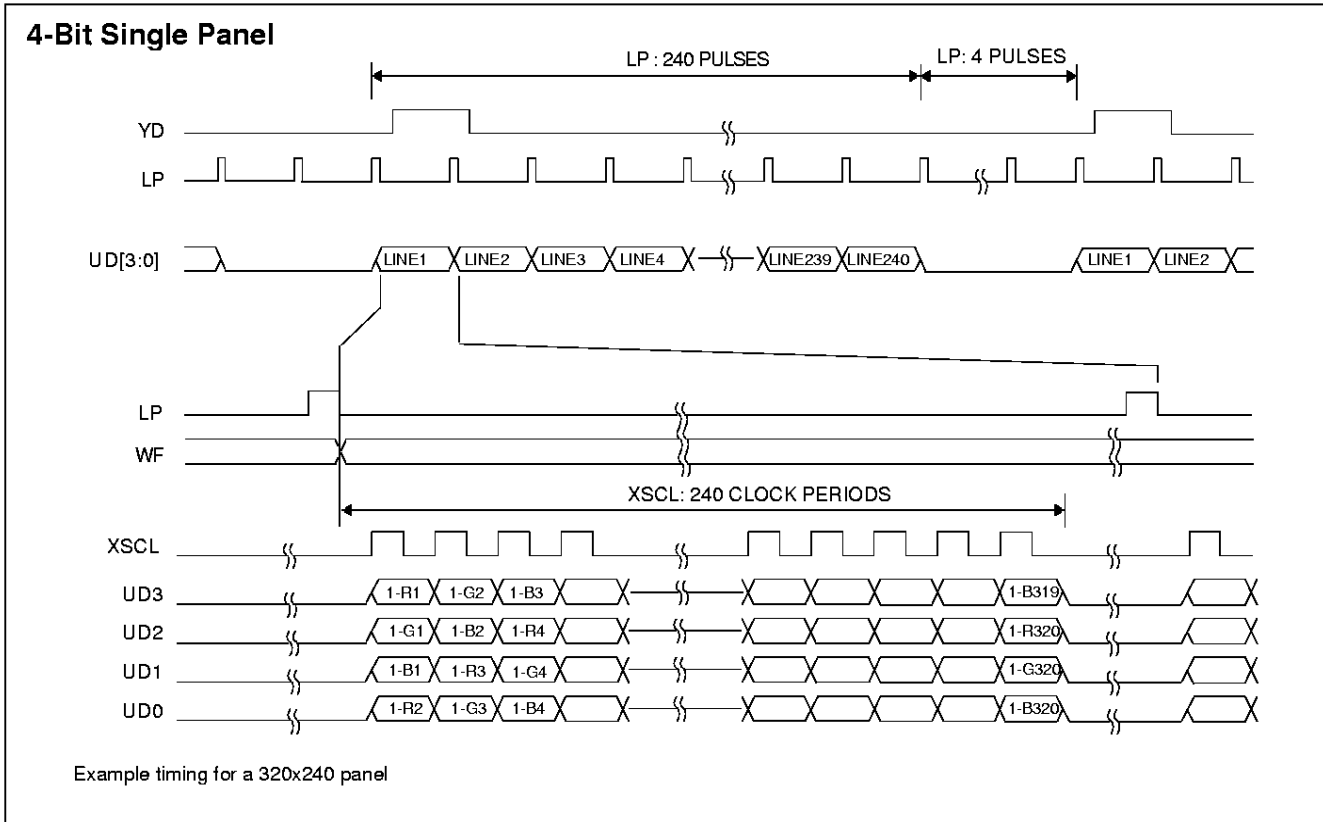

■ **COLOR PASSIVE STN LCD PANEL INTERFACE**

**8-Bit Single Panel - Format 1**

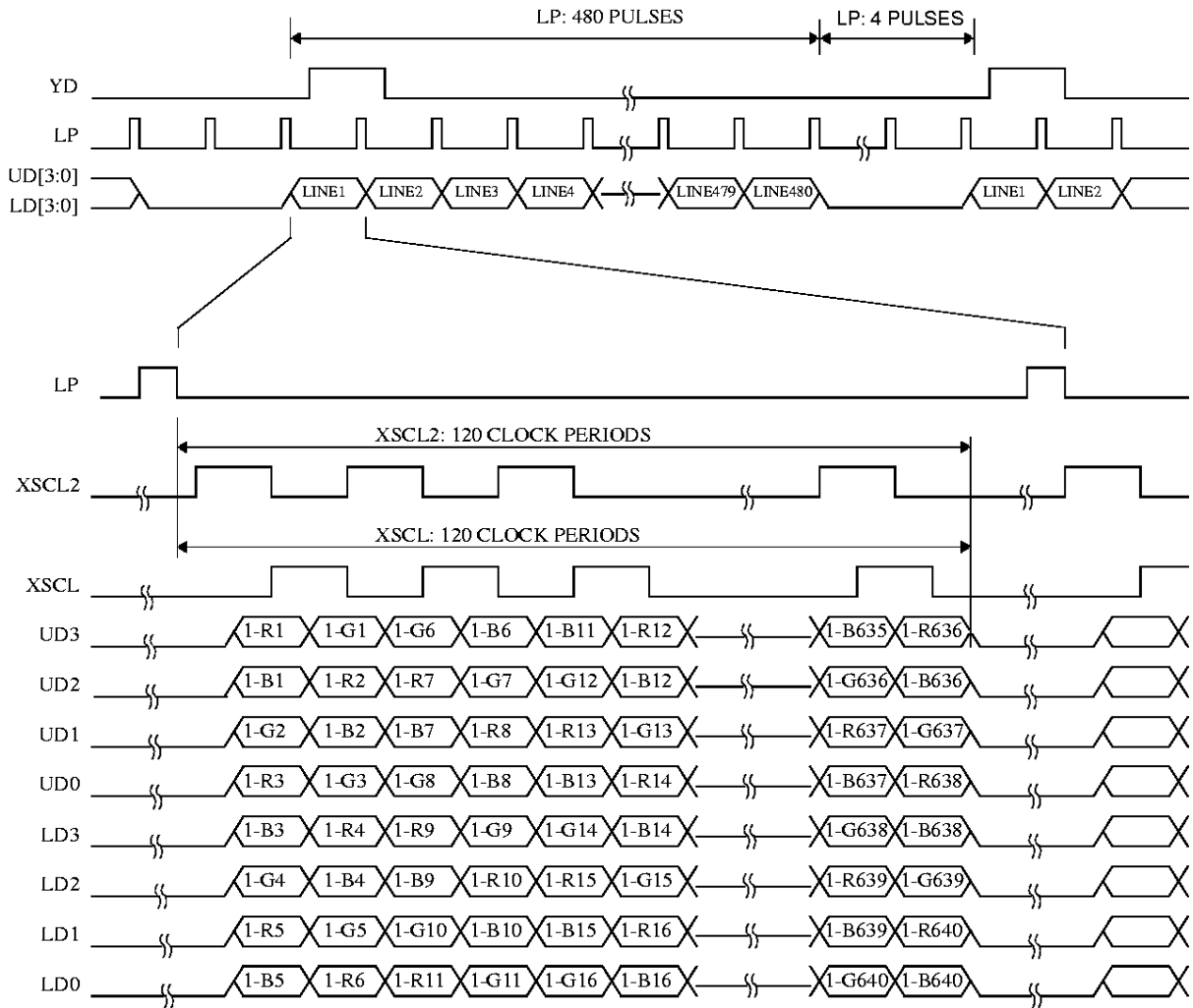

Example timing for a 640x480 panel

### ■ COLOR PASSIVE STN LCD PANEL INTERFACE

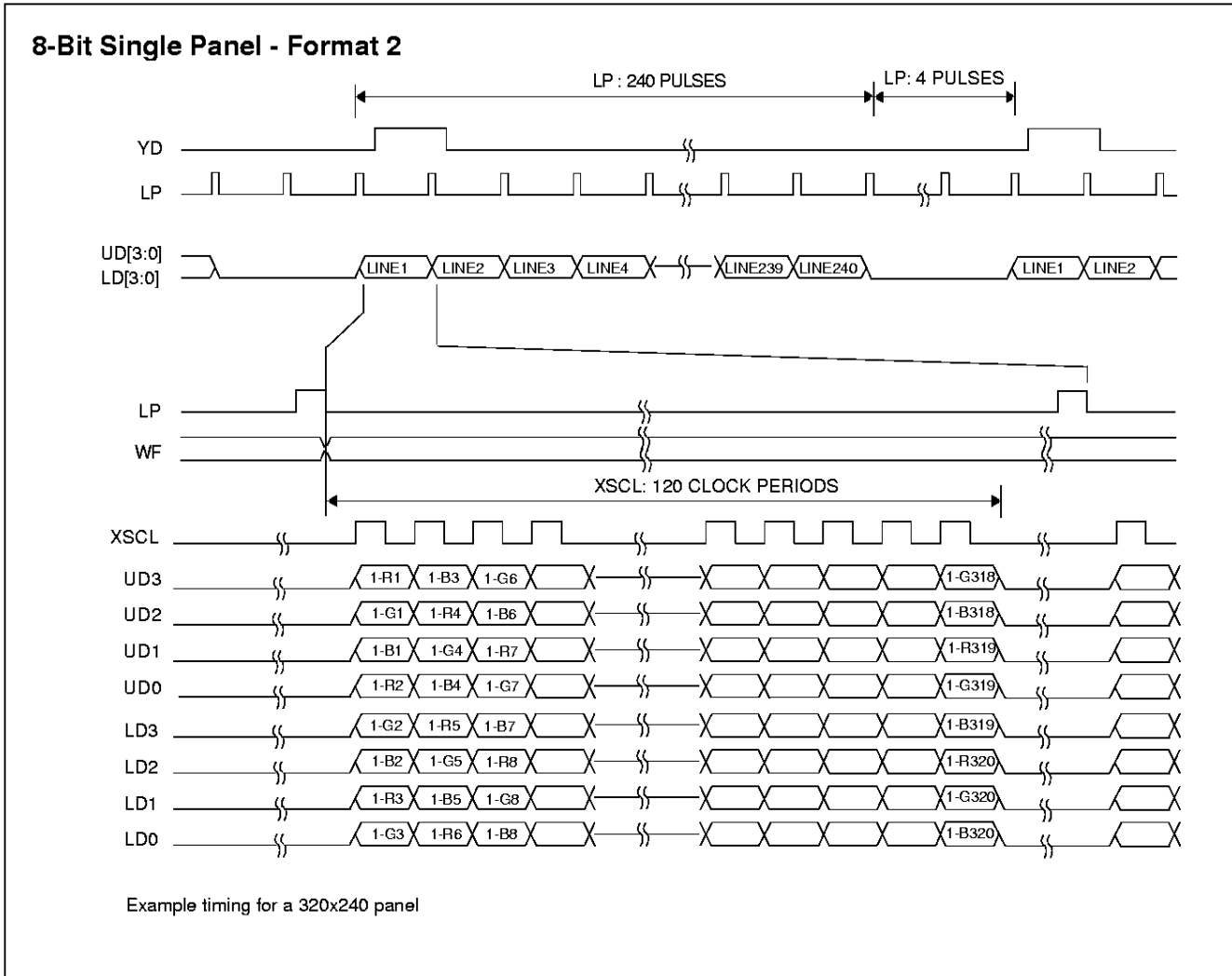

■ **COLOR PASSIVE STN LCD PANEL INTERFACE**

**8-Bit Dual Panel**

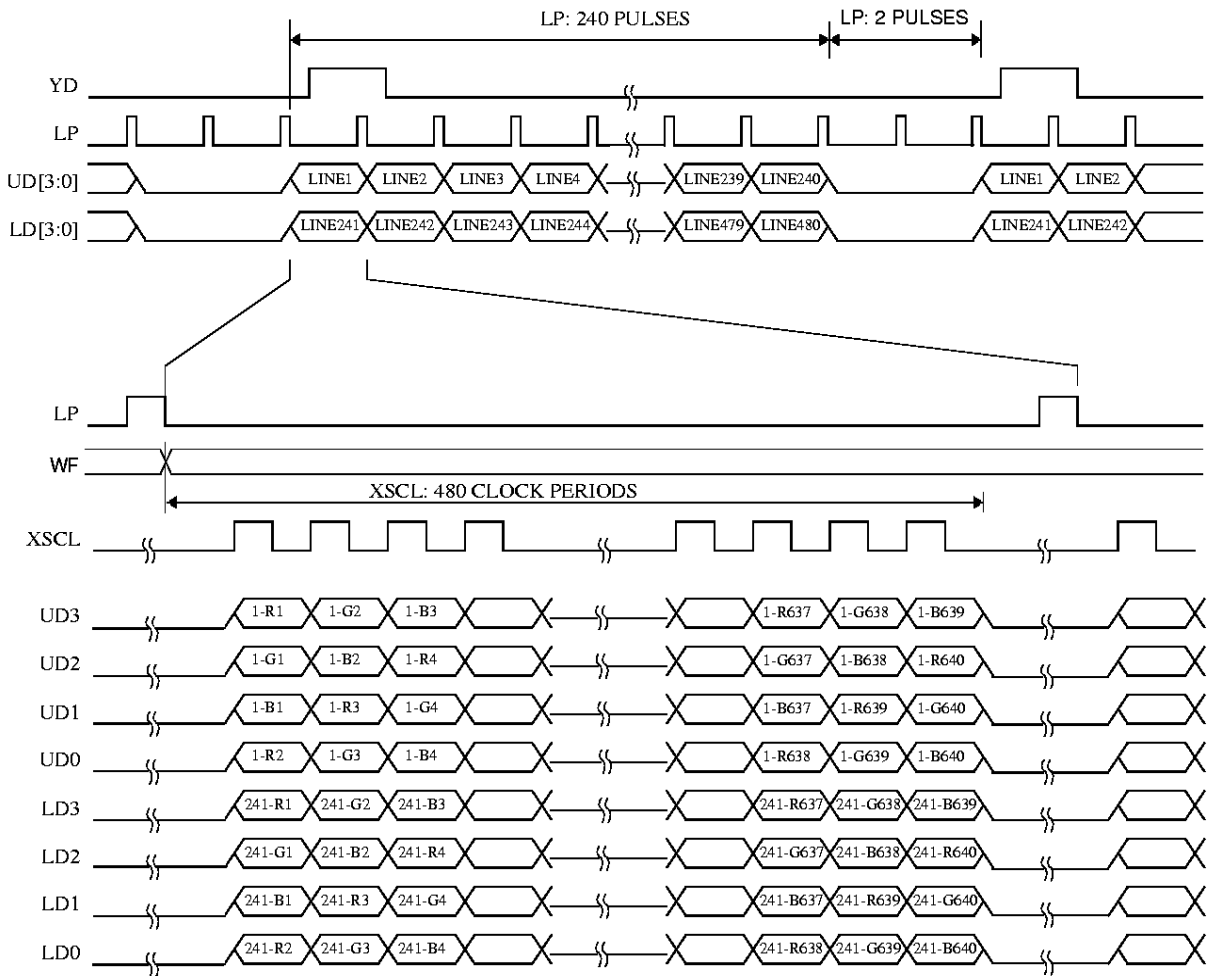

Example timing for a 640x480 panel

### ■ COLOR PASSIVE STN LCD PANEL INTERFACE

#### 16-Bit Single Panel With External Circuit

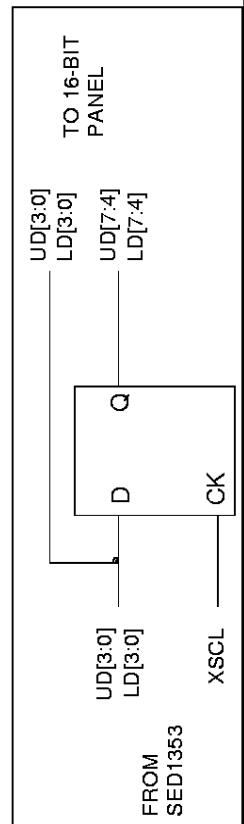
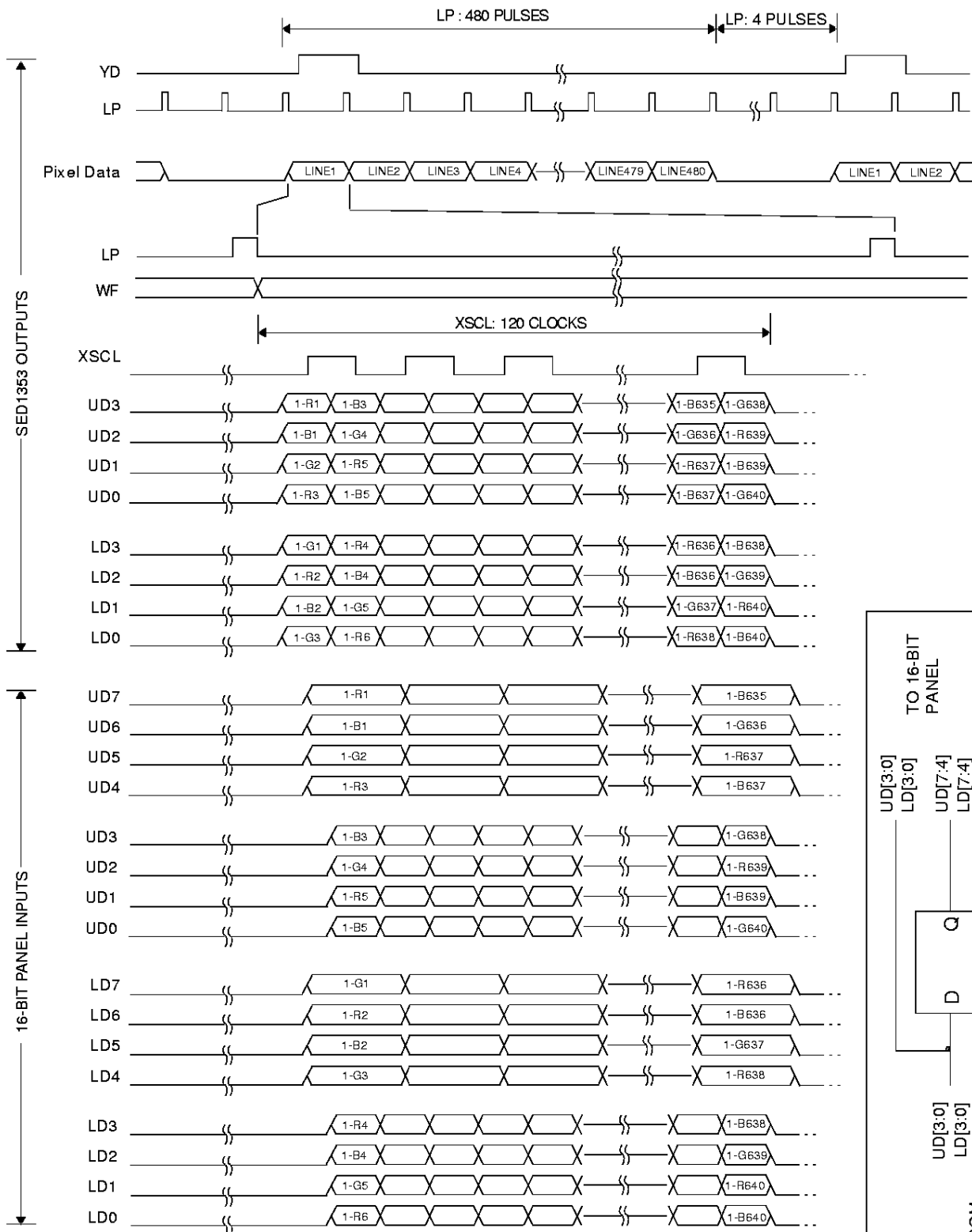



**■ COLOR PASSIVE STN LCD PANEL INTERFACE**

**16-Bit Dual Panel With External Circuit**

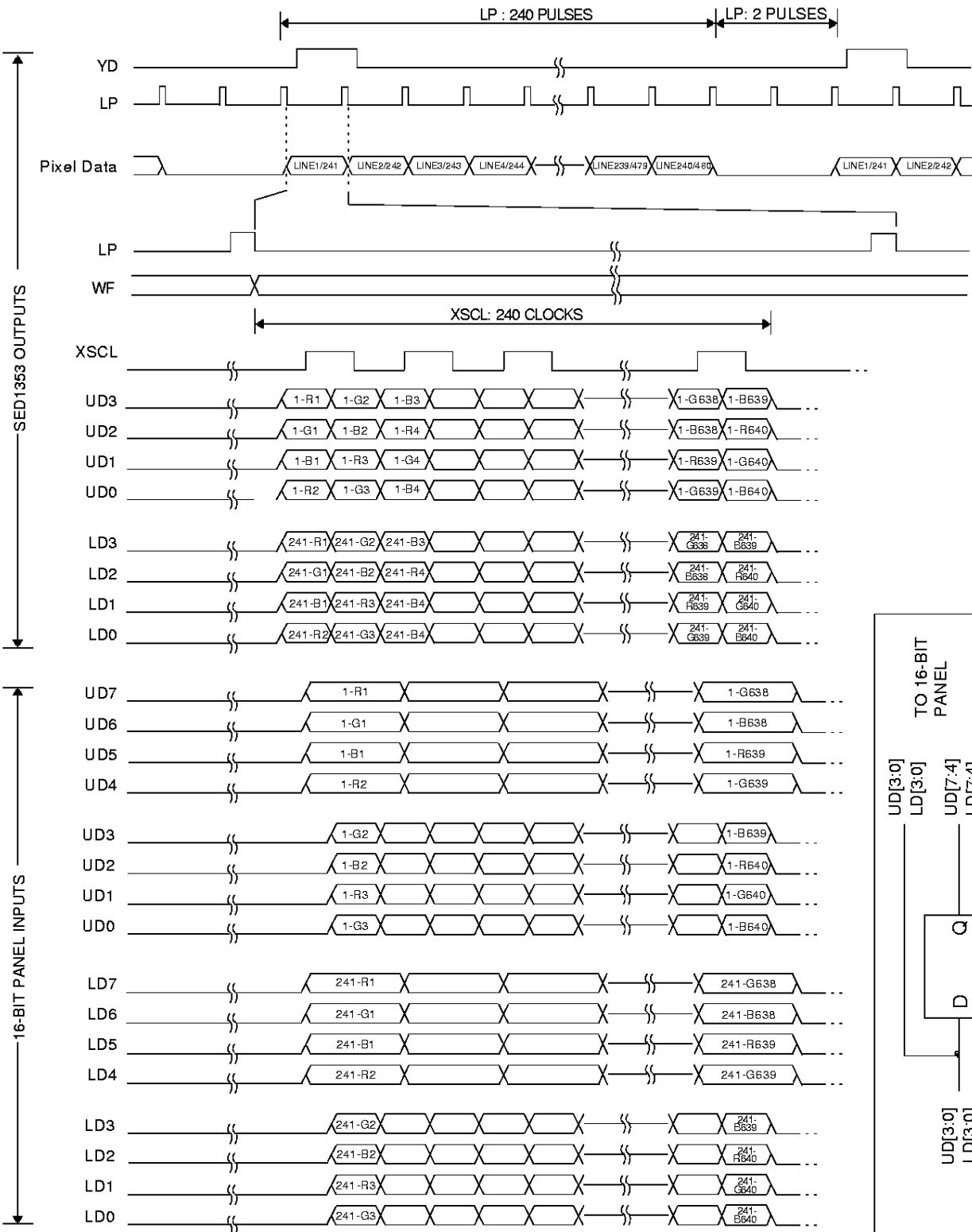

Example timing for a 640x480 panel

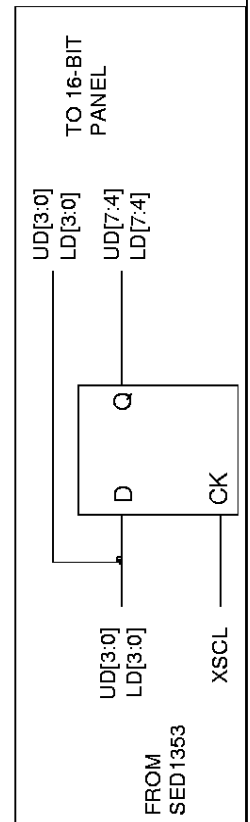

**SED1353**

■ PACKAGE DIMENSIONS: SED1353F0A

QFP5-100PIN-S2  
(SED1353F0A)

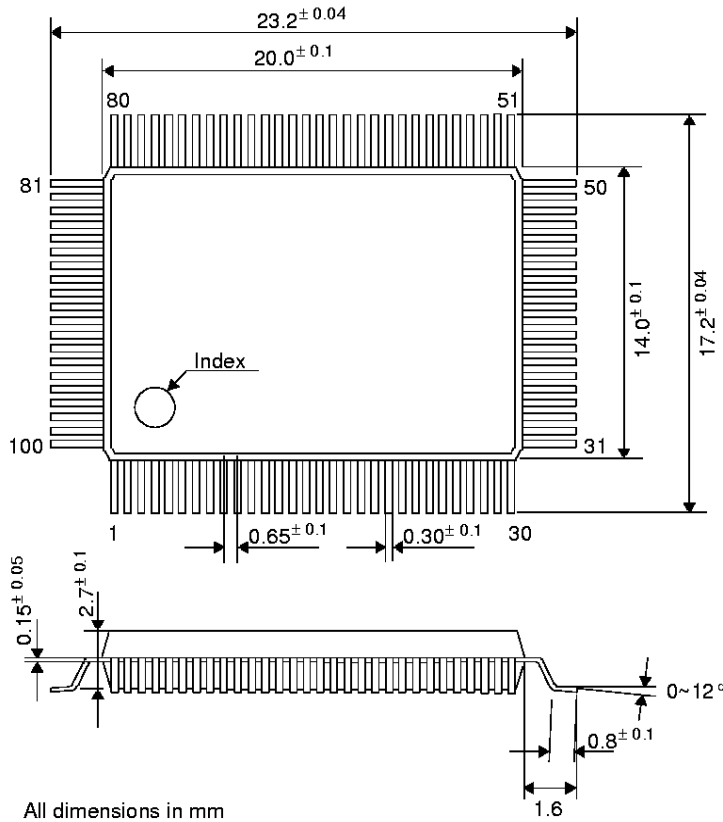

All dimensions in mm

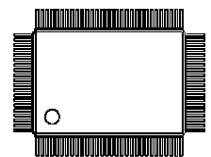

Actual Size

■ **PACKAGE DIMENSIONS: SED1353F1A**

**QFP15-100PIN-STD**  
**(SED1353F1A)**

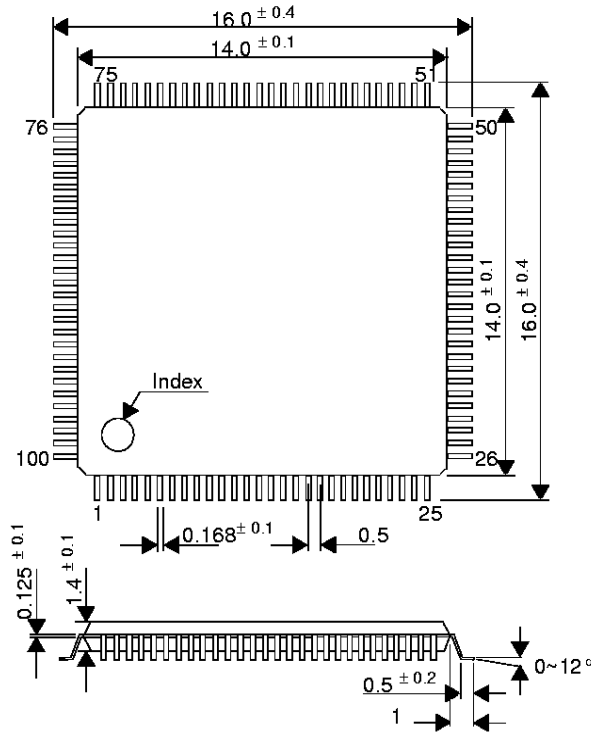

All dimensions in mm

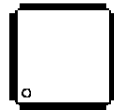

Actual Size

**■ COMPREHENSIVE SUPPORT TOOLS**

SEIKO EPSON provides to the designer and manufacturer a complete set of resources and tools for the development of LCD Graphics Systems.

**Evaluation/Demonstration Board**

- Assembled and fully tested Graphics Evaluation board
- Schematic of Evaluation/Demo board
- Parts List
- Installation Guide
- OEM Utilities
- User Utilities
- Evaluation Software

**Documentation**

- Technical manuals
- Evaluation/demo board manual

CONTACT YOUR LOCAL SALES REPRESENTATIVE FOR THESE COMPREHENSIVE DESIGN TOOLS:

- SED1353 TECHNICAL MANUAL
- SDU1353B0C EVALUATION BOARD

**Head Office**

S-MOS Systems Inc.  
150 River Oaks Parkway  
San Jose, CA 95134  
Tel: (408) 922-0200  
Fax: (408) 922-0238  
<http://www.smos.com>

**North Central USA**

1450 East American Lane  
Suite 1550  
Schaumburg, Illinois 60173  
Tel: (847) 517-7667  
Fax: (847) 517-7601  
Cell: (847) 558-6662  
Pager: (888) 789-3471

**Eastern USA**

301 Edgewater Place  
Suite 120  
Wakefield, MA 01880  
Tel: (781) 246-3600  
Fax: (781) 246-5443

**Southeast USA**

4300 Six Forks Rd.  
Suite 430  
Raleigh, NC 27609  
Tel: (919) 781-7667  
Fax: (919) 781-6778

S-MOS assumes no responsibility or liability for (1) any errors or inaccuracies contained in the information herein and (2) the use of the information or a portion thereof in any application, including any claim for (a) copyright or patent infringement or (b) direct, indirect, special or consequential damages. There are no warranties extended or granted by this document. The information herein is subject to change without notice from S-MOS.

January 1998

© Copyright 1997, 1998 S-MOS Systems, Inc.



## **SED1353 Dot Matrix Graphics Color LCD Controller**

# **Hardware Functional Specification**

**Drawing Office No. X18A-A-001-03**

Copyright © 1997 S-MOS Systems Inc. All rights reserved.

This document, and any text derived, extracted or transmitted from it, is the sole property of S-MOS Systems Inc. and may not be used, copied, transmitted or otherwise made available to any other person, unless specifically allowed under license agreement with S-MOS Systems Inc. If furnished under a license, this document may be used and copied only in accordance with the terms of such license, and with the inclusion of this copyright notice. No title or ownership of the technology herein is transferred.

The information in this document is subject to change without notice and should not be construed as a commitment by S-MOS Systems Inc. This document does not necessarily describe any current planned or future product by S-MOS Systems Inc., nor does it represent any commitment to implement any such product.

**THIS PAGE LEFT BLANK**

## Table of Contents

<b>1</b>	<b>INTRODUCTION</b>	<b>9</b>
1.1	Scope	9
1.2	Overview Description	9
<b>2</b>	<b>FEATURES</b>	<b>10</b>
2.1	Technology	10
2.2	System	10
2.3	Display Modes	10
2.4	Display Support	11
2.5	Power Management	11
<b>3</b>	<b>TYPICAL SYSTEM BLOCK DIAGRAMS</b>	<b>12</b>
3.1	16-Bit MC68000 MPU	12
3.2	MPU with READY (or WAIT#) signal	13
3.3	ISA Bus	14
3.4	Internal Block Diagram	15
3.5	Functional Block Descriptions	15
3.5.1	Bus Signal Translation	15
3.5.2	Control Registers	15
3.5.3	Sequence Controller	15
3.5.4	LCD Panel Interface	15
3.5.5	Look-Up Table	16
3.5.6	Port Decoder	16
3.5.7	Memory Decoder	16
3.5.8	Data Bus Conversion	16
3.5.9	Address Generator	16
3.5.10	MPU / CRT Selector	16
3.5.11	Display Data Formatter	16
3.5.12	Clock Inputs / Timing	16
3.5.13	SRAM Interface	16
<b>4</b>	<b>PINOUT DIAGRAM</b>	<b>17</b>
<b>5</b>	<b>PIN DESCRIPTION</b>	<b>22</b>
5.1	Description	22
5.2	Summary of Configuration Options	26
<b>6</b>	<b>D.C. CHARACTERISTICS</b>	<b>27</b>
<b>7</b>	<b>A.C. CHARACTERISTICS</b>	<b>29</b>
7.1	Bus Interface Timing	29
7.1.1	MC68000 Interface Timing	29
7.1.2	Non-MC68000, MPU/Bus With READY (or WAIT#) Signal	33
7.2	Clock Input Requirements	37
7.2.1	Recommended Clock Input	38

7.3	Display Memory Interface Timing . . . . .	39
7.3.1	Write Data to Display Memory . . . . .	39
7.3.2	Read Data From Display Memory . . . . .	40
7.4	LCD Interface . . . . .	41
7.4.1	LCD Interface Timing - 4-Bit Single, 8-Bit Single/Dual Monochrome Panels . . . . .	41
7.4.2	LCD Interface Timing - 4-Bit Single Color Panel . . . . .	44
7.4.3	LCD Interface Timing - 8-Bit Single Color Panels Format 2/8-Bit Dual Color Panels . . . . .	46
7.4.4	LCD Interface Timing - 16-Bit Single/Dual Color Panels . . . . .	48
7.4.5	LCD Interface Timing - 8-Bit Single Color Panels Format 1 . . . . .	50
7.4.6	LCD Interface Options . . . . .	52
<b>8</b>	<b>HARDWARE REGISTER INTERFACE . . . . .</b>	<b>.61</b>
8.1	Register Descriptions . . . . .	61
8.2	Look-Up Table Architecture . . . . .	72
8.2.1	Gray Shade Display Modes . . . . .	72
8.2.2	Color Display Modes . . . . .	74
8.3	Power Save Modes . . . . .	77
8.3.1	Power Save Mode 1 . . . . .	77
8.3.2	Power Save Mode 2 . . . . .	77
8.3.3	Power Save Mode Function Summary . . . . .	78
8.3.4	Pin States in Power Save Modes . . . . .	78
<b>9</b>	<b>DISPLAY MEMORY INTERFACE . . . . .</b>	<b>.79</b>
9.1	SRAM Configurations Supported . . . . .	79
9.1.1	8-Bit Mode . . . . .	79
9.1.2	16-Bit Mode . . . . .	81
9.2	SRAM Access Time . . . . .	83
9.2.1	8-Bit Display Memory Interface: . . . . .	83
9.2.2	16-Bit Display Memory Interface: . . . . .	83
9.3	Frame Rate Calculation . . . . .	84
9.3.1	For single panel . . . . .	84
9.3.2	For dual panel . . . . .	84
9.4	Memory Size Calculation . . . . .	85
9.5	Memory Size Requirement . . . . .	85
<b>10</b>	<b>MECHANICAL DATA . . . . .</b>	<b>.87</b>



## List of Tables

Table 4-1:	PAD Coordinates . . . . .	20
Table 5-1:	Bus Interface . . . . .	22
Table 5-2:	Display Memory Interface . . . . .	24
Table 5-3:	LCD Interface . . . . .	25
Table 5-4:	Clock Inputs . . . . .	25
Table 5-5:	Power Supply . . . . .	25
Table 5-6:	Summary of Power On / Reset Options . . . . .	26
Table 5-7:	I/O and Memory Addressing Example . . . . .	26
Table 6-1:	Absolute Maximum Ratings . . . . .	27
Table 6-2:	Recommended Operating Conditions . . . . .	27
Table 6-3:	Input Specifications . . . . .	27
Table 6-4:	Output Specifications . . . . .	28
Table 7-1:	IOW# Timing (MC68000) . . . . .	29
Table 7-2:	IOR# Timing (MC68000) . . . . .	30
Table 7-3:	MEMW# Timing (MC68000) . . . . .	31
Table 7-4:	MEMR# Timing (MC68000) . . . . .	32
Table 7-5:	IOW# Timing (Non-MC68000) . . . . .	33
Table 7-6:	IOR# Timing (Non-MC68000) . . . . .	34
Table 7-7:	MEMW# Timing (Non-MC68000) . . . . .	35
Table 7-8:	MEMR# Timing (Non-MC68000) . . . . .	36
Table 7-9:	Clock Input Requirements . . . . .	37
Table 7-10:	Write Data to Display Memory . . . . .	39
Table 7-11:	Read Data From Display Memory . . . . .	40
Table 7-12:	LCD Interface Timing - 4-Bit Single and 8-Bit Single/Dual Monochrome Panel . . . . .	42
Table 7-13:	LCD Interface Timing - 4-Bit Single Color Panel. . . . .	45
Table 7-14:	LCD Interface Timing - 8-Bit Single Color Panels Format 2/8-Bit Dual Color Panels . . . . .	47
Table 7-15:	LCD Interface Timing - 16-Bit Single/Dual Color Panels . . . . .	49
Table 7-16:	LCD Interface Timing - 8-Bit Single Color Panels Format 1 . . . . .	51
Table 8-1:	Gray Shade/Color Mode Selection . . . . .	62
Table 8-2:	LCD Data Width . . . . .	63
Table 8-3:	Maximum Value of Line Byte Count Register - 8-Bit Display Memory Interface . . . . .	64
Table 8-4:	Maximum Value of Line Byte Count Register - 16-Bit Display Memory Interface . . . . .	64
Table 8-5:	Power Save Mode Selection . . . . .	64
Table 8-6:	ID Bit Usage . . . . .	70
Table 8-7:	Look-Up Table Access . . . . .	70
Table 8-8:	Look-Up Table Configurations . . . . .	72
Table 8-9:	Power Save Mode Selection . . . . .	77
Table 8-10:	Power Save Mode Function Summary . . . . .	78
Table 8-11:	Pin States in Power Save Modes. . . . .	78
Table 9-1:	8-Bit Display Memory Interface SRAM Access Time . . . . .	83
Table 9-2:	16-Bit Display Memory Interface SRAM Access Time. . . . .	83
Table 9-3:	Memory Size Requirement: Number of Horizontal Pixels = 640 . . . . .	85
Table 9-4:	Memory Size Requirement: Number of Horizontal Pixels = 480 . . . . .	86
Table 9-5:	Memory Size Requirement: Number of Horizontal Pixels = 320 . . . . .	86

**THIS PAGE LEFT BLANK**

## List of Figures

Figure 1:	16-Bit 68000 Series . . . . .	12
Figure 2:	8-Bit Mode, Example: Z80 . . . . .	13
Figure 3:	16-Bit Mode, Example: i8086 . . . . .	13
Figure 4:	8-Bit Mode (ISA) . . . . .	14
Figure 5:	16-Bit mode (ISA) . . . . .	14
Figure 6:	Internal Block Diagram . . . . .	15
Figure 7:	SED1353F0A Pinout Diagram . . . . .	17
Figure 8:	SED1353F1A Pinout Diagram . . . . .	18
Figure 9:	SED1353D0A Pad Diagram . . . . .	19
Figure 10:	IOW# Timing (MC68000) . . . . .	29
Figure 11:	IOR# Timing (MC68000) . . . . .	30
Figure 12:	MEMW# Timing (MC68000) . . . . .	31
Figure 13:	MEMR# Timing (MC68000) . . . . .	32
Figure 14:	IOW# Timing (Non-MC68000) . . . . .	33
Figure 15:	IOR# Timing (Non-MC68000) . . . . .	34
Figure 16:	MEMW# Timing (Non-MC68000) . . . . .	35
Figure 17:	MEMR# Timing (Non-MC68000) . . . . .	36
Figure 18:	Clock Input Requirements . . . . .	37
Figure 19:	Recommended Clock Interface . . . . .	38
Figure 20:	Write Data to Display Memory . . . . .	39
Figure 21:	Read Data From Display Memory . . . . .	40
Figure 22:	LCD Interface Timing - Monochrome Panel . . . . .	41
Figure 23:	LCD Interface Timing - 4-Bit Single Color Panel . . . . .	44
Figure 24:	LCD Interface Timing - 8-Bit Single Color Panels Format 2/8-Bit Dual Color Panels . . . . .	46
Figure 25:	LCD Interface Timing - 16-Bit Single/Dual Color Panels . . . . .	48
Figure 26:	LCD Interface Timing - 8-Bit Single Color Panels Format 1 . . . . .	50
Figure 27:	4-Bit Single Monochrome Panel Timing . . . . .	52
Figure 28:	8-Bit Single Monochrome Panel Timing . . . . .	53
Figure 29:	8-Bit Dual Monochrome Panel Timing . . . . .	54
Figure 30:	4-Bit Single Color Panel Timing . . . . .	55
Figure 31:	8-Bit Single Color Panel Timing - Format 1 : AUX[03] Bit 3 = 0 and AUX[01] Bit 2 = 1 . . . . .	56
Figure 32:	8-Bit Single Color Panel Timing - Format 2 : AUX[03] Bit 3 = 1 and AUX[01] Bit 2 = 1 . . . . .	57
Figure 33:	8-Bit Dual Color Panel Timing . . . . .	58
Figure 34:	External Circuit Required for 16-Bit Panel . . . . .	58
Figure 35:	16-Bit Single Color Panel Timing with External Circuit . . . . .	59
Figure 36:	16-Bit Dual Color Panel Timing with External Circuit . . . . .	60

---

Figure 37:	4-Level Gray-Shade Mode Look-Up Table Architecture . . . . .	72
Figure 38:	16-Level Gray-Shade Mode Look-Up Table Architecture. . . . .	73
Figure 39:	4-Level Color Mode Look-Up Table Architecture. . . . .	74
Figure 40:	16-Level Color Mode Look-Up Table Architecture . . . . .	75
Figure 41:	256-Level Color Mode Look-Up Table Architecture . . . . .	76
Figure 42:	8-Bit Mode - 8K bytes SRAM . . . . .	79
Figure 43:	8-Bit Mode - 16K bytes SRAM . . . . .	79
Figure 44:	8-Bit Mode - 32K bytes SRAM . . . . .	80
Figure 45:	8-Bit Mode - 40K bytes SRAM . . . . .	80
Figure 46:	8-Bit Mode - 64K bytes SRAM . . . . .	81
Figure 47:	16-Bit Mode - 16K bytes SRAM. . . . .	81
Figure 48:	16-Bit Mode - 64K bytes SRAM. . . . .	82
Figure 49:	16-Bit Mode - 128K bytes SRAM . . . . .	82
Figure 50:	Mechanical Drawing QFP5-100-S2 (SED 1353F0A) . . . . .	87
Figure 51:	Mechanical Drawing QFP15-100-STD (SED1353F1A). . . . .	88

---

# 1 INTRODUCTION

## 1.1 Scope

This is the Functional Specification for the SED1353 Dot Matrix Graphic Color LCD Controller. Included in this document are timing diagrams, AC and DC characteristics, register descriptions, and power management descriptions. This document is intended for two audiences, Video Subsystem Designers and Software Developers.

## 1.2 Overview Description

This device is designed for products where low cost, low power consumption, and low component count are the major design considerations. This chip operates from 2.7 Volts to 5.5 Volts and up to 25MHz to suit different power consumption, speed and cost requirements. The SED1353 offers a flexible microprocessor interface, and is pin compatible with the SED1352 within the same package types (e.g. the 1353D0A is pin compatible with the 1352D0B; the 1353D1A is pin compatible with the 1352D1B).

The SED1353 is capable of displaying a maximum of 16 levels of gray shade or 256 simultaneous colors. In gray shade modes, a 16x4 Look-Up Table is provided to allow remapping of the 16 possible gray shades displayed on the LCD panel. In color modes, three 16x4 Look-Up Tables are provided to allow remapping of the 4096 possible colors displayed on the LCD panel. The SED1353 can interface to an MC68000 family microprocessor or an 8/16-bit MPU/Bus with minimum external "glue" logic. This device can directly control up to 128K bytes of static RAM with a 16-bit data path, or up to 64K bytes with an 8-bit data path.

## 2 FEATURES

### 2.1 Technology

- low power CMOS
- 2.7 to 5.5 volt operation
- 100 pin QFP5-S2 surface mount package
- 100 pin QFP15-STD surface mount package

### 2.2 System

- maximum 25 MHz input clock (or pixel clock)
- 2-terminal crystal input for internal oscillator or direct connection to external clock source
- maximum 16 MHz, 16-bit MC68000 MPU interface
- 8-bit or 16-bit MPU/Bus interface with memory accesses controlled by a READY (or WAIT#) signal
- option to use built-in index register or direct-mapping to access one of sixteen internal registers
- 8-bit or 16-bit SRAM data bus interface configurations
- display memory configurations :
  - 128k bytes using one 64Kx16 SRAM
  - 128k bytes using two 64Kx8 SRAMs
  - 64k bytes using two 32Kx8 SRAMs
  - 40k bytes using one 8Kx8 and one 32Kx8 SRAM
  - 32k bytes using one 32Kx8 SRAM
  - 16k bytes using two 8Kx8 SRAMs
  - 8k bytes using one 8Kx8 SRAM

### 2.3 Display Modes

- 1 bit-per-pixel, black-and-white display mode
- 2/4 bits-per-pixel, 4/16 level gray shade display modes
- 2/4/8 bits-per-pixel, 4/16/256 level color display modes
- one 16x4 Look-Up Table provided for gray shade display modes
- three 16x4 Look-Up Tables provided for color display modes
- maximum 16 shades of gray
- maximum 256 simultaneous colors from a possible 4096 colors
- split screen display mode (see AUX[0A])
- virtual display mode (see AUX[0D])

#### Note

256 color display mode support requires a 16-bit display memory interface

## 2.4 Display Support

- example resolutions:
  - 1024 x 768 black-and-white
  - 640 x 480 with 4 colors/grays
  - 640 x 400 with 16 colors/grays
  - 320 x 240 with 256 colors
- passive monochrome LCD panels:
  - 4-bit single (4-bit data transfer)
  - 8-bit single (8-bit data transfer)
  - 8-bit dual (4-bit data transfer for each half panel)
- passive color LCD panels:
  - 4-bit single (4-bit data transfer)
  - 8-bit single (8-bit data transfer)
  - 8-bit dual (4-bit data transfer for each half panel)
  - 16-bit single (8-bit data transfer with external circuit)
  - 16-bit dual (8-bit data transfer with external circuit)

See Section 9.5 on page 85 for complete details

## 2.5 Power Management

- two software power-save modes
- low power consumption
- panel power control switch (see AUX[01] bit 4)

### 3 TYPICAL SYSTEM BLOCK DIAGRAMS

The following figures show typical system implementations of the SED1353. All of the following block diagrams are shown without SRAM or LCD display. Refer to the interface specific Application Notes for complete details.

#### 3.1 16-Bit MC68000 MPU

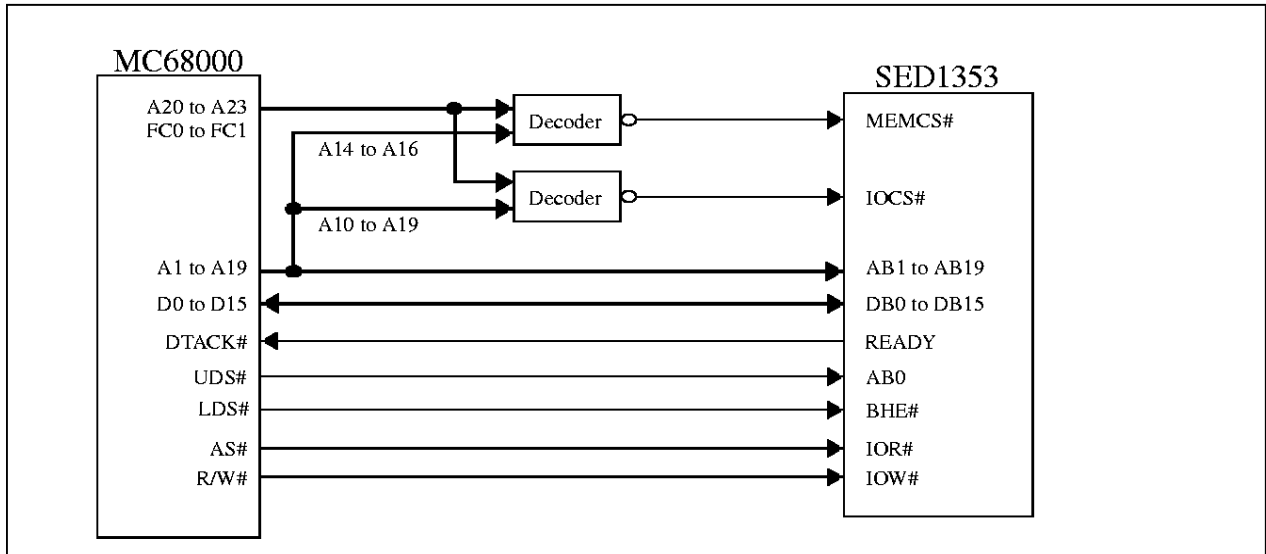

Figure 1: 16-Bit 68000 Series  
(example implementation only - actual may vary)



### 3.2 MPU with READY (or WAIT#) signal

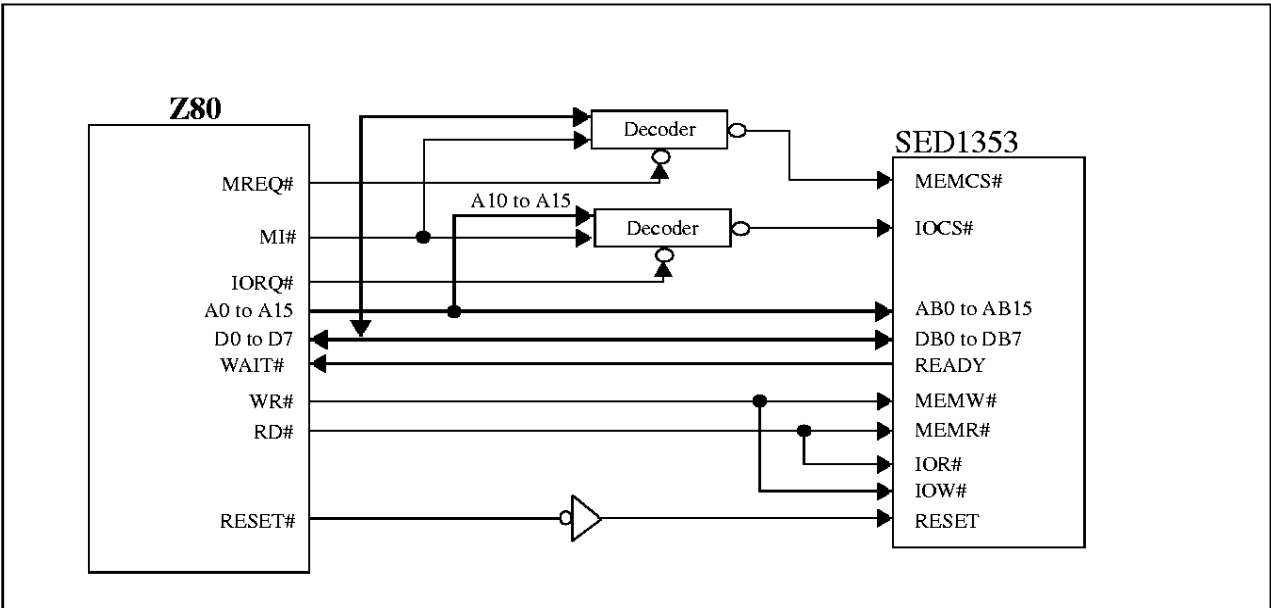

Figure 2: 8-Bit Mode, Example: Z80  
 (example implementation only - actual may vary)

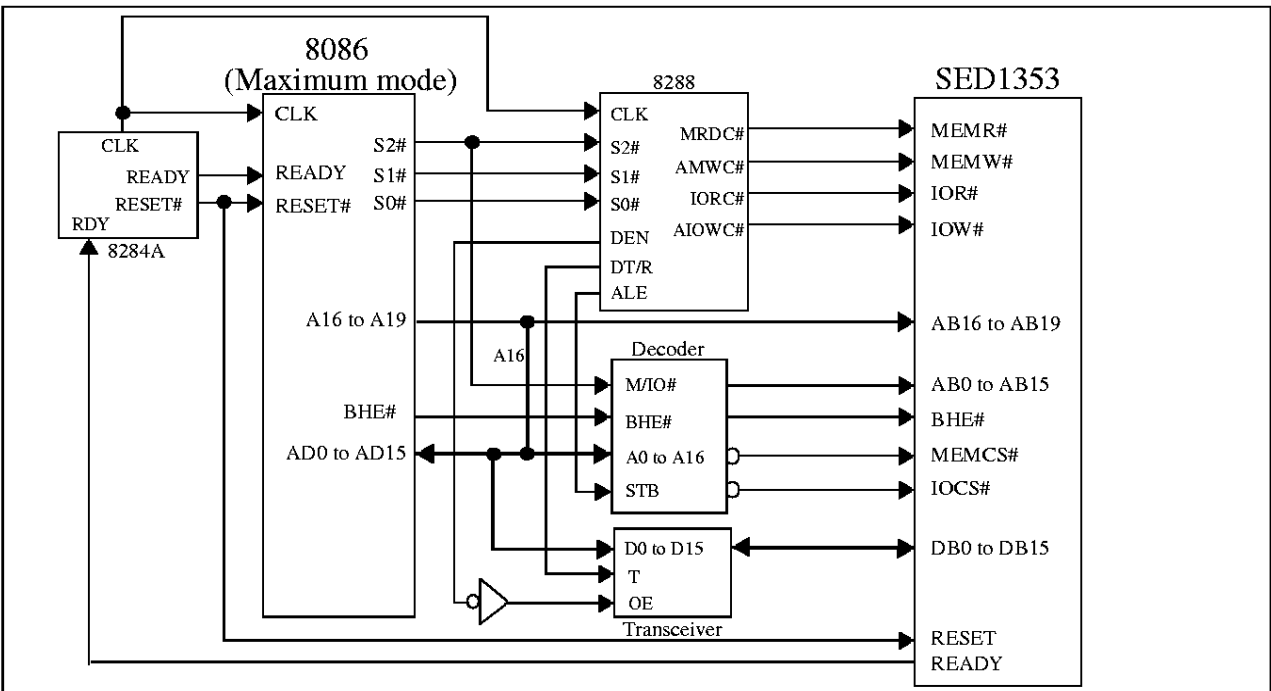

Figure 3: 16-Bit Mode, Example: i8086 (maximum mode)  
 (example implementation only - actual may vary)

### 3.3 ISA Bus

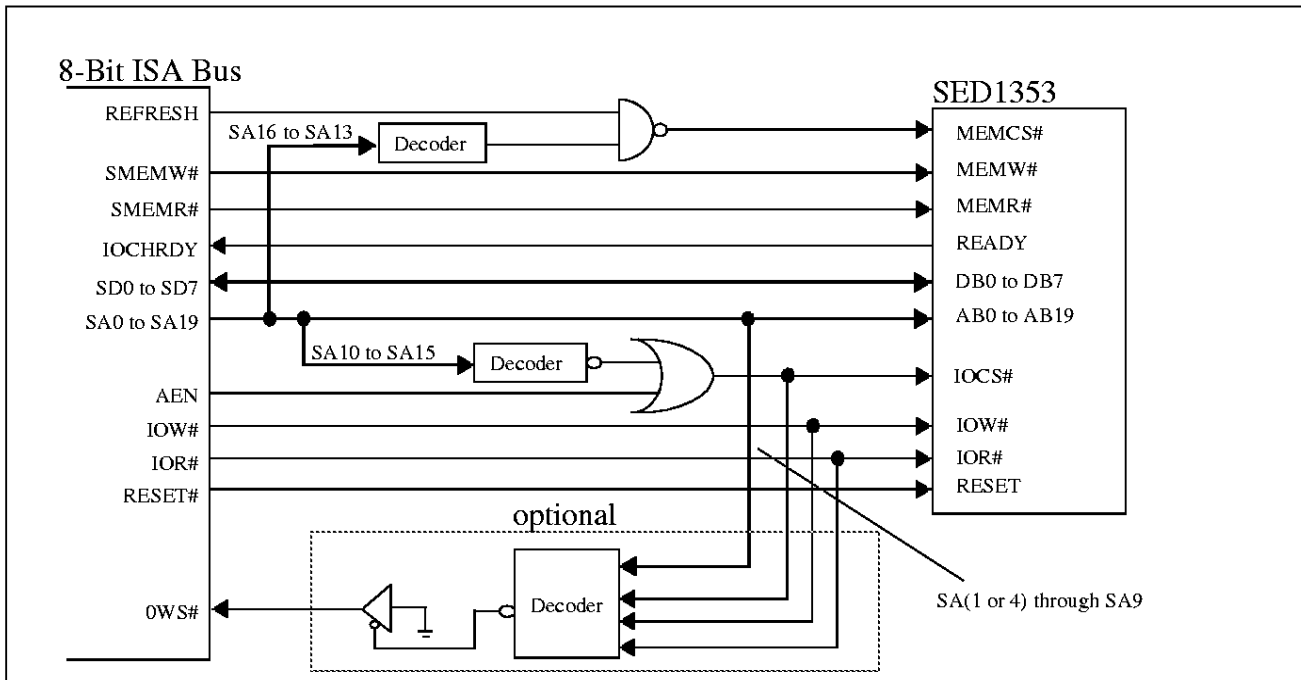

Figure 4: 8-Bit Mode (ISA)  
(example implementation only - actual may vary)

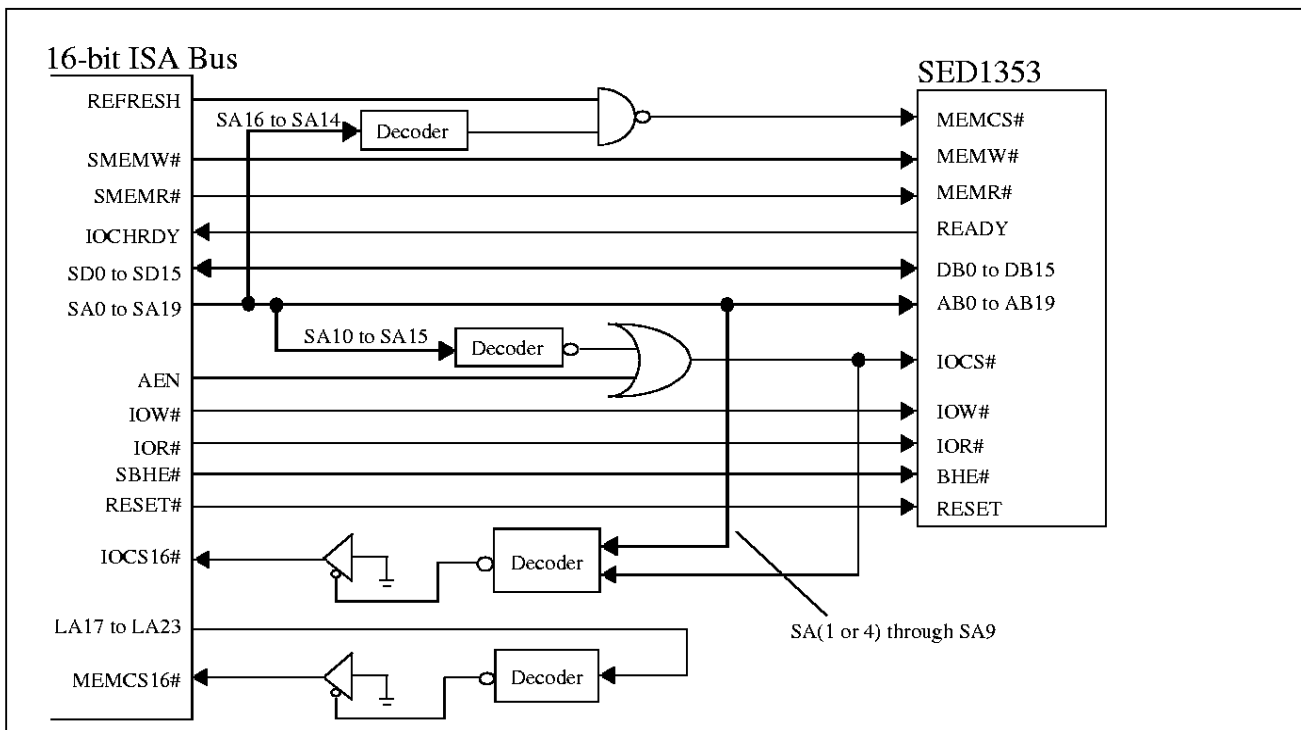

Figure 5: 16-Bit mode (ISA)  
(example implementation only - actual may vary)

### 3.4 Internal Block Diagram

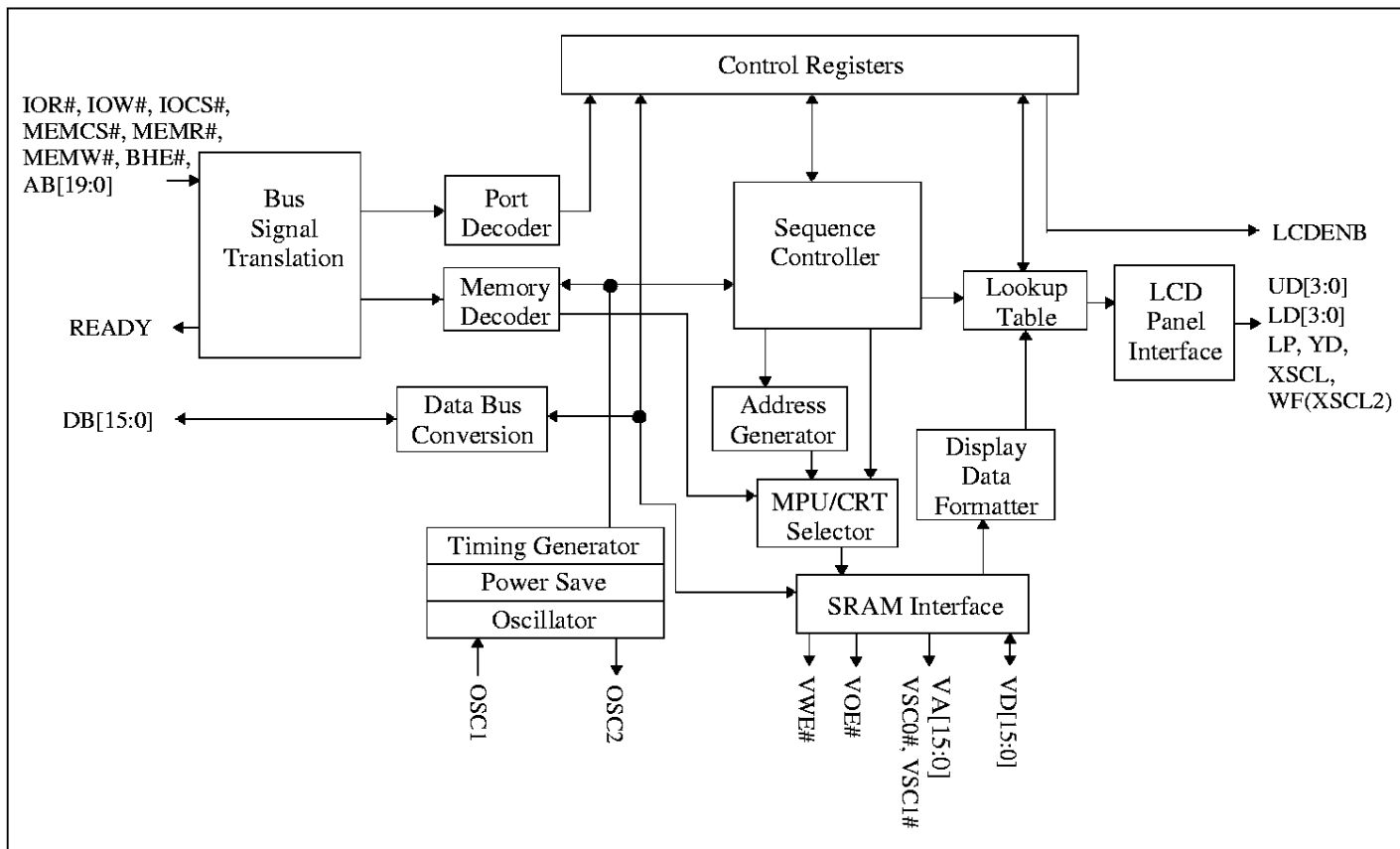

Figure 6: Internal Block Diagram

### 3.5 Functional Block Descriptions

#### 3.5.1 Bus Signal Translation

According to configuration setting VD2, Bus Signal Translation translates MC68000 type MPU signals, or READY type MPU signals to internal bus interface signals.

#### 3.5.2 Control Registers

The Control Register contains 16 internal control and configuration registers. These registers can be accessed by either direct-mapping or by using the built-in internal index register.

#### 3.5.3 Sequence Controller

The Sequence Controller generates horizontal and vertical display timings according to the configuration registers settings.

#### 3.5.4 LCD Panel Interface

The LCD Panel Interface performs frame rate modulation and output data pattern formatting for both passive monochrome and passive color LCD panels.

### 3.5.5 Look-Up Table

The Look-Up Table contains three 16x4-bit wide palettes. In gray shade modes, the “green” palette can be configured for the re-mapping of 16 possible shades of gray. In color modes, all three palettes can be configured for the re-mapping of 4096 possible colors.

### 3.5.6 Port Decoder

According to configuration settings VD1, VD12 - VD4, IOCS# and address lines AB9-1, the Port Decoder validates a given I/O cycle.

### 3.5.7 Memory Decoder

According to configuration settings VD15 - VD13, MEMCS# and address lines AB19-17, the Memory Decoder validates a given memory cycle.

### 3.5.8 Data Bus Conversion

According to configuration setting VD0, Data Bus Conversion maps the external data bus, either 8-bit or 16-bit, into the internal odd and even data bus.

### 3.5.9 Address Generator

The Address Generator generates display refresh addresses to be used to access display memory.

### 3.5.10 MPU / CRT Selector

The MPU / CRT Selector grants access to the display memory from either the MPU or the display refresh circuitry.

### 3.5.11 Display Data Formatter

The Display Data Formatter reads in the display data from the display memory and outputs the correct format for all supported gray shade and color selections.

### 3.5.12 Clock Inputs / Timing

Clock Inputs / Timing generates the internal master clock according to gray-level / color selected and display memory interface. The master clock (MCLK) can be:

- MCLK = input clock
- MCLK = 1/2 input clock
- MCLK = 1/4 input clock.

Pixel clock = input clock =  $f_{OSC}$ .

### 3.5.13 SRAM Interface

The SRAM Interface generates the necessary signals to interface to the Display Memory (SRAM).

## 4 PINOUT DIAGRAM

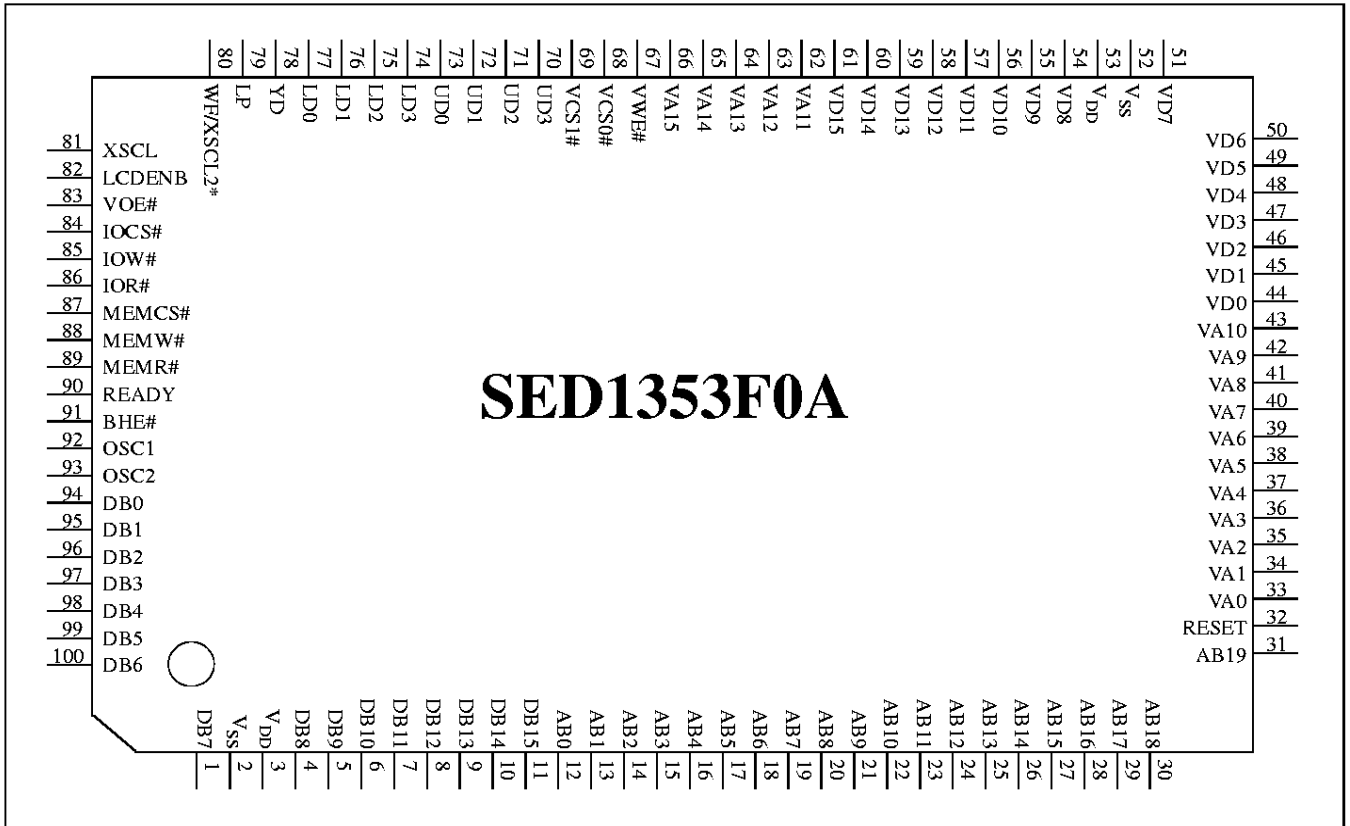

Figure 7: SED1353F0A Pinout Diagram

Package type: 100 pin surface mount QFP5-S2.

**Note**

- \* Pin 80 = WF in all display modes except format 1 for 8-bit single color panel.
- \* Pin 80 = XSCL2 in format 1 for 8-bit single color panel.

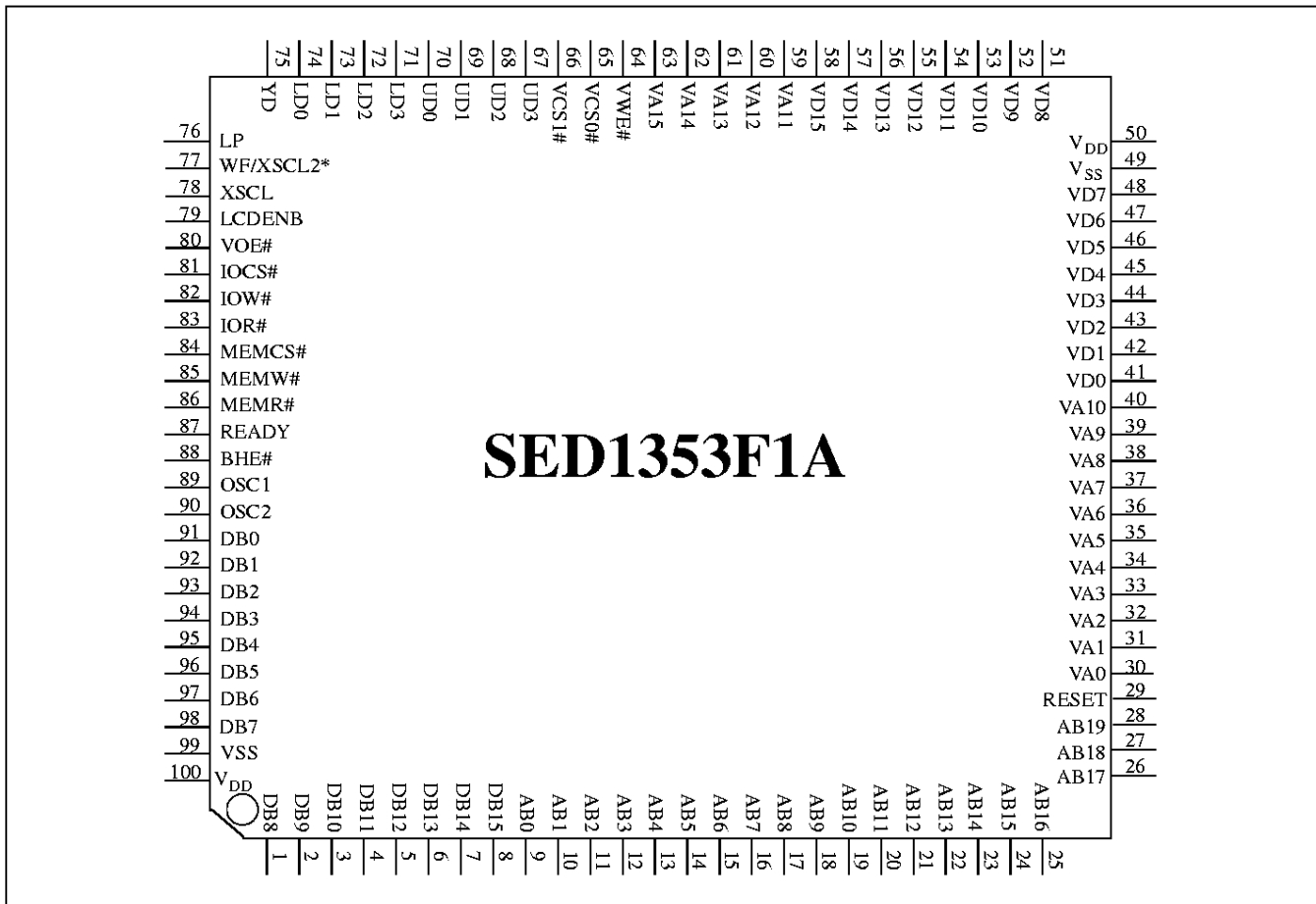

Figure 8: SED1353F1A Pinout Diagram

Package type: 100 pin surface mount QFP15-STD.

**Note**

\* Pin 77 = WF in all display modes except format 1 for 8-bit single color panel.

\* Pin 77 = XSCL2 in format 1 for 8-bit single color panel.

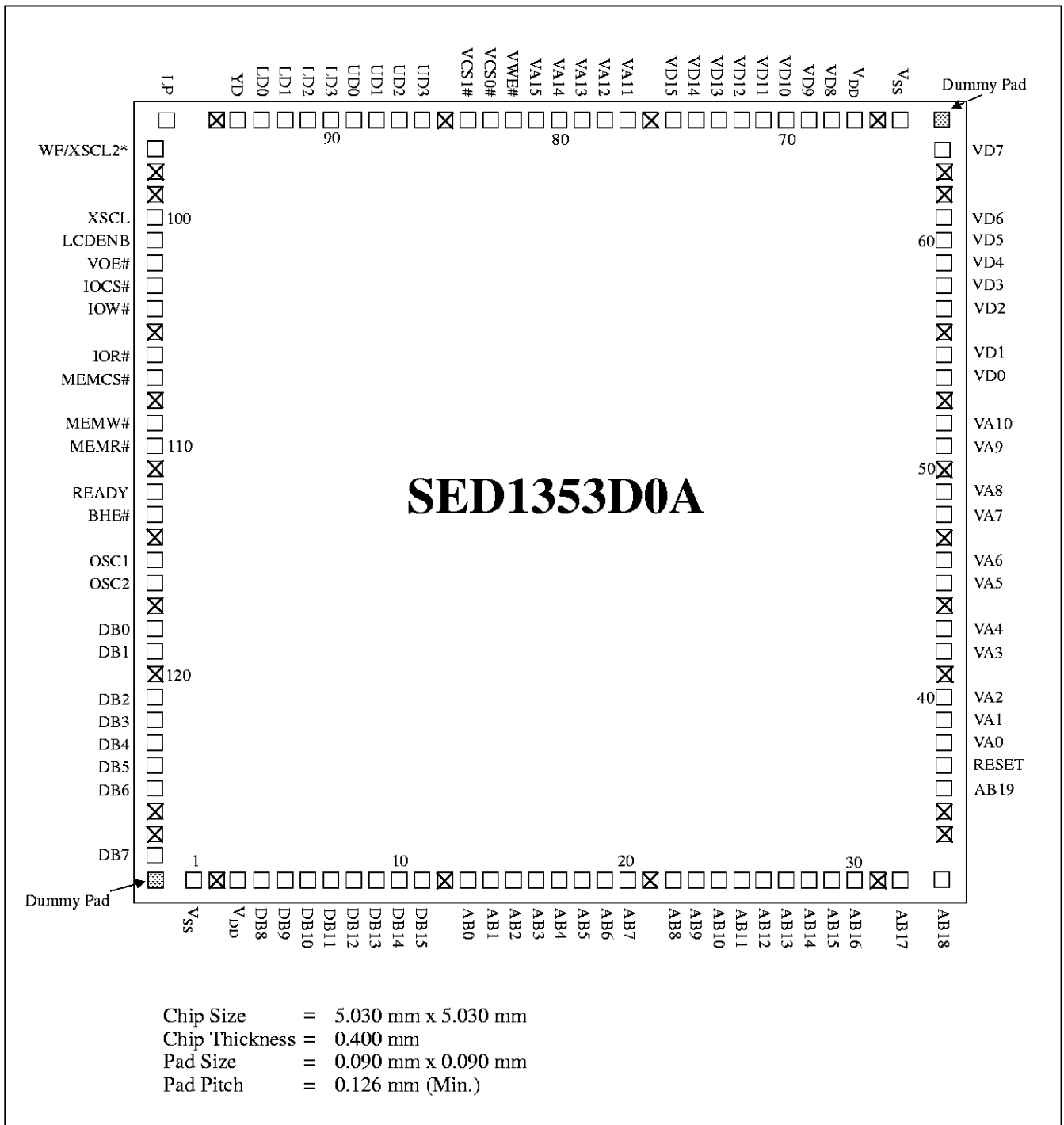

Figure 9: SED1353D0A Pad Diagram

**Note**

- \* Pad 97 = WF in all display modes except format 1 for 8-bit single color panel.
- \* Pad 97 = XSCL2 in format 1 for 8-bit single color panel.

Table 4-1: PAD Coordinates

Pad No.	Pin Name	Pad Center Coordinate		Pad No.	Pin Name	Pad Center Coordinate	
		X	Y			X	Y
1	VSS	-2.165	-2.390	37	RESET	2.390	-1.535
2	---	-2.000	-2.390	38	VA0	2.390	-1.388
3	VDD	-1.840	-2.390	39	VA1	2.390	-1.246
4	DB8	-1.685	-2.390	40	VA2	2.390	-1.106
5	DB9	-1.535	-2.390	41	---	2.390	-0.969
6	DB10	-1.388	-2.390	42	VA3	2.390	-0.835
7	DB11	-1.246	-2.390	43	VA4	2.390	-0.703
8	DB12	-1.106	-2.390	44	---	2.390	-0.573
9	DB13	-0.969	-2.390	45	VA5	2.390	-0.444
10	DB14	-0.835	-2.390	46	VA6	2.390	-0.317
11	DB15	-0.703	-2.390	47	---	2.390	-0.190
12	---	-0.573	-2.390	48	VA7	2.390	-0.063
13	AB0	-0.444	-2.390	49	VA8	2.390	0.063
14	AB1	-0.317	-2.390	50	---	2.390	0.190
15	AB2	-0.190	-2.390	51	VA9	2.390	0.317
16	AB3	-0.063	-2.390	52	VA10	2.390	0.444
17	AB4	0.063	-2.390	53	---	2.390	0.573
18	AB5	0.190	-2.390	54	VD0	2.390	0.703
19	AB6	0.317	-2.390	55	VD1	2.390	0.835
20	AB7	0.444	-2.390	56	---	2.390	0.969
21	---	0.573	-2.390	57	VD2	2.390	1.106
22	AB8	0.703	-2.390	58	VD3	2.390	1.246
23	AB9	0.835	-2.390	59	VD4	2.390	1.388
24	AB10	0.969	-2.390	60	VD5	2.390	1.535
25	AB11	1.106	-2.390	61	VD6	2.390	1.685
26	AB12	1.246	-2.390	62	---	2.390	1.840
27	AB13	1.388	-2.390	63	---	2.390	2.000
28	AB14	1.535	-2.390	64	VD7	2.390	2.165
29	AB15	1.685	-2.390	65	VSS	2.165	2.390
30	AB16	1.840	-2.390	66	---	2.000	2.390
31	---	2.000	-2.390	67	VDD	1.840	2.390
32	AB17	2.165	-2.390	68	VD8	1.685	2.390
33	AB18	2.390	-2.340	69	VD9	1.535	2.390
34	---	2.390	-2.000	70	VD10	1.388	2.390
35	---	2.390	-1.840	71	VD11	1.246	2.390
36	AB19	2.390	-1.685	72	VD12	1.106	2.390



Table 4-1: PAD Coordinates

Pad No.	Pin Name	Pad Center Coordinate		Pad No.	Pin Name	Pad Center Coordinate	
		X	Y			X	Y
73	VD13	0.969	2.390	102	VOE#	-2.390	1.388
74	VD14	0.835	2.390	103	IOCS#	-2.390	1.246
75	VD15	0.703	2.390	104	IOW#	-2.390	1.106
76	---	0.573	2.390	105	---	-2.390	0.969
77	VA11	0.444	2.390	106	IOR#	-2.390	0.835
78	VA12	0.317	2.390	107	MEMCS#	-2.390	0.703
79	VA13	0.190	2.390	108	---	-2.390	0.573
80	VA14	0.063	2.390	109	MEMW#	-2.390	0.444
81	VA15	-0.063	2.390	110	MEMR#	-2.390	0.317
82	VWE#	-0.190	2.390	111	---	-2.390	0.190
83	VCS0#	-0.317	2.390	112	READY	-2.390	0.063
84	VCS1#	-0.444	2.390	113	BHE#	-2.390	-0.063
85	---	-0.573	2.390	114	---	-2.390	-0.190
86	UD3	-0.703	2.390	115	OSC1	-2.390	-0.317
87	UD2	-0.835	2.390	116	OSC2	-2.390	-0.444
88	UD1	-0.969	2.390	117	---	-2.390	-0.573
89	UD0	-1.106	2.390	118	DB0	-2.390	-0.703
90	LD3	-1.246	2.390	119	DB1	-2.390	-0.835
91	LD2	-1.388	2.390	120	---	-2.390	-0.969
92	LD1	-1.535	2.390	121	DB2	-2.390	-1.106
93	LD0	-1.685	2.390	122	DB3	-2.390	-1.246
94	YD	-1.840	2.390	123	DB4	-2.390	-1.388
95	---	-2.000	2.390	124	DB5	-2.390	-1.535
96	LP	-2.340	2.390	125	DB6	-2.390	-1.685
97	WF/XSCL2	-2.390	2.165	126	---	-2.390	-1.840
98	---	-2.390	2.000	127	---	-2.390	-2.000
99	---	-2.390	1.840	128	DB7	-2.390	-2.165
100	XSCL	-2.390	1.685	129	Dummy Pad	2.390	2.390
101	LCDENB	-2.390	1.535	130	Dummy Pad	-2.390	-2.390

## 5 PIN DESCRIPTION

### 5.1 Description

**Key:**

- I = Input
- O = Output
- I/O = Bidirectional (Input/Output)
- P = Power pin
- COx = CMOS level output driver, x denotes driver type (see Table 6-4, "Output Specifications," on page 28)
- COxS = CMOS level output driver with slew rate control for noise reduction, x denotes driver type (see Table 6-4, "Output Specifications," on page 28)
- TSx = Tri-state CMOS level output driver, x denotes driver type (see Table 6-4, "Output Specifications," on page 28)
- TSxD2 = Tri-state CMOS level output driver with pull down resistor (typical values of 100K $\Omega$ /200K $\Omega$  at 5V/3.0V respectively), x denotes driver type (see Table 6-4, "Output Specifications," on page 28)
- TTL = TTL level input ( $V_{DD} = 5.0V$ , see Table 6-3, "Input Specifications," on page 27)
- TTLS = TTL level input with hysteresis

*Table 5-1: Bus Interface*

Pin Name	Type	F0A Pin #	F1A Pin #	D0A Pad #	Driver	Description
DB0-DB15	I/O	94 - 100, 1, 4 - 11	91 - 98, 1 - 8	118-119, 121-125, 128, 4-11	TS2	These pins are connected to the system data bus. In 8-bit bus mode, DB8-DB15 must be tied to $V_{DD}$ .
AB0	I	12	9	13	TTLS	In MC68000 MPU interface, this pin is connected to the Upper Data Strobe (UDS#) pin of MC68000. In other MPU/Bus interfaces, this pin is connected to the system address bus.
AB1-AB19	I	13 - 31	10 - 28	14-20, 22-30, 32-33, 36	TTL	These pins are connected to the system address bus.
BHE#	I	91	88	113	TTLS	In MC68000 MPU interface, this pin is connected to the Lower Data Strobe (LDS#) pin of MC68000. In other MPU/Bus interfaces, this pin is the Byte High Enable input for use with 16-bit system. In 8-bit bus mode tie the BHE# input to $V_{DD}$ .
IOCS#	I	84	81	103	TTLS	Active low input to select one of sixteen internal registers.

Table 5-1: Bus Interface

Pin Name	Type	F0A Pin #	F1A Pin #	D0A Pad #	Driver	Description
IOW#	I	85	82	104	TTLS	In MC68000 MPU interface, this pin is connected to the R/W# pin of MC68000. This input pin defines whether the data transfer is a read (active high) or write (active low) cycle. In other MPU/Bus interfaces, this is the active low input to write data into an internal register.
IOR#	I	86	83	106	TTLS	In MC68000 MPU interface, this pin is connected to the AS# pin of MC68000. This input pin indicates a valid address is available on the address bus. In other MPU/Bus interfaces, this is the active low input to read data from an internal register.
MEMCS#	I	87	84	107	TTLS	Active low input to indicate a memory cycle.
MEMW#	I	88	85	109	TTLS	Active low input to indicate a memory write cycle. This pin should be tied to V <sub>DD</sub> in an MC68000 MPU interface.
MEMR#	I	89	86	110	TTLS	Active low input to indicate a memory read cycle. This pin should be tied to V <sub>DD</sub> in an MC68000 MPU interface.
READY	O	90	87	112	TS3	For MC68000 MPU interface, this pin is connected to the DTACK# pin of MC68000 and is driven low when the data transfer is complete. In other MPU/Bus interfaces, this output is driven low to force the system to insert wait states when needed.  READY is placed in a high impedance (Hi-Z) state after the transfer is completed.
RESET	I	32	29	37	TTLS	Active high input to force all signals to their inactive states.

Table 5-2: Display Memory Interface

Pin Name	Type	F0A Pin #	F1A Pin #	D0A Pad #	Driver	Description
VD0-VD15	I/O	44 - 51, 54 - 61	41 - 48, 51 - 58	54-55, 57-61, 64, 68-75	TS1D2	<p>These pins are connected to the display memory data bus. For 16-bit interface, VD0-VD7 are connected to the display memory data bus of even byte addresses and VD8-VD15 are connected to the display memory data bus of odd byte addresses. The output drivers of these pins are placed in a high impedance state when RESET is high.</p> <p>On the falling edge of RESET, the values of VD0-VD15 are latched into the chip to configure various hardware options (see Section Table 5-6: on page 26).</p> <p>VD0-VD15 each have an internal pull-down resistor (see Section Table 6-3: on page 27).</p>
VA0-VA15	O	33 - 43, 62 - 66	30 - 40 59 - 63	38-40, 42-43, 45-46, 48-49, 51-52, 77-81	CO1	These pins are connected to the display memory address bus.
VCS1#	O	69	66	84	CO1	Active low chip-select output to the second or odd byte address SRAM. See Display Memory Interface section for details.
VCS0#	O	68	65	83	CO1	Active low chip-select output to the first or even byte address SRAM. See Display Memory Interface section for details.
VWE#	O	67	64	82	CO1	Active low output used for writing data to the display memory. This pin is connected to the WE# input of the SRAMs.
VOE#	O	83	80	102	CO1	Active low output to enable reading of data from the display memory. This pin is connected to the OE# input of the SRAMs.

Table 5-3: LCD Interface

Pin Name	FPDI-1™ Pin Name <sup>a</sup>	Type	F0A Pin #	F1A Pin #	D0A Pad #	Driver	Description
UD3-UD0 LD3-LD0	UD3-UD0 UD3-LD0	O	70 - 73 74 - 77	67 - 70 71 - 74	86 - 89 90 - 93	CO3S	Panel display data bus. The data format depends on the specific panel connected. For 4-bit single panels, LD3-LD0 are driven low (0 state).
XSCL	FPSHIFT	O	81	78	100	CO3	Display data shift clock. Data is shifted into the LCD X-drivers on the falling edge of this signal.
LP	FPLINE	O	79	76	96	CO3	Display data latch clock. The falling edge of this signal is used to latch a row of display data in the LCD X-drivers and to turn on the Y driver (row driver).
WF/ XSCL2	MOD FPSHIFT2	O	80	77	97	CO3	For format 1 of 8-bit single color panels this is the second shift clock. For all other modes, this is the LCD backplane BIAS signal. This output toggles once every frame, or as programmed in AUX[05] bits 7-2.
YD	FPFRAME	O	78	75	94	CO3	Vertical scanning start pulse. A logic '1' on this signal, sampled by the LCD module on the falling edge of LP, is used by the panel Y driver (row driver) to indicate the start of the vertical frame.
LCDENB	----	O	82	79	101	CO2	LCD enable signal output. It can be used externally to turn off the panel supply voltage and backlight.

<sup>a</sup> VESA Flat Panel Display Interface Standard (FPDI-1™)

Table 5-4: Clock Inputs

Pin Name	Type	F0A Pin #	F1A Pin #	D0A Pad #	Driver	Description
OSC1	I	92	89	115	*	This pin, along with OSC2, is the 2-terminal crystal interface when using a 2-terminal crystal as the clock input. If an external oscillator is used as a clock source, then this pin is the clock input.
OSC2	O	93	90	116	*	This pin, along with OSC1, is the 2-terminal crystal interface when using a 2-terminal crystal as the clock input. If an external oscillator is used as a clock source this pin should be left unconnected.

Table 5-5: Power Supply

Pin Name	Type	F0A Pin #	F1A Pin #	D0A Pad #	Driver	Description
V <sub>DD</sub>	P	3, 53	50, 100	3, 67	P	Voltage supply
V <sub>SS</sub>	P	2, 52	49, 99	1, 65	P	Voltage ground

## 5.2 Summary of Configuration Options

The SED1353 requires some configuration information on power-up. This information is provided through the SRAM data lines VD[0...15]. The state of these pins are read on the falling edge of RESET and used to configure the following options:

Table 5-6: Summary of Power On / Reset Options

Pin Name	value on this pin at falling edge of RESET is used to configure: (1/0)	
	1	0
VD0	16-bit host bus interface	8-bit host bus interface
VD1	Use direct-mapping for I/O accesses	Use internal index register for I/O accesses
VD2	MC68000 MPU interface	MPU / Bus interface with memory accesses controlled by a READY (WAIT#) signal
VD3	Swap of high and low data bytes in 16-bit bus interface	No byte swap of high and low data bytes in 16-bit bus interface
VD12-VD4	Select I/O mapping address bits [9:1].  These nine bits are latched on power-up and are compared to the MPU address bits [9-1]. A valid I/O cycle combined with a valid address will enable the internal I/O decoder. Therefore, both types of I/O mapping are limited to even address boundaries to determine either the absolute or indexed I/O address of the first register. Note that a "valid I/O cycle" includes IOCS# being toggled low.	
VD15-VD13	Select memory mapping address bits [3:1]  These three bits are latched on power-up and are compared to the MPU address bits [19-17]. A valid memory cycle combined with a valid address will enable the internal memory decoder. As only the three most significant bits of the address are compared, the maximum amount of memory supported is 128K bytes. Note that a "valid memory cycle" includes MEMCS# being toggled low.  When using 128K byte memory it must be mapped at an even address such that all 128K bytes is available without a change in state on A17, as this would invalidate the internal compare logic.	

### Note

The SED1353 has internal pulldown resistors on these pins and therefore will be pulled down and read on a logic "0" after RESET. If pullup resistors are required refer to Table 6-3, "Input Specifications," on page 27 for pulldown resistor values.

**Example:** If an ISA bus (no byte swap) with memory segment "A" and I/O location 300h are used, the corresponding settings of VD15-VD0 would be:

Table 5-7: I/O and Memory Addressing Example

Pin Name	8-Bit ISA Bus		16-Bit ISA Bus	
	Index Register	Direct Mapping	Index Register	Direct Mapping
VD0	0	0	1	1
VD1	0	1	0	1
VD2	0	0	0	0
VD3	0	0	0	0
VD12-VD4	11 0000 000	11 0000 xxx	11 0000 000	11 0000 xxx
VD15-VD13	101	101	101	101

Where x = don't care; 1 = connected to pull-up resistor; 0 = no pull-up resistor

## 6 D.C. CHARACTERISTICS

Table 6-1: Absolute Maximum Ratings

Symbol	Parameter	Rating	Units
$V_{DD}$	Supply Voltage	-0.3 to + 6.0	V
$V_{IN}$	Input Voltage	-0.3 to $V_{DD} + 0.5$	V
$V_{OUT}$	Output Voltage	-0.3 to $V_{DD} + 0.5$	V
$T_{STG}$	Storage Temperature	-65 to 150	°C
$T_{SOL}$	Solder Temperature/Time	260 for 10 sec. max at lead	°C

Table 6-2: Recommended Operating Conditions

Symbol	Parameter	Condition	Min	Typ	Max	Units
$V_{DD}$	Supply Voltage	$V_{SS} = 0$ V	2.7	3.0/3.3/5.0	5.5	V
$V_{IN}$	Input Voltage		$V_{SS}$	--	$V_{DD}$	V
$I_{OPR}$	Operating Current	$f_{OSC} = 6$ MHz 256 colors		4.5/5.0/11		mA
$T_{OPR}$	Operating Temperature		-40	25	85	°C
$P_{TYP}$	Typical Active Power Consumption	$f_{OSC} = 6$ MHz 256 colors		13.5/16.5/55		mW

Table 6-3: Input Specifications

Symbol	Parameter	Condition	Min	Typ	Max	Units
$V_{IL}$	Low Level Input Voltage	$V_{DD} = 4.5$ V $V_{DD} = 3.0$ V $V_{DD} = 2.7$ V			0.8 0.4 0.3	V
$V_{IH}$	High Level Input Voltage	$V_{DD} = 5.5$ V $V_{DD} = 3.6$ V $V_{DD} = 3.3$ V	2.0 1.3 1.2			V
$V_{T+}$	Positive-going Threshold	$V_{DD} = 5.0$ $V_{DD} = 3.3$ $V_{DD} = 3.0$			2.4 1.4 1.3	V
$V_{T-}$	Negative-going Threshold	$V_{DD} = 5.0$ $V_{DD} = 3.3$ $V_{DD} = 3.0$	0.6 0.5 0.4			V
$V_H$	Hysteresis Voltage	$V_{DD} = 5.0$ $V_{DD} = 3.3$ $V_{DD} = 3.0$	0.1 0.1 0.1			V
$I_{IZ}$	Input Leakage Current	--	-1		1	µA

Table 6-3: Input Specifications (Continued)

Symbol	Parameter	Condition	Min	Typ	Max	Units
$C_{IN}$	Input Pin Capacitance	$f = 1 \text{ MHz}$ , $V_{DD} = 0V$			12	pF
$R_{PD}$	Pull Down Resistance	$V_{DD} = 5.0V$ $V_I = V_{DD}$	50	100	200	k $\Omega$
$R_{PD}$	Pull Down Resistance	$V_{DD} = 3.3V$ $V_I = V_{DD}$	90	180	360	k $\Omega$
$R_{PD}$	Pull Down Resistance	$V_{DD} = 3.0V$ $V_I = V_{DD}$	100	200	400	k $\Omega$

Table 6-4: Output Specifications

Symbol	Parameter	Condition	Min	Typ	Max	Units
$V_{OL} (5.0V)$	Low Level Output Voltage Type 1 - TS1D2, CO1 Type 2 - TS2, CO2 Type 3 - TS3, CO3, CO3S	$V_{DD} = \text{Min}$ $I_{OL} = 4 \text{ mA}$ $I_{OL} = 8 \text{ mA}$ $I_{OL} = 12 \text{ mA}$			0.4	V
$V_{OL} (3.3V)$	Low Level Output Voltage Type 1 - TS1D2, CO1 Type 2 - TS2, CO2 Type 3 - TS3, CO3, CO3S	$V_{DD} = \text{Min}$ $I_{OL} = 2 \text{ mA}$ $I_{OL} = 4 \text{ mA}$ $I_{OL} = 6 \text{ mA}$			0.3	V
$V_{OL} (3.0V)$	Low Level Output Voltage Type 1 - TS1D2, CO1 Type 2 - TS2, CO2 Type 3 - TS3, CO3, CO3S	$V_{DD} = \text{Min}$ $I_{OL} = 1.8 \text{ mA}$ $I_{OL} = 3.5 \text{ mA}$ $I_{OL} = 5 \text{ mA}$			0.3	V
$V_{OH} (5.0V)$	High Level Output Voltage Type 1 - TS1D2, CO1 Type 2 - TS2, CO2 Type 3 - TS3, CO3, CO3S	$V_{DD} = \text{Min}$ $I_{OH} = -4 \text{ mA}$ $I_{OH} = -8 \text{ mA}$ $I_{OH} = -12 \text{ mA}$	$V_{DD} - 0.4$			V
$V_{OH} (3.3V)$	Low Level Output Voltage Type 1 - TS1D2, CO1 Type 2 - TS2, CO2 Type 3 - TS3, CO3, CO3S	$V_{DD} = \text{Min}$ $I_{OL} = -2 \text{ mA}$ $I_{OL} = -4 \text{ mA}$ $I_{OL} = -6 \text{ mA}$	$V_{DD} - 0.3$			V
$V_{OH} (3.0V)$	High Level Output Voltage Type 1 - TS1D2, CO1 Type 2 - TS2, CO2 Type 3 - TS3, CO3, CO3S	$V_{DD} = \text{Min}$ $I_{OH} = -1.8 \text{ mA}$ $I_{OH} = -3.5 \text{ mA}$ $I_{OH} = -5 \text{ mA}$	$V_{DD} - 0.3$			V
$I_{OZ}$	Output Leakage Current	--	-1		1	$\mu\text{A}$
$C_{OUT}$	Output Pin Capacitance	$f = 1 \text{ MHz}$ , $V_{DD} = 0V$			12	pF
$C_{BID}$	Bidirectional Pin Capacitance	$f = 1 \text{ MHz}$ , $V_{DD} = 0V$			12	pF



## 7 A.C. CHARACTERISTICS

Conditions :  $V_{DD} = 3.0V \pm 10\%$ ,  $V_{DD} = 3.3V \pm 10\%$ , or  $V_{DD} = 5.0V \pm 10\%$   $T_A = -40\text{ }^\circ\text{C}$  to  $85\text{ }^\circ\text{C}$

$T_{rise}$  and  $T_{fall}$  for all inputs must be  $\leq 5\text{ nsec}$  (10% ~ 90%)

$C_L = 80\text{pF}$  (Bus/MPU Interface)

$C_L = 100\text{pF}$  (LCD Panel Interface)

$C_L = 20\text{pF}$  (Display Memory Interface)

### 7.1 Bus Interface Timing

#### 7.1.1 MC68000 Interface Timing

**Note**

All input timing parameters are based on a maximum 16MHz MPU clock.

**IOW# Timing**

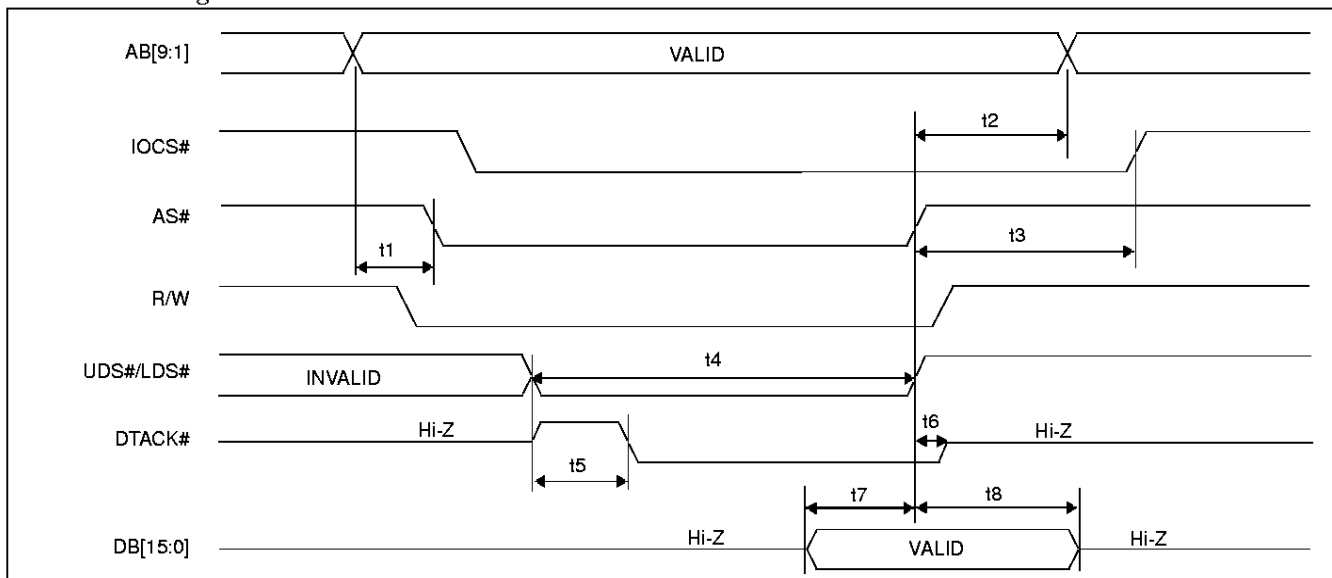

Figure 10: IOW# Timing (MC68000)

Table 7-1: IOW# Timing (MC68000)

Symbol	Parameter	3V/3.3V		5V		Units
		Min	Max	Min	Max	
t1	AB[9:1] valid before AS# falling edge	10		0		ns
t2	AB[9:1] hold from AS# rising edge	20		10		ns
t3	IOCS# hold from AS# rising edge	0		0		ns
t4	UDS#/LDS# valid before AS# rising edge	30		20		ns
t5	UDS#/LDS# falling edge to DTACK# falling edge		40		25	ns
t6	AS# rising edge to DTACK# hi-z delay		40		25	ns
t7	DB[15:0] setup to AS# rising edge	20		10		ns
t8	DB[15:0] hold from AS# rising edge	20		10		ns

## IOR# Timing

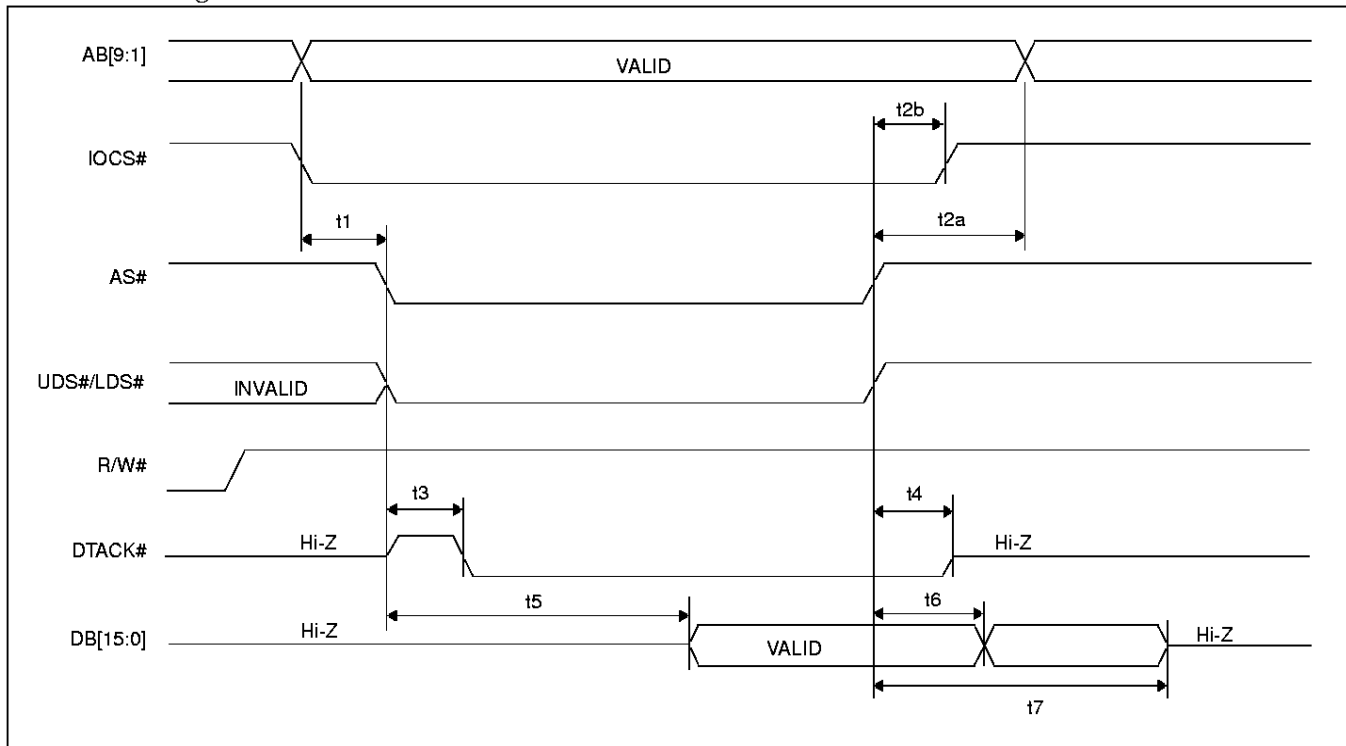

Figure 11: IOR# Timing (MC68000)

Table 7-2: IOR# Timing (MC68000)

Symbol	Parameter	3V/3.3V		5V		Units
		Min	Max	Min	Max	
t1	AB[9:1] and IOCS# valid before AS# falling edge	10		0		ns
t2	AB[9:1] and IOCS# hold from AS# rising edge	20		10		ns
t3	AS# falling edge to DTACK# falling edge		40		25	ns
t4	AS# rising edge to DTACK# hi-z delay		40		25	ns
t5	AS# falling edge to DB[15:0] valid		60		40	ns
t6	DB[15:0] hold from AS# rising edge		20		15	ns
t7	AS# rising edge to DB[15:0] hi-z delay		35		25	ns

**MEMW# Timing**

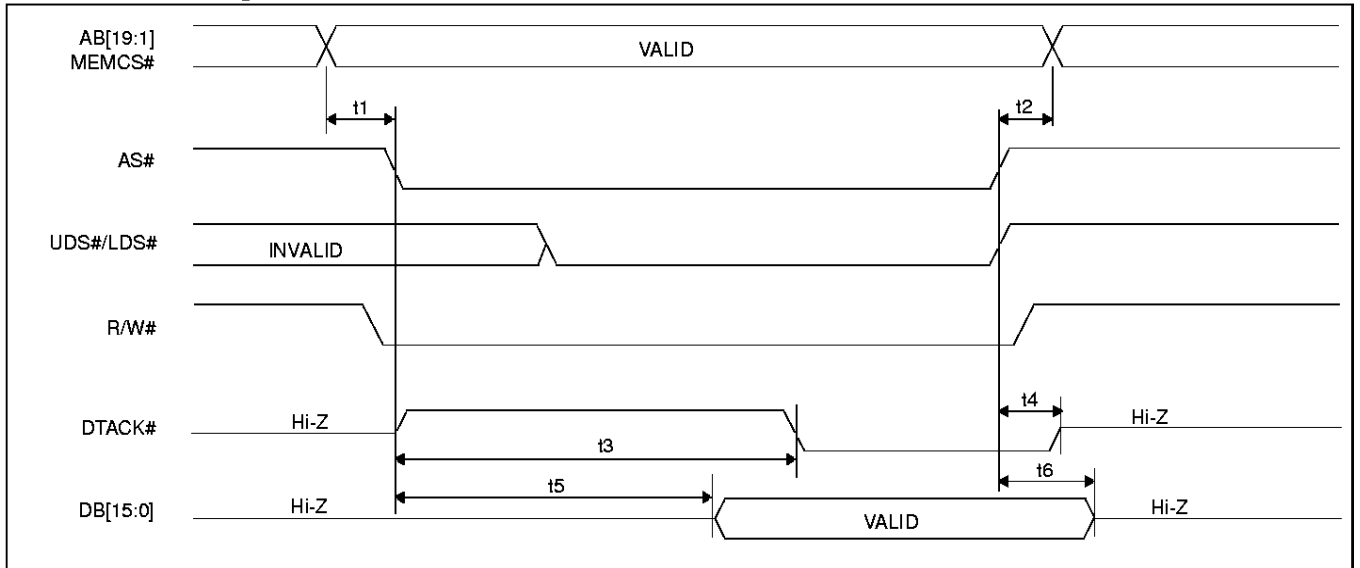

Figure 12: MEMW# Timing (MC68000)

Table 7-3: MEMW# Timing (MC68000)

Symbol	Parameter	3V/3.3V		5V		Units
		Min	Max	Min	Max	
t1	AB[19:1] and MEMCS# valid before AS# falling edge	0		0		ns
t2	AB[19:1] and MEMCS# hold from AS# rising edge	0		0		ns
t3	AS# falling edge to DTACK# falling edge		3.5 * MCLK + 20		3.5 * MCLK + 10	ns
t4	AS# rising edge to DTACK hi-z delay		40		25	ns
t5	AS# falling edge to DB[15:0] valid		MCLK -40		MCLK -20	ns
t6	DB[15:0] hold from AS# rising edge	0		0		ns

Where MCLK =  $1/f_{OSC}$ , or  $2/f_{OSC}$ , or  $4/f_{OSC}$  depending on which display mode the chip is in. (see section 9.2 and 9.3)

**MEMR# Timing**

Figure 13: MEMR# Timing (MC68000)

Table 7-4: MEMR# Timing (MC68000)

Symbol	Parameter	3V/3.3V		5V		Units
		Min	Max	Min	Max	
t1	AB[19:1] and MEMCS# valid before AS# falling edge	0		0		ns
t2	AB[19:1] and MEMCS# hold from AS# rising edge	0		0		ns
t3	AS# falling edge to DTACK# falling edge		3.5 * MCLK + 20		3.5 * MCLK + 10	ns
t4	AS# rising edge to DTACK# hi-z delay		40		15	ns
t5	DTACK# falling edge to DB[15:0] valid		20		15	ns
t6	DB[15:0] hold from AS# rising edge		25		15	ns
t7	AS# rising edge to DB[15:0] hi-z delay		40		30	ns

Where  $MCLK = 1/f_{OSC}$ , or  $2/f_{OSC}$ , or  $4/f_{OSC}$  depending on which display mode the chip is in. (see section 9.2 and 9.3)

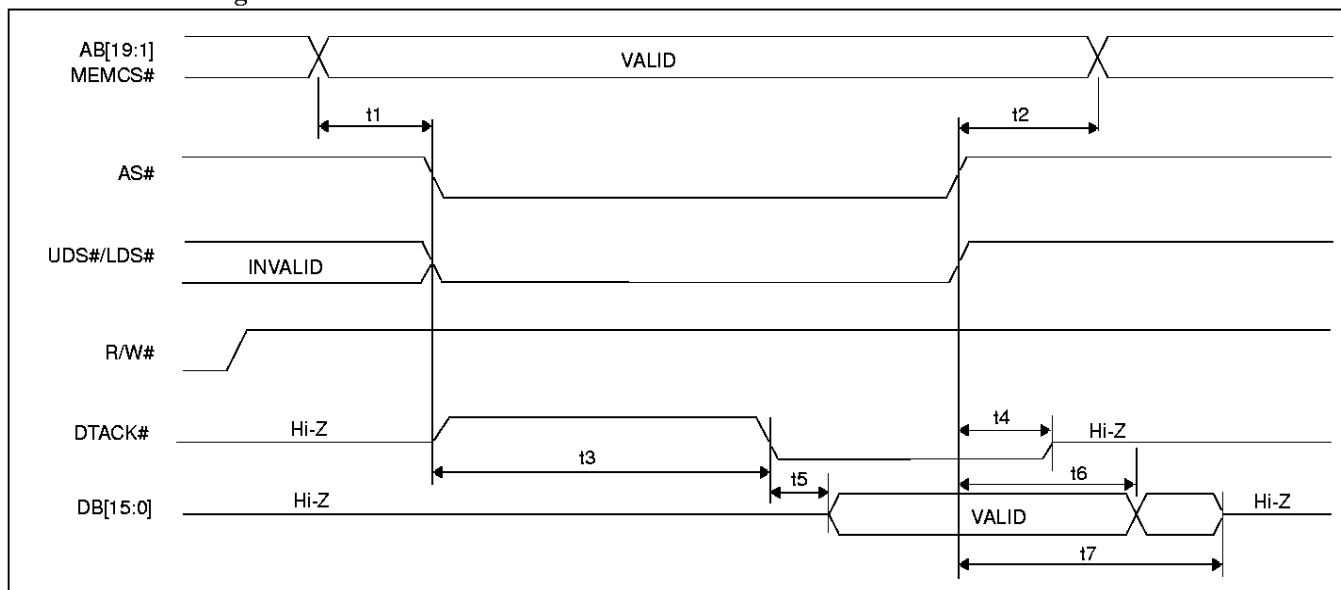
### 7.1.2 Non-MC68000, MPU/Bus With READY (or WAIT#) Signal

#### IOW# Timing

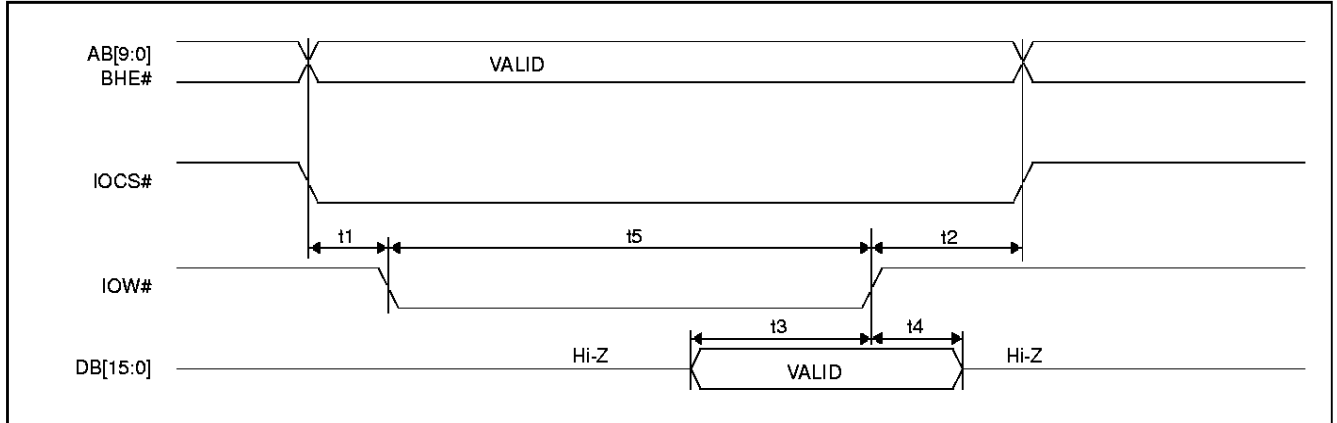

Figure 14: IOW# Timing (Non-MC68000)

Table 7-5: IOW# Timing (Non-MC68000)

Symbol	Parameter	3V/3.3V		5V		Units
		Min	Max	Min	Max	
t1	AB[9:0], BHE# and IOCS# valid before IOW# falling edge	10		0		ns
t2	AB[9:0], BHE# and IOCS# hold from IOW# rising edge	20		10		ns
t3	DB[15:0] setup to IOW# rising edge	20		10		ns
t4	DB[15:0] hold from IOW# rising edge	20		10		ns
t5	Pulse width of IOW#	30		20		ns

**IOR# Timing**

Figure 15: IOR# Timing (Non-MC68000)

Table 7-6: IOR# Timing (Non-MC68000)

Symbol	Parameter	3V/3.3V		5V		Units
		Min	Max	Min	Max	
t1	AB[9:0], BHE# and IOCS# valid before IOR# falling edge	10		0		ns
t2	AB[9:0], BHE# and IOCS# hold from IOR# rising edge	20		10		ns
t3	IOR# falling edge to DB[15:0] valid		60		40	ns
t4	DB[15:0] hold from IOR# rising edge		20		15	ns
t5	IOR# rising edge to DB[15:0] hi-z delay		35		25	ns

**MEMW# Timing**

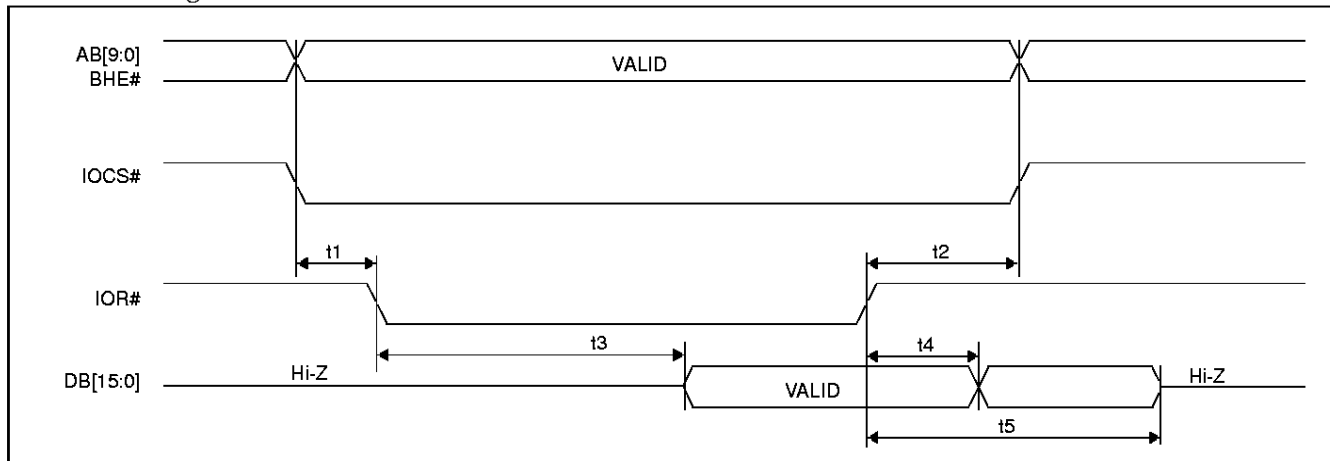
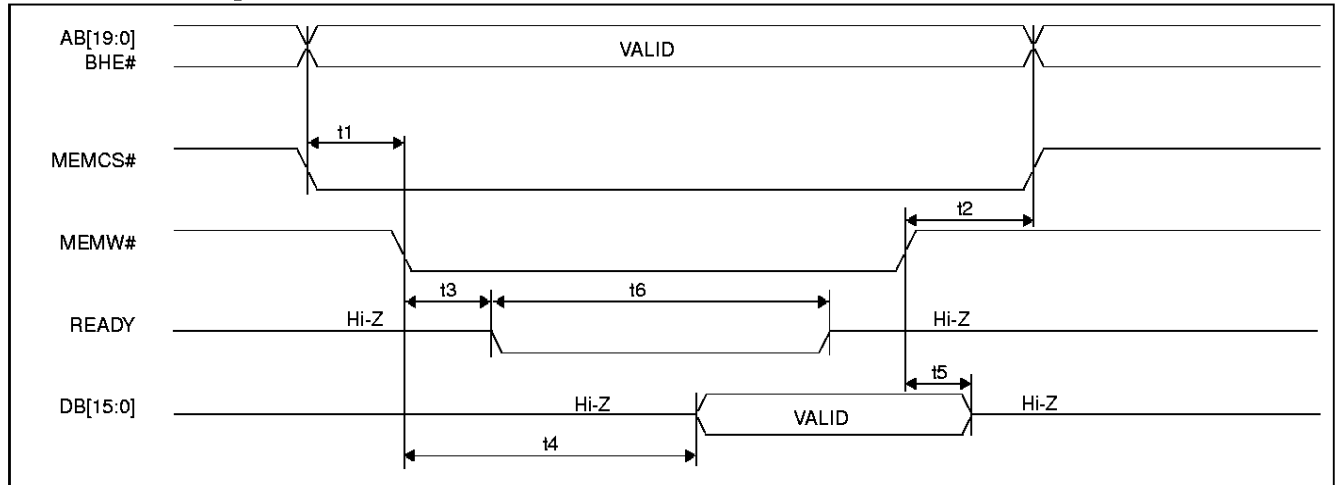

Figure 16: MEMW# Timing (Non-MC68000)

Table 7-7: MEMW# Timing (Non-MC68000)

Symbol	Parameter	3V/3.3V		5V		Units
		Min	Max	Min	Max	
t1	AB[19:0], BHE# and MEMCS# valid before MEMW# falling edge	0		0		ns
t2	AB[19:0], BHE# and MEMCS# hold from MEMW# rising edge	0		0		ns
t3	MEMW# falling edge to READY falling edge		30		20	ns
t4	MEMW# falling edge to DB[15:0] valid		MCLK -40		MCLK -20	ns
t5	DB[15:0] hold from MEMW# rising edge	0		0		ns
t6	READY negated pulse width		3.5* MCLK + 20		3.5* MCLK + 10	ns

Where MCLK =  $1/f_{OSC}$ , or  $2/f_{OSC}$ , or  $4/f_{OSC}$  depending on which display mode the chip is in. (see section 9.2 and 9.3)

**MEMR# Timing**

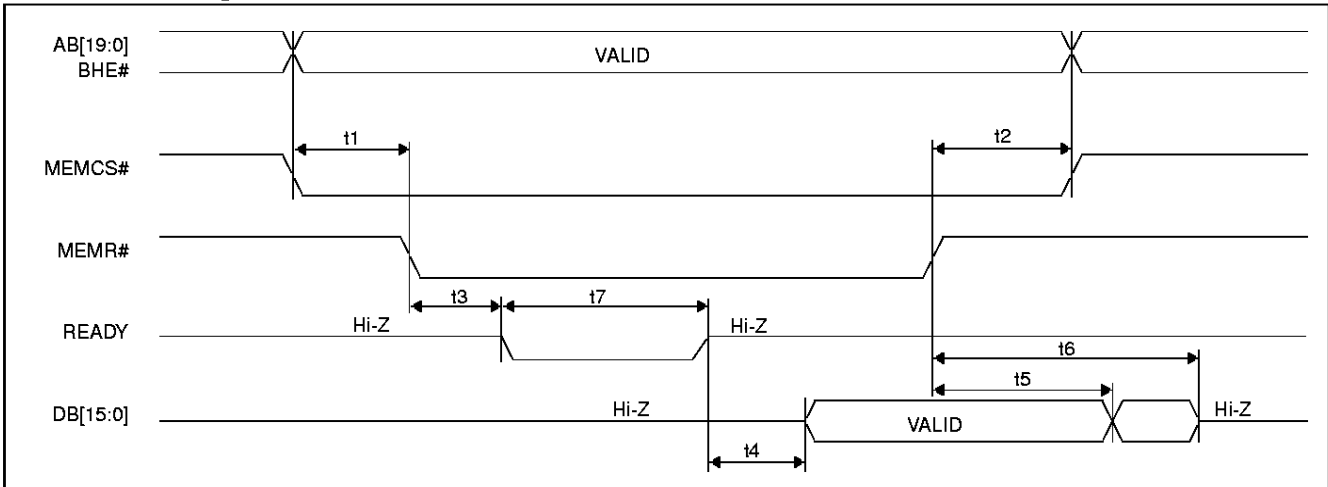

Figure 17: MEMR# Timing (Non-MC68000)

Table 7-8: MEMR# Timing (Non-MC68000)

Symbol	Parameter	3V/3.3V		5V		Units
		Min	Max	Min	Max	
t1	AB[19:0], BHE# and MEMCS# valid before MEMR# falling edge	0		0		ns
t2	AB[19:0], BHE# and MEMCS# hold from MEMR# rising edge	0		0		ns
t3	MEMR# falling edge to READY falling edge		30		20	ns
t4	READY rising edge to DB[15:0] valid		15		10	ns
t5	DB[15:0] hold from MEMR# rising edge		20		10	ns
t6	MEMR# rising edge to DB[15:0] hi-z delay		30		20	ns
t7	READY negated pulse width		3.5* MCLK + 20		3.5* MCLK + 10	ns

Where MCLK =  $1/f_{OSC}$ ,  $2/f_{OSC}$ , or  $4/f_{OSC}$  depending on which display mode the chip is in. (See section 9.2 and 9.3.)



## 7.2 Clock Input Requirements

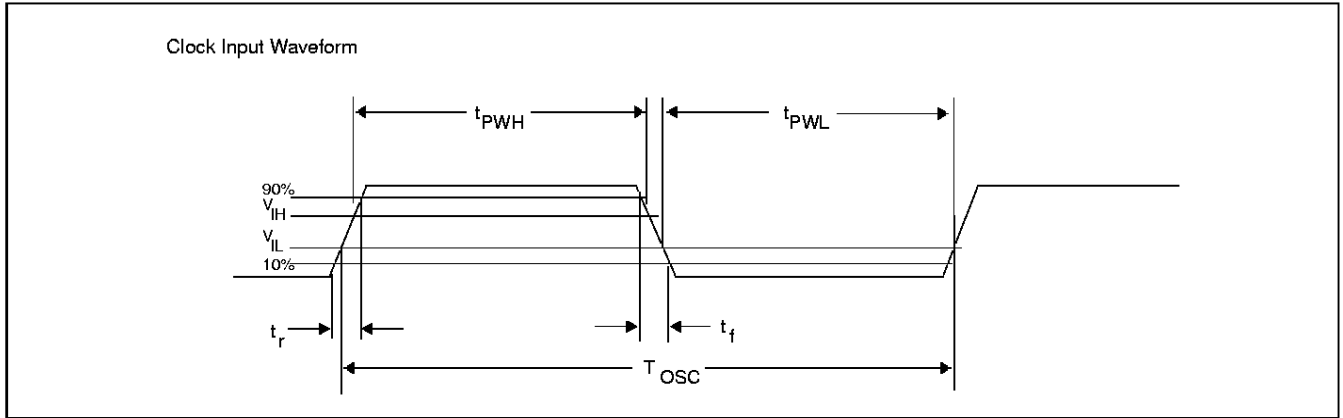

Figure 18: Clock Input Requirements

Table 7-9: Clock Input Requirements

Symbol	Parameter	Min	Typ	Max	Units
$T_{OSC}$	Input Clock Period (CLKI)	40			ns
$t_{PWH}$	Input Clock Pulse Width High (CLKI)	40%		60%	$T_{OSC}$
$t_{PWL}$	Input Clock Pulse Width Low (CLKI)	40%		60%	$T_{OSC}$
$t_f$	Input Clock Fall Time (10% - 90%)		5		ns
$t_r$	Input Clock Rise Time (10% - 90%)		5		ns

## 7.2.1 Recommended Clock Input

The nominal frequency must be calculated based on the formulas found in Frame Rate Calculation on page 84.

The crystal oscillator must be “fundamental mode” and have the following recommended RC load values:

$$R_L = 2M\Omega \pm 5\%$$

$$C_L = 6.8 \text{ pF}$$

The figure below demonstrates both a crystal interface and an oscillator interface to the SED1353.

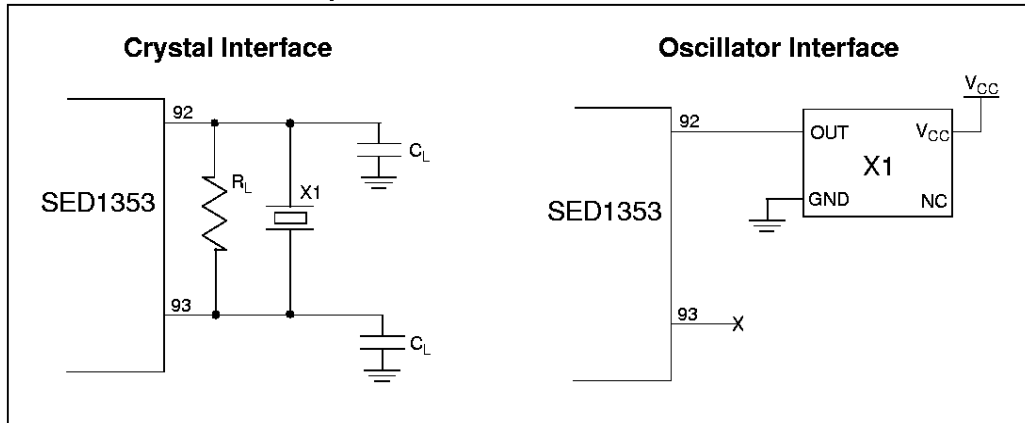

Figure 19: Recommended Clock Interface

## 7.3 Display Memory Interface Timing

### 7.3.1 Write Data to Display Memory

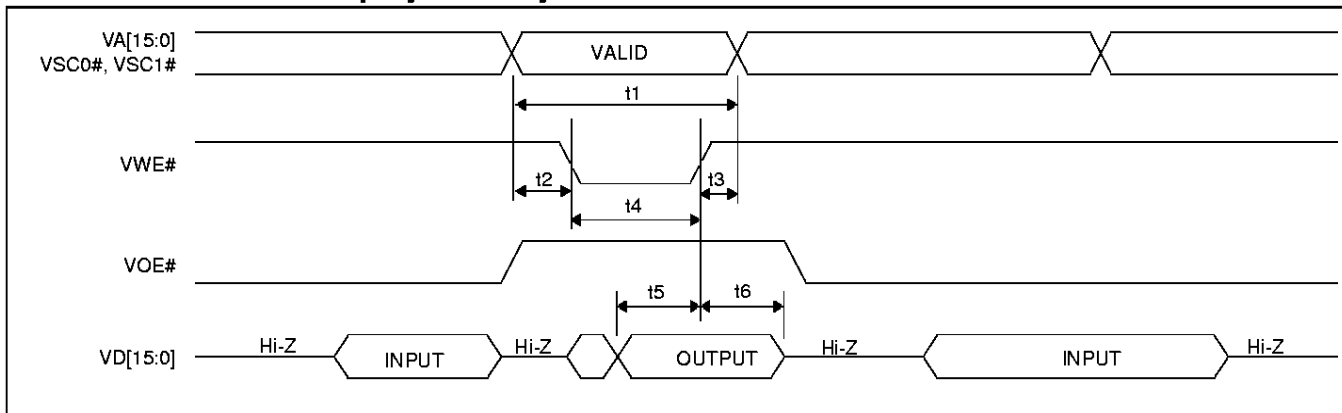

Figure 20: Write Data to Display Memory

Table 7-10: Write Data to Display Memory

Symbol	Parameter	3V/3.3V		5V		Units
		Min	Max	Min	Max	
t1	Address cycle time	MCLK - 15		MCLK - 10		ns
t2	VA[15:0], VCS0# and VCS1# valid before VWE# falling edge	0		0		ns
t3	VA[15:0], VCS0# and VCS1# hold from VWE# rising edge	0		0		ns
t4	Pulse width of VWE#	MCLK - 15		MCLK - 10		ns
t5	VD[15:0] setup to VWE# rising edge	MCLK - 20		MCLK - 15		ns
t6	VD[15:0] hold from VWE# rising edge	0		0		ns

Where MCLK =  $1/f_{OSC}$ , or  $2/f_{OSC}$ , or  $4/f_{OSC}$  depending on which display mode the chip is in. (See section 9.2 and 9.3.)

### 7.3.2 Read Data From Display Memory

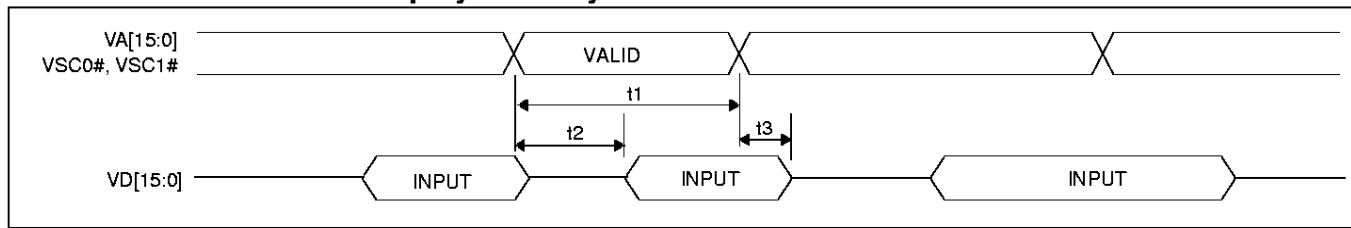

Figure 21: Read Data From Display Memory

Table 7-11: Read Data From Display Memory

Symbol	Parameter	3V/3.3V		5V	
		Min	Max	Min	Max
t1	Address cycle time	MCLK - 15		MCLK - 10	
t2	VA[15:0], VCS0# and VCS1# access time		MCLK - 40		MCLK - 25
t3	VD[15:0] hold time	0		0	

Where  $MCLK = 1/f_{OSC}$ , or  $2/f_{OSC}$ , or  $4/f_{OSC}$  depending on which display mode the chip is in. (See section 9.2 and 9.3.)

## 7.4 LCD Interface

### 7.4.1 LCD Interface Timing - 4-Bit Single, 8-Bit Single/Dual Monochrome Panels

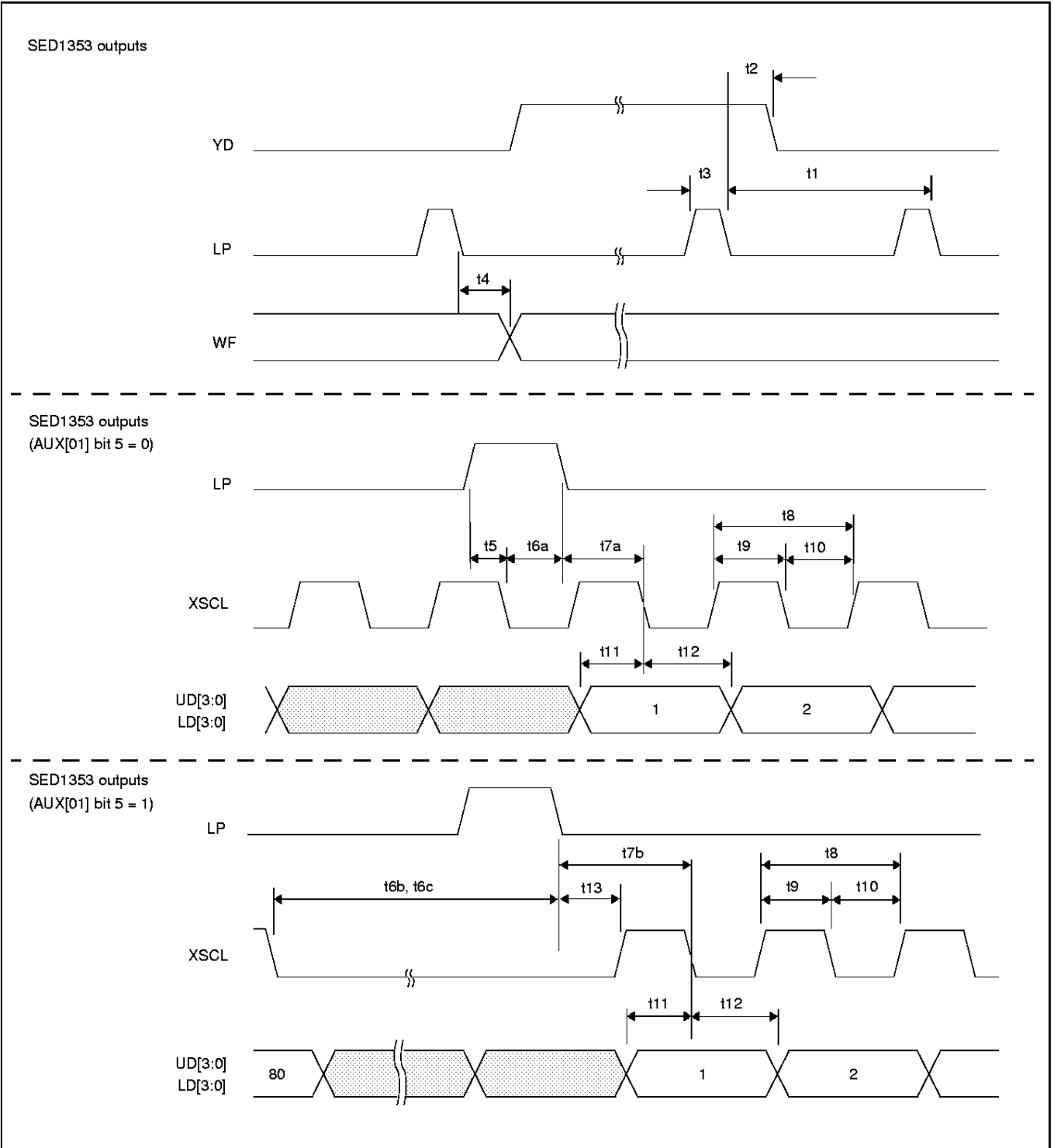

Figure 22: LCD Interface Timing - Monochrome Panel

Table 7-12: LCD Interface Timing - 4-Bit Single and 8-Bit Single/Dual Monochrome Panel

Symbol	Parameter	4-Bit Single		8-Bit Single/Dual		Units
		Min	Max	Min	Max	
t1	LP period (single panel mode)	HT + HNDP - 10		HT + HNDP - 10		ns
t1	LP period (dual panel mode)	n/a		2(HT + HNDP) - 10		ns
t2	YD hold from LP falling edge (AUX[01] bit 5 = 0)	8t <sub>OSC</sub> - 10		8t <sub>OSC</sub> - 10		ns
t2	YD hold from LP falling edge (AUX[01] bit 5 = 1)	13t <sub>OSC</sub> - 10		13t <sub>OSC</sub> - 10		ns
t3	LP pulse width (AUX[01] bit 5 = 0)	6t <sub>OSC</sub> - 5		6t <sub>OSC</sub> - 5		ns
t3	LP pulse width (AUX[01] bit 5 = 1)	5t <sub>OSC</sub> - 5		5t <sub>OSC</sub> - 5		ns
t4	WF delay from LP falling edge	0	20	0	20	ns
t5	LP setup to XSCL falling edge (AUX[01] bit 5 = 0 and AUX[03] bit 2 = 0)	n/a		2t <sub>OSC</sub> - 5		ns
t6a	LP hold from XSCL falling edge (AUX[01] bit 5 = 0 and AUX[03] bit 2 = 0)	2t <sub>OSC</sub> - 5		4t <sub>OSC</sub> - 5		ns
t6a	LP hold from XSCL falling edge (AUX[01] bit 5 = 0 and AUX[03] bit 2 = 1)	t <sub>OSC</sub> - 5		2t <sub>OSC</sub> - 5		ns
t6b	XSCL falling edge to LP falling edge - single panel mode (AUX[01] bit 5 = 1 and AUX[03] bit 2 = 0)	13t <sub>OSC</sub> - 5		15t <sub>OSC</sub> - 5		ns
t6b	XSCL falling edge to LP falling edge - single panel mode (AUX[01] bit 5 = 1 and AUX[03] bit 2 = 1)	12t <sub>OSC</sub> - 5		13t <sub>OSC</sub> - 5		ns
t6c	XSCL falling edge to LP falling edge - dual panel mode (AUX[01] bit 5 = 1 and AUX[03] bit 2 = 0)	n/a		31t <sub>OSC</sub> - 5		ns
t6c	XSCL falling edge to LP falling edge - dual panel mode (AUX[01] bit 5 = 1 and AUX[03] bit 2 = 1)	n/a		29t <sub>OSC</sub> - 5		ns
t7a	LP falling edge to XSCL falling edge (AUX[01] bit 5 = 0 and AUX[03] bit 2 = 0)	2t <sub>OSC</sub> - 5		4t <sub>OSC</sub> - 5		ns
t7a	LP falling edge to XSCL falling edge (AUX[01] bit 5 = 0 and AUX[03] bit 2 = 1)	t <sub>OSC</sub> - 5		2t <sub>OSC</sub> - 5		ns
t7b	LP falling edge to XSCL falling edge (AUX[01] bit 5 = 1 and AUX[03] bit 2 = 0)	7t <sub>OSC</sub> - 5		9t <sub>OSC</sub> - 5		ns
t7b	LP falling edge to XSCL falling edge (AUX[01] bit 5 = 1 and AUX[03] bit 2 = 1)	6t <sub>OSC</sub> - 5		7t <sub>OSC</sub> - 5		ns
t8	XSCL period (AUX[03] bit 2 = 0)	4t <sub>OSC</sub> - 5		8t <sub>OSC</sub> - 5		ns
t8	XSCL period (AUX[03] bit 2 = 1)	2t <sub>OSC</sub> - 5		4t <sub>OSC</sub> - 5		ns
t9	XSCL high width (AUX[03] bit 2 = 0)	2t <sub>OSC</sub> - 5		4t <sub>OSC</sub> - 5		ns
t9	XSCL high width (AUX[03] bit 2 = 1)	t <sub>OSC</sub> - 5		2t <sub>OSC</sub> - 5		ns
t10	XSCL low width (AUX[03] bit 2 = 0)	2t <sub>OSC</sub> - 10		4t <sub>OSC</sub> - 10		ns
t10	XSCL low width (AUX[03] bit 2 = 1)	t <sub>OSC</sub> - 10		2t <sub>OSC</sub> - 10		ns
t11	UD[3:0], LD[3:0] setup to XSCL falling edge (AUX[03] bit 2 = 0)	2t <sub>OSC</sub> - 10**		4t <sub>OSC</sub> - 10**		ns

Table 7-12: LCD Interface Timing - 4-Bit Single and 8-Bit Single/Dual Monochrome Panel

t11	UD[3:0], LD[3:0] setup to XSCL falling edge (AUX[03] bit 2 = 1)	$t_{OSC} - 10^{**}$		$2t_{OSC} - 10^{**}$		ns
t12	UD[3:0], LD[3:0] hold from XSCL falling edge (AUX[03] bit 2 = 0)	$2t_{OSC} - 10$		$4t_{OSC} - 10$		ns
t12	UD[3:0], LD[3:0] hold from XSCL falling edge (AUX[03] bit 2 = 1)	$t_{OSC} - 10$		$2t_{OSC} - 10$		ns
t13	LP falling edge to XSCL rising edge (AUX[01] bit 5 = 1)	$5t_{OSC} - 5$		$5t_{OSC} - 5$		ns

Where  $t_{OSC} = 1/f_{OSC}$  = input (pixel) clock period,

where HT = (number of horizontal panel pixels) \*  $t_{OSC}$ ,

where HNDP = horizontal non-display period in units of  $t_{OSC}$  (see Section 9.3 on page 84 for details).

\*\* -10 ns for 5V operation, - 24 ns for 3.0V and 3.3V operation.

### 7.4.2 LCD Interface Timing - 4-Bit Single Color Panel

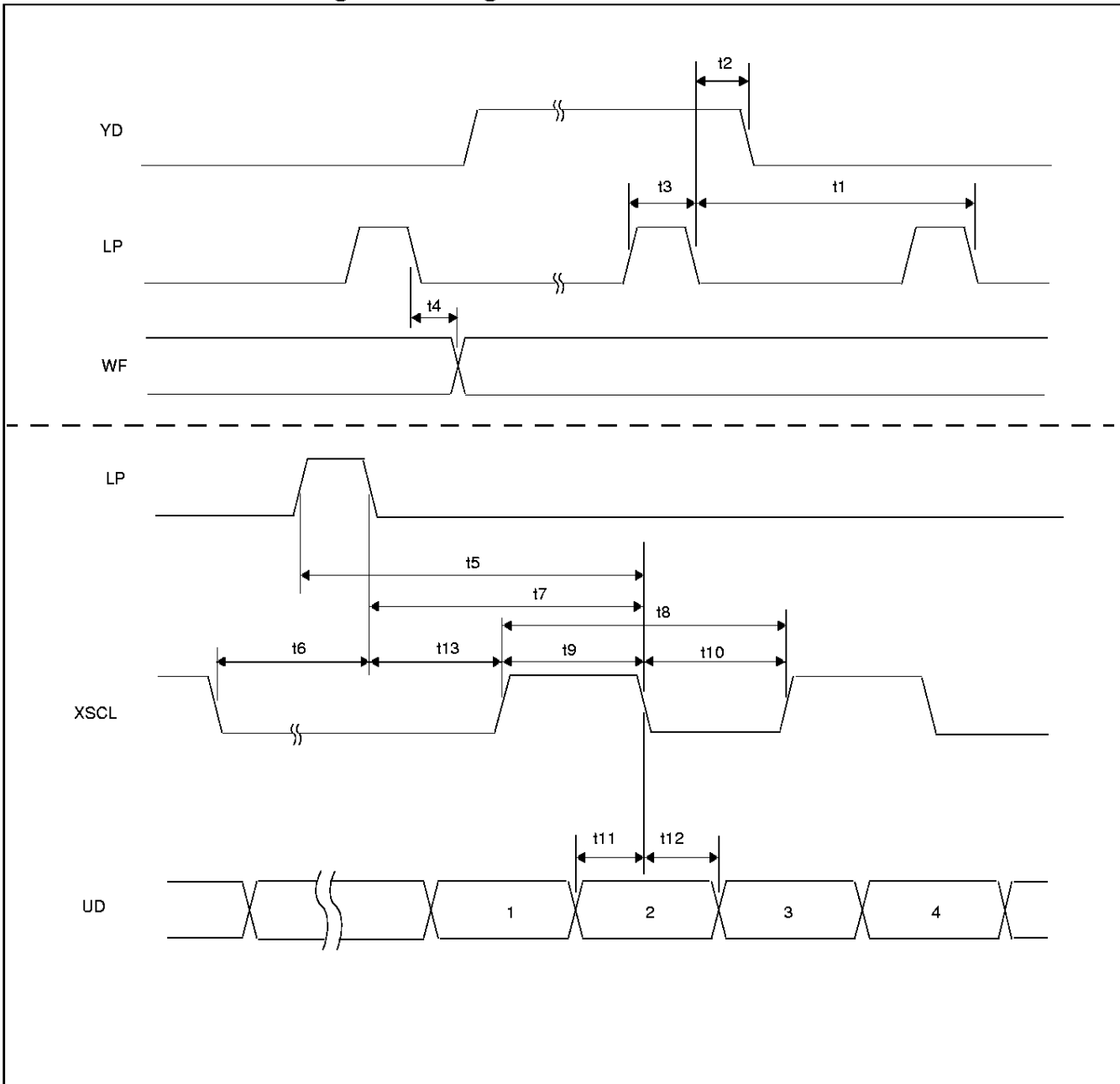

Figure 23: LCD Interface Timing - 4-Bit Single Color Panel



Table 7-13: LCD Interface Timing - 4-Bit Single Color Panel

Symbol	Parameter	Min	Typ	Max	Units
t1	LP period	HT + HNDDP - 10			ns
t2	YD hold from LP falling edge	13t <sub>OSC</sub> - 10			ns
t3	LP pulse width	5t <sub>OSC</sub> - 5			ns
t4	WF delay from LP falling edge	0		20	ns
t5	LP setup to XSCL falling edge	19t <sub>OSC</sub> - 5			ns
t6	XSCL falling edge to LP falling edge	20t <sub>OSC</sub> - 5			ns
t7	LP falling edge to XSCL falling edge	14t <sub>OSC</sub> - 5			ns
t8	XSCL period	t <sub>OSC</sub> - 5			ns
t9	XSCL high width	0.5t <sub>OSC</sub> - 5			ns
t10	XSCL low width	0.5t <sub>OSC</sub> - 5			ns
t11	UD setup to XSCL falling edge	0.5t <sub>OSC</sub> - 10**			ns
t12	UD hold from XSCL falling edge	0.5t <sub>OSC</sub> - 10			ns
t13	LP falling edge to XSCL rising edge	13.5t <sub>OSC</sub> - 10			ns

Where t<sub>OSC</sub> = 1/f<sub>OSC</sub> = input (pixel) clock period,  
 where HT = (number of horizontal panel pixels) \* t<sub>OSC</sub>,  
 where HNDDP = horizontal non-display period in units of t<sub>OSC</sub> (see Section 9.3 on page 84 for details).  
 \*\* 5V operation, for 3.0V and 3.3V operation T11 will be 0.5t<sub>OSC</sub> - 24.

### 7.4.3 LCD Interface Timing - 8-Bit Single Color Panels Format 2/8-Bit Dual Color Panels

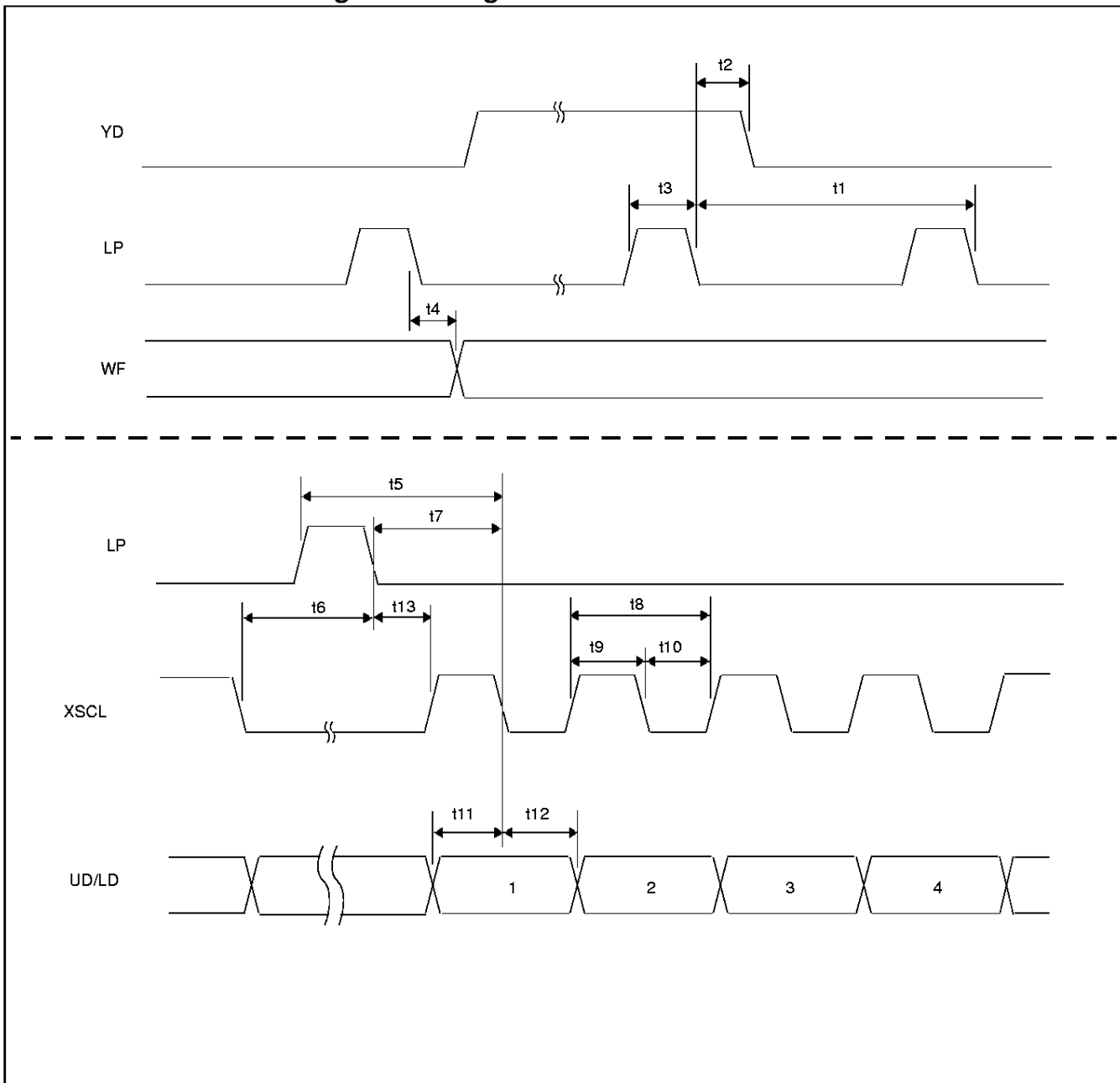

Figure 24: LCD Interface Timing - 8-Bit Single Color Panels Format 2/8-Bit Dual Color Panels

Table 7-14: LCD Interface Timing - 8-Bit Single Color Panels Format 2/8-Bit Dual Color Panels

Symbol	Parameter	Min	Typ	Max	Units
t1	LP period (single panel mode)	HT + HNDDP - 10			ns
t1	LP period (dual panel mode)	2(HT + HNDDP) - 10			ns
t2	YD hold from LP falling edge	13t <sub>OSC</sub> - 10			ns
t3	LP pulse width	5t <sub>OSC</sub> - 5			ns
t4	WF delay from LP falling edge	0		20	ns
t5	LP setup to XSCL falling edge	19.5t <sub>OSC</sub> - 5			ns
t6	XSCL falling edge to LP falling edge (single panel mode)	20t <sub>OSC</sub> - 5			ns
t6	XSCL falling edge to LP falling edge (dual panel mode)	52t <sub>OSC</sub> - 5			ns
t7	LP falling edge to XSCL falling edge	14.5t <sub>OSC</sub> - 5			ns
t8	XSCL period	2.5t <sub>OSC</sub> - 5			ns
t9	XSCL high width	t <sub>OSC</sub> - 5			ns
t10	XSCL low width	1.5t <sub>OSC</sub> - 5			ns
t11	UD/LD setup to XSCL falling edge	1.5t <sub>OSC</sub> - 10**			ns
t12	UD/LD hold from XSCL falling edge	t <sub>OSC</sub> - 5			ns
t13	LP falling edge to XSCL rising edge	13.5t <sub>OSC</sub> - 10			ns

Where t<sub>OSC</sub> = 1/f<sub>OSC</sub> = input (pixel) clock period,  
 where HT = (number of horizontal panel pixels) \* t<sub>OSC</sub>,  
 where HNDDP = horizontal non-display period in units of t<sub>OSC</sub> (see Section 9.3 on page 84 for details).  
 \*\* 5V operation, for 3.0V and 3.3V operation T11 will be 1.5t<sub>OSC</sub> - 24.

### 7.4.4 LCD Interface Timing - 16-Bit Single/Dual Color Panels

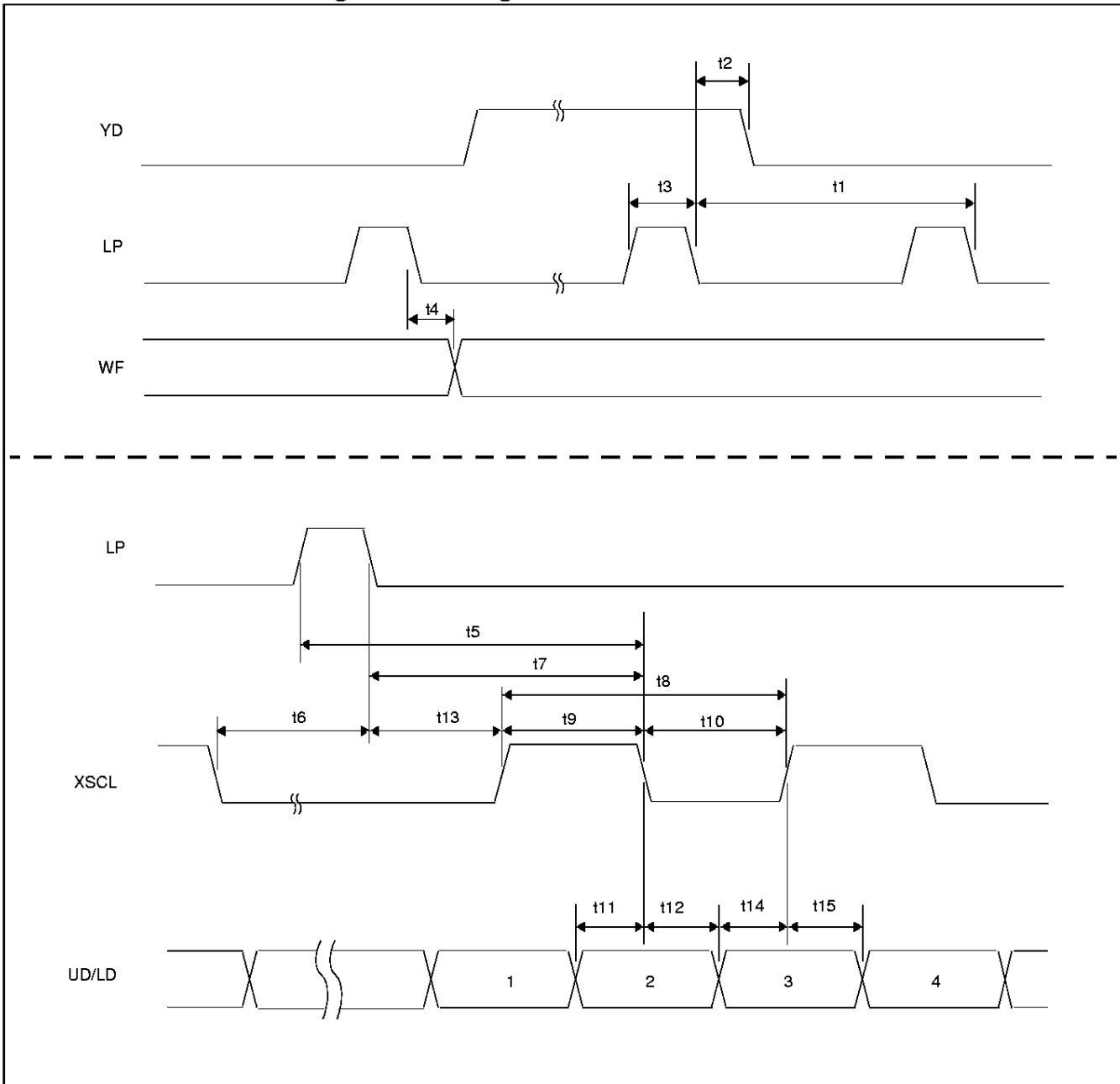

Figure 25: LCD Interface Timing - 16-Bit Single/Dual Color Panels

Table 7-15: LCD Interface Timing - 16-Bit Single/Dual Color Panels

Symbol	Parameter	Min	Typ	Max	Units
t1	LP period (single panel mode)	HT + HNDP - 10			ns
t1	LP period (dual panel mode)	2(HT + HNDP) - 10			ns
t2	YD hold from LP falling edge	13t <sub>OSC</sub> - 10			ns
t3	LP pulse width	5t <sub>OSC</sub> - 5			ns
t4	WF delay from LP falling edge	0		20	ns
t5	LP setup to XSCL falling edge	22t <sub>OSC</sub> - 5			ns
t6	XSCL falling edge to LP falling edge (single panel mode)	20t <sub>OSC</sub> - 5			ns
t6	XSCL falling edge to LP falling edge (dual panel mode)	52t <sub>OSC</sub> - 5			ns
t7	LP falling edge to XSCL falling edge	17t <sub>OSC</sub> - 5			ns
t8	XSCL period	5t <sub>OSC</sub> - 5			ns
t9	XSCL high width	2t <sub>OSC</sub> - 5			ns
t10	XSCL low width	3t <sub>OSC</sub> - 10			ns
t11	UD/LD setup to XSCL falling edge	1.5t <sub>OSC</sub> - 10**			ns
t12	UD/LD hold from XSCL falling edge	t <sub>OSC</sub> - 5			ns
t13	LP falling edge to XSCL rising edge	15t <sub>OSC</sub> - 10			ns
t14	UD/LD setup to XSCL rising edge	1.5t <sub>OSC</sub> - 10			ns
t15	UD/LD hold from XSCL rising edge	0.5t <sub>OSC</sub> - 5			ns

Where t<sub>OSC</sub> = 1/f<sub>OSC</sub> = input (pixel) clock period,

where HT = (number of horizontal panel pixels) \* t<sub>OSC</sub>,

where HNDP = horizontal non-display period in units of t<sub>OSC</sub> (see Section 9.3 on page 84 for details).

\*\* 5V operation, for 3.0V and 3.3V operation T11 will be 1.5t<sub>OSC</sub> - 24.

### 7.4.5 LCD Interface Timing - 8-Bit Single Color Panels Format 1

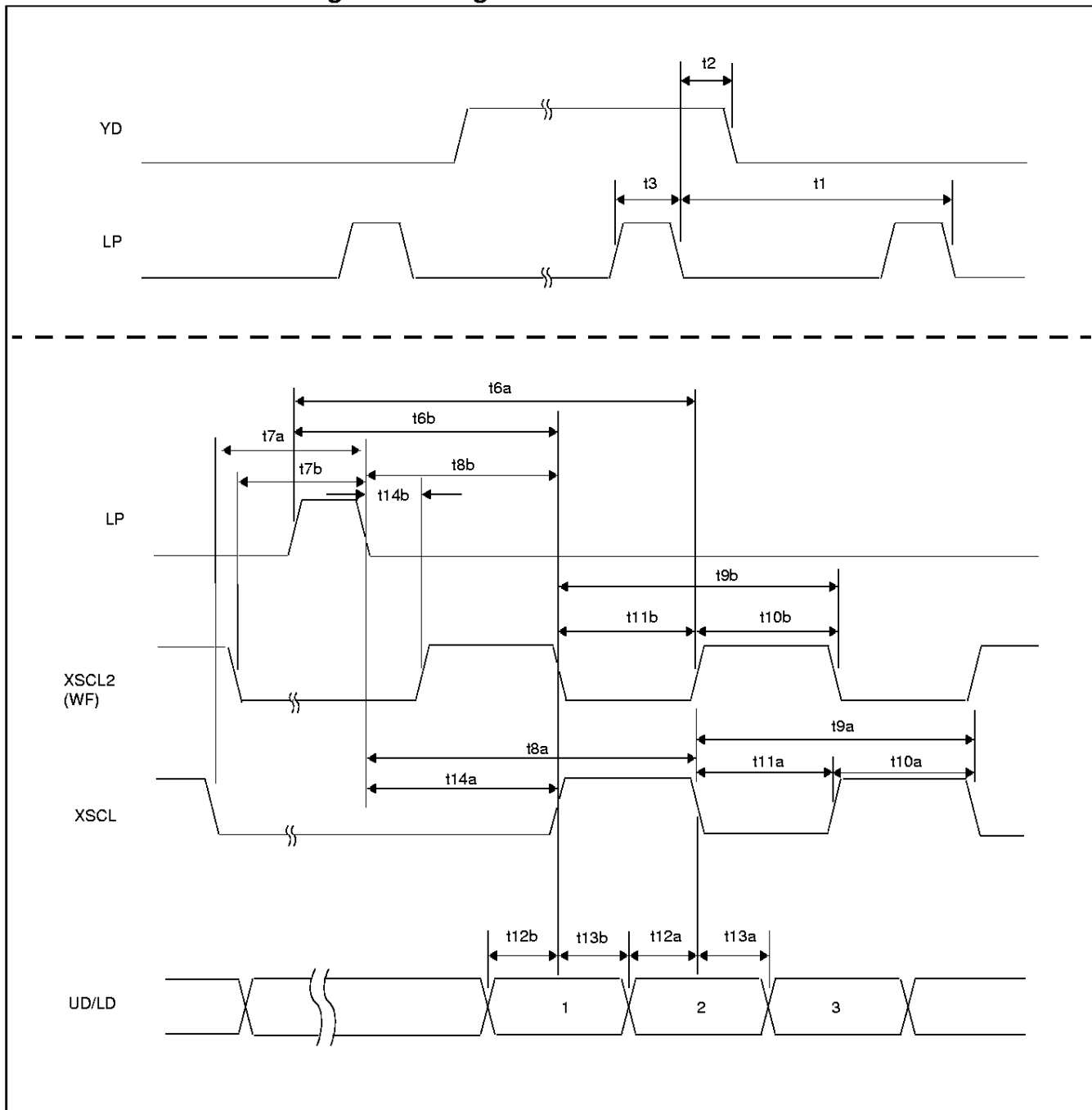

Figure 26: LCD Interface Timing - 8-Bit Single Color Panels Format 1

Table 7-16: LCD Interface Timing - 8-Bit Single Color Panels Format 1

Symbol	Parameter	Min	Typ	Max	Units
t1	LP period	HT + HNDP - 10			ns
t2	YD hold from LP falling edge	13t <sub>OSC</sub> - 10			ns
t3	LP pulse width	5t <sub>OSC</sub> - 5			ns
t6a	LP setup to XSCL falling edge	22t <sub>OSC</sub> - 5			ns
t6b	LP setup to XSCL2 falling edge	19.5t <sub>OSC</sub> - 5			ns
t7a	XSCL falling edge to LP falling edge	20t <sub>OSC</sub> - 5			ns
t7b	XSCL2 falling edge to LP falling edge	23.5t <sub>OSC</sub> - 5			ns
t8a	LP falling edge to XSCL falling edge	17t <sub>OSC</sub> - 5			ns
t8b	LP falling edge to XSCL2 falling edge	14.5t <sub>OSC</sub> - 5			ns
t9a	XSCL period	4t <sub>OSC</sub> - 5			ns
t9b	XSCL2 period	4t <sub>OSC</sub> - 5			ns
t10a	XSCL high width	t <sub>OSC</sub> - 5			ns
t10b	XSCL2 high width	t <sub>OSC</sub> - 5			ns
t11a	XSCL low width	3t <sub>OSC</sub> - 10			ns
t11b	XSCL2 low width	3t <sub>OSC</sub> - 10			ns
t12a	UD/LD setup to XSCL falling edge	1.5t <sub>OSC</sub> - 10**			ns
t12b	UD/LD setup to XSCL2 falling edge	1.5t <sub>OSC</sub> - 10**			ns
t13a	UD/LD hold from XSCL falling edge	t <sub>OSC</sub> - 5			ns
t13b	UD/LD hold from XSCL2 falling edge	t <sub>OSC</sub> - 5			ns
t14a	LP falling edge to XSCL rising edge	16t <sub>OSC</sub> - 10			ns
t14b	LP falling edge to XSCL2 rising edge	13.5t <sub>OSC</sub> - 10			ns

Where t<sub>OSC</sub> = 1/f<sub>OSC</sub> = input (pixel) clock period,

where HT = (number of horizontal panel pixels) \* t<sub>OSC</sub>,

where HNDP = horizontal non-display period in units of t<sub>OSC</sub> (see Section 9.3 on page 84 for details).

\*\* 5V operation, for 3.0V and 3.3V operation T12 will be 1.5t<sub>OSC</sub> - 24.

### 7.4.6 LCD Interface Options

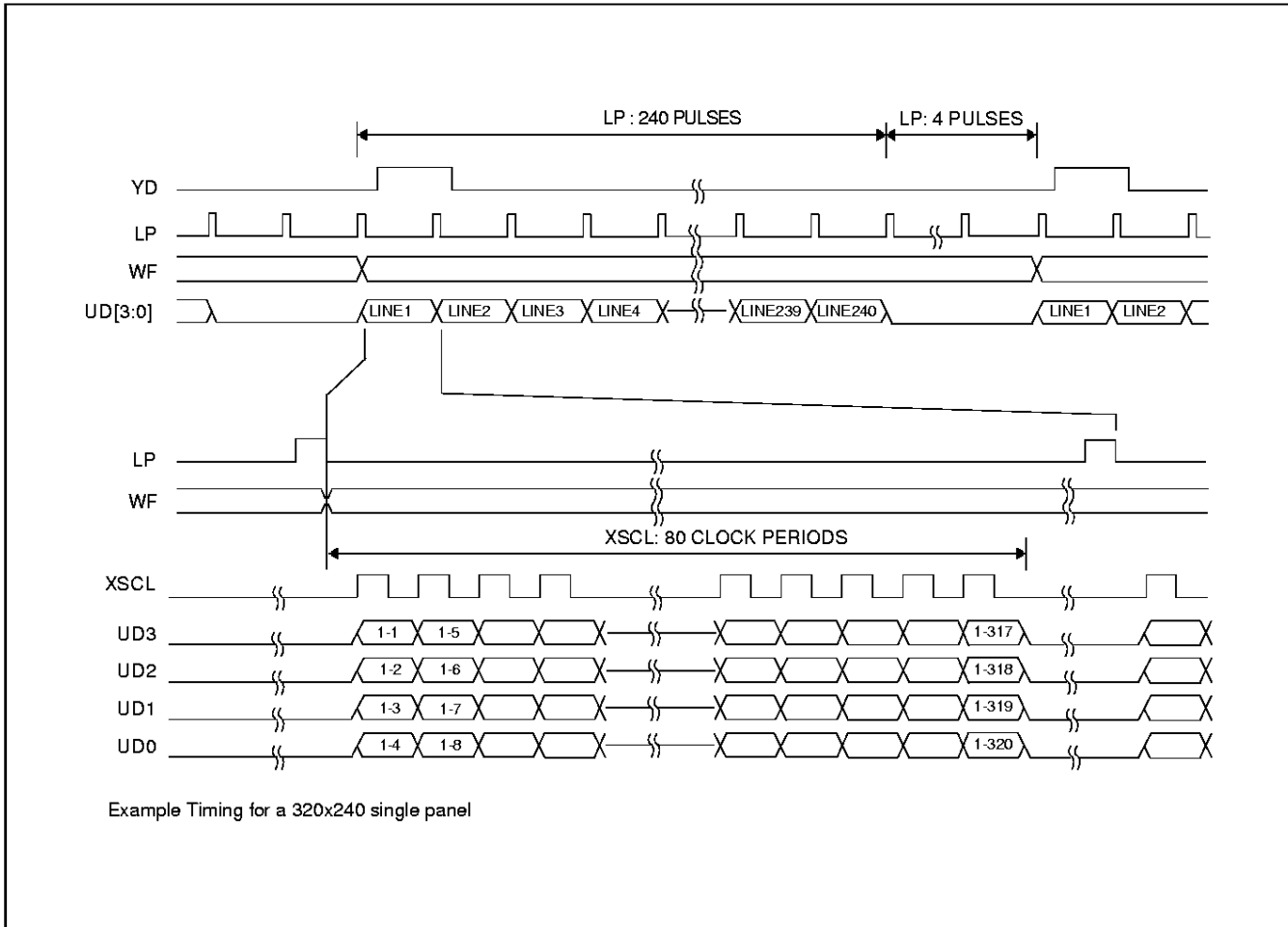

Figure 27: 4-Bit Single Monochrome Panel Timing



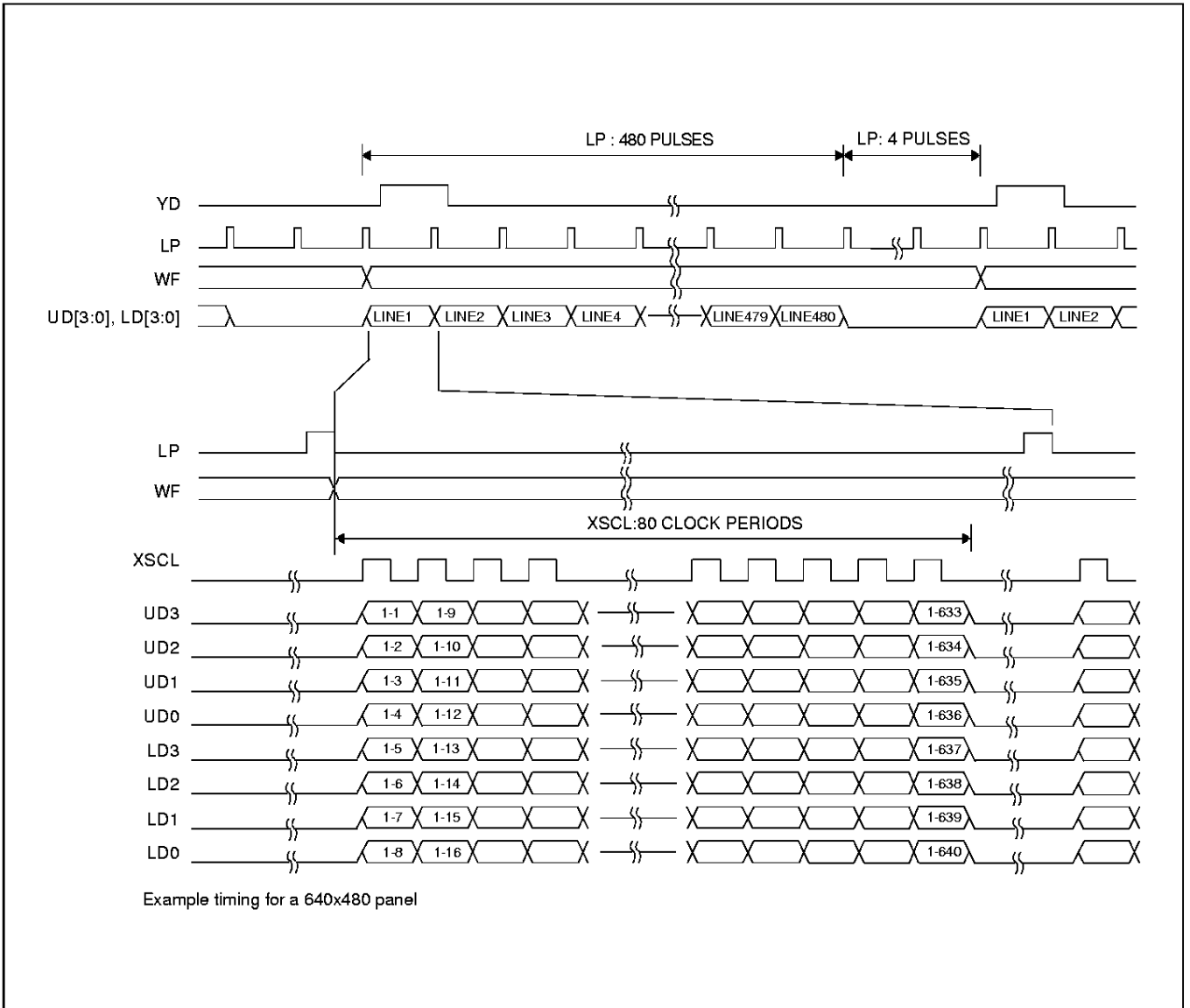

Figure 28: 8-Bit Single Monochrome Panel Timing

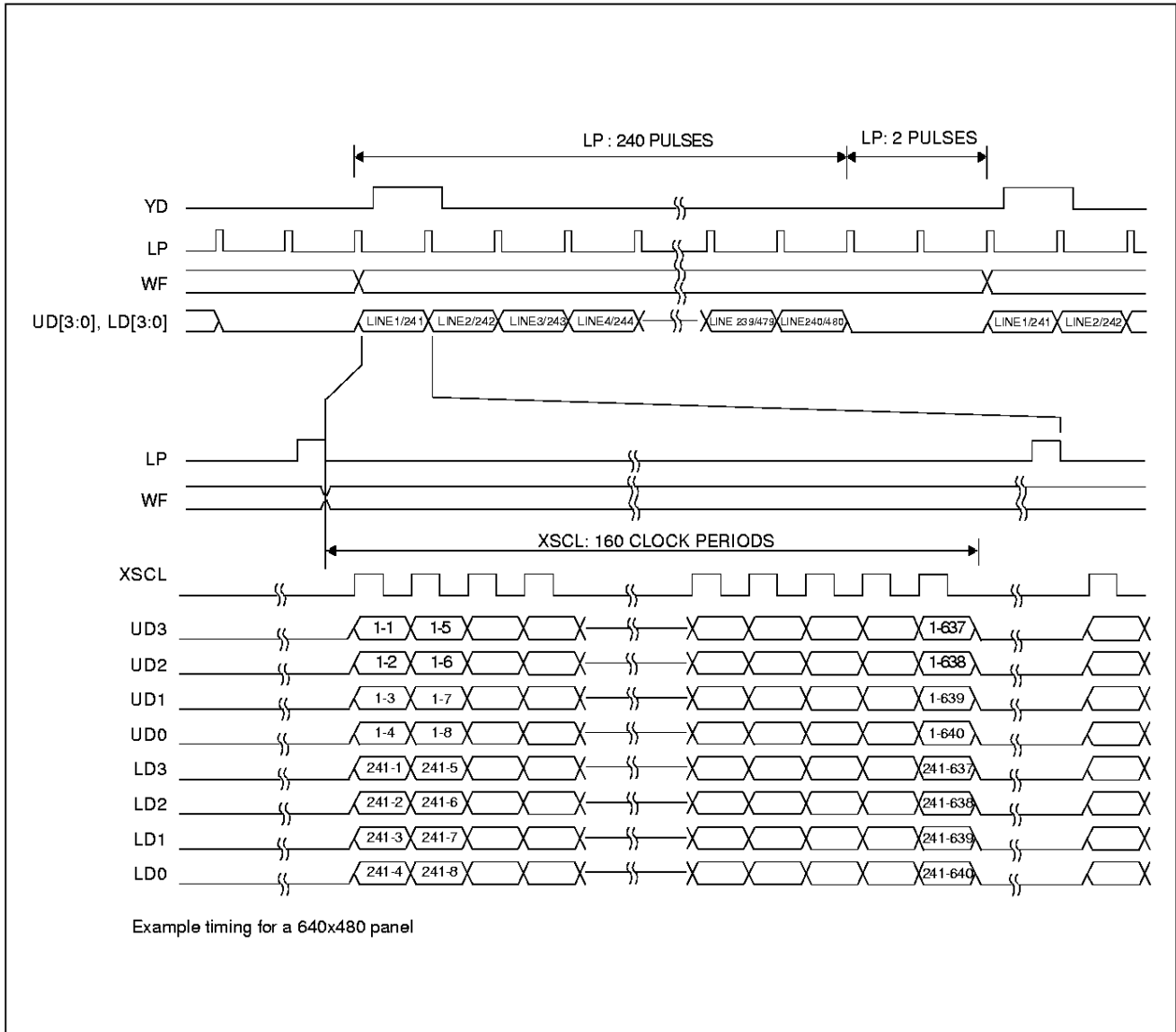

Figure 29: 8-Bit Dual Monochrome Panel Timing

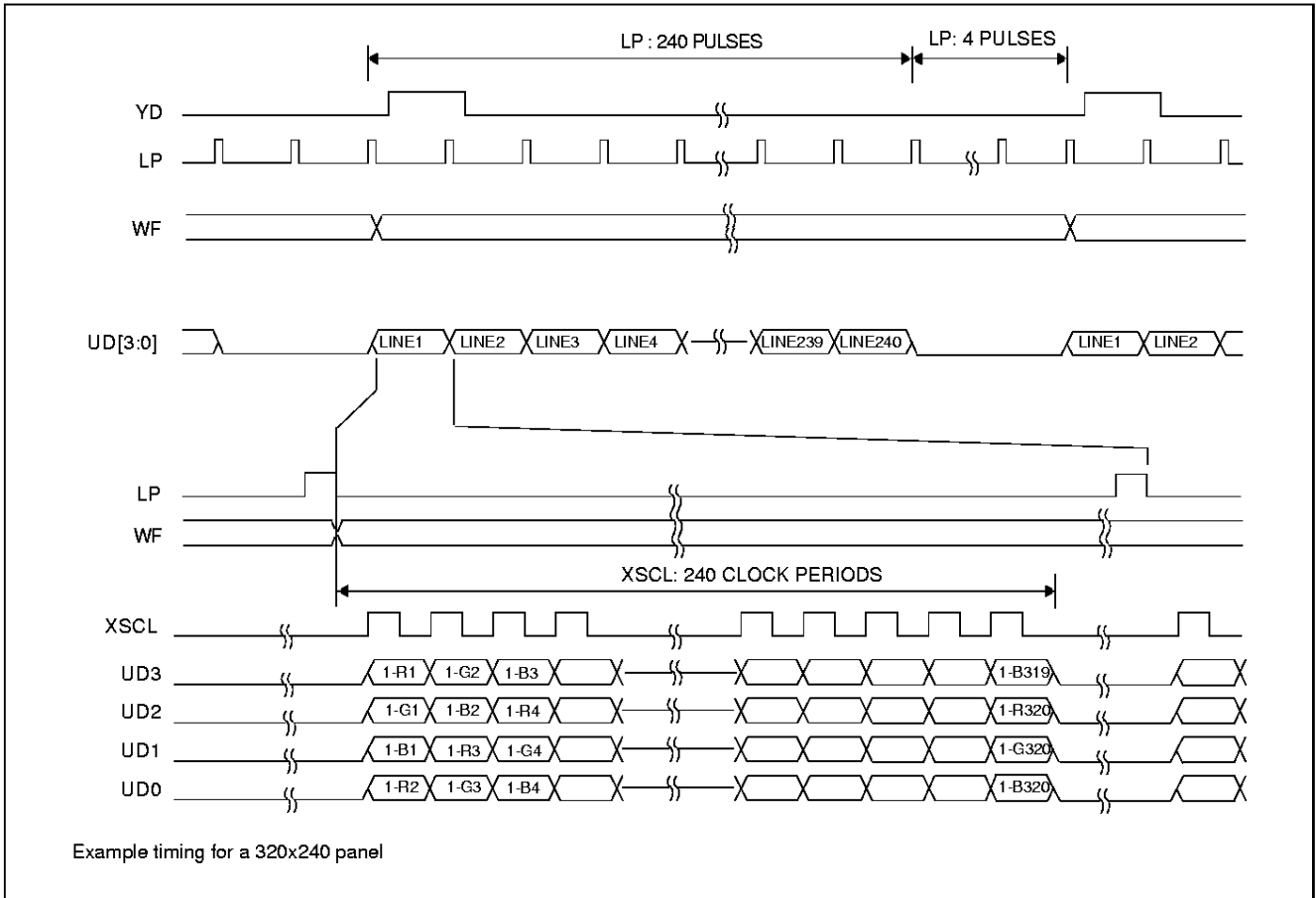

Figure 30: 4-Bit Single Color Panel Timing

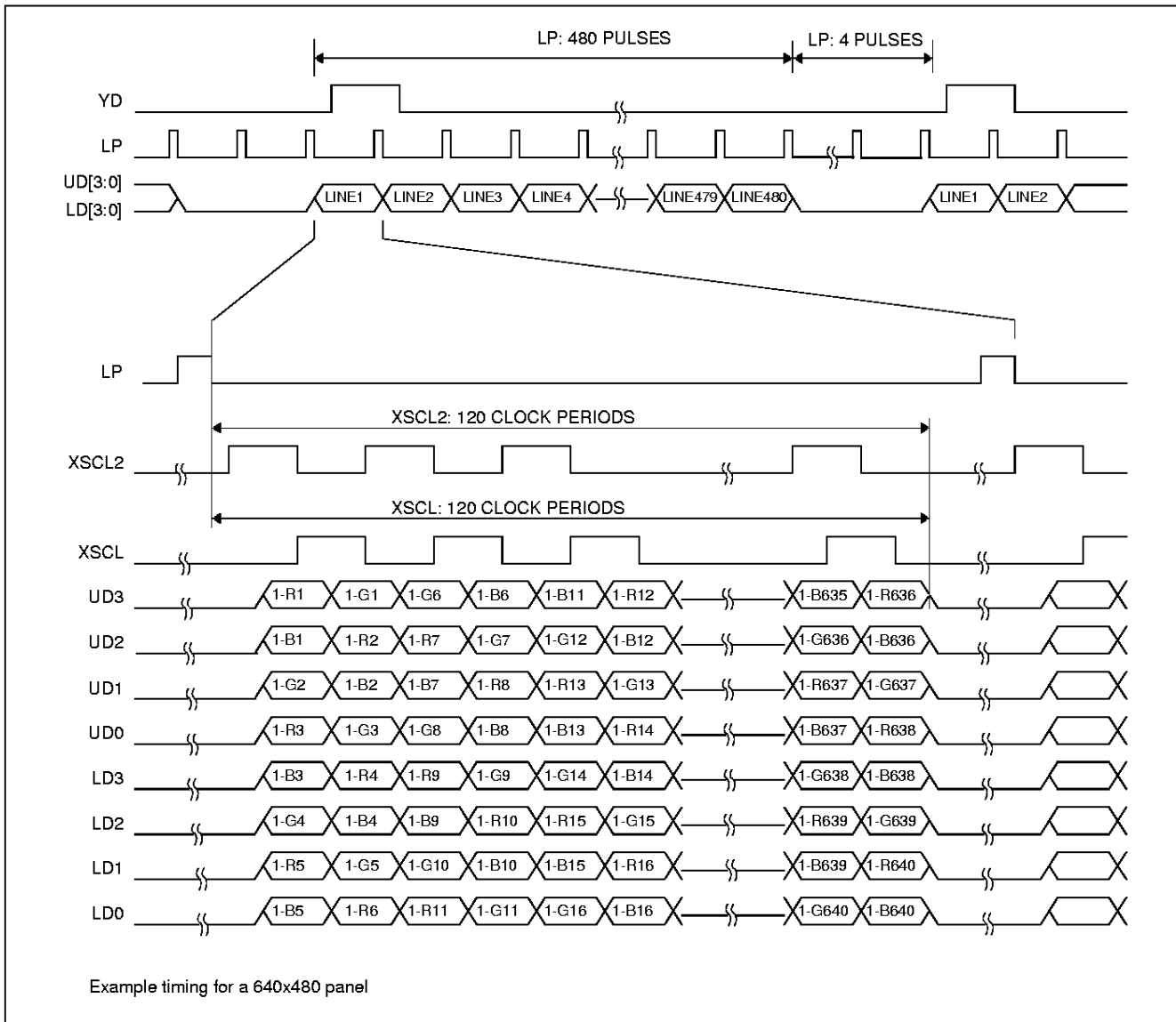

Figure 31: 8-Bit Single Color Panel Timing - Format 1 : AUX[03] Bit 3 = 0 and AUX[01] Bit 2 = 1

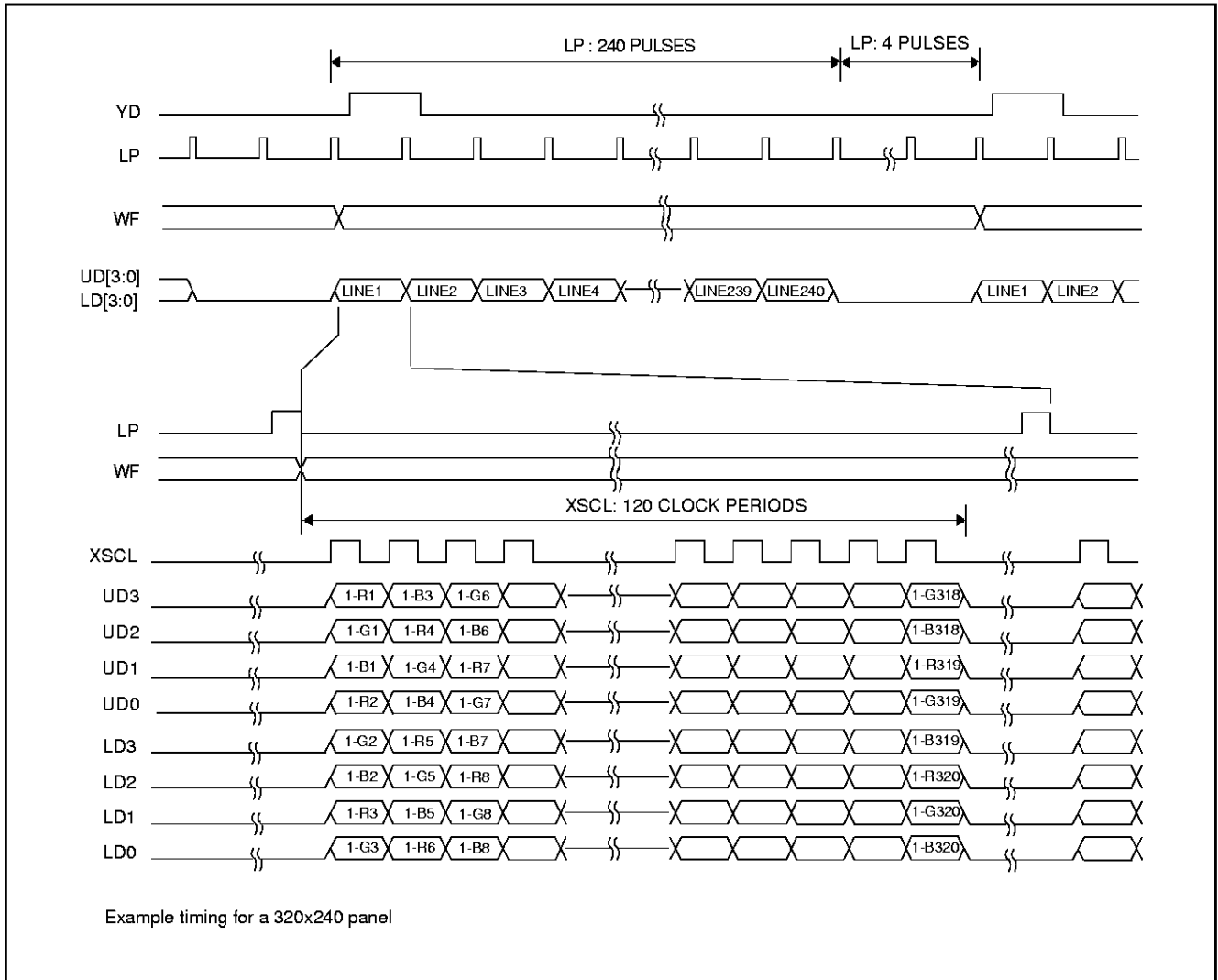

Figure 32: 8-Bit Single Color Panel Timing - Format 2 : AUX[03] Bit 3 = 1 and AUX[01] Bit 2 = 1

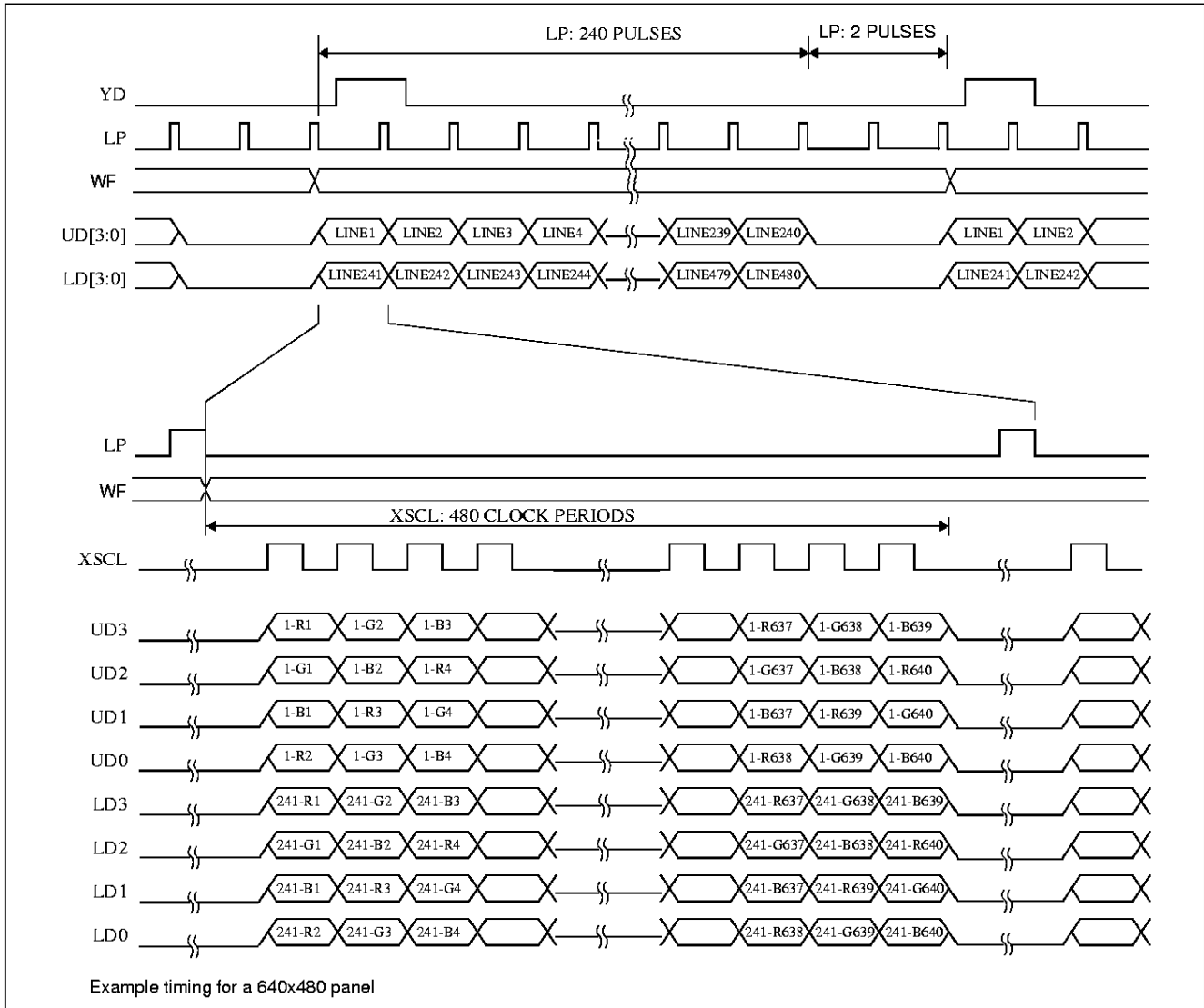

Figure 33: 8-Bit Dual Color Panel Timing

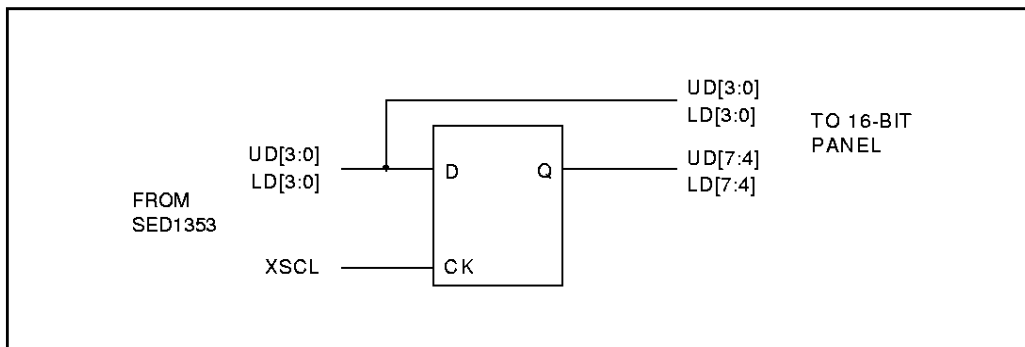

Figure 34: External Circuit Required for 16-Bit Panel

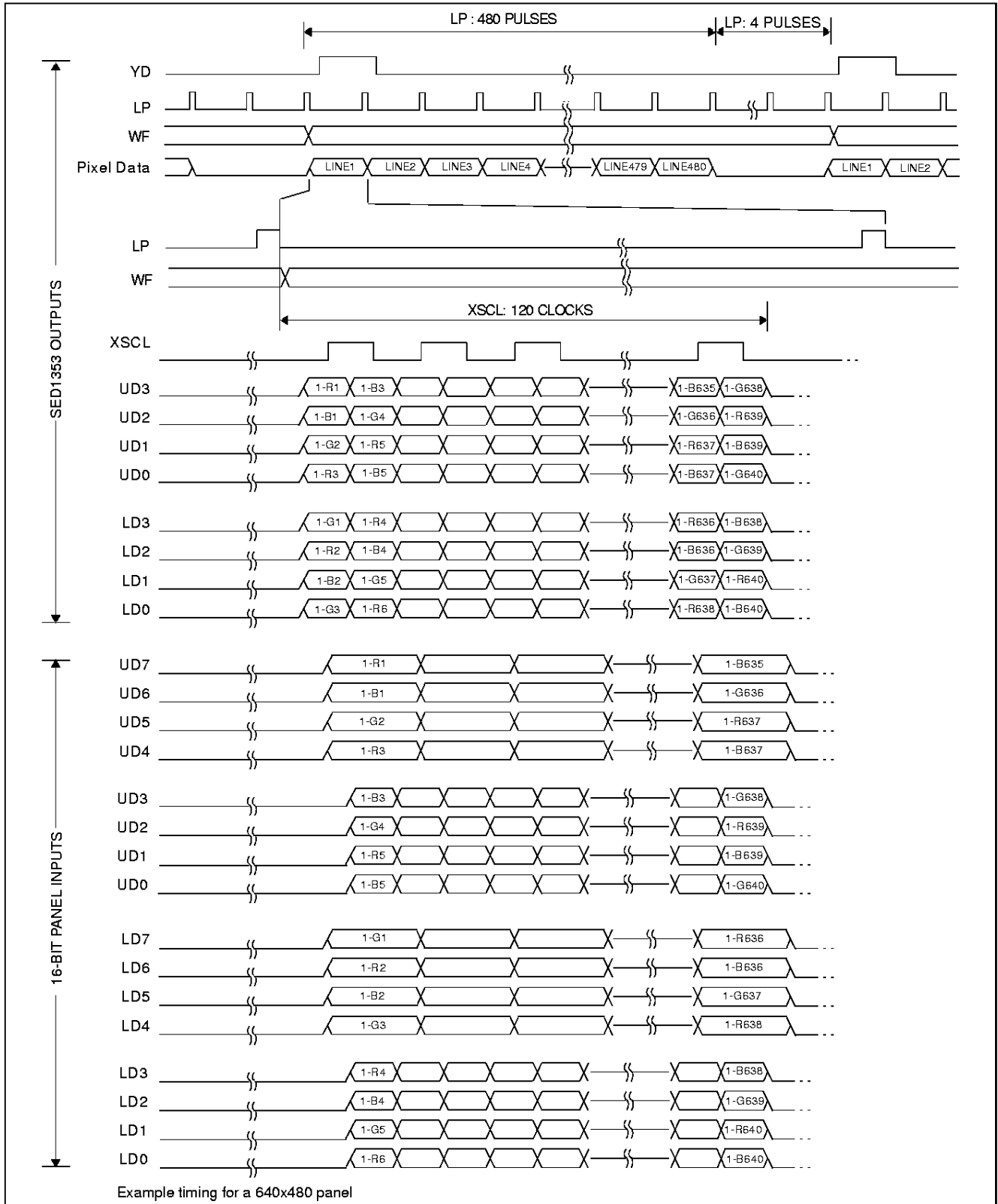
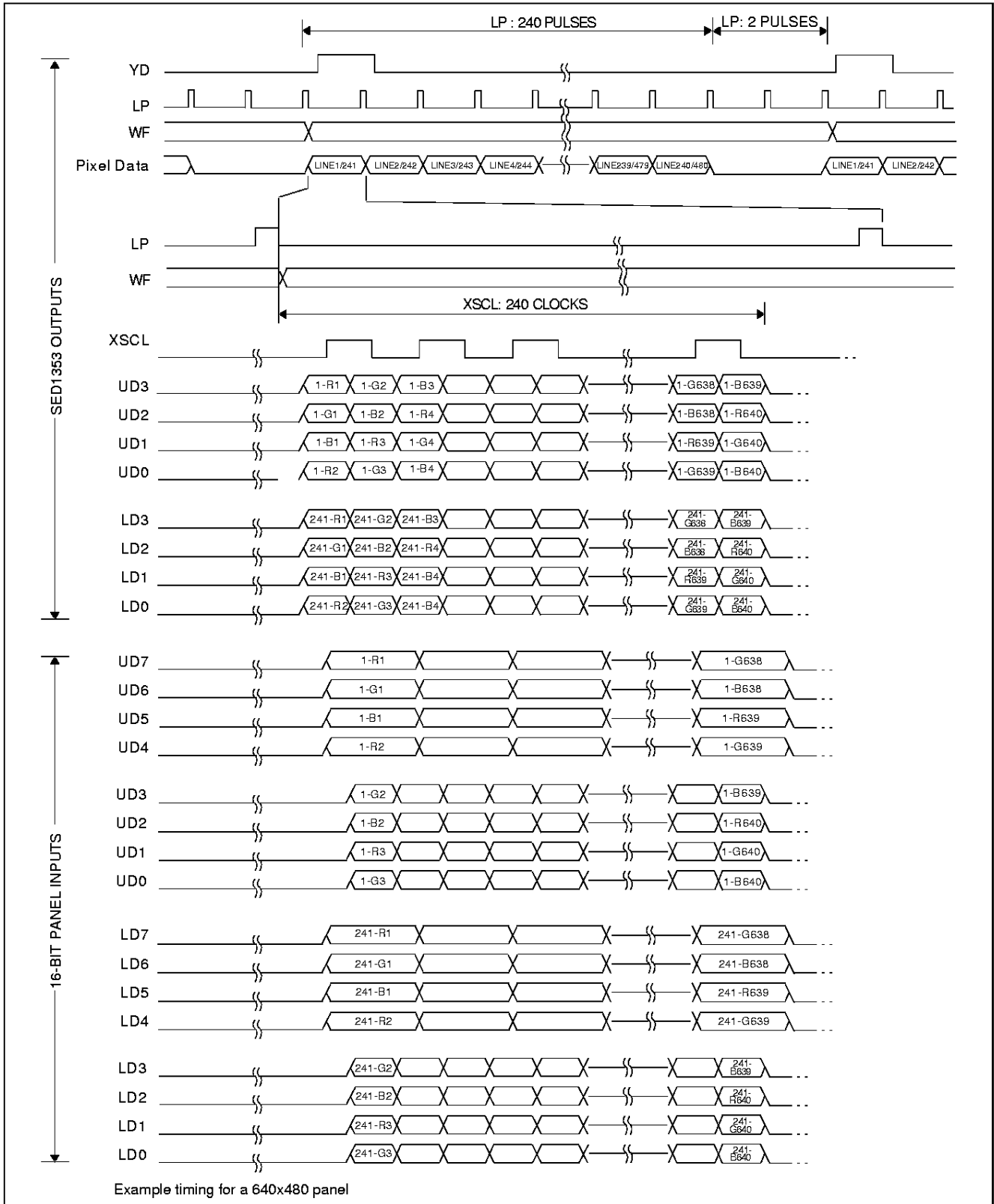

Figure 35: 16-Bit Single Color Panel Timing with External Circuit



Example timing for a 640x480 panel

Figure 36: 16-Bit Dual Color Panel Timing with External Circuit



## 8 HARDWARE REGISTER INTERFACE

The SED1353 is configured and controlled via 16 internal 8-bit registers. There are two ways to map these registers into the system I/O space.

1. Direct-mapping: Absolute I/O address = system address lines AB[3:0] + base I/O mapped address  
(where base I/O address is selected by VD7-VD12, see Table 5-6)

This scheme requires 16 sequential I/O addresses starting from the I/O mapped base address selected by VD7-VD12 (see Table 5-6).

To perform an I/O access:

write data IOW {absolute I/O address}, {data}  
read data IOR {absolute I/O address}

2. Indexing: I/O address = internal index register bits [3:0]

This scheme requires 2 sequential I/O addresses starting from the base address selected by VD4-VD12 (see Table 5-6).

To perform an 8-bit I/O access:

write index IOW {I/O mapped address}, {index} ; write the index of the register to be accessed  
then  
write data IOW {I/O mapped address + 1}, {data} ; write data to the indexed register  
or  
read data IOR {I/O mapped address + 1} ; read the indexed register

To perform a 16-bit I/O access:

write data IOW {I/O mapped address}, {index,data} ; write the index and data of the register to be accessed  
  
read data IOW {I/O mapped address}, {index} ; write to the indexed register  
IOR {I/O mapped address + 1} ; read the indexed register

### 8.1 Register Descriptions

AUX[00] Test Register							
I/O address = 0000b, Read/Write							
Test Mode Enable	Reserved	Test Input Select Bit 2	Test Input Select Bit 1	Test Input Select Bit 0	Test Output Select Bit 2	Test Output Select Bit 1	Test Output Select Bit 0

- bit 7 Test Mode Enable  
When this bit = 0 normal operation is enabled. When this bit = 1 the chip is placed in a special test mode. The test input bits and test output bits (bits 6:0) are used to select various internal test functions.
- bit 6 Reserved  
During normal operation this bit must = 0.
- bits 5-0 Test Mode Input and Output Bits [2:0]  
When bit 7 = 1 these are the Test Input Select Input and Output bits. When bits 6 and 7 = 0 (normal operation) these bits may be used as read/write scratch registers.

<b>AUX[01] Mode Register 0</b>							
I/O address = 0001b, Read/Write.							
DISP	Panel	Mask XSCl	LCDE	Gray Shade / Color	LCD Data Width Bit 0	Memory Interface	RAMS

- bit 7      **DISP**  
This bit selects display on or off. When this bit = 0, Display OFF is selected (LD0-3 and UD0-3 are forced to 0 ). When this bit = 1, Display ON is selected. This bit goes low on RESET.
- bit 6      **Panel**  
This bit selects the LCD panel configuration (single or dual). When this bit = 0, Single LCD panel drive is selected. When this bit = 1 Dual LCD panel drive is selected. This bit goes low on RESET.
- bit 5      **Mask XSCl**  
XSCl is automatically masked during the horizontal non-display period if any of the following criteria is met:
- AUX[0C] value is greater than 00h.
  - Color panel is selected.
  - This bit (AUX[01] bit 5) = 1.
- XSCl will not be masked during the horizontal non-display period if color panel is not selected, AUX[0C] = 00h and this bit = 0.
- bit 4      **LCDE**  
The state of this pin determines the state of output pin 82, LCDENB, and is intended for control of an external LCDBIAS power supply. However, this pin can be used as a general I/O pin if desired. When LCDE = 0, LCDENB is forced low. When LCDE = 1, LCDENB is forced high. LCDE goes low on RESET.
- bit 3      **Gray Shade/Color**  
In gray shade display modes, this bit selects between 16-level or 4-level gray shade display. When this bit = 1, 16 gray shades are displayed (4 bits/pixel). When this bit = 0, 4 gray shades of a possible 16 are displayed (2 bits/pixel).  
In color display modes, this bit selects between 16 color or 4 color display. When this bit = 1, 16 colors are displayed out of a possible of 4096 colors (4 bits/pixel). When this bit = 0, 4 colors are displayed out of a possible of 4096 colors (2 bits/pixel).  
This bit is ignored when either black-and-white (BW) or 256 color mode is selected (AUX[03] bit 2 = 1). This bit goes low on RESET.

*Table 8-1: Gray Shade/Color Mode Selection*

<b>Display Modes</b>	<b>Gray Shade/Color AUX[01] bit 3</b>	<b>BW/ 256 Colors AUX[03] bit 2</b>	<b>Color Mode AUX[03] bit 1</b>
256 Colors	don't care	1	1
16 Colors	1	0	1
4 Colors	0	0	1
16 Grays	1	0	0
4 Grays	0	0	0
BW	don't care	1	0

bit 2 LCD Data Width Bit 0  
Together with LCD Data Width bit 1 (AUX[03] bit 3) this bit selects different display data formats. The following table shows the function of these two bits:

Table 8-2: LCD Data Width

Panel	LCD Data Width Bit 1 AUX[03] bit 3	LCD Data Width Bit 0 AUX[01] bit 2	Function
Monochrome	don't care	0	4-bit LCD data width
Monochrome	don't care	1	8-bit LCD data width
Color	0	0	4-bit LCD data width
Color	0	1	8-bit LCD data width - format 1
Color	1	0	16-bit LCD data width (with external circuit)
Color	1	1	8-bit LCD data width - format 2

For 8-bit dual panels, the data transfer width is forced to 4 bits per panel. This bit goes low on RESET.

bit 1 Memory Interface  
This bit selects between the 8-bit or 16-bit memory interface. When this bit = 0, the 16-bit memory interface is selected. When this bit = 1, the 8-bit memory interface is selected. If 16-bit bus interface (VD0 = 1 on RESET) or 256 color mode (AUX[03] bits 2-1 = 11) is selected, the Memory Interface bit is forced to 0 internally (16-bit). This bit goes low on RESET.

bit 0 RAMS  
This bit configures the display memory address lines for an 8-bit memory interface system. When this bit = 0, addressing for 8Kx8 SRAM on an 8-bit display memory data bus interface is selected. When this bit = 1, addressing for 32Kx8 SRAM on an 8-bit display memory data bus interface is selected. This bit goes low on RESET. This bit is ignored for a 16-bit memory interface.

AUX[02] Line Byte Count Register (LSB)							
I/O address = 0010b, Read/Write.							
Line Byte Count Bit 7	Line Byte Count Bit 6	Line Byte Count Bit 5	Line Byte Count Bit 4	Line Byte Count Bit 3	Line Byte Count Bit 2	Line Byte Count Bit 1	Line Byte Count Bit 0

bits 7-0 Line Byte Count Bits [7:0]  
Along with Line Byte Count Bit 8 (AUX[03] bit 0), this is the number of bytes to be fetched per display line minus 1. To calculate the Line Byte Count use the following formula:

$$LineByteCount(Decimal) = \left( \frac{BitsPerPixel}{MemoryInterfaceWidth} \times HorizontalResolution \right) - 1$$

**Example:**

To calculate the Line Byte Count for 640 horizontal pixels with 16 gray shades (4 bits-per-pixel) and 16-bit memory interface:

$$LineByteCount(Decimal) = \frac{4BitsPerPixel}{16Bits} \times 640 - 1 = 159$$

The following two tables summarize the maximum value of the Line Byte Count Register for different display modes and display memory interface.

*Table 8-3: Maximum Value of Line Byte Count Register - 8-Bit Display Memory Interface*

Display Modes	Maximum Value of Line Byte Count Register	Corresponding Maximum Number of Pixels in One Display Line
black-and-white (BW)	0FFh	256 x 8 = 2048
4-level gray shade / 4 colors	0FFh	256 x 4 = 1024
16-level gray shade / 16 colors	1FFh	512 x 2 = 1024

*Table 8-4: Maximum Value of Line Byte Count Register - 16-Bit Display Memory Interface*

Display Modes	Maximum Value of Line Byte Count Register	Corresponding Maximum Number of Pixels in One Display Line
black-and-white (BW)	0FFh	256 x 16 = 4096
4-level gray shade / 4 colors	0FFh	256 x 8 = 2048
16-level gray shade / 16 colors	0FFh	256 x 4 = 1024
256 colors	1FFh	512 x 2 = 1024

AUX[03] Mode Register 1							
I/O address = 0011b, Read/Write							
PS Bit 1	PS Bit 0	LCD Signal State	LUT Bypass	LCD Data Width Bit 1	BW / 256 colors	Color Mode	Line Byte Count Bit 8

bits 7-6

PS Bits [1:0]

Selects the Power Save Modes as shown in the following table. The PS bits [1:0] go low on RESET.

*Table 8-5: Power Save Mode Selection*

PS1	PS0	Mode Activated
0	0	Normal Operation
0	1	Power Save Mode 1
1	0	Power Save Mode 2
1	1	Reserved

Refer to Power Save Modes on page 77 for a complete Power Save Mode description.

bit 5

LCD Signal State

When this bit = 0, all LCD interface signals are forced low during Power Save modes. When this bit = 1, all LCD interface signals are forced to a high impedance (Hi-Z) state during Power Save modes. This bit goes low on RESET.

bit 4

LUT Bypass

When the LUT Bypass bit = 0, the Look-Up Table is used for display data output in gray shade modes. When this bit = 1, the Look-Up Table is bypassed for display data output in gray shade modes (for power save purposes). There is no effect on changing this bit in BW and color modes. In BW display mode, the Look-Up Table is always bypassed and in color display mode the Look-Up Table cannot be bypassed. The LUT Bypass bit goes low on RESET.

- bit 3      LCD Data Width Bit 1  
Together with LCD Data Width bit 0 (AUX[01] bit 2), this bit selects different display data formats. See Table 8-2, "LCD Data Width," on page 63 for details. This bit goes low on RESET.
- bit 2      BW / 256 colors  
In BW/gray shade display modes, when this bit = 1, black-and-white (BW) mode is selected. When this bit = 0, either 4-level gray shade mode or 16-level gray shade mode is selected.  
In color display modes, when this bit = 1, 256 color mode is selected. When this bit = 0, either 4 color mode or 16 color mode is selected. See Table 8-1, "Gray Shade/Color Mode Selection," on page 62 for details. This bit goes low on RESET.
- bit 1      Color Mode  
When this bit = 1, color display modes are selected. When bit = 0, BW/gray shade display modes are selected. See Table 8-1, "Gray Shade/Color Mode Selection," on page 62 for details. This bit goes low on RESET.
- bit 0      Line Byte Count Bit 8  
This is the MSB of the number of bytes to be fetched per display line minus 1 (see AUX[02]). This bit only has effect when in either 16 colors/gray shades with 8-bit memory interface or 256 colors with 16-bit memory interface.

AUX[04] Total Display Line Count Register (LSB) (Vertical Total)							
I/O address = 0100b, Read/Write.							
Total Disp. Line Count Bit 7	Total Disp. Line Count Bit 6	Total Disp. Line Count Bit 5	Total Disp. Line Count Bit 4	Total Disp. Line Count Bit 3	Total Disp. Line Count Bit 2	Total Disp. Line Count Bit 1	Total Disp. Line Count Bit 0

bits 7-0      Total Display Line Count Bits [7:0]  
These are the 8 LSB of the 10 bit Total Display Line Count and represent the number of scan lines -1, to a maximum value of 3FFh or 1024 scan lines.

In single panel mode:

$$TotalDisplayLineCount = NumberOfDisplayLines - 1$$

In dual panel mode:

$$TotalDisplayLineCount = \left( \frac{NumberOfDisplayLines}{2} \right) - 1$$

Note that the value programmed partially determines the frame period, and hence affects display duty cycle. Bits 8 and 9 are located in the following register (AUX[05]).

<b>AUX[05] Total Display Line Count (MSB) and WF Count Register</b>							
I/O address = 0101b, Read/Write							
WF Count Bit 5	WF Count Bit 4	WF Count Bit 3	WF Count Bit 2	WF Count Bit 1	WF Count Bit 0	Total Disp. Line Count Bit 9	Total Disp. Line Count Bit 8

- bits 7-2      **WF Count Bits [5:0]**  
These bits are used to adjust the WF output signal period. The binary value stored in these bits represents the number of LP pulses -1 between toggles of the WF output. The power up reset value of these bits is 0, which causes the WF output to toggle every frame. When values of 01h to 3Fh are programmed into these bits, the results are WF toggling every 1+n LP pulses, where n is the value programmed. These bits have no effect when 8-bit single color panel format 1 is selected.
- bits 1-0      **Total Display Line Count Bits [9:8]**  
These bits are the two MSB of the Total Display Line Count Register (AUX[04]).

<b>AUX[06] Screen 1 Display Start Address Register (LSB)</b>							
I/O address = 0110b, Read/Write.							
Screen 1 Display Start Addr Bit 7	Screen 1 Display Start Addr Bit 6	Screen 1 Display Start Addr Bit 5	Screen 1 Display Start Addr Bit 4	Screen 1 Display Start Addr Bit 3	Screen 1 Display Start Addr Bit 2	Screen 1 Display Start Addr Bit 1	Screen 1 Display Start Addr Bit 0

<b>AUX[07] Screen 1 Display Start Address Register (MSB)</b>							
I/O address = 0111b, Read/Write.							
Screen 1 Display Start Addr Bit 15	Screen 1 Display Start Addr Bit 14	Screen 1 Display Start Addr Bit 13	Screen 1 Display Start Addr Bit 12	Screen 1 Display Start Addr Bit 11	Screen 1 Display Start Addr Bit 10	Screen 1 Display Start Addr Bit 9	Screen 1 Display Start Addr Bit 8

- AUX[06] bits 7-0      **Screen 1 Display Start Address Bits [15:0]**
- AUX[07] bits 7-0      These 16 bits determine the Screen 1 Display Start Address. In an 8-bit memory configuration these bits set the 16-bit start address (i.e., byte access). In a 16-bit memory configuration these are the 16 most significant bits of a 17-bit start address (i.e., word access).  
  
The Screen 1 Display Start Address is the memory address corresponding to the first displayed pixel (top left corner). In a dual panel configuration, screen 1 refers to the upper half of the display. While in a single panel configuration, screen 1 refers to the first screen of the Split Screen Display feature where two different images (screen 1 and screen 2) can be displayed at the same time on one display.

**Note**  
The absolute address into display memory is determined by the Memory Mapping Address which is set by VD13 - VD15 (see Table 5-6, "Summary of Power On / Reset Options," on page 26).

<b>AUX[08] Screen 2 Display Start Address Register (LSB)</b>							
I/O address = 1000b, Read/Write.							
Screen 2 Display Start Addr Bit 7	Screen 2 Display Start Addr Bit 6	Screen 2 Display Start Addr Bit 5	Screen 2 Display Start Addr Bit 4	Screen 2 Display Start Addr Bit 3	Screen 2 Display Start Addr Bit 2	Screen 2 Display Start Addr Bit 1	Screen 2 Display Start Addr Bit 0

<b>AUX[09] Screen 2 Display Start Address Register (MSB)</b>							
I/O address = 1001b, Read/Write.							
Screen 2 Display Start Addr Bit 15	Screen 2 Display Start Addr Bit 14	Screen 2 Display Start Addr Bit 13	Screen 2 Display Start Addr Bit 12	Screen 2 Display Start Addr Bit 11	Screen 2 Display Start Addr Bit 10	Screen 2 Display Start Addr Bit 9	Screen 2 Display Start Addr Bit 8

AUX[08] bits 7-0 Screen 2 Display Start Address Bits [15:0]

AUX[09] bits 7-0 These 16 bits determine the Screen 2 Display Start Address. In an 8-bit memory configuration these bits set the 16-bit start address (i.e., byte access). In a 16-bit memory configuration these are the 16 most significant bits of a 17-bit start address (i.e., word access).

In a dual panel configuration, screen 2 refers to the lower half of the display. The Screen 2 Display Start Address is the memory address corresponding to the first displayed pixel in the first line of the lower half of the display. If screen 2 is started right after screen 1, the screen 2 display start address can be calculated with the following formula:

$$Screen2DisplayStartAddress(hex) = \frac{(ImageHorizontalResolution) \times (ImageVerticalResolution) \times (BytesPerPixel)}{2 \times \left( \frac{MemoryInterfaceWidth}{8} \right)} + Screen1DisplayStartAddress$$

In a single panel configuration, screen 2 refers to the second screen of the Split Screen Display Feature where two different images (screen 1 and screen 2) can be displayed at the same time on one display. The Screen 2 Display Start Address is the memory address corresponding to the first pixel of the second image stored in display memory. To display screen 2 refer to AUX[0A] Screen 1 Display Line Count Register (LSB) on page 68.

<b>AUX[0A] Screen 1 Display Line Count Register (LSB)</b>							
I/O address = 1010b, Read/Write.							
Screen 1 Display Line Count Bit 7	Screen 1 Display Line Count Bit 6	Screen 1 Display Line Count Bit 5	Screen 1 Display Line Count Bit 4	Screen 1 Display Line Count Bit 3	Screen 1 Display Line Count Bit 2	Screen 1 Display Line Count Bit 1	Screen 1 Display Line Count Bit 0

<b>AUX[0B] Screen 1 Display Line Count Register (MSB)</b>							
I/O address = 1011b, Read/Write.							
n/a	n/a	n/a	n/a	n/a	n/a	Screen 1 Display Line Count Bit 9	Screen 1 Display Line Count Bit 8

AUX[0A] bits 7-0 Screen 1 Display Line Count Bits [9:0]

AUX[0B] bits 1-0 These bits are the eight LSB of a 10-bit value used to determine the number of lines displayed for screen 1. The remaining lines will automatically display from the screen 2 display start address. The 10-bit value programmed is the number of display lines -1.

This register is used to enable the split screen display feature (single panel only) where two different images can be displayed at the same time on one display.

For example; AUX[0A] = 20h for a 320x240 display system. The display will display 20h+1 = 33 lines on the upper part of the screen as dictated by the screen 1 display start address registers (AUX[06] and AUX[07]), and 240 - 33 = 207 lines will be displayed on the lower part of the screen as dictated by the screen 2 display start address registers (AUX[08] and AUX[09]).

Two different images can be displayed when using a dual panel configuration by changing the screen 2 display start address. However, by using this method screen 2 is limited to the lower half of the display.

This register is ignored in dual panel mode.



<b>AUX[0C] Horizontal Non-Display Period</b>							
I/O address = 1100b, Read/Write.							
Horizontal Non-Display Period Bit 7	Horizontal Non-Display Period Bit 6	Horizontal Non-Display Period Bit 5	Horizontal Non-Display Period Bit 4	Horizontal Non-Display Period Bit 3	Horizontal Non-Display Period Bit 2	Horizontal Non-Display Period Bit 1	Horizontal Non-Display Period Bit 0

bits 7-0

**Horizontal Non-Display Period Bits [7:0]**

These bits are used to adjust the horizontal non-display period (See “Frame Rate Calculation” on page 84 for details). When these bits = 0, the fixed default non-display period (DHNDP) is used. Otherwise, a non-display period of DHNDP & AUX[0C] + 1 is used. The unit of AUX[0C] is the same as the unit of Line Byte Count Register, i.e. number of bytes to be fetched. See description of AUX[02] and Section 9.3 on page 84 for details.

For example, if an additional 32 pixels wide of horizontal non-display period is desired in a 4 grays (2 bits-per-pixel) and 16-bit display memory interface system:  $AUX[0C] = [32 / (16 / 2)] - 1 = 3$ .

Note that the value programmed determines the period of one line, and hence affects the frame period.

<b>AUX[0D] Address Pitch Adjustment Register</b>							
I/O address = 1101b, Read/Write.							
Addr Pitch Adjustment Bit 7	Addr Pitch Adjustment Bit 6	Addr Pitch Adjustment Bit 5	Addr Pitch Adjustment Bit 4	Addr Pitch Adjustment Bit 3	Addr Pitch Adjustment Bit 2	Addr Pitch Adjustment Bit 1	Addr Pitch Adjustment Bit 0

bits 7-0

**Address Pitch Adjustment Bits [7:0]**

This register controls the virtual display by setting the numerical difference between the last address of a display line, and the first address in the following line.

If the Address Pitch Adjustment is not equal to zero, then a virtual screen is formed. The size of the virtual screen is only limited by the available display memory. The actual display output is a window that is part of the whole image stored in the display memory. For example, with 128K of display memory, a 640x400 16-gray image can be stored. If the output display size is 320x240, then the whole image can be seen by changing display starting addresses through AUX[06] and [07], and AUX[08] and [09]. Note that a virtual screen can be produced on either a single or dual panel.

In 8-bit memory interface, if the Address Pitch Adjustment is not equal to zero, a virtual screen with a line length of (Line Byte Count +AUX[0D]) bytes is created, with the display reflecting the contents of a window (Line Byte Count+1) bytes wide. The position of the window on the virtual screen is determined by AUX[06] and [07], and AUX[08] and [09].

In 16-bit memory interface, if the Address Pitch Adjustment is not equal to zero, then a virtual screen with a line length of 2x(Line Byte Count +AUX[0D]) bytes is created, with the display reflecting the contents of a window 2x(Line Byte Count+1) bytes wide. The position of the window on the virtual screen is determined by AUX[06] and [07], and AUX[08] and [09].

<b>AUX[0E] Look-Up Table Address Register</b>							
I/O address = 1110b, Read/Write							
Green Bank Bit 1	Green Bank Bit 0	ID Bit / RGB Index Bit 1	ID Bit / RGB Index Bit 0	Palette Address Bit 3	Palette Address Bit 2	Palette Address Bit 1	Palette Address Bit 0

The SED1353 has three internal 16 position, 4-bit wide Look-Up Tables (palettes). The 4-bit value programmed into each table position determines the output gray shade / color weighting of display data. These tables are bypassed in black-and-white (BW) display mode.

These three 16 position Look-Up Tables can be arranged in many different configurations to accommodate all the gray shade / color display modes.

Refer to Look-Up Table Architecture on page 72 for formats.

bits 7-6

Green Bank Bits [1:0]

In 4-level gray / color display modes (2-bits/pixel), the 16 position Green palette is arranged into four, 4 position "banks". These two bits control which bank is currently selected. These bits have no effect in 16-level gray / color display modes (4-bits/pixel).

In 256 color display modes (8-bit/pixel), the 16 position Green palette is arranged into two, 8 position "banks" for the display of "green" colors. Only bit 0 of these two bits controls which bank is currently selected.

bits 5-4

ID Bit / RGB Index Bits [1:0]

These bits have dual purpose;

*ID Bits:* After power on or hardware reset, these bits can be read to identify the SED1353. These same bits are used to identify the pin compatible SED1352 and would only be used in system implementations where common software is being used. As these bits are R/W they must be read before being written in order to be used as ID bits.

Table 8-6: ID Bit Usage

	Chip	Aux[0E]	
		bit 5	bit 4
Power On or RESET	SED1353	0	0
	F352	0	1
	SED1352F0B/F1B/D0B	1	0
	SED1352	1	1

*RGB Index bits [1:0]:* These bits are also used to provide access to the three internal Look-Up Tables (RGB).

Table 8-7: Look-Up Table Access

Aux[0E]		Look-Up Table Access
bit 5	bit 4	
0	0	Auto-increment (see Note 1)
0	1	Red palette R/W access
1	0	Green palette R/W access
1	1	Blue palette R/W access

**Note**

When auto-increment is selected, an internal pointer will default to the Red palette on power on reset. Each read/write access to Aux[0F] will increment the counter to point to the next palette in order (RGB). Whenever the Look-Up Table Address register Aux[0E] is written, the RGB Index will reset the pointer to the Red palette. This provides a efficient method for sequential writing of RGB data.

bits 3-0            Palette Address Bits [3:0]  
                      These 4 bits provide a pointer into the 16 position Look-Up Table currently selected for CPU R/W access.

**Note**

The Look-Up Table configuration (e.g. 1/2/4 banks) does not affect the R/W access from the CPU as all 16 positions can be accessed sequentially.

<b>AUX[0F] Look-Up Table Data Register</b>							
I/O address = 1111b, Read/Write.							
Red Bank Bit 1	Red Bank Bit 0	Blue Bank Bit 1	Blue Bank Bit 0	Palette Data Bit 3	Palette Data Bit 2	Palette Data Bit 1	Palette Data Bit 0

bit 7-6            Red Bank Bits [1:0]  
                      In 4-level color display modes, the 16 position Red palette is arranged into four, 4 position “banks”. These two bits control which bank is currently selected.  
                      In 256 color display modes, the 16 position, Red palette is arranged into two, 8 position “banks” for the display of “red” colors. Only bit 0 of these two bits controls which bank is currently selected.  
                      These bits have no effect in all gray shade or 16-color display modes.

bit 5-4            Blue Bank Bits [1:0]  
                      In both the 4 and 256 color display modes, the 16 position Blue palette is arranged into four 4 position “banks” for the display of “blue” colors. These two bits control which bank is currently selected.  
                      These bits have no effect in all gray shade display modes or 16 color display modes.

bits 3-0            Palette Data Bits [3:0]  
                      These 4-bits are the gray shade / color values used for display data output. They are programmed into the 4-bit Look-Up Table (palettes) positions pointed to by Palette Address bits [3:0] and RGB Index bit[1:0] (if in color display modes).

For example; in a 16-level gray shade display mode, a data value of 0001b (4-bits / pixel) will point to Look-Up Table position one and display the 4-bit gray shade corresponding to the value programmed into that location.

## 8.2 Look-Up Table Architecture

Table 8-8: Look-Up Table Configurations

Display Mode	4-bit wide Palette		
	RED	GREEN	BLUE
Black & White			
4-level gray		4 banks of 4	
16-level gray		1 bank of 16	
4 color	4 banks of 4	4 banks of 4	4 banks of 4
16 color	1 bank of 16	1 bank of 16	1 bank of 16
256 color	2 banks of 8	2 banks of 8	4 banks of 4

Indicates the palette is not used for that display mode

### 8.2.1 Gray Shade Display Modes

#### 4-Level Gray Shade Mode

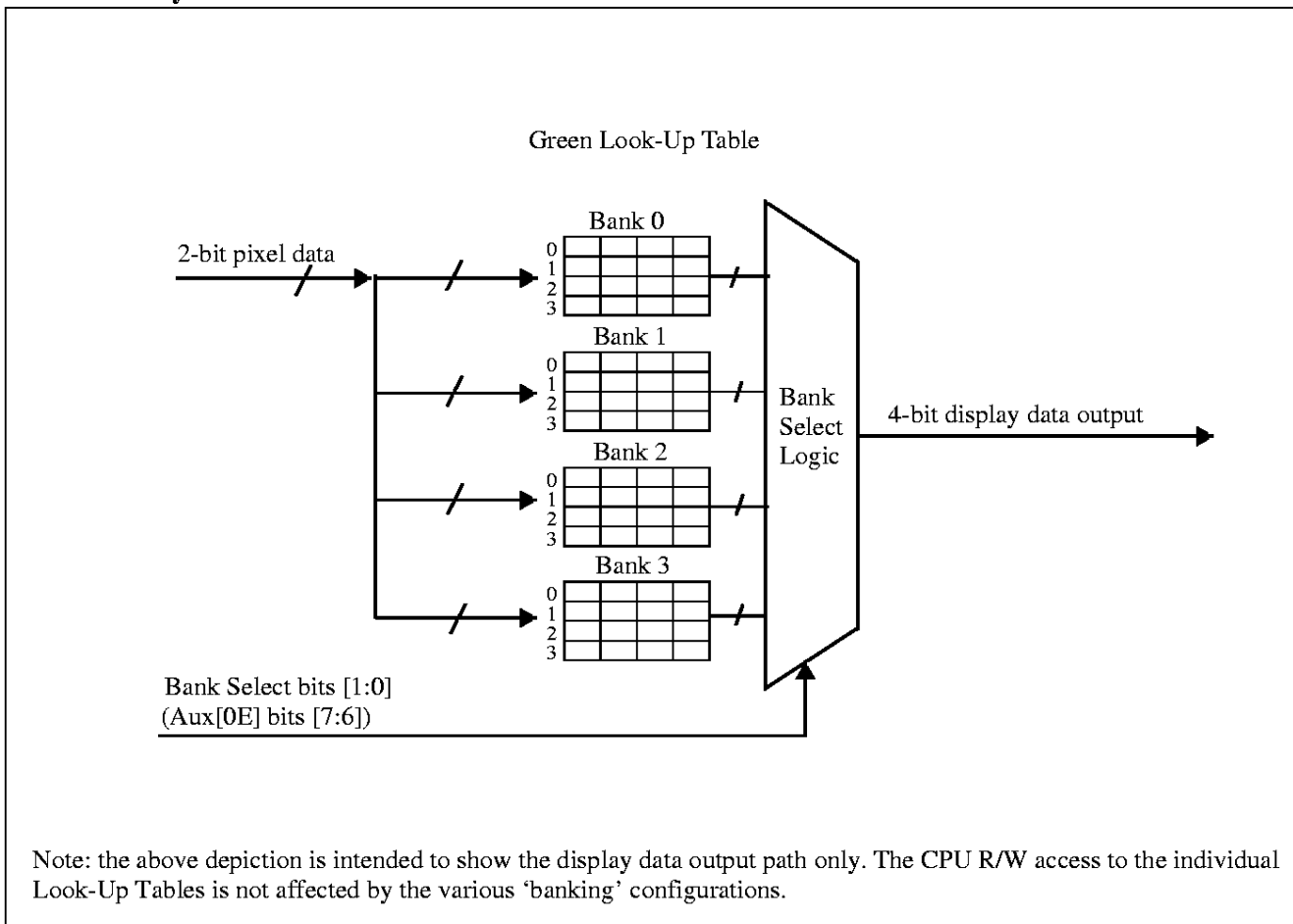

Figure 37: 4-Level Gray-Shade Mode Look-Up Table Architecture

### 16-Level Gray Shade Mode

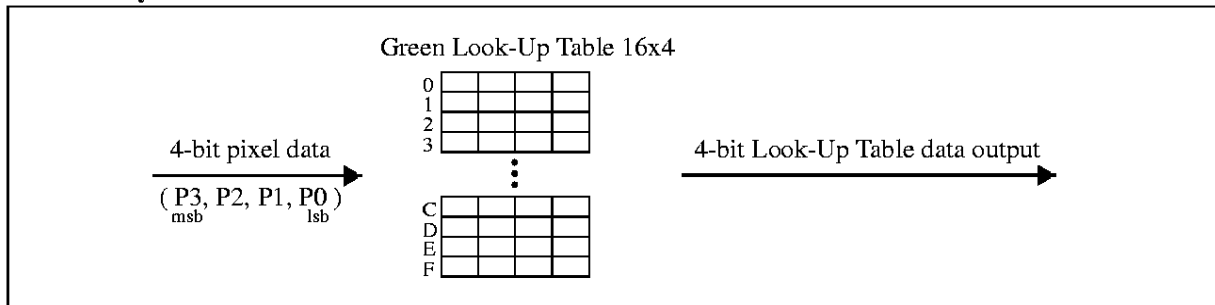

Figure 38: 16-Level Gray-Shade Mode Look-Up Table Architecture

**Note**

The Look-Up Table is bypassed in black-and-white display mode

## 8.2.2 Color Display Modes

### 4-Level Color Mode

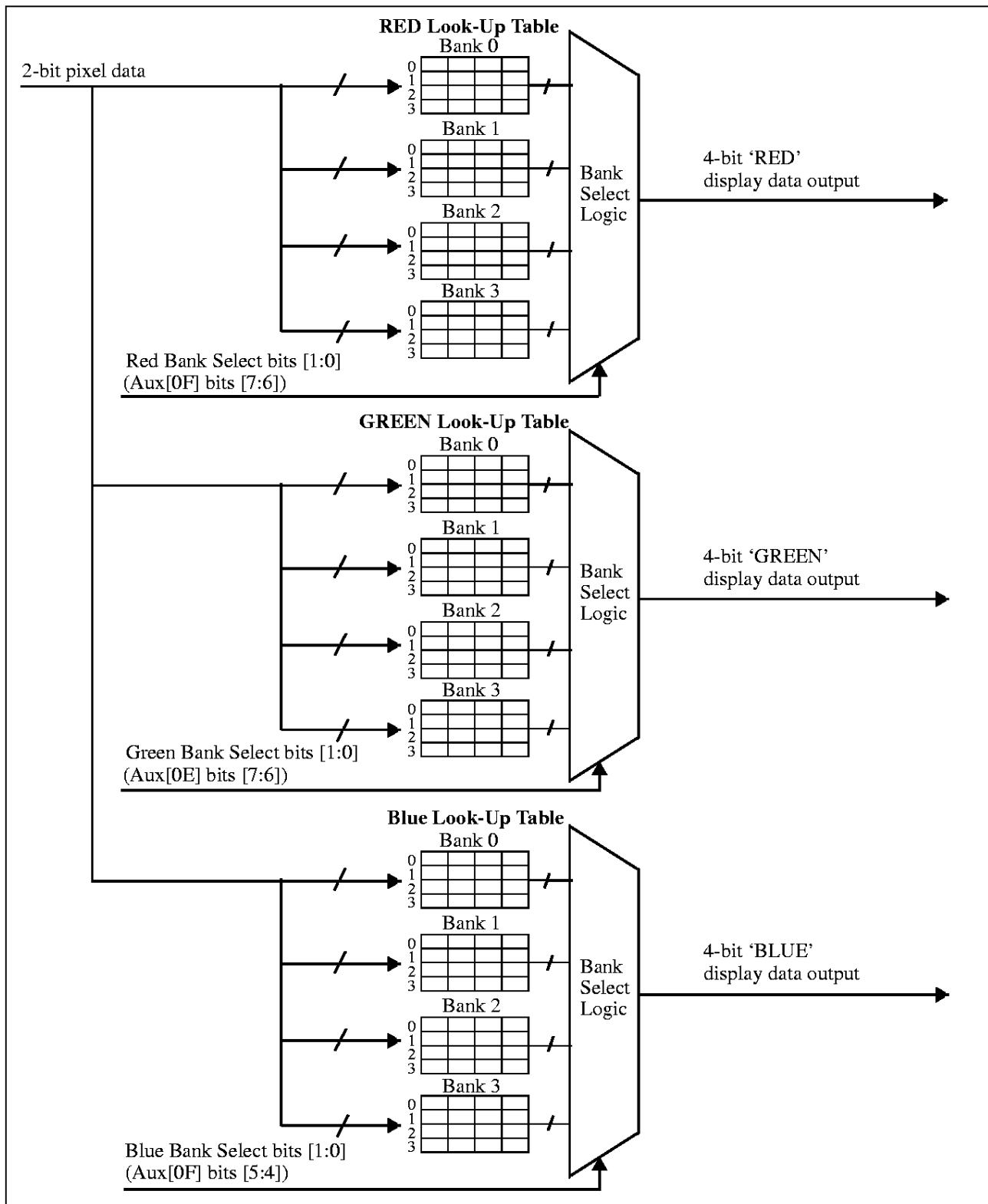

Figure 39: 4-Level Color Mode Look-Up Table Architecture

16-Level Color Mode

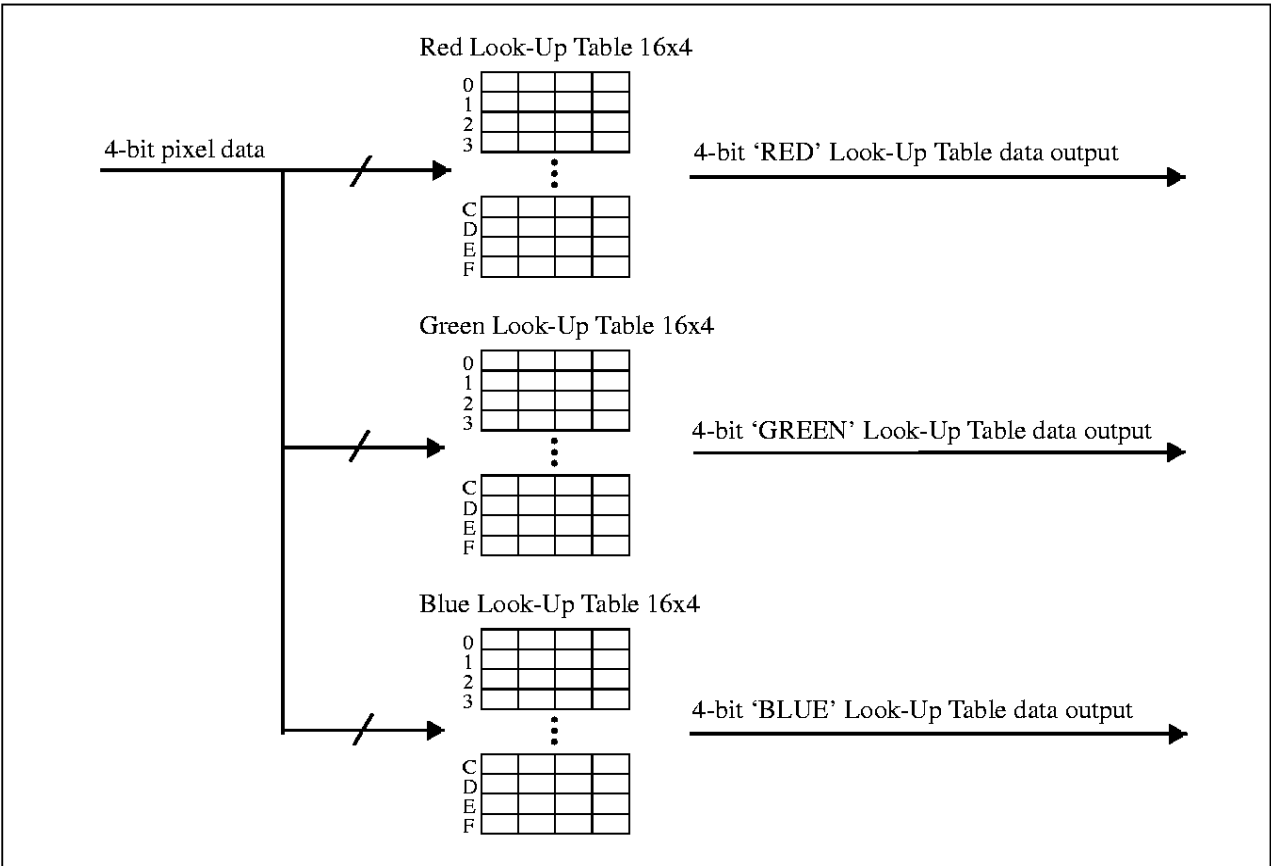

Figure 40: 16-Level Color Mode Look-Up Table Architecture

256-Level Color Mode

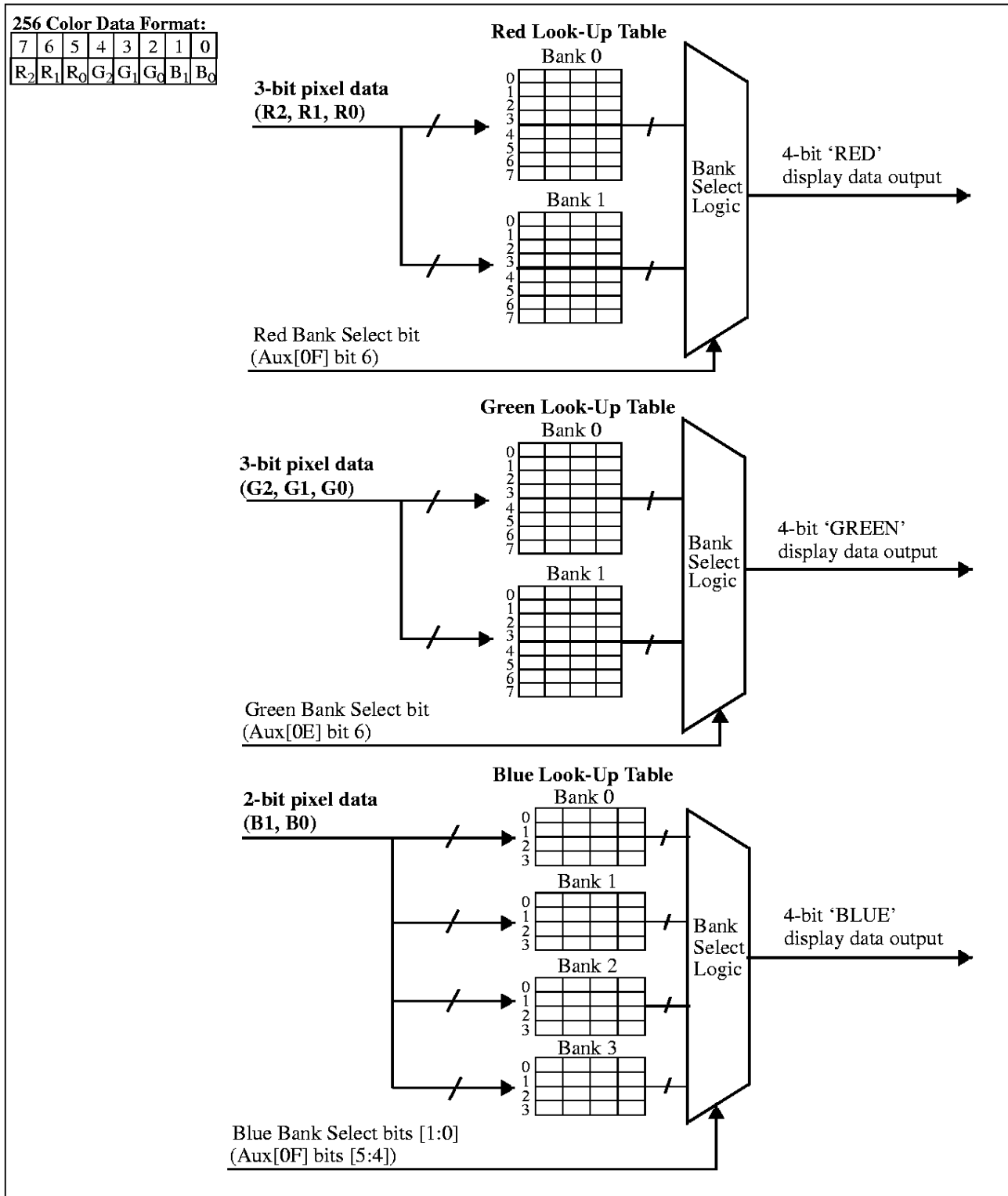

Figure 41: 256-Level Color Mode Look-Up Table Architecture



## 8.3 Power Save Modes

Two software-controlled Power Save Modes have been incorporated into the SED1353 to accommodate the important need for power reduction in the hand-held devices market. These modes can be enabled by setting the two Power Save bits (AUX[03] bits 7:6).

The various settings are:

*Table 8-9: Power Save Mode Selection*

Bit 5	Bit 4	Mode Activated
0	0	Normal Operation
0	1	Power Save Mode 1
1	0	Power Save Mode 2
1	1	Reserved

### 8.3.1 Power Save Mode 1

Power Save Mode 1 has two states. Initially when set, the SED1353 enters State 1. If no valid memory cycle is detected within 1, 2, or 4 clocks (input clock frequency dependent), the chip will enter State 2. The number of clocks of inactivity before entering State 2 is dependent on the display memory interface and the number of Gray shades.

#### State 1

- I/O read/write of all registers allowed
- Memory read/write allowed
- LCD outputs are either forced low (AUX[03] bit 5=0), or high impedance (AUX[03] bit 5=1)

#### State 2

The same as State 1 as well as:

- Master clock for display memory access is disabled

Once a valid memory read/write cycle is detected, the SED1353 returns to State 1 where the MPU access is serviced. The transition from going from State 2 to State 1 requires 1, 2, or 4 clocks (as described above).

### 8.3.2 Power Save Mode 2

- I/O read/write of all registers allowed
- Memory read/write is disabled
- Master clock for display memory access is disabled
- LCD outputs are either forced low (AUX[03] bit 5=0), or high impedance (AUX[03] bit 5=1)
- Internal oscillator is disabled.

### 8.3.3 Power Save Mode Function Summary

Table 8-10: Power Save Mode Function Summary

Function	Power Save Mode (PSM)			
	Normal (Active)	PSM1		PSM2
		State 1	State 2	
Display Active?	Yes	No	No	No
I/O Access Possible?	Yes	Yes	Yes	Yes
Memory Access Possible?	Yes	Yes	No	No
Sequence Controller Running?	Yes	No	No	No
Internal Oscillator Disabled?	No	No	No	Yes

### 8.3.4 Pin States in Power Save Modes

Table 8-11: Pin States in Power Save Modes

Pin	Pin State			
	Normal (Active)	PSM1		PSM2
		State 1	State 2	
UD[3:0], LD[3:0], LP, XSCL, YD, WF/XSCL2 (Note 1)	Active	High Impedance	High Impedance	High Impedance
UD[3:0], LD[3:0], LP, XSCL, YD, WF/XSCL2 (Note 2)	Active	Forced Low	Forced Low	Forced Low
AB[19:0], DB[15:0]	Active	Active	Active	Active
IOR#, IOW#	Active	Active	Active	Active
MEMR#, MEMW#	Active	Active	Active	Active
RESET	Active	Active	Active	Active

**Note**

1. Internal Register AUX[03], bit 5 = 1
2. Internal Register AUX[03], bit 5 = 0

## 9 DISPLAY MEMORY INTERFACE

### 9.1 SRAM Configurations Supported

#### 9.1.1 8-Bit Mode

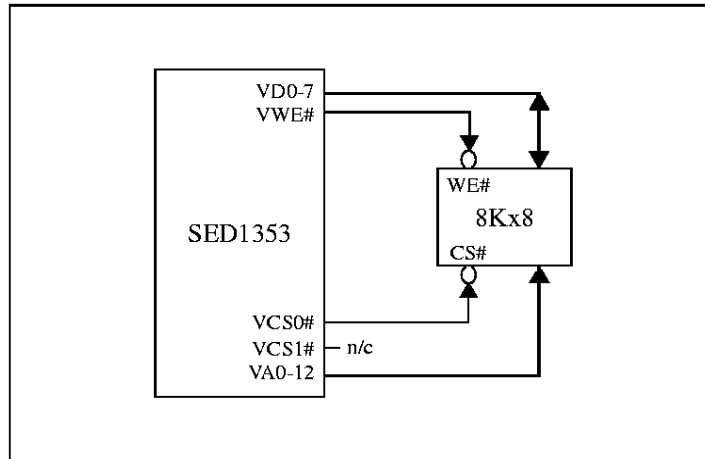

Figure 42: 8-Bit Mode - 8K bytes SRAM

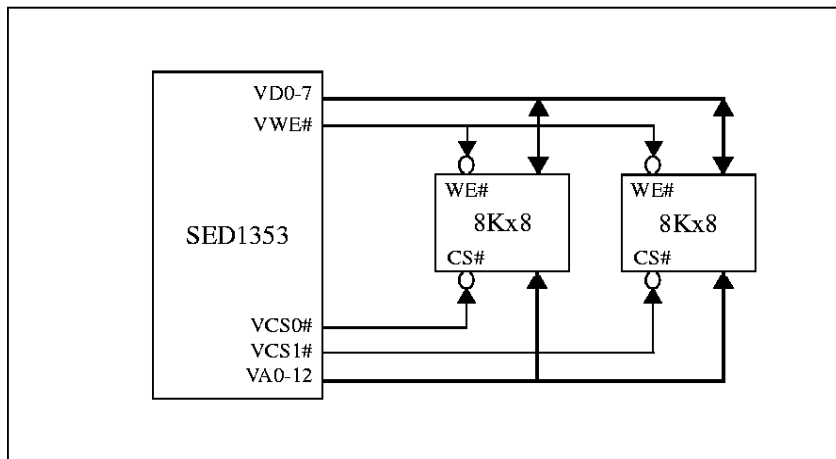

Figure 43: 8-Bit Mode - 16K bytes SRAM  
(Requires AUX[01] bit 0 = 0)

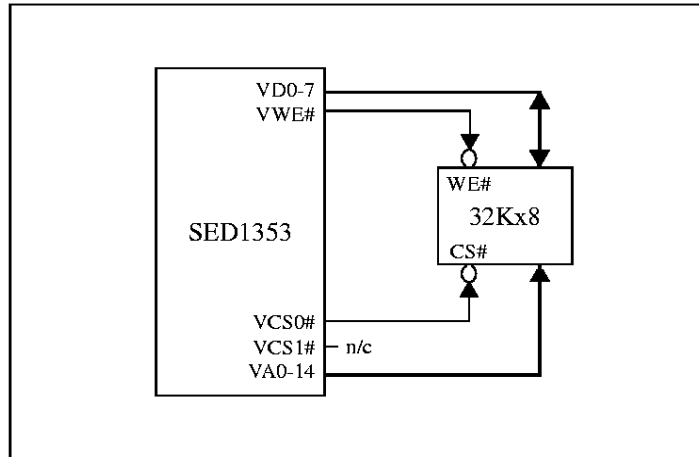

Figure 44: 8-Bit Mode - 32K bytes SRAM  
(Requires AUX[01] bit 0 = 1)

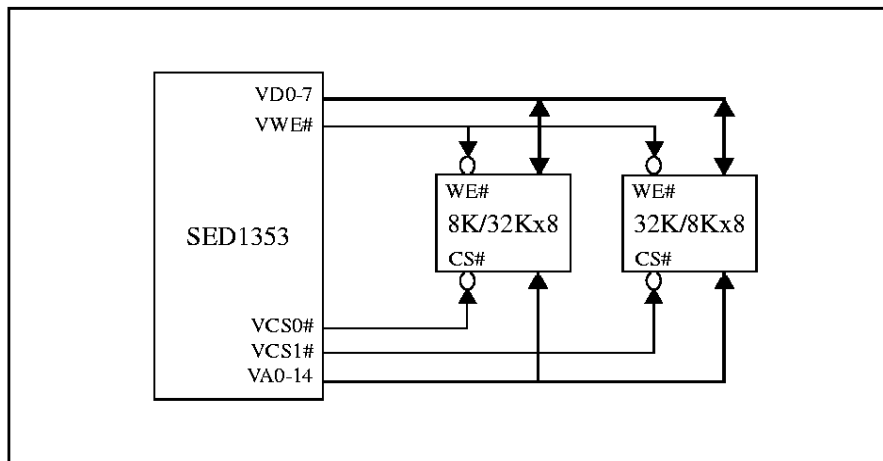

Figure 45: 8-Bit Mode - 40K bytes SRAM  
[either (8Kx8 + 32Kx8) requiring AUX[01] bit 0 = 0 or (32Kx8 + 8Kx8) requiring AUX[01] bit 0 = 1]

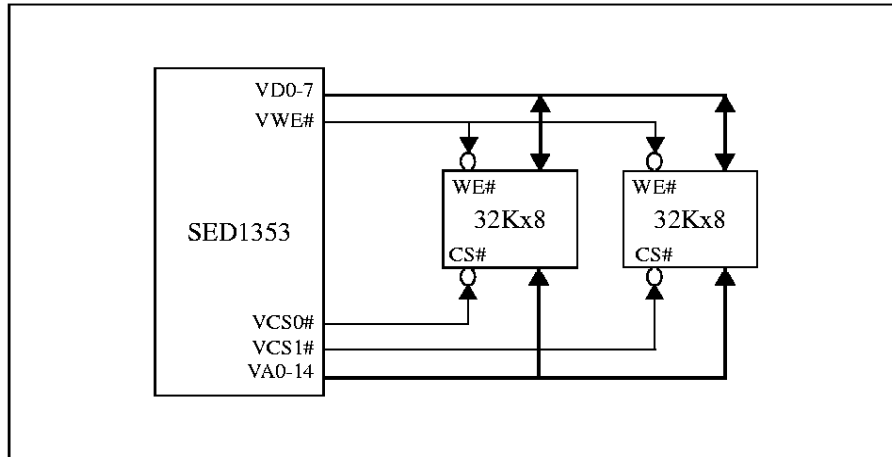

Figure 46: 8-Bit Mode - 64K bytes SRAM  
 (Requires AUX[01] bit 0 = 1)

9.1.2 16-bit Mode

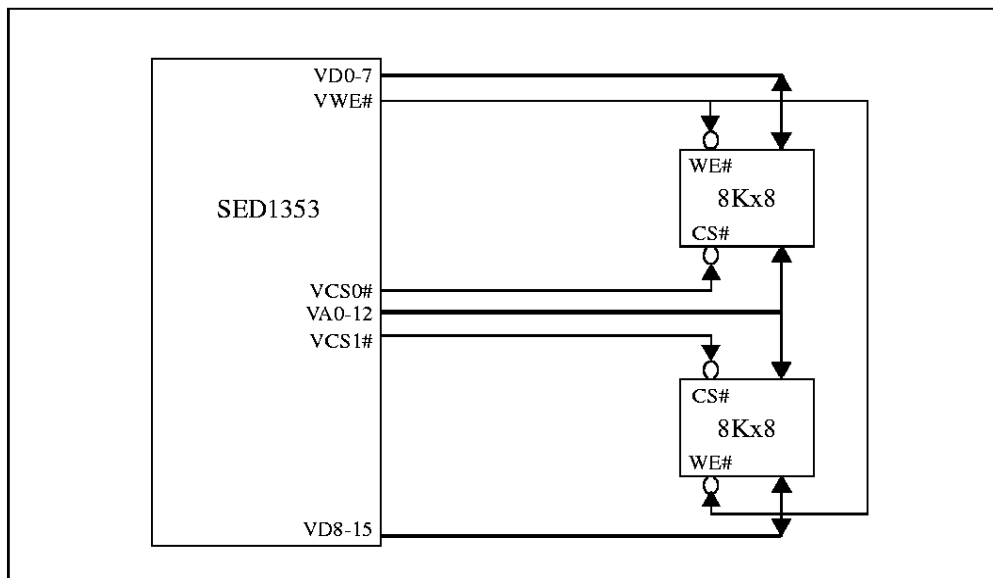

Figure 47: 16-Bit Mode - 16K bytes SRAM

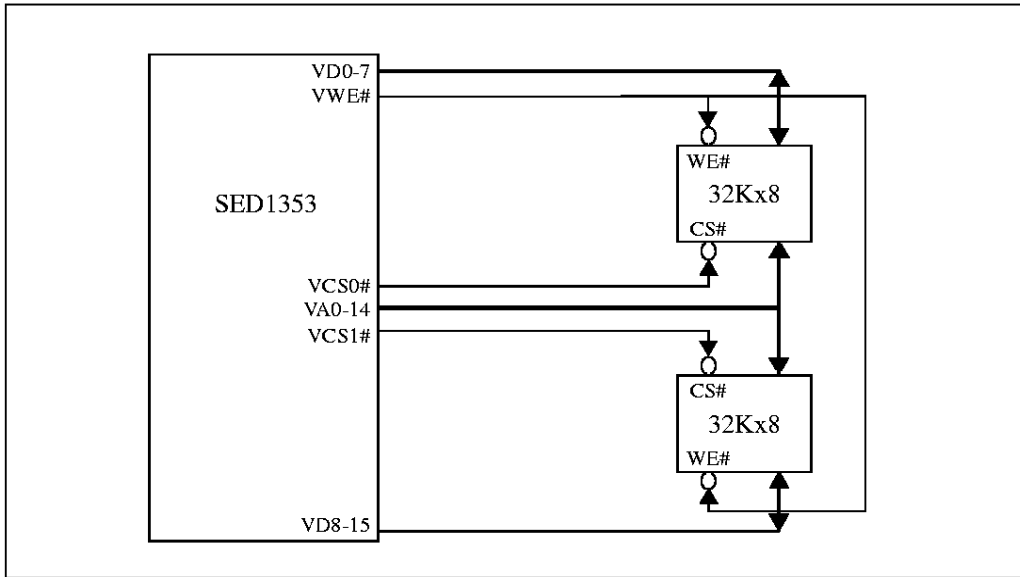

Figure 48: 16-Bit Mode - 64K bytes SRAM

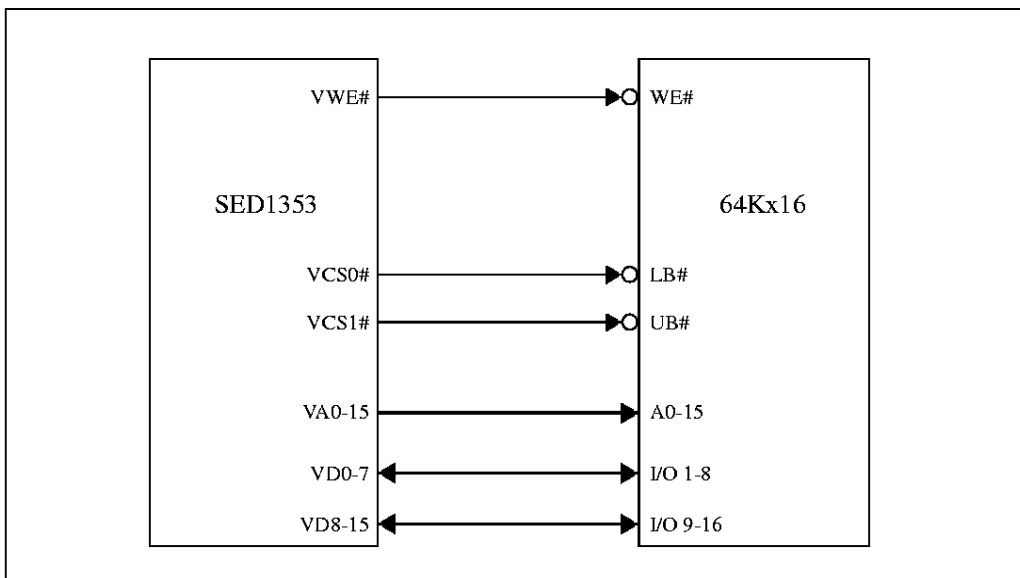

Figure 49: 16-Bit Mode - 128K bytes SRAM

## 9.2 SRAM Access Time

### 9.2.1 8-bit Display Memory Interface:

*Table 9-1: 8-Bit Display Memory Interface SRAM Access Time*

Display Mode	3V/3.3V	5V
16-level gray shades / 16-level colors	Access time $\leq 1 / f_{OSC} - 40ns$	Access time $\leq 1 / f_{OSC} - 25ns$
4-level gray shades / 4-level colors	Access time $\leq 2 / f_{OSC} - 40ns$	Access time $\leq 2 / f_{OSC} - 25ns$
Black-and-White (BW)	Access time $\leq 2 / f_{OSC} - 40ns$	Access time $\leq 2 / f_{OSC} - 25ns$

### 9.2.2 16-bit Display Memory Interface:

*Table 9-2: 16-Bit Display Memory Interface SRAM Access Time*

Display Mode	3V/3.3V	5V
256-level colors	Access time $\leq 1 / f_{OSC} - 40ns$	Access time $\leq 1 / f_{OSC} - 25ns$
16-level gray shades / 16-level colors	Access time $\leq 2 / f_{OSC} - 40ns$	Access time $\leq 2 / f_{OSC} - 25ns$
4-level gray shades / 4-level colors	Access time $\leq 4 / f_{OSC} - 40ns$	Access time $\leq 4 / f_{OSC} - 25ns$
Black-and-White (BW)	Access time $\leq 4 / f_{OSC} - 40ns$	Access time $\leq 4 / f_{OSC} - 25ns$

## 9.3 Frame Rate Calculation

### 9.3.1 For single panel

Black-and-White (BW) Display Mode:

$$FrameRate = \frac{2 \times f_{osc}}{(HorizontalPixels + PHNDP + DHNDP) \times (VerticalLines + 4)}$$

All Other Display Modes:

$$FrameRate = \frac{f_{osc}}{(HorizontalPixels + PHNDP + DHNDP) \times (VerticalLines + 4)}$$

### 9.3.2 For dual panel

Black-and-White (BW) Display Mode:

$$FrameRate = \frac{2 \times f_{osc}}{(HorizontalPixels + PHNDP + DHNDP) \times 2 \times \left( \frac{VerticalLines}{2} + 2 \right)}$$

All Other Display Modes:

$$FrameRate = \frac{f_{osc}}{(HorizontalPixels + PHNDP + DHNDP) \times 2 \times \left( \frac{VerticalLines}{2} + 2 \right)}$$

Where DHNDP is Default Horizontal Non-Display Period in term of pixels :

DHNDP = 16 pixels per panel in gray shade display modes, and

DHNDP = 32 pixels per panel in BW display mode and in color display modes.

Where PHNDP is Programmable Horizontal Non-Display Period in term of pixels :

PHNDP = 0 pixels when AUX[0C] = 0, and

PHNDP =  $\frac{(AUX[0C] + 1) \times (MemoryInterfaceWidth)}{(BitsPerPixel)}$  pixels when AUX[0C] not equal to zero.



## 9.4 Memory Size Calculation

$$\text{Memory Size (bytes)} = \frac{(\text{HorizontalPixels}) \times (\text{VerticalLines}) \times (\text{BitsPerPixel})}{8}$$

Example : For a 640x480, 4 gray shades (2 bits-per-pixel) system :

$$\text{Memory Size (bytes)} = \frac{(640) \times (480) \times (2)}{8} = 76800\text{bytes} = 75\text{Kbyte}$$

## 9.5 Memory Size Requirement

The following tables summarize the preceding information (formulae).

Input clock ( $f_{OSC}$ ) is limited by SRAM access time depending on the display mode and display memory interface that is being used. As a result, different resolutions will have different input clock and memory requirements for a particular frame rate. Tables 9-3 through 9-5 summarize the minimum memory size and access time requirements for various resolutions at a particular input clock along with the corresponding frame rates.

Table 9-3: Memory Size Requirement: Number of Horizontal Pixels = 640

		Number of Horizontal Pixels = 640												Example			
		Black-and-White (BW) (1 bit-per-pixel)			4 Grays / 4 Colors (2 bits-per-pixel)			16 Grays / 16 Colors (4 bits-per-pixel)			256 Colors (8 bits-per-pixel)						
Condition		AUX[0C] = AUX[02]			AUX[0C] = 0			AUX[0C] = 0			AUX[0C] = 0						
Number of Vertical Lines	Display Mode	Display Memory Interface	Size		Access Time		Size		Access Time		Size		Access Time		Input Clock ( $f_{OSC}$ )	Frame Rate	
			(KB)		3V/3.3V	5V	(KB)		3V/3.3V	5V	(KB)		3V/3.3V	5V		BW / Gray	Color
480	8-bit	37.5	40 ns	55 ns	75	(2)	(2)	150	(1)	(1)	300	(1)	(1)	24 MHz	76 Hz	74 Hz	
	16-bit		125 ns	140 ns		125 ns	140 ns		60 ns	75 ns		125 ns	140 ns				60 ns
	400	8-bit	32	60 ns	75 ns	62.5	60 ns	75 ns	125	(2)	(2)	250	(1)	(1)	20 MHz	75 Hz	74 Hz
	16-bit	160 ns		175 ns	160 ns		175 ns	85 ns		100 ns	85 ns		100 ns				
	320	8-bit	25	85 ns	100 ns	50	85 ns	100 ns	100	(2)	(2)	200	(1)	(1)	16 MHz	75 Hz	73 Hz
	16-bit	210 ns		225 ns	210 ns		225 ns	125 ns		140 ns	125 ns		140 ns				
256	8-bit	20	125 ns	140 ns	40	125 ns	140 ns	80	(2)	(2)	160	(1)	(1)	12 MHz	70 Hz	69 Hz	
16-bit	290 ns		305 ns	290 ns		305 ns	125 ns		140 ns	125 ns		140 ns					
240	8-bit	19	125 ns	140 ns	37.5	125 ns	140 ns	75	(2)	(2)	150	(1)	(1)	12 MHz	75 Hz	73 Hz	
16-bit	290 ns		305 ns	290 ns		305 ns	160 ns		175 ns	160 ns		175 ns					
200	8-bit	16	160 ns	175 ns	32	160 ns	175 ns	62.5	60 ns	75 ns	125	(2)(3)	(2)(3)	10 MHz	75 Hz	73 Hz	
16-bit	360 ns		375 ns	360 ns		375 ns	60 ns		75 ns	60 ns		75 ns					

- (1) Memory more than 128KB cannot be supported by SED1353.
- (2) Memory more than 64KB can only be supported through 16-bit display memory interface.
- (3) 256 color mode must use 16-bit display memory interface.

\* KB = K byte = 1024 bytes

Table 9-4: Memory Size Requirement: Number of Horizontal Pixels = 480

		Number of Horizontal Pixels = 480																			
		Display Mode	Black-and-White (BW) (1 bit-per-pixel)			4 Grays / 4 Colors (2 bits-per-pixel)			16 Grays / 16 Colors (4 bits-per-pixel)			256 Colors (8 bits-per-pixel)			Example						
		Condition	AUX[0C] = AUX[02]			AUX[0C] = 0			AUX[0C] = 0			AUX[0C] = 0									
		Display Memory Interface	Size (KB)		Access Time		Size (KB)		Access Time		Size (KB)		Access Time		Size (KB)		Access Time		Input Clock (f <sub>OSC</sub> )	Frame Rate	
			3V/3.3V	5V	3V/3.3V	5V	3V/3.3V	5V	3V/3.3V	5V	3V/3.3V	5V	3V/3.3V	5V	3V/3.3V	5V	BW / Gray	Color			
Number of Vertical Lines	480	8-bit 16-bit	29	70 ns 180 ns	85 ns 195 ns	57	70 ns 180 ns	85 ns 195 ns	113	(2) 70 ns	(2) 85 ns	225	(1)	(1)	18 MHz	75 Hz	73 Hz				
	400	8-bit 16-bit	23.5	100 ns 240 ns	115 ns 255 ns	47	100 ns 240 ns	115 ns 255 ns	94	(2) 100 ns	(2) 115 ns	188	(1)	(1)	14 MHz	70 Hz	68 Hz				
	320	8-bit 16-bit	19	125 ns 290 ns	140 ns 305 ns	37.5	125 ns 290 ns	140 ns 305 ns	75	(2) 125 ns	(2) 140 ns	150	(1)	(1)	12 MHz	75 Hz	72 Hz				
	256	8-bit 16-bit	15	160 ns 360 ns	175 ns 375 ns	30	160 ns 360 ns	175 ns 375 ns	60	60 ns 160 ns	75 ns 175 ns	120	(2)(3) 60 ns	(2)(3) 75 ns	10 MHz	77 Hz	75 Hz				
	240	8-bit 16-bit	14.5	210 ns 460 ns	225 ns 475 ns	29	210 ns 460 ns	225 ns 475 ns	57	85 ns 210 ns	100 ns 225 ns	113	(2)(3) 85 ns	(2)(3) 100 ns	8 MHz	66 Hz	64 Hz				
	200	8-bit 16-bit	12	210 ns 460 ns	225 ns 475 ns	23.5	210 ns 460 ns	225 ns 475 ns	47	85 ns 210 ns	100 ns 225 ns	94	(2)(3) 85 ns	(2)(3) 100 ns	8 MHz	79 Hz	77 Hz				

Table 9-5: Memory Size Requirement: Number of Horizontal Pixels = 320

		Number of Horizontal Pixels = 320																			
		Display Mode	Black-and-White (BW) (1 bit-per-pixel)			4 Grays / 4 Colors (2 bits-per-pixel)			16 Grays / 16 Colors (4 bits-per-pixel)			256 Colors (8 bits-per-pixel)			Example						
		Condition	AUX[0C] = AUX[02]			AUX[0C] = 0			AUX[0C] = 0			AUX[0C] = 0									
		Display Memory Interface	Size (KB)		Access Time		Size (KB)		Access Time		Size (KB)		Access Time		Size (KB)		Access Time		Input Clock (f <sub>OSC</sub> )	Frame Rate	
			3V/3.3V	5V	3V/3.3V	5V	3V/3.3V	5V	3V/3.3V	5V	3V/3.3V	5V	3V/3.3V	5V	3V/3.3V	5V	BW / Gray	Color			
Number of Vertical Lines	480	8-bit 16-bit	19	125 ns 290 ns	140 ns 305 ns	37.5	125 ns 290 ns	140 ns 305 ns	75	(2) 125 ns	(2) 140 ns	150	(1)	(1)	12 MHz	74 Hz	70 Hz				
	400	8-bit 16-bit	16	160 ns 360 ns	175 ns 375 ns	32	160 ns 360 ns	175 ns 375 ns	62.5	60 ns 160 ns	75 ns 175 ns	125	(2)(3) 60 ns	(2)(3) 75 ns	10 MHz	74 Hz	70 Hz				
	320	8-bit 16-bit	12.5	210 ns 460 ns	225 ns 475 ns	25	210 ns 460 ns	225 ns 475 ns	50	85 ns 210 ns	100 ns 225 ns	100	(2)(3) 85 ns	(2)(3) 100 ns	8 MHz	73 Hz	70 Hz				
	256	8-bit 16-bit	10	290 ns 625 ns	305 ns 640 ns	20	290 ns 625 ns	305 ns 635 ns	40	125 ns 290 ns	140 ns 305 ns	80	(2)(3) 125 ns	(2)(3) 140 ns	6 MHz	69 Hz	66 Hz				
	240	8-bit 16-bit	9.5	290 ns 625 ns	305 ns 640 ns	19	290 ns 625 ns	305 ns 640 ns	37.5	125 ns 290 ns	140 ns 305 ns	75	(2)(3) 125 ns	(2)(3) 140 ns	6 MHz	73 Hz	70 Hz				
	200	8-bit 16-bit	8	360 ns 760 ns	375 ns 775 ns	16	360 ns 760 ns	375 ns 775 ns	32	160 ns 360 ns	175 ns 375 ns	62.5	(2)(3) 160 ns	(2)(3) 175 ns	5 MHz	73 Hz	70 Hz				

- (1) Memory more than 128KB cannot be supported by SED1353.
  - (2) Memory more than 64KB can only be supported through 16-bit display memory interface.
  - (3) 256 color mode must use 16-bit display memory interface.
- \* KB = K byte = 1024 bytes

## 10 MECHANICAL DATA

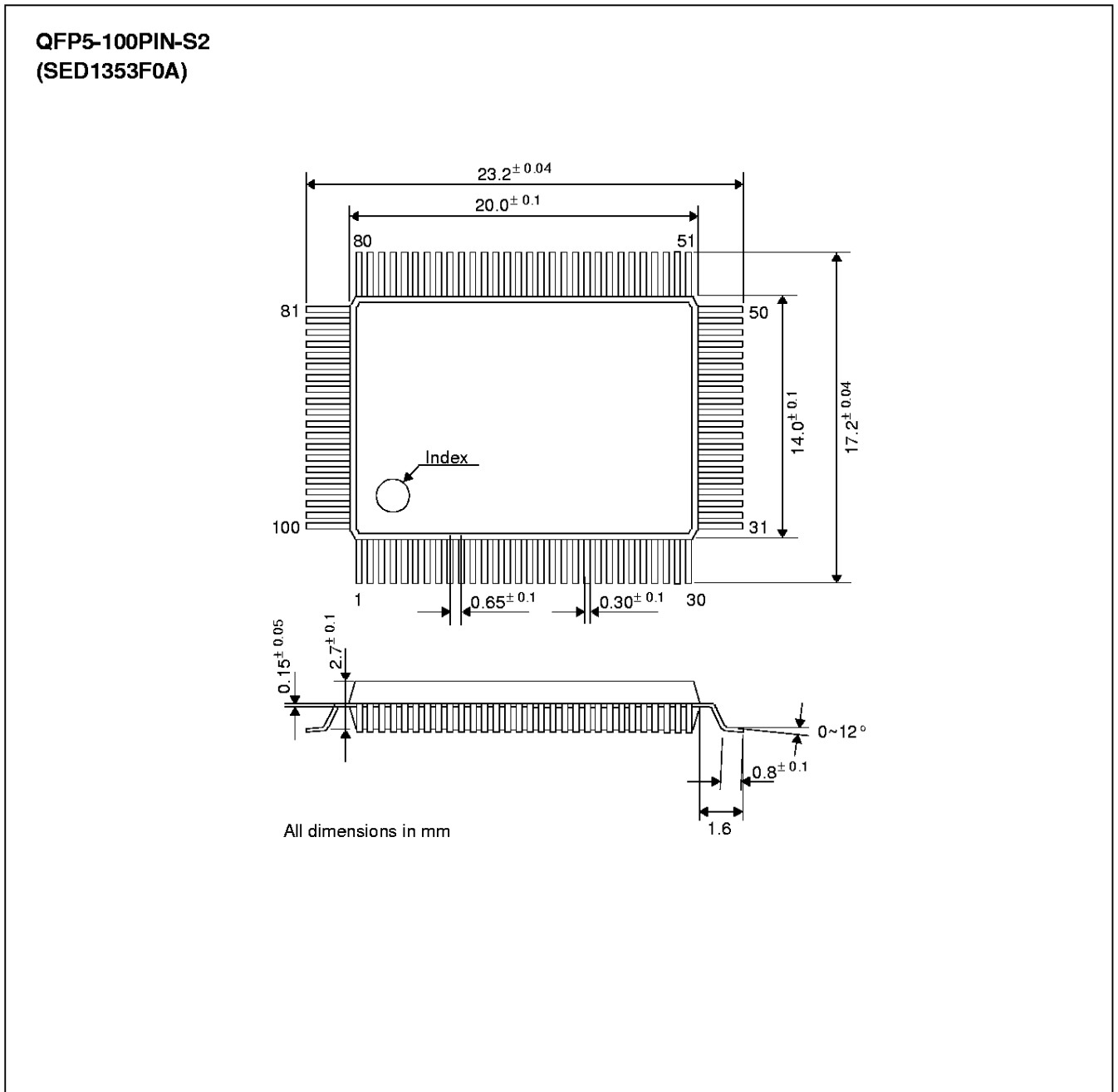

Figure 50: Mechanical Drawing QFP5-100-S2 (SED 1353F0A)





## **SED1353 Dot Matrix Graphics LCD Controller**

# **Programming Notes and Examples**

**Drawing Office No. X18A-G-002-03**

Copyright © 1996, 1997 S-MOS Systems Inc. All rights reserved.

This document, and any text derived, extracted or transmitted from it, is the sole property of S-MOS Systems Inc. and may not be used, copied, transmitted or otherwise made available to any other person, unless specifically allowed under license agreement with S-MOS Systems Inc. If furnished under a license, this document may be used and copied only in accordance with the terms of such license, and with the inclusion of this copyright notice. No title or ownership of the technology herein is transferred.

The information in this document is subject to change without notice and should not be construed as a commitment by S-MOS Systems Inc. This document does not necessarily describe any current planned or future product by S-MOS Systems Inc., nor does it represent any commitment to implement any such product.

**THIS PAGE LEFT BLANK**

## TABLE OF CONTENTS

<b>1</b>	<b>INTRODUCTION</b>	<b>9</b>
<b>2</b>	<b>INITIALIZING THE SED1353</b>	<b>10</b>
<b>3</b>	<b>GRAY SHADES / COLORS AND LOOK-UP TABLES</b>	<b>18</b>
3.1	Pixels	18
3.1.1	Memory Organization for One Bit Pixel (Black-and-White)	18
3.1.2	Memory Organization for Two Bit Pixels (4 Colors/Gray Shades)	18
3.1.3	Memory Organization for Four Bit Pixels (16 Colors/Gray Shades)	19
3.1.4	Memory Organization for Eight Bit Pixels (256 Colors)	19
3.2	Look-Up Table (LUT)	20
3.2.1	LUT Registers	20
3.2.2	Look-Up Table Description	22
3.2.3	Black-and-White (One Bit/Pixel)	25
3.2.4	Four Gray Shades (Two Bits/Pixel in Monochrome Mode)	26
3.2.5	Four Colors (Two Bits/Pixel in Color Mode)	28
3.2.6	Sixteen Gray Shades (Four Bits/Pixel in Monochrome Mode)	30
3.2.7	Sixteen Colors (Four Bits/Pixel in Color Mode)	31
3.2.8	256 Colors (Eight Bits/Pixel in Color Mode)	32
<b>4</b>	<b>DISPLAY MEMORY MODELS</b>	<b>34</b>
4.1	Registers	34
4.2	Description	36
4.2.1	SDU1353B0C Evaluation Board Display Memory	36
4.2.2	Display Start Address Registers	37
4.3	Common Display Memory Requirements for LCD Panel Sizes:	38
<b>5</b>	<b>ADVANCED TECHNIQUES</b>	<b>40</b>
5.1	Virtual Displays	40
5.1.1	Registers	40
5.1.2	Description	41
5.2	Bitmaps and Text Displays	42
5.3	Mapping of Registers	43
5.3.1	Indexed Mapping	43
5.3.2	Direct Mapping	44
5.4	Split Screen	45
5.4.1	Description	45
5.4.2	Single Panel LCD	46
5.4.3	Dual Panel LCD	48
5.5	Panning and Scrolling	52
5.5.1	Initialization	52
5.5.2	Panning Right and Left	52
5.5.3	Scrolling Up and Down	53

5.6 Power Saving . . . . . 54

    5.6.1 Registers . . . . . 54

    5.6.2 Power Save Modes . . . . . 54

**6 IDENTIFYING THE SED1353 . . . . . .56**

**7 PROGRAMMING THE SED1353 . . . . . .57**

    7.1 Main Loop Code . . . . . 58

    7.2 Initialization Code . . . . . 60

    7.3 Advanced Functions . . . . . 66

**8 GLOSSARY . . . . . .88**



## LIST OF TABLES

Table 3-1: Number Of Bits As Related To Colors . . . . .	.18
Table 3-2: ID Bit Usage . . . . .	.20
Table 3-3: Look-Up Table Access. . . . .	.21
Table 3-4: Look-Up Table Configurations . . . . .	.22
Table 3-5: Sed1353F0A Color Look-up Table For 256 Color Mode . . . . .	.23
Table 3-6: SED1353 Black-To-White Look-Up Table . . . . .	.24
Table 3-7: SED1353 Inverted Look-Up Table (White-To-Black) . . . . .	.25
Table 3-8: SED1353 Black-To-White Look-up Table For 4 Gray Shades . . . . .	.26
Table 3-9: SED1353 Low To High Intensity Color Look-Up Table For 4 Colors . . . . .	.28
Table 3-10: Simulation Of First 16 Entries Of Standard VGA Palette . . . . .	.31
Table 3-11: Examples Of 256 Pixel Colors Using Linear LUT. . . . .	.32
Table 4-1: Memory Size Requirements . . . . .	.38
Table 5-1: Smallest Number Of Pixels For Panning . . . . .	.52
Table 5-2: Power Save Mode Selection . . . . .	.54
Table 5-3: Power Save Mode Selection . . . . .	.54
Table 5-4: Power Save Mode Function Summary. . . . .	.55
Table 6-1: ID Bit Usage . . . . .	.56

**THIS PAGE LEFT BLANK**

## LIST OF FIGURES

Figure 1: Pixel Storage For 1 Bit (Black-and-White) In One Byte Of Display Memory . . . . .	18
Figure 2: Pixel Storage For 2 Bits (4 Colors/Gray Shades) In One Byte Of Display Memory . . . . .	18
Figure 3: Pixel Storage For 4 Bits (16 Colors/gray Shades) In One Byte Of Display Memory . . . . .	19
Figure 4: Pixel Storage For 8 Bits (256 Colors) In One Byte Of Display Memory. . . . .	19
Figure 5: 4-Level Gray-Shade Mode Look-Up Table Architecture. . . . .	27
Figure 6: 4-Level Color Mode Look-Up Table Architecture . . . . .	29
Figure 7: 16-Level Gray-Shade Mode Look-Up Table Architecture . . . . .	30
Figure 8: 16-Level Color Mode Look-Up Table Architecture . . . . .	31
Figure 9: 256-Level Color Mode Look-Up Table Architecture. . . . .	33
Figure 10: Memory Map Example For 320 x 240 LCD Panel With 4 Colors/Gray Shades . . . . .	38
Figure 11: Memory Map Example For 320 x 240 LCD Panel With 256 Colors . . . . .	39
Figure 12: Memory Map Example For 640 x 200 LCD Panel With 16 Colors/Gray Shades. . . . .	39
Figure 13: Moving A Viewport Inside A Virtual Display. . . . .	41
Figure 14: Font For The Message "TEXT" . . . . .	42
Figure 15: Display Memory Contents For Message "Text" In 256 Color Mode . . . . .	43
Figure 16: Memory Map For Split Screen. . . . .	46
Figure 17: 320 x 240 Single Panel For Split Screen. . . . .	48
Figure 18: 640 x 480 Dual Panel For Split Screen . . . . .	49
Figure 19: Memory Map For A Dual Panel Showing A Single Image . . . . .	51
Figure 20: Display For 1353DEMO.EXE. . . . .	57

**THIS PAGE LEFT BLANK**

## 1 INTRODUCTION

The purpose of this guide is to demonstrate how to program the SED1353 LCD controller, with reference made to the SDU1353B0C evaluation board. The first half of this guide presents the basic concepts of LCD controllers.

The second half of this guide presents programming examples which are combined in a simple menu-driven program. Most of the program is written in the 'C' programming language, with some parts written in 8086 assembly.

## 2 INITIALIZING THE SED1353

This section presents two examples to show how to initialize the SED1353 registers and write a pixel to the display. Code to initialize the SED1353 is provided in Section 7.2, “Initialization Code” on page 60.

The following examples describe values written to registers.

- A “panel specific” value is one required for the given type of panel. Such a value must never change after initialization of all registers.
- An “implementation specific” value is one required for the hardware implementation of the SED1353. Such a value must never change after initialization of all registers. Refer to the *SED1353F0x Hardware Functional Specification* and *SDU1353B0C Evaluation Board User’s Manual* for more information on hardware implementation issues.
- An “application specific” value is one that can be changed by the program after initialization of all registers.

**Example 1: Initialize the registers for a 256 color 320 x 240 single panel LCD with 128k of display memory. Afterwards write one pixel to the top left corner of the display.**

Program SED1353 Registers in the following order with the data supplied:

AUX Register	Data (in Binary)	Notes	See Also
AUX[00h]	0000 0000	<ul style="list-style-type: none"> <li>• bits 7 and 6 must be zero</li> </ul>	
AUX[01h]	0010 1001	<ul style="list-style-type: none"> <li>• b7 = display off (application specific; the recommended procedure is to turn this bit off during register initialization and afterwards turn this bit on)</li> <li>• b6 = single panel (panel specific)</li> <li>• b5 = XSCL is masked (panel specific)</li> <li>• b4 = LCDE = LCDENB pin = set to disable specific power supply design (for SDU1353B0C, set bit to 0 to disable power supply) (application specific; the recommended procedure is to disable the power supply during register initialization and afterwards enable the power supply)</li> <li>• b3 = N/A for 256 colors (application specific)</li> <li>• b2 = 4 bit LCD data width when combined with AUX[03] bit 3 (panel specific)</li> <li>• b1 = 16 bit Memory Interface (implementation specific)</li> <li>• b0 = RAMS ignored (implementation specific)</li> </ul>	
AUX[02h]	1001 1111	<ul style="list-style-type: none"> <li>• bits 7-0 = bits 7-0 of Line Byte Count</li> <li>• bit 8 of Line Byte Count is bit 0 of AUX[03h]</li> </ul>	see Note A at end of Table for calculation
AUX[03h]	0000 0110	<ul style="list-style-type: none"> <li>• bits 7-6 = Power Save Mode 0 (application specific - for normal operation set to 00b)</li> <li>• bit 5 = LCD interface signals forced low during Power Save (implementation and panel specific)</li> <li>• bit 4 = no LUT bypass (application specific)</li> <li>• bit 3 = 4 bit LCD data width when combined with AUX[01] bit 2 (panel specific)</li> <li>• bit 2 = 256 color mode (application specific)</li> <li>• bit 1 = color panel attached (panel specific)</li> <li>• bit 0 = bit 8 of Line Byte Count (panel specific, see AUX[02h])</li> </ul>	see Section 5.6, “Power Saving” on page 54
AUX[04h]	1110 1111	<ul style="list-style-type: none"> <li>• bits 7-0 = bits 7-0 of Total Display Line Count</li> <li>• bits 9-8 of Total Display Line Count in bits 1-0 of AUX[05h]</li> </ul>	see Note B and C at end of Table for calculation

AUX Register	Data (in Binary)	Notes	See Also
AUX[05h]	0000 0000	<ul style="list-style-type: none"> <li>bits 7-2: 0 = WF output toggles every frame (panel specific)</li> <li>bits 1-0 = bits 9-8 of Total Display Line Count (panel specific, see AUX[04h])</li> </ul>	
AUX[06h] AUX[07h]	0000 0000 0000 0000	<ul style="list-style-type: none"> <li>bits 15-0 of Screen 1 Display Start Address - normally Screen 1 Start Address = 0000h (application and panel specific)</li> <li>bits 7-0 are in AUX[06h] and bits 15-8 are in AUX[07h]</li> <li>when 0000h, Screen 1 Display Start Address is located at D000:0000h, bank 0, on the SDU1353B0C</li> </ul>	see Section 4.2.1, "SDU1353B0C Evaluation Board Display Memory" on page 36 and Section 4.1, "Registers" on page 34
AUX[08h] AUX[09h]	0000 0000 0000 0000	<ul style="list-style-type: none"> <li>bits 15-0 of Screen 2 Display Start Address - normally Screen 2 Start Address = 0000h (application and panel specific)</li> <li>bits 7-0 are in AUX[08h] and bits 15-8 are in AUX[09h]</li> <li>when 0000h, Screen 1 Display Start Address is located at D000:0000h, bank 0, on the SDU1353B0C</li> </ul>	see Section 4.2.1, "SDU1353B0C Evaluation Board Display Memory" on page 36 and Section 4.1, "Registers" on page 34
AUX[0Ah]	1110 1111	<ul style="list-style-type: none"> <li>bits 7-0 = bits 7-0 of Screen 1 Display Line Count</li> <li>bits 9-8 of Screen 1 Display Line Count in bits 1-0 of AUX[0Bh]</li> <li>Screen 1 Display Line Count is typically the same as Total Display Line Count (AUX[0Ah] = AUX[04h], bits 1-0 of AUX[0Bh] = bits 1-0 of AUX[05h])</li> </ul>	see Section 5.4, "Split Screen" on page 45
AUX[0Bh]	0000 0000	<ul style="list-style-type: none"> <li>bits 7-2 = don't care; recommend clearing bits</li> <li>bits 1-0 = bits 9-8 of Screen 1 Display Line Count (application specific, see AUX[0Ah])</li> </ul>	
AUX[0Ch]	0000 0000	normally programmed to 00h (panel specific) <ul style="list-style-type: none"> <li>bits 7-0 = use fixed default non-display period</li> </ul>	
AUX[0Dh]	0000 0000	normally programmed to 00h (normal) <ul style="list-style-type: none"> <li>bits 7-0 = no address pitch adjustment when 0</li> </ul>	see Section 5.1, "Virtual Displays" on page 40
AUX[0Eh]	0000 0000	select palette address <ul style="list-style-type: none"> <li>bits 7-6 = green bank 0 (application specific)</li> <li>bits 5-4 = auto increment palette R/W access (application specific)</li> <li>bits 3-0 = palette address (application specific)</li> </ul>	
AUX[0Fh]	0000 0000	write Red data <ul style="list-style-type: none"> <li>bits 7-6 = red bank 0 (application specific)</li> <li>bits 5-4 = blue bank 0 (application specific)</li> <li>bits 3-0 = palette data (application specific)</li> </ul>	
AUX[0Fh]	0000 0000	write Green data	
AUX[0Fh]	0000 0000	write Blue data	
AUX[0Eh]	0000 0001	increment palette address	
AUX[0Fh]	0000 0010	write Red data	
AUX[0Fh]	0000 0010	write Green data	
AUX[0Fh]	0000 0101	write Blue data	
AUX[0Eh]	0000 0010	increment palette address	

<b>AUX Register</b>	<b>Data (in Binary)</b>	<b>Notes</b>	<b>See Also</b>
AUX[0Fh]	0000 0100	write Red data	
AUX[0Fh]	0000 0100	write Green data	
AUX[0Fh]	0000 1010	write Blue data	
AUX[0Eh]	0000 0011	increment palette address	
AUX[0Fh]	0000 0110	write Red data	
AUX[0Fh]	0000 0110	write Green data	
AUX[0Fh]	0000 1111	write Blue data	
AUX[0Eh]	0000 0100	increment palette address	
AUX[0Fh]	0000 1001	write Red data	
AUX[0Fh]	0000 1001	write Green data	
AUX[0Fh]	0000 1111	write Blue data	
AUX[0Eh]	0000 0101	increment palette address	
AUX[0Fh]	0000 1011	write Red data	
AUX[0Fh]	0000 1011	write Green data	
AUX[0Fh]	0000 1010	write Blue data	
AUX[0Eh]	0000 0110	increment palette address	
AUX[0Fh]	0000 1101	write Red data	
AUX[0Fh]	0000 1101	write Green data	
AUX[0Fh]	0000 0101	write Blue data	
AUX[0Eh]	0000 0111	increment palette address	
AUX[0Fh]	0000 1111	write Red data	
AUX[0Fh]	0000 1111	write Green data	
AUX[0Fh]	0000 0000	write Blue data	
AUX[0Eh]	0000 1000	increment palette address	
AUX[0Fh]	0000 1111	write Red data	
AUX[0Fh]	0000 1111	write Green data	
AUX[0Fh]	0000 0001	write Blue data	
AUX[0Eh]	0000 1001	increment palette address	
AUX[0Fh]	0000 1101	write Red data	
AUX[0Fh]	0000 1101	write Green data	
AUX[0Fh]	0000 0110	write Blue data	
AUX[0Eh]	0000 1010	increment palette address	
AUX[0Fh]	0000 1011	write Red data	
AUX[0Fh]	0000 1011	write Green data	
AUX[0Fh]	0000 1001	write Blue data	
AUX[0Eh]	0000 1100	increment palette address	
AUX[0Fh]	0000 0110	write Red data	
AUX[0Fh]	0000 0110	write Green data	



AUX Register	Data (in Binary)	Notes	See Also
AUX[0Fh]	0000 1101	write Blue data	
AUX[0Eh]	0000 1101	increment palette address	
AUX[0Fh]	0000 0100	write Red data	
AUX[0Fh]	0000 0100	write Green data	
AUX[0Fh]	0000 1001	write Blue data	
AUX[0Eh]	0000 1110	increment palette address	
AUX[0Fh]	0000 0010	write Red data	
AUX[0Fh]	0000 0010	write Green data	
AUX[0Fh]	0000 0100	write Blue data	
AUX[0Eh]	0000 1111	select palette address	
AUX[0Fh]	0000 0000	write Red data	
AUX[0Fh]	0000 0000	write Green data	
AUX[0Fh]	0000 0010	write Blue data	
AUX[01h]	1011 1001	program Mode Register bit DISP to 1, and set LCDE to enable power supply 1001 0000b 'OR' {original value for AUX[01h]} <ul style="list-style-type: none"> <li>• b7 = display on (application specific)</li> <li>• b4 = LCDE = LCDENB pin = set to enable specific power supply design (for SDU1353B0C, set bit to 1 to enable power supply) (application specific)</li> </ul>	

Write one pixel to the top left corner of display memory.  
 If the SDU1353B0C evaluation board is used in indexed I/O mode, there are two video memory banks which begin at D000:0000 (2 banks x 64K per bank; see the following note). If the base port address is 310h, then read from port address 312h. Next, write 0FFh to location D000:0000h; this will be seen as a white pixel at the top left corner of the display.

**Note**

A

$$\begin{aligned} \text{Line Byte Count} &= \left( \frac{\text{Bits Per Pixel}}{\text{Memory Interface Width}} \times \text{Horizontal Resolution} \right) - 1 \\ &= \left( \frac{8}{16} \times 320 \right) - 1 = 159 = 9Fh \end{aligned}$$

B Single Panel

$$\text{Total Display Line Count} = \text{Number Of Display Lines} - 1 = 240 - 1 = 239 = 0EFh$$

C Dual Panel

$$\text{Total Display Line Count} = \frac{\text{Number Of Display Lines}}{2} - 1$$

**Note**

The SDU1353B0C evaluation board maps the 128K of display memory into two banks of 64K, starting at D000:0000. This permits a VGA card to work along with the SED1353B0C card. Bank 0 represents the first 64K of display memory, and is selected by reading from the base port address+2. Bank 1 represents the second 64K of display memory, and is selected by writing to the base port address+2. The values read from or written to the base port address+2 are not important; only the action of reading or writing is significant. This method of memory banking will only work if the SDU1353B0C is set for indexed port I/O and is specific to this board.

**Example 2: Initialize the registers for a 4 gray shade 640 x 480 dual panel LCD with 128k of display memory. Afterwards write one pixel to the top left corner of the display's second panel.**

Program SED1353 Registers in the following order with the data supplied:

AUX Register	Data (in Binary)	Notes	See Also
AUX[00h]	0000 0000	<ul style="list-style-type: none"> <li>bits 7 and 6 must be zero</li> </ul>	
AUX[01h]	0100 0101	<ul style="list-style-type: none"> <li>b7 = display off (application specific; the recommended procedure is to turn this bit off during register initialization and afterwards turn this bit on)</li> <li>b6 = dual panel (panel specific)</li> <li>b5 = XSCL not masked (panel specific)</li> <li>b4 = LCDE = LCDENB pin = set to disable specific power supply design (for SDU1353B0C, set bit to 0 to disable power supply) (application specific; the recommended procedure is to disable the power supply during register initialization and afterwards enable the power supply)</li> <li>b3 = 4 grays when combined with AUX[03] bits 1 and 2 (application specific)</li> <li>b2 = 8 bit LCD data width (panel specific)</li> <li>b1 = 16 bit Memory Interface (implementation specific)</li> <li>b0 = RAMS ignored (implementation specific)</li> </ul>	
AUX[02h]	0100 1111	<ul style="list-style-type: none"> <li>bits 7-0 = bits 7-0 of Line Byte Count</li> <li>bit 8 of Line Byte Count is bit 0 of AUX[03h]</li> </ul>	see Note A at end of Table for calculation
AUX[03h]	0000 0000	<ul style="list-style-type: none"> <li>bits 7-6 = Power Save Mode 0 (application specific - for normal operation set to 00b)</li> <li>bit 5 = LCD interface signals forced low during Power Save (implementation and panel specific)</li> <li>bit 4 = no LUT bypass (application specific)</li> <li>bit 3 = 4 bit LCD data width when combined with AUX[01] bit 2 (panel specific)</li> <li>bit 2 = 4/16 gray shade mode (application specific)</li> <li>bit 1 = monochrome panel attached (panel specific)</li> <li>bit 0 = bit 8 of Line Byte Count (panel specific, see AUX[02h])</li> </ul>	see Section 5.6, "Power Saving" on page 54
AUX[04h]	1110 1111	<ul style="list-style-type: none"> <li>bits 7-0 = bits 7-0 of Total Display Line Count</li> <li>bits 9-8 of Total Display Line Count in bits 1-0 of AUX[05h]</li> </ul>	see Note B and C at end of Table for calculation
AUX[05h]	0000 0000	<ul style="list-style-type: none"> <li>bits 7-2: 0 = WF output toggles every frame (panel specific)</li> <li>bits 1-0 = bits 9-8 of Total Display Line Count (panel specific, see AUX[04h])</li> </ul>	

AUX Register	Data (in Binary)	Notes	See Also
AUX[06h] AUX[07h]	0000 0000 0000 0000	<ul style="list-style-type: none"> <li>bits 15-0 of Screen 1 Display Start Address - normally Screen 1 Start Address = 0000h (application and panel specific)</li> <li>bits 7-0 are in AUX[06h] and bits 15-8 are in AUX[07h]</li> <li>when 0000h, Screen 1 Display Start Address is located at D000:0000h, bank 0, on the SDU1353B0C</li> </ul>	see Section 4.2.1, "SDU1353B0C Evaluation Board Display Memory" on page 36 and Section 4.1, "Registers" on page 34
AUX[08h] AUX[09h]	0000 0000 0100 1011	<ul style="list-style-type: none"> <li>bits 15-0 of Screen 2 Display Start Address - normally Screen 2 Start Address = 4B00h (application and panel specific)</li> <li>bits 7-0 are in AUX[08h] and bits 15-8 are in AUX[09h]</li> <li>when 4B00h, Screen 2 Display Start Address is located at D000:9600h, bank 0, on the SDU1353B0C</li> </ul>	see Section 4.2.1, "SDU1353B0C Evaluation Board Display Memory" on page 36 and Section 4.1, "Registers" on page 34
AUX[0Ah]	1110 1111	<ul style="list-style-type: none"> <li>bits 7-0 = bits 7-0 of Screen 1 Display Line Count</li> <li>bits 9-8 of Screen 1 Display Line Count in bits 1-0 of AUX[0Bh]</li> <li>Screen 1 Display Line Count is typically the same as Total Display Line Count (AUX[0Ah] = AUX[04h], bits 1-0 of AUX[0Bh] = bits 1-0 of AUX[05h])</li> </ul>	see Section 5.4, "Split Screen" on page 45
AUX[0Bh]	0000 0000	<ul style="list-style-type: none"> <li>bits 7-2 = don't care; recommend clearing bits</li> <li>bits 1-0 = bits 9-8 of Screen 1 Display Line Count (application specific, see AUX[0Ah])</li> </ul>	
AUX[0Ch]	0000 0000	<p>normally programmed to 00h (panel specific)</p> <ul style="list-style-type: none"> <li>bits 7-0 = use fixed default non-display period</li> </ul>	
AUX[0Dh]	0000 0000	<p>normally programmed to 00h (normal)</p> <ul style="list-style-type: none"> <li>bits 7-0 = no address pitch adjustment when 0</li> </ul>	see Section 5.1, "Virtual Displays" on page 40
AUX[0Eh]	0000 0000	<p>select palette address</p> <ul style="list-style-type: none"> <li>bits 7-6 = green bank 0 (application specific)</li> <li>bits 5-4 = auto increment palette R/W access (application specific)</li> <li>bits 3-0 = palette address (application specific)</li> </ul>	
AUX[0Fh]	0000 0000	<p>write Red data</p> <ul style="list-style-type: none"> <li>bits 7-6 = red bank 0 (application specific)</li> <li>bits 5-4 = blue bank 0 (application specific)</li> <li>bits 3-0 = palette data (application specific)</li> </ul>	
AUX[0Fh]	0000 0000	write Green data	
AUX[0Fh]	0000 0000	write Blue data	
AUX[0Eh]	0000 0001	increment palette address	
AUX[0Fh]	0000 0010	write Red data	
AUX[0Fh]	0000 0010	write Green data	
AUX[0Fh]	0000 0101	write Blue data	
AUX[0Eh]	0000 0010	increment palette address	
AUX[0Fh]	0000 0100	write Red data	
AUX[0Fh]	0000 0100	write Green data	

<b>AUX Register</b>	<b>Data (in Binary)</b>	<b>Notes</b>	<b>See Also</b>
AUX[0Fh]	0000 1010	write Blue data	
AUX[0Eh]	0000 0011	increment palette address	
AUX[0Fh]	0000 0110	write Red data	
AUX[0Fh]	0000 0110	write Green data	
AUX[0Fh]	0000 1111	write Blue data	
AUX[0Eh]	0000 0100	increment palette address	
AUX[0Fh]	0000 1001	write Red data	
AUX[0Fh]	0000 1001	write Green data	
AUX[0Fh]	0000 1111	write Blue data	
AUX[0Eh]	0000 0101	increment palette address	
AUX[0Fh]	0000 1011	write Red data	
AUX[0Fh]	0000 1011	write Green data	
AUX[0Fh]	0000 1010	write Blue data	
AUX[0Eh]	0000 0110	increment palette address	
AUX[0Fh]	0000 1101	write Red data	
AUX[0Fh]	0000 1101	write Green data	
AUX[0Fh]	0000 0101	write Blue data	
AUX[0Eh]	0000 0111	increment palette address	
AUX[0Fh]	0000 1111	write Red data	
AUX[0Fh]	0000 1111	write Green data	
AUX[0Fh]	0000 0000	write Blue data	
AUX[0Eh]	0000 1000	increment palette address	
AUX[0Fh]	0000 1111	write Red data	
AUX[0Fh]	0000 1111	write Green data	
AUX[0Fh]	0000 0001	write Blue data	
AUX[0Eh]	0000 1001	increment palette address	
AUX[0Fh]	0000 1101	write Red data	
AUX[0Fh]	0000 1101	write Green data	
AUX[0Fh]	0000 0110	write Blue data	
AUX[0Eh]	0000 1010	increment palette address	
AUX[0Fh]	0000 1011	write Red data	
AUX[0Fh]	0000 1011	write Green data	
AUX[0Fh]	0000 1001	write Blue data	
AUX[0Eh]	0000 1100	increment palette address	
AUX[0Fh]	0000 0110	write Red data	
AUX[0Fh]	0000 0110	write Green data	
AUX[0Fh]	0000 1101	write Blue data	
AUX[0Eh]	0000 1101	increment palette address	

AUX Register	Data (in Binary)	Notes	See Also
AUX[0Fh]	0000 0100	write Red data	
AUX[0Fh]	0000 0100	write Green data	
AUX[0Fh]	0000 1001	write Blue data	
AUX[0Eh]	0000 1110	increment palette address	
AUX[0Fh]	0000 0010	write Red data	
AUX[0Fh]	0000 0010	write Green data	
AUX[0Fh]	0000 0100	write Blue data	
AUX[0Eh]	0000 1111	select palette address	
AUX[0Fh]	0000 0000	write Red data	
AUX[0Fh]	0000 0000	write Green data	
AUX[0Fh]	0000 0010	write Blue data	
AUX[01h]	1101 0101	program Mode Register bit DISP to 1, and set LCDE to enable power supply 1001 0000b 'OR' {original value for AUX[01h]} <ul style="list-style-type: none"> <li>• b7 = display on (application specific)</li> <li>• b4 = LCDE = LCDENB pin = set to enable specific power supply design (for SDU1353B0C, set bit to 1 to enable power supply) (application specific)</li> </ul>	

Write one pixel to the top left corner of the display's second panel.  
 If the SDU1353B0C evaluation board is used in indexed mode, there are two video memory banks which begin at D000:0000 (2 banks x 64K per bank; see the note on page 14). If the base port address is 310h, then read from port address 312h. Next, write 0C0h to location D000:9600h; this will be seen as a white pixel at the top left corner of the display's second panel.

**Note**

A.

$$\begin{aligned} \text{Line Byte Count} &= \left( \frac{\text{Bits Per Pixel}}{\text{Memory Interface Width}} \times \text{Horizontal Resolution} \right) - 1 \\ &= \left( \frac{2}{16} \times 640 \right) - 1 = 79 = 4Fh \end{aligned}$$

B Single Panel

$$\text{Total Display Line Count} = \text{Number Of Display Lines} - 1$$

C Dual Panel

$$\text{Total Display Line Count} = \frac{\text{Number Of Display Lines}}{2} - 1 = \frac{480}{2} - 1 = 239 = 0EFh$$

### 3 GRAY SHADES / COLORS AND LOOK-UP TABLES

This section discusses how the SED1353 shows color and monochrome images on LCD panels.

#### 3.1 Pixels

A pixel is physically stored in display memory as a series of bits. The more bits, the more colors the pixel can show.

Table 3-1: Number Of Bits As Related To Colors

Bits per Pixel	Levels of	
	Gray Shades	Colors
1	2	n/a
2	4	4
4	16	16
8	n/a	256

The following sections show how these pixels are stored in display memory.

#### 3.1.1 Memory Organization for One Bit Pixel (Black-and-White)

To store one bit pixels, eight pixels are grouped into one byte of display memory as shown below:

Bit 7	Bit 6	Bit 5	Bit 4	Bit 3	Bit 2	Bit 1	Bit 0
Pixel 0 Bit 0	Pixel 1 Bit 0	Pixel 2 Bit 0	Pixel 3 Bit 0	Pixel 4 Bit 0	Pixel 5 Bit 0	Pixel 6 Bit 0	Pixel 7 Bit 0

Figure 1: Pixel Storage For 1 Bit (Black-and-White) In One Byte Of Display Memory

When these pixels are shown, Pixel 0 is seen to be left of Pixel 1, Pixel 1 is seen to be left of Pixel 2, and so on. One bit pixels are only available on monochrome panels, and can only be displayed in black-and-white (no Look-Up Table is used).

#### 3.1.2 Memory Organization for Two Bit Pixels (4 Colors/Gray Shades)

To store two bit pixels, four pixels are grouped into one byte of display memory as shown below:

Bit 7	Bit 6	Bit 5	Bit 4	Bit 3	Bit 2	Bit 1	Bit 0
Pixel 0 Bit 1	Pixel 0 Bit 0	Pixel 1 Bit 1	Pixel 1 Bit 0	Pixel 2 Bit 1	Pixel 2 Bit 0	Pixel 3 Bit 1	Pixel 3 Bit 0

Figure 2: Pixel Storage For 2 Bits (4 Colors/Gray Shades) In One Byte Of Display Memory

When these pixels are shown, Pixel 0 is seen to be left of Pixel 1, Pixel 1 is seen to be left of Pixel 2, and so on. Two bit pixels are available in both monochrome and color panels.

### 3.1.3 Memory Organization for Four Bit Pixels (16 Colors/Gray Shades)

To store four bit pixels, two pixels are grouped into one byte of display memory as shown below:

Bit 7	Bit 6	Bit 5	Bit 4	Bit 3	Bit 2	Bit 1	Bit 0
Pixel 0 Bit 3	Pixel 0 Bit 2	Pixel 0 Bit 1	Pixel 0 Bit 0	Pixel 1 Bit 3	Pixel 1 Bit 2	Pixel 1 Bit 1	Pixel 1 Bit 0

*Figure 3: Pixel Storage For 4 Bits (16 Colors/gray Shades) In One Byte Of Display Memory*

When these pixels are shown, Pixel 0 is seen to be left of Pixel 1. For color panels, each four bit pixel represents an index into the red, green, and blue LUTs. For monochrome panels, each four bit pixel represents an index into the green LUT.

### 3.1.4 Memory Organization for Eight Bit Pixels (256 Colors)

To store eight bit pixels, one pixel is stored in one byte of display memory as shown below:

Bit 7	Bit 6	Bit 5	Bit 4	Bit 3	Bit 2	Bit 1	Bit 0
Red Bit 2	Red Bit 1	Red Bit 0	Green Bit 2	Green Bit 1	Green Bit 0	Blue Bit 1	Blue Bit 0

*Figure 4: Pixel Storage For 8 Bits (256 Colors) In One Byte Of Display Memory*

As shown above, the 256 color pixel is divided into three parts: three bits for red, three bits for green, and two bits for blue. The red bits represent an index into the red LUT, the green bits represent an index into the green LUT, and the blue bits represent an index into the blue LUT. Eight bit pixels are only available in color panels.

### 3.2 Look-Up Table (LUT)

This section provides a concise description of the LUT registers, followed by a description of the color and monochrome LUTs. Next is a series of examples which show how to initialize the LUTs, create an inverted LUT, and how to select one of four banks in both the 4 gray shade and color modes.

#### 3.2.1 LUT Registers

AUX[0E] Look-Up Table Address Register							
I/O address = 1110b, Read/Write							
Green Bank Bit 1	Green Bank Bit 0	ID Bit / RGB Index Bit 1	ID Bit / RGB Index Bit 0	Palette Address Bit 3	Palette Address Bit 2	Palette Address Bit 1	Palette Address Bit 0

The SED1353 has three internal 16 position, 4-bit wide Look-Up Tables (also referred to as palettes). The 4-bit value programmed into each table position determines the output gray shade / color weighting of display data. These tables are bypassed in black-and-white (BW) display mode.

These three 16 position Look-Up Tables can be arranged in many different configurations to accommodate all the gray shade / color display modes.

Refer to Look-Up Table Configurations on page 22 for formats.

bits 7-6      Green Bank Bits [1:0]  
 In 4-level gray / color display modes (2-bits/pixel), the 16 position Green palette is arranged into four, 4 position "banks". These two bits control which bank is currently selected. These bits have no effect in 16-level gray / color display modes (4-bits/pixel).  
 In 256 color display modes (8-bit/pixel), the 16 position Green palette is arranged into two, 8 position "banks" for the display of "green" colors. Only bit 0 of these two bits controls which bank is currently selected.

bits 5-4      ID Bit / RGB Index Bits [1:0]  
 These bits have dual purpose;

*ID Bits:* After "power on" or hardware reset, these bits can be read to identify the current revision of the SED1353. These same bits are used to identify the pin compatible SED1352F0x and would only be used in system implementations where common software is being used. As these bits are R/W they must be read before being written in order to be used as ID bits.

Table 3-2: ID Bit Usage

	Chip	Aux[0E]	
		bit 5	bit 4
Power On or RESET	SED1353F0A	0	0
	reserved	0	1
	SED1352F0B	1	0
	SED1352F0A	1	1



*RGB Index bits [1:0]:* These bits are also used to provide access to the three internal Look-Up Tables (RGB).

Table 3-3: Look-Up Table Access

Aux[0E]		Look-Up Table Access
bit 5	bit 4	
0	0	Auto-increment (see Note 1)
0	1	Red palette R/W access
1	0	Green palette R/W access
1	1	Blue palette R/W access

**Note**

When auto-increment is selected, an internal pointer will default to the Red palette on power on reset. Each read/write access to Aux[0F] will increment the counter to point to the next palette in order (RGB). Whenever the Look-Up Table Address register Aux[0E] is written, the RGB Index will reset the pointer to the Red palette. This provides a efficient method for sequential writing of RGB data.

bits 3-0            Palette Address Bits [3:0]  
These 4 bits provide a pointer into the 16 position Look-Up Table currently selected for CPU R/W access.

**Note**

The Look-Up Table configuration (e.g. 1/2/4 banks) does not affect the R/W access from the CPU. All 16 positions can be accessed sequentially.

AUX[0F] Look-Up Table Data Register							
I/O address = 1111b, Read/Write.							
Red Bank Bit 1	Red Bank Bit 0	Blue Bank Bit 1	Blue Bank Bit 0	Palette Data Bit 3	Palette Data Bit 2	Palette Data Bit 1	Palette Data Bit 0

bit 7-6            Red Bank Bits [1:0]  
In 4-level color display modes, the 16 position Red palette is arranged into four, 4 position “banks”. These two bits control which bank is currently selected.  
In 256 color display modes, the 16 position, Red palette is arranged into two, 8 position “banks” for the display of “red” colors. Only bit 0 of these two bits controls which bank is currently selected.  
These bits have no effect in all gray shade or 16-color display modes.

bit 5-4            Blue Bank Bits [1:0]  
In both the 4 and 256 color display modes, the 16 position Blue palette is arranged into four 4 position “banks” for the display of “blue” colors. These two bits control which bank is currently selected.  
These bits have no effect in all gray shade display modes or 16 color display modes.

bits 3-0            Palette Data Bits [3:0]  
These 4-bits are the gray shade / color values used for display data output. They are programmed into the 4-bit Look-Up Table (palettes) positions pointed to by Palette Address bits [3:0] and RGB Index bit[1:0] (if in color display modes).

For example; in a 16-level gray shade display mode, a data value of 0001b (4-bits / pixel) will point to Look-Up Table position one and display the 4-bit gray shade corresponding to the value programmed into that location.

### 3.2.2 Look-Up Table Description

- The Look-Up Table (LUT, or palette) treats the value of a pixel as an index into an array of colors or gray shades. For example, a pixel value of zero would point to the first LUT entry; a pixel value of 7 would point to the eighth LUT entry.
- The value inside each LUT entry represents the intensity of the given color or gray shade. This value ranges between 0 and 0Fh.
- The SED1353FOA Look-Up table is linear; increasing the LUT entry number results in a lighter color or gray shade. For example, a LUT entry of 0Fh into the red Look-Up entry will always result in a bright red output. An entry of 00h into a Look-Up entry will always result in the removal of this color (black if monochrome).
- Because LUT entries represent the actual colors shown on the LCD panel, pixel values indirectly select which color or gray shade to display.
- When the number of bits in a pixel is less than 4, there are several different LUT configurations based on whether the display is monochrome or color, and the number of gray shades or colors.

Table 3-4: Look-Up Table Configurations

Display Mode	4-bit wide Palette		
	RED	GREEN	BLUE
Black & White			
4-level gray		4 banks of 4	
16-level gray		1 bank of 16	
4 color	4 banks of 4	4 banks of 4	4 banks of 4
16 color	1 bank of 16	1 bank of 16	1 bank of 16
256 color	2 banks of 8	2 banks of 8	4 banks of 4

 Indicates the palette is not used for that display mode

#### 3.2.2.1 Color Mode

In color mode, the SED1353 supports three 16 position, 4 bit wide color LUTs (red, green, and blue). Depending on the selected pixel size, these LUTs will provide from 1 to 4 banks.

- 2 bits-per-pixel (4 colors)  
In this format the pixel is an index into the red, green, and blue LUTs. Each color LUT supports 4 banks (see Section 3.2.5, “*Four Colors (Two Bits/Pixel in Color Mode)*” on page 28).
- 4 bits-per-pixel (16 colors)  
In this format the pixel is an index into the red, green, and blue LUTs. Each color LUT supports only one bank (see Section 3.2.7, “*Sixteen Colors (Four Bits/Pixel in Color Mode)*” on page 31).
- 8 bits-per-pixel (256 colors)  
In this format the pixel is divided into three parts: 3 bits for red, 3 bits for green, and 2 bits for blue. If the red, green, and blue LUTs were programmed to show a linear increase in intensity of the given color, the 8 bit pixel describes the intensity of the given set of colors. For example, a pixel value of 00h would be black, E0h would be bright red, 1Ch would be bright green, and 03h would be bright blue. Because there are 16 entries for each color LUT, the SED1353 provides two red banks, two green banks, and four blue banks in 256 color mode (see Section 3.2.8, “*256 Colors (Eight Bits/Pixel in Color Mode)*” on page 32).

### 3.2.2.2 Monochrome Mode

In monochrome mode, the SED1353 treats the green LUT as a 16 position, 4 bit wide monochrome LUT. Depending on the selected pixel size, this LUT will provide from 1 to 4 banks.

- 1 bit-per-pixel (black-and-white)  
 In this format no LUT is used. A pixel value of 0 is black, and a pixel value of 1 is white.
- 2 bits-per-pixel (4 gray shades)  
 In this format the pixel is an index into the monochrome LUT. The monochrome LUT supports 4 banks (see Section 3.2.4, “Four Gray Shades (Two Bits/Pixel in Monochrome Mode)” on page 26).
- 4 bits-per-pixel (16 gray shades)  
 In this format the pixel is an index into the monochrome LUT. The monochrome LUT supports only one bank (see Section 3.2.6, “Sixteen Gray Shades (Four Bits/Pixel in Monochrome Mode)” on page 30).

**Example 3: Initialize the Look-Up Table for 256 Colors (Bank 0 Only)**

Table 3-5 shows the color LUTs with intensities starting from black (index 0) and finishing in maximum color intensity (at the largest index available for the color in bank 0). For example, the red LUT would have a maximum intensity at index 07h, the green LUT would have a maximum intensity at index 07h, and the blue LUT would have a maximum intensity at index 03h. A normal display would use bank 0 for the red, green, and blue LUTs.

1. Write LUT index to Look-Up Table Address Register AUX[0Eh], set to automatic increment mode.
2. Write red LUT entry value to Look-Up Table Data Register AUX[0Fh].
3. Write green LUT entry value to Look-Up Table Data Register AUX[0Fh].
4. Write blue LUT entry value to Look-Up Table Data Register AUX[0Fh].
5. Repeat steps 1-4 until all 16 LUT entries have been written.

Table 3-5: Sed1353F0A Color Look-up Table For 256 Color Mode

Index (hex)	Red LUT (hex)	Green LUT (hex)	Blue LUT (hex)
0	0	0	0
1	2	2	5
2	4	4	A
3	6	6	F
4	9	9	X
5	B	B	X
6	D	D	X
7	F	F	X

Where X is Don't Care

**Example 4: Initialize the Look-Up Table for 16 Gray Shades**

The following describes how to initialize the Look-Up table for 16 gray shades. Table 3-6 shows a LUT with gray shades starting from black (index 0) and finishing in white (index 15, or 0Fh).

1. Write LUT index to Look-Up Table Address Register AUX[0Eh].
2. Write LUT entry value to Look-Up Table Data Register AUX[0Fh].
3. Repeat steps 1 and 2 until all 16 LUT entries have been written.

*Table 3-6: SED1353 Black-To-White Look-Up Table*

<b>Index (hex)</b>	<b>Look-Up Table (hex)</b>	<b>Index (hex)</b>	<b>Look-Up Table (hex)</b>
0	0	8	8
1	1	9	9
2	2	A	A
3	3	B	B
4	4	C	C
5	5	D	D
6	6	E	E
7	7	F	F

**Example 5: Initialize an Inverted Look-Up Table**

This example shows how to invert an image by changing only the LUT. Inverting means that pixels formally shown as light gray shades are now shown as dark gray shades, and vice versa. It does not matter whether the SED1353 is in 4 gray shade or 16 gray shade mode.

1. Read LUT entry.  
Write LUT index to Look-Up Table Address Register AUX[0Eh]  
Read “Old LUT Entry” from Look-Up Table Data Register AUX[0Fh]
2. Calculate “New LUT Entry” according to the following formula:

$$\text{New LUT Entry} = 15 - \text{Old LUT Entry}$$

3. Write LUT entry back.  
Write LUT index to Look-Up Table Address Register AUX[0Eh]  
Write “New LUT Entry” to Look-Up Table Data Register AUX[0Fh]
4. Repeat steps 1 to 3 until all 16 LUT entries have been changed.

If Table 3-6 was previously programmed into the SED1353, the new inverted LUT would be the following:

*Table 3-7: SED1353 Inverted Look-Up Table (White-To-Black)*

Index (hex)	Look-Up Table (hex)	Index (hex)	Look-Up Table (hex)
0	F	8	7
1	E	9	6
2	D	A	5
3	C	B	4
4	B	C	3
5	A	D	2
6	9	E	1
7	8	F	0

**3.2.3 Black-and-White (One Bit/Pixel)**

When the SED1353 is configured for one bit pixels, the monochrome (green) LUT is not used. Instead, a pixel value of 0 represents black and a pixel value of 1 represents white.

**Note**

One bit/pixel is only available in monochrome mode.

### 3.2.4 Four Gray Shades (Two Bits/Pixel in Monochrome Mode)

When the SED1353 is configured for two bit pixels in monochrome mode, each pixel can index one of four monochrome LUT entries. Note that in monochrome mode, the SED1353 uses the green LUT as the monochrome LUT. The 16 LUT entries are divided into four separate Look-Up tables or *banks*, each having four entries (see Figure 5). The following examples show how to program and select these banks.

**Example 6: In 4 gray shade mode, program bank 2 LUT entries and select for use.**

- Determine location of bank 2 in LUT.  
The first four entries in the 16 entry LUT represent the first bank (bank 0). The following four entries in the LUT represent the second bank (bank 1), etc. Consequently bank 2 starts at LUT index 8 as shown below:

$$\begin{aligned} \text{start of bank index} &= \text{bank number} \times 4 \\ \text{start of bank 2} &= 2 \times 4 = 8 \end{aligned}$$

Monochrome (green) Bank 2 is shown in Figure 5.

- Write LUT index to Look-Up Table Address Register AUX[0Eh].  
For bank 2, the index will one of the following values: 08h, 09h, 0Ah, or 0Bh
- Write LUT entry value to Look-Up Table Data Register AUX[0Fh].  
For a linear LUT, use the Look-Up table entries in Table 3-8, "SED1353 Black-To-White Look-up Table For 4 Gray Shades," on page 26.
- Repeat steps 2 and 3 until all 4 LUT entries have been written.
- To display data using Bank 2, write 10b to AUX[0E] bits 7,6.

Table 3-8: SED1353 Black-To-White Look-up Table For 4 Gray Shades

Index (hex)	Look-Up Table (hex)
8	0
9	5
A	A
B	F

4-Level Gray Shade Mode

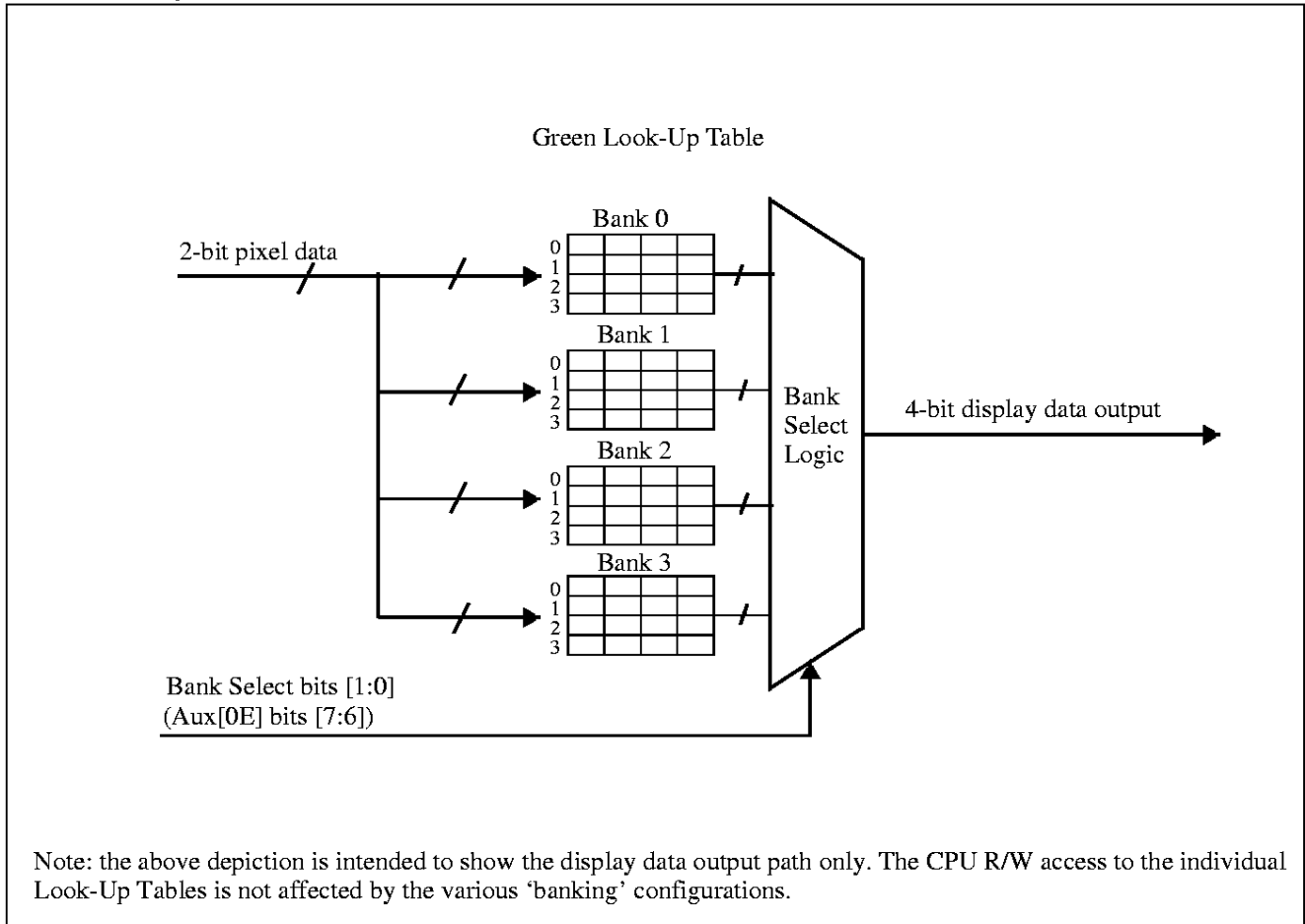

Figure 5: 4-Level Gray-Shade Mode Look-Up Table Architecture

### 3.2.5 Four Colors (Two Bits/Pixel in Color Mode)

When the SED1353 is configured for two bit pixels in color mode, each pixel can index one of four color LUT entries. The 16 LUT entries are divided into four separate Look-Up tables or *banks*, each having four entries (see Figure 6). The following examples show how to program and select these banks.

**Example 7: In 4 color mode, program red bank 3 LUT entries and select for use.**

- Determine location of bank 3 in the red LUT.  
The first four entries in the 16 entry LUT represent the first bank (bank 0). The following four entries in the LUT represent the second bank (bank 1), etc. Consequently bank 3 starts at LUT index 0Ch as shown below:

$$\begin{aligned} \text{start of bank index} &= \text{bank number} \times 4 \\ \text{start of bank 3} &= 3 \times 4 = 12 = 0Ch \end{aligned}$$

Red Bank 3 is shown in Figure 6.

- Write LUT index and Red LUT selection to Look-Up Table Address Register AUX[0Eh].  
AUX[0Eh] = LUT index 'OR' 0001 0000b  
For bank 3, the index will one of the following values: 0Ch, 0Dh, 0Eh, or 0Fh, so the value written to AUX[0Eh] will be one of the following: 1Ch, 1Dh, 1Eh, or 1Fh. This selects the Red LUT only, indexes C, D, E and F.
- Write LUT entry value to Look-Up Table Data Register AUX[0Fh].  
For a linear LUT, use the Look-Up table entries in Table 3-9, "SED1353 Low To High Intensity Color Look-Up Table For 4 Colors," on page 28.
- Repeat steps 2 and 3 until all 4 LUT entries have been written.
- To display data using Red Bank 3 write 11b to AUX[0F] bits 7,6:  
AUX[0Fh] = original AUX[0Fh] 'OR' 1100 0000b

Table 3-9: SED1353 Low To High Intensity Color Look-Up Table For 4 Colors

Index (hex)	Look-Up Table (hex)
C	0
D	5
E	A
F	F



**4-Level Color Mode**

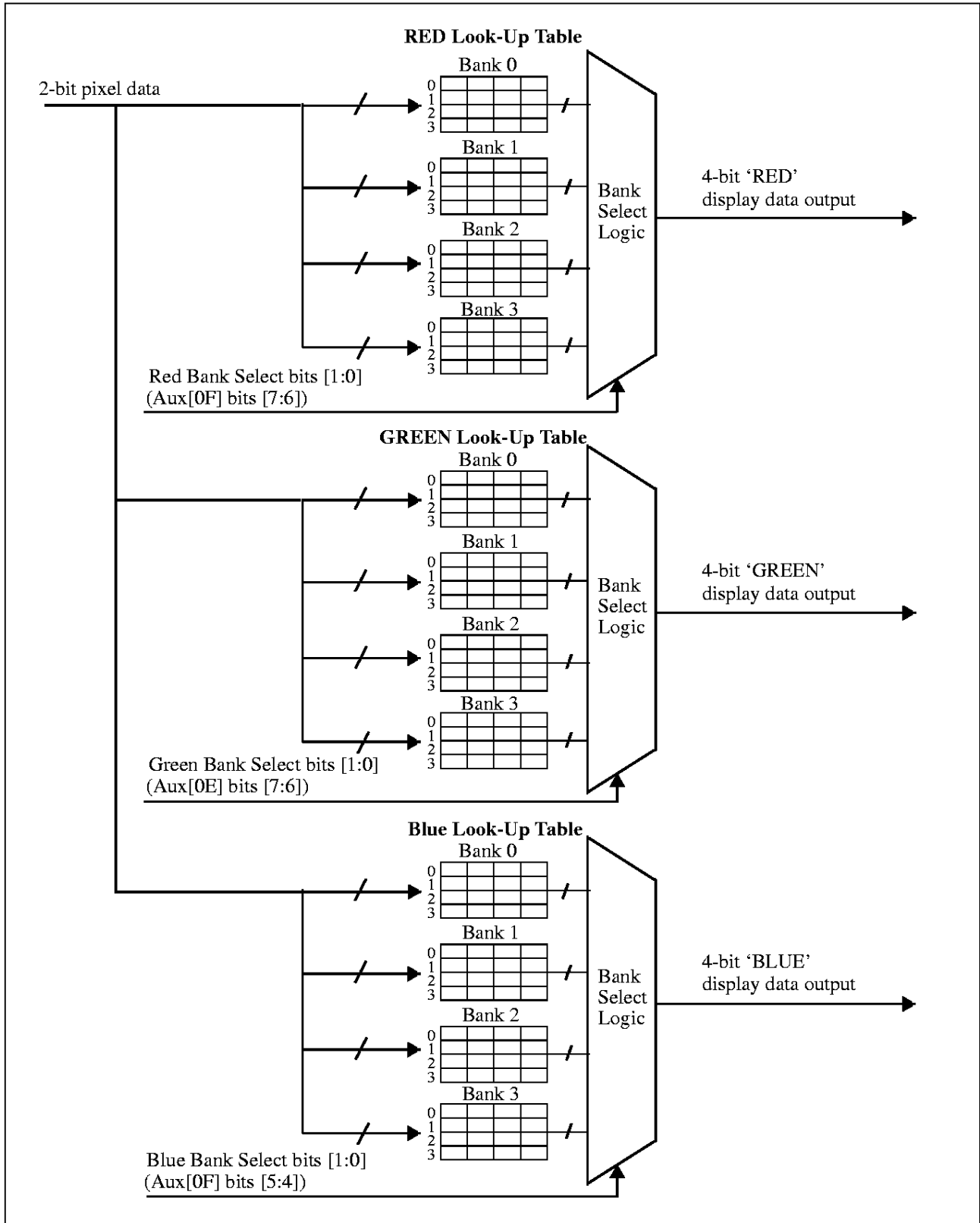

Figure 6: 4-Level Color Mode Look-Up Table Architecture

### 3.2.6 Sixteen Gray Shades (Four Bits/Pixel in Monochrome Mode)

When the SED1353 has 4-bit monochrome pixels, each pixel can index into one of 16 LUT entries. The LUT bank bits are ignored in this mode.

#### 16-Level Gray Shade Mode

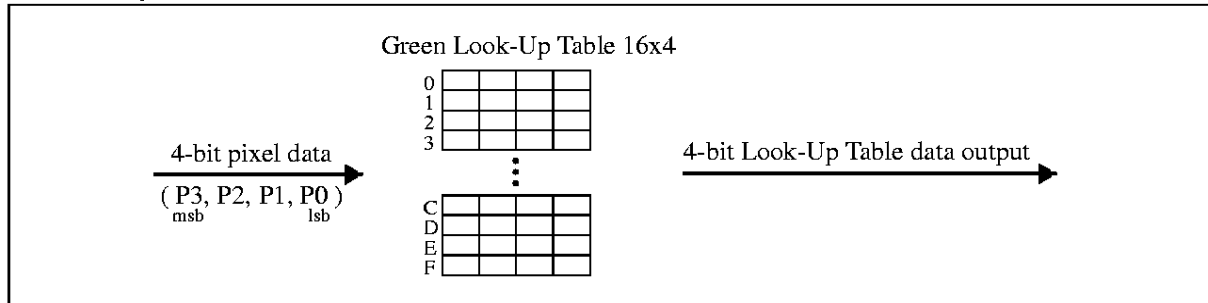

Figure 7: 16-Level Gray-Shade Mode Look-Up Table Architecture

### 3.2.7 Sixteen Colors (Four Bits/Pixel in Color Mode)

When the SED1353 has 4-bit color pixels, each pixel can index into each of the three color LUTs. The LUT bank bits are ignored in this mode.

#### 16-Level Color Mode

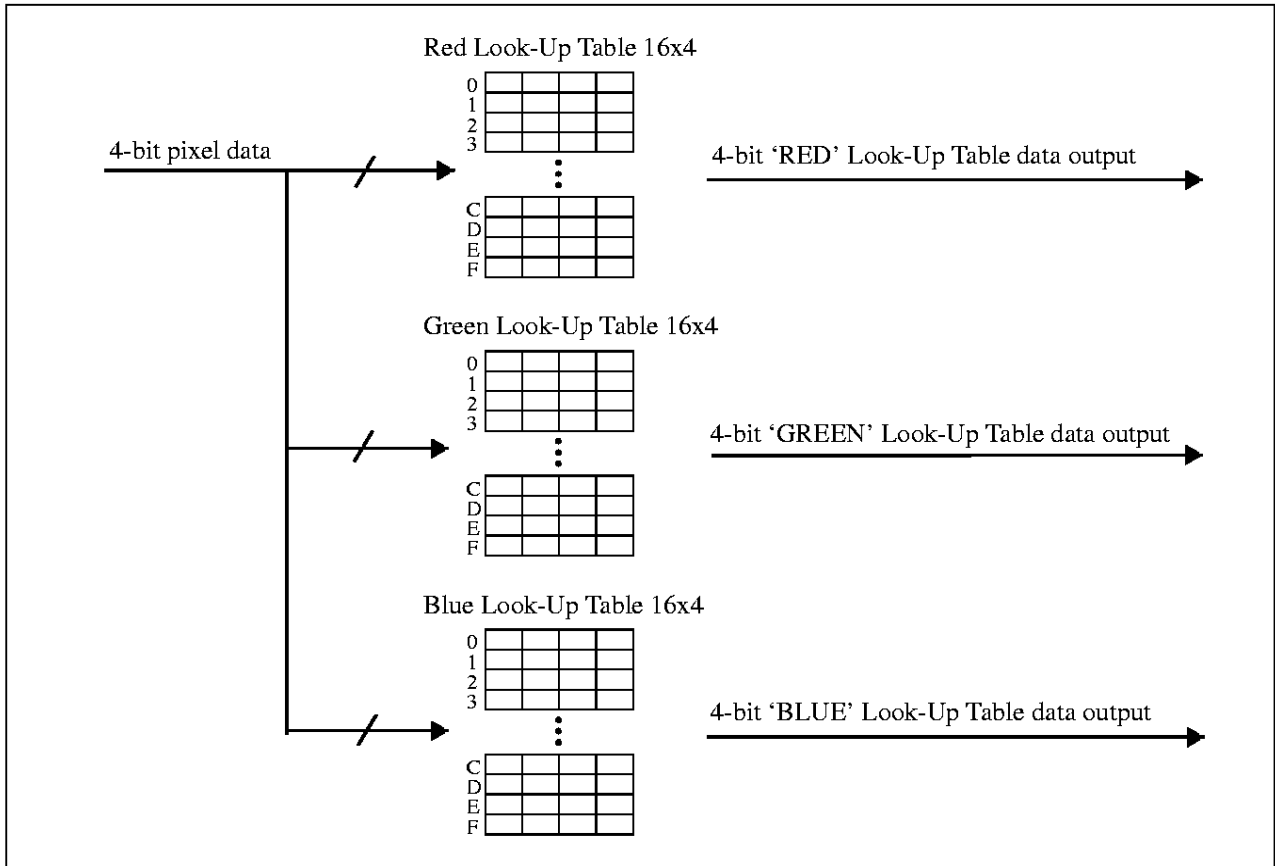

Figure 8: 16-Level Color Mode Look-Up Table Architecture

Table 3-10: Simulation Of First 16 Entries Of Standard VGA Palette

Address	Red	Green	Blue	Address	Red	Green	Blue
00	00	00	00	08	00	00	00
01	00	00	0A	09	00	00	0F
02	00	0A	00	0A	00	0F	00
03	00	0A	0A	0B	00	0F	0F
04	0A	00	00	0C	0F	00	00
05	0A	00	0A	0D	0F	00	0F
06	0A	0A	00	0E	0F	0F	00
07	0A	0A	0A	0F	0F	0F	0F

### 3.2.8 256 Colors (Eight Bits/Pixel in Color Mode)

When the SED1353 has 8-bit color pixels, bits 7-5 represent the red LUT index, bits 4-2 represent the green LUT index, and bits 1-0 represent the blue LUT index (see Figure 9, “256-Level Color Mode Look-Up Table Architecture,” on page 33). It is recommended that the three LUTs are programmed according to Table 3-5, “Sed1353F0A Color Look-up Table For 256 Color Mode,” on page 23, and only bank 0 were used for each of the three colors. This method results in each color index inside the pixel to represent its respective color intensity (see Table 3-11 below).

*Table 3-11: Examples Of 256 Pixel Colors Using Linear LUT*

Pixel Value (binary)	Color	Pixel Value (binary)	Color
000 000 00	black	000 000 00	black
000 000 10	dark blue	000 000 11	bright blue
000 100 00	dark green	000 111 00	bright green
000 100 10	dark cyan	000 111 11	bright cyan
100 000 00	dark red	111 000 00	bright red
100 000 10	dark magenta	111 000 11	bright magenta
100 100 00	dark yellow	111 111 00	bright yellow
100 100 10	gray	111 111 11	white

**256-Level Color Mode**

**256 Color Data Format:**

7	6	5	4	3	2	1	0
R <sub>2</sub>	R <sub>1</sub>	R <sub>0</sub>	G <sub>2</sub>	G <sub>1</sub>	G <sub>0</sub>	B <sub>1</sub>	B <sub>0</sub>

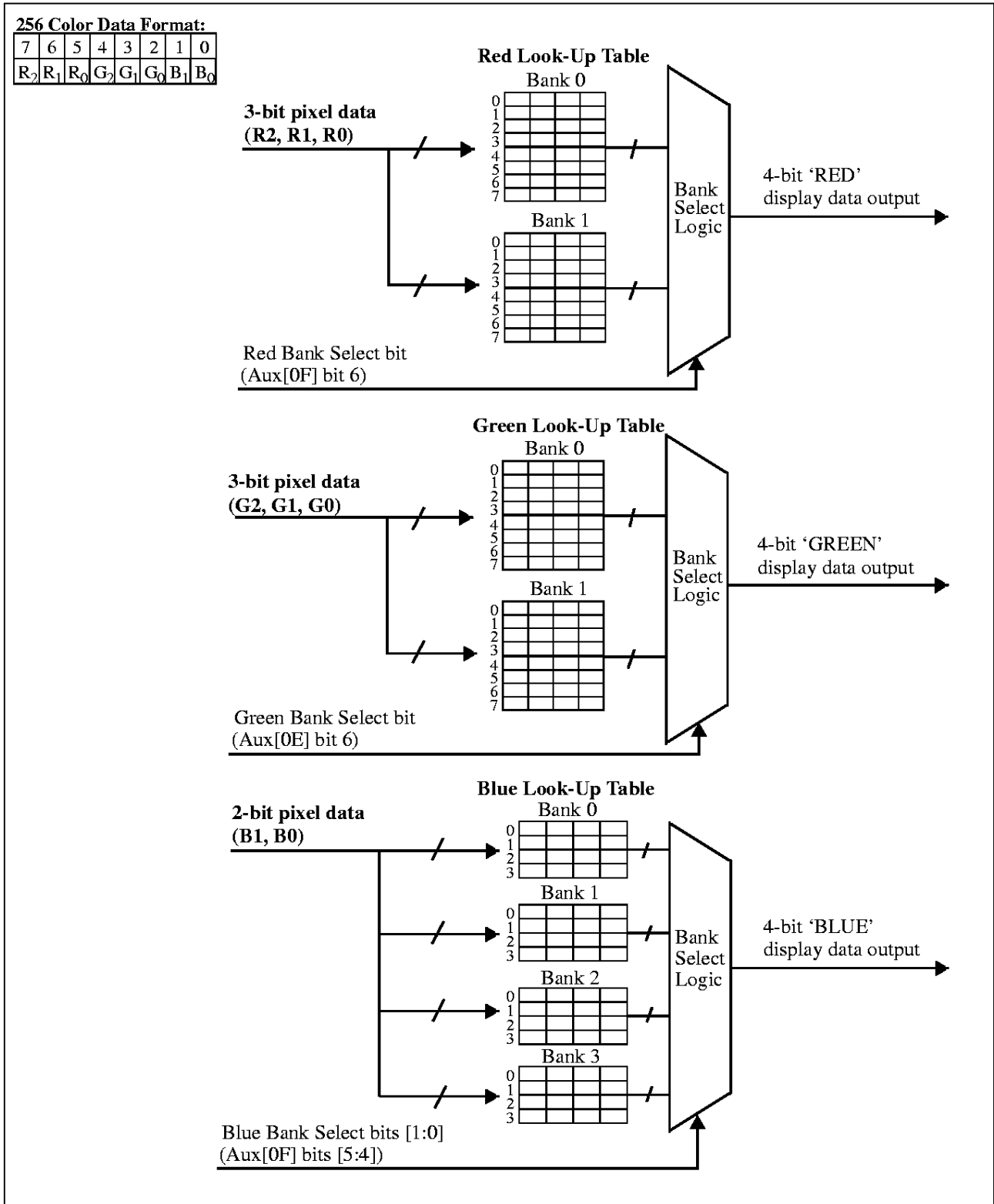

Figure 9: 256-Level Color Mode Look-Up Table Architecture

## 4 DISPLAY MEMORY MODELS

This section includes a concise description of the Display Start Address Registers, followed by a description of display memory. Afterwards examples are provided, illustrating how to calculate the display memory model for a given display resolution and color/gray level mode. Once this model is calculated, examples on programming the Display Start Address Registers are provided.

### 4.1 Registers

Register bits discussed in this section are highlighted.

<b>AUX[01] Mode Register 0</b> I/O address = 0001b, Read/Write.							
DISP	Panel	Mask XSCL	LCDE	Gray Shade / Color	LCD Data Width Bit 0	Memory Interface	RAMS

bit 1 Memory Interface  
This bit selects between the 8-bit or 16-bit memory interface. When this bit = 0, the 16-bit memory interface is selected. When this bit = 1, the 8-bit memory interface is selected. If 16-bit bus interface (VD0 = 1 on RESET) or 256 color mode (AUX[03] bits 2-1 = 11) is selected, the Memory Interface bit is forced to 0 internally (16-bit). This bit goes low on RESET.

<b>AUX[06] Screen 1 Display Start Address Register (LSB)</b> I/O address = 0110b, Read/Write.							
Screen 1 Display Start Addr Bit 7	Screen 1 Display Start Addr Bit 6	Screen 1 Display Start Addr Bit 5	Screen 1 Display Start Addr Bit 4	Screen 1 Display Start Addr Bit 3	Screen 1 Display Start Addr Bit 2	Screen 1 Display Start Addr Bit 1	Screen 1 Display Start Addr Bit 0

<b>AUX[07] Screen 1 Display Start Address Register (MSB)</b> I/O address = 0111b, Read/Write.							
Screen 1 Display Start Addr Bit 15	Screen 1 Display Start Addr Bit 14	Screen 1 Display Start Addr Bit 13	Screen 1 Display Start Addr Bit 12	Screen 1 Display Start Addr Bit 11	Screen 1 Display Start Addr Bit 10	Screen 1 Display Start Addr Bit 9	Screen 1 Display Start Addr Bit 8

AUX[06] bits 7-0 Screen 1 Display Start Address Bits [15:0]  
AUX[07] bits 7-0 These 16 bits determine the Screen 1 Display Start Address. In an 8-bit memory configuration these bits set the 16-bit start address (i.e., byte access). In a 16-bit memory configuration these are the 16 most significant bits of a 17-bit start address (i.e., word access).

**Note**

The absolute address into display memory is determined by the Memory Mapping Address which is set by the reset state of VD13 - VD15.

The Screen 1 Display Start Address is the memory address corresponding to the first displayed pixel (top left corner). In a dual panel configuration, screen 1 refers to the upper half of the display. While in a single panel configuration, screen 1 refers to the first screen of the Split Screen Display feature where two different images (screen 1 and screen 2) can be displayed at the same time on one display.

**AUX[08] Screen 2 Display Start Address Register (LSB)**

I/O address = 1000b, Read/Write.

Screen 2 Display Start Addr Bit 7	Screen 2 Display Start Addr Bit 6	Screen 2 Display Start Addr Bit 5	Screen 2 Display Start Addr Bit 4	Screen 2 Display Start Addr Bit 3	Screen 2 Display Start Addr Bit 2	Screen 2 Display Start Addr Bit 1	Screen 2 Display Start Addr Bit 0
--	--	--	--	--	--	--	--

**AUX[09] Screen 2 Display Start Address Register (MSB)**

I/O address = 1001b, Read/Write.

Screen 2 Display Start Addr Bit 15	Screen 2 Display Start Addr Bit 14	Screen 2 Display Start Addr Bit 13	Screen 2 Display Start Addr Bit 12	Screen 2 Display Start Addr Bit 11	Screen 2 Display Start Addr Bit 10	Screen 2 Display Start Addr Bit 9	Screen 2 Display Start Addr Bit 8
---	---	---	---	---	---	--	--

AUX[08] bits 7-0 Screen 2 Display Start Address Bits [15:0]

AUX[09] bits 7-0 These 16 bits determine the Screen 2 Display Start Address. In an 8-bit memory configuration these bits set the 16-bit start address (i.e., byte access). In a 16-bit memory configuration these are the 16 most significant bits of a 17-bit start address (i.e., word access).

In a dual panel configuration, screen 2 refers to the lower half of the display. The Screen 2 Display Start Address is the memory address corresponding to the first displayed pixel in the first line of the lower half of the display. If screen 2 is started right after screen 1, the screen 2 display start address can be calculated with the following formula:

$$Screen2DisplayStartAddress(hex) = \frac{(ImageHorizontalResolution) \times (ImageVerticalResolution) \times (BytesPerPixel)}{2 \times \left( \frac{MemoryInterfaceWidth}{8} \right)} + Screen1DisplayStartAddress$$

In a single panel configuration, screen 2 refers to the second screen of the Split Screen Display Feature where two different images (screen 1 and screen 2) can be displayed at the same time on one display. The Screen 2 Display Start Address is the memory address corresponding to the first pixel of the second image stored in display memory. To display screen 2 refer to AUX[0A] Screen 1 Display Line Count Register (LSB) on page 45.

## 4.2 Description

When displaying an image, the SED1353 must read pixel data from display memory. This memory is organized to match the display resolution of the given LCD panel. To organize display memory, the following registers must be programmed:

1. Screen 1 Display Start Address Registers
2. Screen 2 Display Start Address Registers
3. Address Pitch Adjustment Register

For the first example, the Address Pitch Adjustment Register is programmed to zero. This means that no virtual display is available; for information on virtual displays see Section 5.1, “*Virtual Displays*” on page 40.

### 4.2.1 SDU1353B0C Evaluation Board Display Memory

There are several issues to consider when programming the Screen Display Start Address Registers for the SDU1353B0C evaluation board:

- The SDU1353B0C is always set for 128k of display memory. This memory exists as two 64k banks at addresses D000:0000h to D000:FFFFh. To access bank 0, read from the base port address + 2. To access bank 1, write to base port address + 2. The values read from or written to base port address + 2 are not important. The start of bank 0 represents the top left corner of display memory.
- For the SDU1353B0C, the Screen Display Start Address Registers are always in reference to the display memory address D000:0000h, bank 0. Writing 0 to a Display Start Address Register will always refer to D000:0000h, bank 0.
- Although the SED1353 can set the Memory Interface to 8 or 16 bits, the SDU1353B0C evaluation board must be set for 16 bits in order to access 128k of display memory. As a result, the Display Start Address Registers are word pointers, not byte pointers. To illustrate how to use a word pointer, refer to Example 8. In general, any system which uses more than 64k of display memory must *always* have the Memory Interface set to 16 bits.

**Example 8:** *For the SDU1353B0C, calculate the required start address register value which refers to location D000:0000h, bank 1.*

Location D000:0000h bank 1 refers to the start of the second 64k bank of display memory. Consequently the start address is 10000h bytes (64k), or 8000h words.

START ADDRESS[LSB] = 00h

START ADDRESS[MSB] = 80h



## 4.2.2 Display Start Address Registers

This section illustrates how to properly calculate the values for the Screen Start Address Registers for a given LCD panel resolution. However, this section is limited to single panel displays; refer to Section 5.4.3, “Dual Panel LCD” on page 48 to program the Screen Start Address Registers for a dual panel display.

In the following example, the Display Start Address Registers are programmed for a 16 color 320 x 240 single panel LCD display. The technique shown, however, can also be used to calculate the memory map of other resolutions. In addition, reference is made to the SDU1353B0C evaluation board; other hardware implementations of the SED1353 may assign different display and port addresses from those of the SDU1353B0C. Refer to the *SDU1353B0C Evaluation Board User's Manual* for more information on these hardware issues.

**Example 9: Program the Display Start Address Registers for a single LCD panel; the display is attached to the SDU1353B0C evaluation board.**

Normally images are loaded at the start of display memory (D000:0000h, bank 0), so the display start address registers must be set to 0000h words.

AUX[06h] = 00h

AUX[07h] = 00h

**Example 10: Program the Display Start Address Registers for a dual panel LCD.**

Refer to Section 5.4.3.1, “Displaying a Single Image on a Dual Panel” on page 50.

**Example 11: Determine if the SED1353 implementation can support a 640 x 480 LCD with 4 colors.**

1. Calculate the number of bytes per scan line:

$$\frac{\text{pixels per scan line}}{\text{pixels per byte}} = \frac{640}{4} = 160 \text{ bytes per scan line}$$

2. Calculate the total number of bytes required for display memory:

$$(160 \text{ bytes per scan line})(480 \text{ scan lines}) = 76800 \text{ bytes}$$

3. Compare the required number of bytes with the amount of memory available to the SED1353.
  - The SED1353 has 128k available, so there is 131,072 bytes available. Since this number is greater than the 76,800 bytes required for 640 x 480 with 4 colors, the SED1353 implementation can support a 640 x 480 LCD with 4 colors.

**Note**

The memory required for 4 colors at 640 x 480 is the same as the memory required for 4 gray shades at 640 x 480. Consequently the SED1353 implementation can also support a 640 x 480 LCD with 4 gray shades.

### 4.3 Common Display Memory Requirements for LCD Panel Sizes:

The following is a list of memory requirements and memory maps for common LCD resolutions. Note that the memory required for 640 x 480 with 4 or 16 bits/pixel exceeds 128k and is therefore not supported on the SED1353.

Table 4-1: Memory Size Requirements

Display Resolution	Pixel Storage		Memory Requirements	
	Bits/Pixel	Colors/Gray Shades	Bytes	Hex
320 x 240	1	2	9,600	0000 2580
	2	4	19,200	0000 4B00
	4	16	38,400	0000 9600
	8	256	76,800	0001 2C00
480 x 240	1	2	14,400	0000 3840
	2	4	28,800	0000 7080
	4	16	57,600	0000 E100
	8	256	115,200	0001 C200
640 x 200	1	2	16,000	0000 3E80
	2	4	32,000	0000 7D00
	4	16	64,000	0000 FA00
	8	256	128,000	0001 F400
640 x 480	1	2	38,400	0000 9600
	2	4	76,800	0001 2C00
	4	16	N/A	N/A
	8	256	N/A	N/A

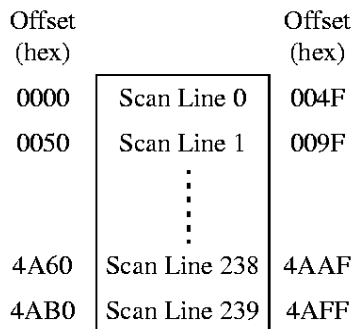

Figure 10: Memory Map Example For 320 x 240 LCD Panel With 4 Colors/Gray Shades

Offset (hex)		Offset (hex)
0000 0000	Scan Line 0	0000 013F
0000 0140	Scan Line 1	027F
	⋮	
0001 2980	Scan Line 238	0001 2ABF
0001 2AC0	Scan Line 239	0001 2BFF

Figure 11: Memory Map Example For 320 x 240 LCD Panel With 256 Colors

Offset (hex)		Offset (hex)
0000	Scan Line 0	013F
0140	Scan Line 1	027F
	⋮	
F780	Scan Line 198	F8BF
F8C0	Scan Line 199	F9FF

Figure 12: Memory Map Example For 640 x 200 LCD Panel With 16 Colors/Gray Shades

## 5 ADVANCED TECHNIQUES

This section presents information on the following:

- virtual displays
- bitmaps and text displays
- reading and writing to the SED1353 registers
- split screen displays
- panning and scrolling
- power saving

### 5.1 Virtual Displays

This section presents a detailed description of the Address Pitch Adjustment Register, followed by a description of a virtual display. Afterwards an example is given, showing how to create a virtual display.

#### 5.1.1 Registers

Register bits discussed in this section are highlighted.

AUX[0D] Address Pitch Adjustment Register							
I/O address = 1101b, Read/Write.							
Addr Pitch Adjustment Bit 7	Addr Pitch Adjustment Bit 6	Addr Pitch Adjustment Bit 5	Addr Pitch Adjustment Bit 4	Addr Pitch Adjustment Bit 3	Addr Pitch Adjustment Bit 2	Addr Pitch Adjustment Bit 1	Addr Pitch Adjustment Bit 0

bits 7-0

Address Pitch Adjustment Bits [7:0]

This register controls the virtual display by setting the numerical difference between the last address of a display line, and the first address in the following line.

If the Address Pitch Adjustment is not equal to zero, then a virtual screen is formed. The size of the virtual screen is only limited by the available display memory. The actual display output is a window that is part of the whole image stored in the display memory. For example, with 128K of display memory, a 640x400 16-gray image can be stored. If the output display size is 320x240, then the whole image can be seen by changing display starting addresses through AUX[06] and [07], and AUX[08] and [09]. Note that a virtual screen can be produced on either a single or dual panel.

In 8-bit memory interface, if the Address Pitch Adjustment is not equal to zero, a virtual screen with a line length of (Line Byte Count +AUX[0D]) bytes is created, with the display reflecting the contents of a window (Line Byte Count+1) bytes wide. The position of the window on the virtual screen is determined by AUX[06] and [07], and AUX[08] and [09].

In 16-bit memory interface, if the Address Pitch Adjustment is not equal to zero, then a virtual screen with a line length of 2x(Line Byte Count +AUX[0D]) bytes is created, with the display reflecting the contents of a window 2x(Line Byte Count+1) bytes wide. The position of the window on the virtual screen is determined by AUX[06] and [07], and AUX[08] and [09].

## 5.1.2 Description

The SED1353 can be programmed to wrap memory offsets in such a way that the physical display behaves as a viewport into a much larger “virtual” memory space. This viewport can be panned and/or scrolled to display this larger memory space.

Referring to the figure below, a virtual image of 640x480 can be viewed by navigating the 320x240 viewport around the image by panning and scrolling.

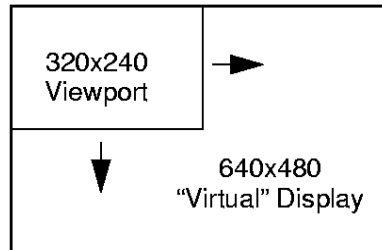

Figure 13: Moving A Viewport Inside A Virtual Display

To create a virtual display, the Address Pitch Adjustment Register must be programmed to indicate the horizontal size of the larger, “virtual” image stored in display memory. The Address Pitch Adjustment Register tells the SED1353 how many bytes or words of display memory are part of the nonvisible region of display memory (see Example 12).

**Example 12: Program the Address Pitch Adjustment Register to support a 16 color 640 x 480 virtual display on a 320 x 240 LCD panel; the Memory Interface is 16 bits.**

1. Initialize the SED1353 registers for a 320x240 panel.
2. Determine whether the Address Pitch Adjustment Register refers to bytes or words.  
Since the Memory Interface is set to 16 bits, the Address Pitch Adjustment Register refers to words.
3. Determine the number of pixels per unit referred to by the Address Pitch Adjustment Register.  
The Address Pitch Adjustment Register refers to units of words, so find the number of pixels per word.

$$\begin{aligned}
 16 \text{ colors} &\Rightarrow 4 \text{ bits per pixel} \\
 4 \text{ bits per pixel} &\Rightarrow 2 \text{ pixels per byte} \\
 \text{pixels per word} &= (\text{pixels per byte}) \times 2 = 2 \times 2 = 4 \text{ pixels per word}
 \end{aligned}$$

4. Calculate the number of pixels on a horizontal scan line not visible.

$$(\text{virtual display width in pixels}) - (\text{panel width in pixels}) = 640 - 320 = 320 \text{ hidden pixels}$$

Consequently on a screen update the SED1353 will show the first 320 of 640 pixels, and then ignore the remaining 320 pixels in order to reach the next scan line.

5. Program the Address Pitch Adjustment Register

$$\frac{\text{number of hidden horizontal pixels}}{\text{pixels per word}} = \frac{320}{4} = 80 \text{ words} = 50\text{h words}$$

Therefore AUX[0Dh] = 50h

6. To view the rest of the image refer to Section 5.5, “Panning and Scrolling” on page 52, keeping in mind that the horizontal width is 640 pixels, not 320.

## 5.2 Bitmaps and Text Displays

For the scope of this guide, a bitmap is a data structure which represents the image shown on the LCD. The bitmap includes the dimensions of the image, and the color or gray shade palette used to program the lookup table. Text is shown by creating a font, which in this example is a series of bitmaps, one bitmap per alphanumeric character.

**Example 13: Display the word “TEXT” on a 256 color 320 x 240 LCD panel; the Memory Interface is 16 bits.**

1. Define the font for the letters ‘T’, ‘E’, and ‘X’.  
Each character is 8x8 pixels, with at least one horizontal and vertical side left blank for spacing.

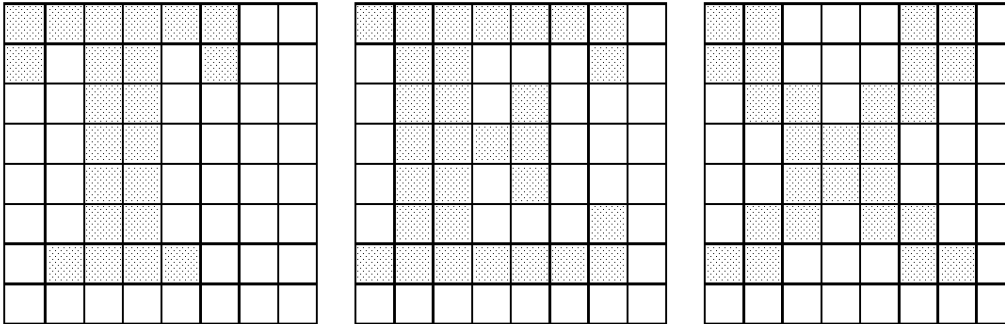

Figure 14: Font For The Message “TEXT”

2. Program the lookup table.  
See Example 3, “Initialize the Look-Up Table for 256 Colors (Bank 0 Only),” on page 23.
3. Calculate the display memory map.  
See Figure 11, “Memory Map Example For 320 x 240 LCD Panel With 256 Colors,” on page 39.
4. Write font to display memory.  
In a general purpose program the entire bitmapped font would be placed in an array. As characters are to be displayed, the program would choose the appropriate bitmap, select the proper position on the screen, and write to display memory. For this example assume that the program has already selected the proper bitmaps and the correct positions in display memory (there is a detailed programming example later in this guide; see Section 7.3, “Advanced Functions” on page 66).

Each highlighted pixel in the text bitmap will be shown at maximum intensity, which is pixel value 0FFh. The text, for simplicity, will be shown in the upper left corner of the screen. When the program has completed writing the pixels for the word “TEXT”, the display memory will have the data shown in Figure 15. In this figure the bytes are grouped within vertical lines.

Offset (hex)																	Offset (hex)							
0000	F	F	F	F	F	F	0	0	F	F	F	F	F	F	0	F	F	F	F	F	F	0	0	001F
0140	F	0	F	F	0	F	0	0	0	F	F	0	0	0	F	0	F	F	0	0	F	0	0	015F
0280	0	0	F	F	0	0	0	0	0	F	F	0	F	0	0	0	F	F	0	F	F	0	0	029F
03C0	0	0	F	F	0	0	0	0	0	F	F	F	F	0	0	0	F	F	F	0	0	0	0	03DF
0500	0	0	F	F	0	0	0	0	0	F	F	0	F	0	0	0	F	F	F	0	0	0	0	051F
0640	0	0	F	F	0	0	0	0	0	F	F	0	F	0	0	0	F	F	F	0	0	0	0	065F
0780	0	F	F	F	F	0	0	0	F	F	F	F	F	0	F	F	0	0	0	F	F	F	0	079F
08C0	0	0	0	0	0	0	0	0	0	0	0	0	0	0	0	0	0	0	0	0	0	0	0	08DF

Figure 15: Display Memory Contents For Message "Text" In 256 Color Mode

### 5.3 Mapping of Registers

The SED1353 has an internal set of 16-/8-bit read/write registers which configure it for various modes of operation. The registers can be accessed in two ways; Indexed Addressing and Direct Addressing.

**Note**

Refer to the *SED1353 Hardware Functional Specification* (Document number X18A-A-001-xx) for more information on the SED1353 registers.

#### 5.3.1 Indexed Mapping

This method requires only two sequential I/O address locations starting from the base I/O address. The base I/O address is determined by the power-on state of the SRAM data lines VD[4 through 12]. See "Summary of Configuration Options" in the *SED1353 Hardware Functional Specification*, Drawing Office No. X18A-A-001-xx.

The SDU1353B0C Evaluation Board uses three sequential I/O addresses which are defined as Index Address, Index Data, and Memory Banking. To access registers using this method, an Index Address must be written to the first I/O address location allowing data to be written/read to/from the second I/O address.

The Memory Banking port is specific to the SDU1353B0C implementation and is used to select one of two 64K display memory banks; a read from this port selects bank 0, and a write to this port selects bank 1. Note that the values read from or written to the Memory Banking port are not important.

**Example 14: Write 12h to register 08h on the SDU1353B0C evaluation board; the base port address is 310h, and indexed port mapping is used.**

1. Write 08h to the index register  
The index register is at base port address + 0 = 310h.

```
MOV DX, 310h
MOV AL, 08h
OUT DX, AL
```

2. Write 12h to the data register  
The data register is at base port address + 1 = 311h.

```
MOV DX, 311h
MOV AL, 12h
OUT DX, AL
```

### 5.3.2 Direct Mapping

This method of addressing requires 16 sequential I/O addresses starting from the base I/O address. The base I/O address is determined by the power-on state of the SRAM data lines VD[7 through 12]. See “*Summary of Configuration Options*” in the *SED1353 Hardware Functional Specification*, Drawing Office No. X18A-A-001-xx.

To access the internal 16 registers of the SED1353, simply perform I/O read/write functions to the absolute address as defined in the previous paragraph.

There is no memory banking available in direct addressing mode.

**Example 15: Write 12h to register 08h on the SDU1353B0C evaluation board; the base port address is 310h, and direct port mapping is used.**

1. Calculate the port address for register 08h.

$$\text{port address} = 310\text{h} + 8\text{h} = 318\text{h}$$

2. Write the value 12h to port address 318h.

```
MOV DX, 318h
MOV AL, 12h
OUT DX, AL
```

#### Note

The SDU1353B0C is normally configured for indexed mapping, not direct mapping. Refer to the *SDU1353B0C Evaluation Board User's Manual* for more information configuring the SDU1353B0C board for indexed or direct mapping.



## 5.4 Split Screen

This section describes how to create a split screen for both single and dual LCD panels. For single panel displays, the Screen 1 Display Line Count Registers are used. For dual panel displays, the Screen 2 Display Start Address Registers are used.

### Registers

AUX[0A] Screen 1 Display Line Count Register (LSB)							
I/O address = 1010b, Read/Write.							
Screen 1 Display Line Count Bit 7	Screen 1 Display Line Count Bit 6	Screen 1 Display Line Count Bit 5	Screen 1 Display Line Count Bit 4	Screen 1 Display Line Count Bit 3	Screen 1 Display Line Count Bit 2	Screen 1 Display Line Count Bit 1	Screen 1 Display Line Count Bit 0

AUX[0B] Screen 1 Display Line Count Register (MSB)							
I/O address = 1011b, Read/Write.							
n/a	n/a	n/a	n/a	n/a	n/a	Screen 1 Display Line Count Bit 9	Screen 1 Display Line Count Bit 8

AUX[0A] bits 7-0 Screen 1 Display Line Count Bits [9:0]

AUX[0B] bits 1-0 These bits are the eight LSB of a 10-bit value used to determine the number of lines displayed for screen 1. The remaining lines will automatically display from the screen 2 display start address. The 10-bit value programmed is the number of display lines -1.

This register is used to enable the split screen display feature (single panel only) where two different images can be displayed at the same time on one display.

For example; AUX[0A] = 20h for a 320x240 display system. The display will display  $20h+1 = 33$  lines on the upper part of the screen as dictated by the screen 1 display start address registers (AUX[06] and AUX[07]), and  $240 - 33 = 207$  lines will be displayed on the lower part of the screen as dictated by the screen 2 display start address registers (AUX[08] and AUX[09]).

Two different images can be displayed when using a dual panel configuration by changing the screen 2 display start address. However, by using this method screen 2 is limited to the lower half of the display.

This register is ignored in dual panel mode.

#### Note

See Section 4.2.2, "Display Start Address Registers" on page 37 for additional register descriptions.

### 5.4.1 Description

A split screen is generally considered as the presentation of two different images on the screen. Image 1 is shown on the top half and image 2 is shown on the bottom half of the screen. The system is *always* in split screen mode, on a single panel image 2 is displayed off screen; on a dual panel image 2 becomes the lower half of the panel.

### 5.4.2 Single Panel LCD

The following is the procedure to show a split screen image on a 16 color 320 x 240 single panel LCD. For this example the SDU1353B0C is used with the Memory Interface set to 16 bits (required for 128k of display memory). In addition, the two images shown on the split screen are each 320 x 240; only a portion of each image is shown.

1. Determine whether the Display Start Address Registers refer to bytes or words.  
Since the Memory Interface is set to 16 bits, the Display Start Address Registers refer to words. Note that when addresses refer to words, the image must be aligned in memory such that the beginning is found on a word boundary (the least significant bit of the memory address must be 0).
2. Calculate the number of bytes per scan line.

16 colors => 4 bits per pixel

4 bits per pixel => 2 pixels per byte

$$\text{number of bytes per scan line} = \frac{\text{pixels per scan line}}{\text{pixels per byte}} = \frac{320}{2} = 160 \text{ bytes per scan line} = 00A0h \text{ bytes per scan line}$$

3. Determine the display memory location for image 1.  
For simplicity, assign the beginning of display memory as the starting address of image 1 (see Figure 16). For the SDU1353B0C, this address is D000:0000h, bank 0.

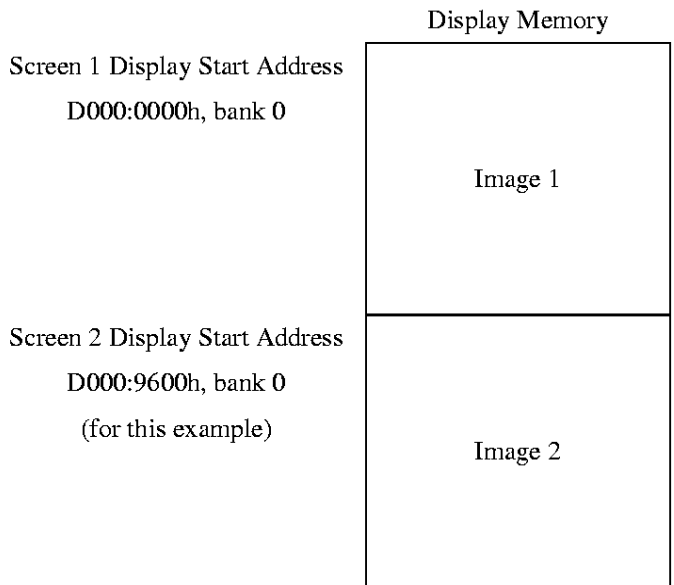

Figure 16: Memory Map For Split Screen

4. Program the Screen 1 Display Start Address Register to point to the beginning of image 1.  
Since image 1 is at the beginning of display memory, program the Screen 1 Display Start Address Register to 0000h.  
AUX[06h] = 00h  
AUX[07h] = 00h

5. Calculate the total number of bytes required for image 1.

$$(\text{bytes per scan line}) \times (\text{number of scan lines for image 1}) = 160 \times 240 = 38400 \text{ bytes} = 9600h \text{ bytes}$$

6. Determine the display memory location for image 2.  
Place image 2 immediately after image 1 (see Figure 16). Assign the starting address for image 2 as follows:

$$\begin{aligned}\text{image 2 address} &= (\text{base display memory address}) + (\text{size of image 1}) \\ &= \{\text{D000:0000h, bank 0}\} + \text{0000:9600h} \\ &= \{\text{D000:9600h, bank 0}\}\end{aligned}$$

Note that if the image 2 address is larger than D000:FFFFh, then switch to bank 1, reset the segment to D000h, and keep the offset. For example, if the image 2 address were {D001:9200h, bank 0}, then this address must be changed to {D000:9200h, bank 1}.

7. Program the Screen 2 Display Start Address Register to point to the beginning of image 2.  
Image 2 is placed right after image 1, as shown below:

$$\begin{aligned}\text{Screen 2 Display Start Address} &= \text{Screen 1 Display Start Address} + \frac{\text{size of image 1 in bytes}}{2 \text{ bytes per word}} \\ &= \text{0000h} + \frac{\text{9600h}}{2} = \text{4B00h}\end{aligned}$$

AUX[08h] = 00h

AUX[09h] = 4Bh

8. Program the Screen 1 Display Line Count Register.  
The Display Line Count Register indicates how many lines of the first screen should be shown *minus 1*. By changing the line count, image 2 appears to move up or down the display.

- If the line count is set to the maximum number of visible scan lines - 1, only image 1 is shown.

$$\text{visible scan lines} - 1 = 240 - 1 = 239 = \text{00EFh}$$

AUX[0Ah] = LSB of (visible scan lines - 1) = EFh

AUX[0Bh] = MSB of (visible scan lines - 1) = 00h

- If the line count is set to 0, then the first scan line of image 1 is shown followed by the first part of image 2. *It is not possible to show only image 2 by changing the line count. If only image 2 needs to be shown, reprogram the Screen 1 Display Start Address Registers to point to the beginning of image 2. Once both Screen 1 and 2 Display Start Address Registers point to the same image, the line count has no visible effect.*

AUX[0Ah] = 00h

AUX[0Bh] = 00h

- If the line count is set to 99, then the first 100 scan lines of image 1 are shown, following by the first part of image 2 (see Figure 17).  
AUX[0Ah] = 63h (99 decimal)  
AUX[0Bh] = 00h

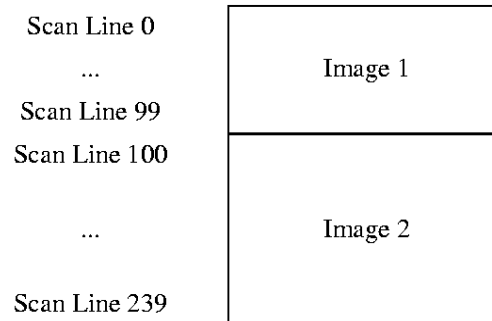

*Screen 1 Display Line Count Register = 99 lines*

*Figure 17: 320 x 240 Single Panel For Split Screen*

9. Write both image 1 and image 2 to their respective locations in display memory.

### 5.4.3 Dual Panel LCD

The following is the procedure to show a split screen image on a 4 gray shade 640 x 480 dual panel LCD. For this example the SDU1353B0C is used with the Memory Interface set to 16 bits (required for 128k of display memory). In addition, the two images shown on the split screen are each 640 x 240.

1. Determine whether the Display Start Address Registers refer to bytes or words.  
Since the Memory Interface is set to 16 bits, the Display Start Address Registers refer to words. Note that when addresses refer to words, the image must be aligned in memory such that the beginning is found on a word boundary (the least significant bit of the memory address must be 0).
2. Calculate the number of bytes per scan line.  
4 gray shades => 2 bits per pixel  
2 bits per pixel => 4 pixels per byte  
$$\text{number of bytes per scan line} = \frac{\text{pixels per scan line}}{\text{pixels per byte}} = \frac{640}{4} = 160 \text{ bytes per scan line} = 00A0h \text{ bytes per scan line}$$
3. Determine the display memory location for image 1.  
For simplicity, assign the beginning of display memory as the starting address of image 1 (see Figure 16). For the SDU1353B0C, this address is D000:0000h, bank 0.
4. Program the Screen 1 Display Start Address Register to point to the beginning of image 1.  
Since image 1 is at the beginning of display memory, program the Screen 1 Display Start Address Register to 0000h.  
AUX[06h] = 00h  
AUX[07h] = 00h
5. Calculate the total number of bytes required for image 1.

$$(\text{bytes per scan line}) \times (\text{number of scan lines for image 1}) = 160 \times 240 = 38400 \text{ bytes} = 9600h \text{ bytes}$$

6. Determine the display memory location for image 2.  
Place image 2 immediately after image 1 (see Figure 16). Assign the starting address for image 2 as follows:

$$\begin{aligned} \text{image 2 address} &= (\text{base display memory address}) + (\text{size of image 1}) \\ &= \{D000:0000h, \text{bank 0}\} + 0000:9600h \\ &= \{D000:9600h, \text{bank 0}\} \end{aligned}$$

Note that if the image 2 address is larger than D000:FFFFh, then switch to bank 1, reset the segment to D000h, and keep the offset. For example, if the image 2 address were {D001:9200h, bank 0}, then this address must be changed to {D000:9200h, bank 1}.

7. Program the Screen 2 Display Start Address Register to point to the beginning of image 2.  
Image 2 is placed right after image 1, as shown below:

$$\begin{aligned} \text{Screen 2 Display Start Address} &= \text{Screen 1 Display Start Address} + \frac{\text{size of image 1 in bytes}}{2 \text{ bytes per word}} \\ &= 0000h + \frac{9600h}{2} = 4B00h \end{aligned}$$

AUX[08h] = 00h

AUX[09h] = 4Bh

8. Write both image 1 and image 2 to their respective locations in display memory.

### Notes

When using a dual panel, the Screen 1 Display Line Count Register is ignored by the SED1353. Once the two Display Start Address Registers are programmed, the top panel will show the beginning of image 1, and the bottom panel will show the beginning of image 2 (see Figure 18).

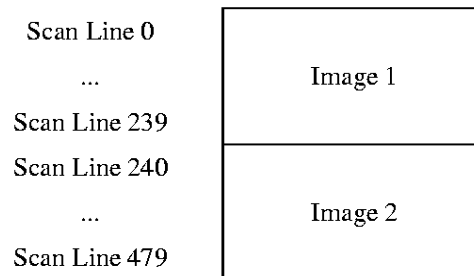

*Screen 1 Display Line Count is ignored;  
Image 1 always has half the total number of  
scan lines (240 in this example).*

Figure 18: 640 x 480 Dual Panel For Split Screen

Each image can be scrolled or panned by appropriate programming of the respective Display Start Address Registers. The following are some examples:

- To scroll image 1 up, the Screen 1 Start Address Register must point to the following scan line.

$$\text{Screen 1 Display Start Address} = \text{Screen 1 Display Start Address} + \frac{\text{number of bytes per scan line}}{2 \text{ bytes per word}}$$

AUX[06h] = LSB of Screen 1 Display Start Address  
AUX[07h] = MSB of Screen 1 Display Start Address

- To scroll image 2 down, the Screen 2 Start Address Register must point to the previous scan line.

$$\text{Screen 2 Display Start Address} = \text{Screen 2 Display Start Address} - \frac{\text{number of bytes per scan line}}{2 \text{ bytes per word}}$$

AUX[08h] = LSB of Screen 2 Display Start Address  
AUX[09h] = MSB of Screen 2 Display Start Address

- To pan image 1 to the right by a group of pixels, the Screen 1 Start Address Register must be increased by 1.

$$\text{Screen 1 Display Start Address} = \text{Screen 1 Display Start Address} + 1$$

AUX[06h] = LSB of Screen 1 Display Start Address  
AUX[07h] = MSB of Screen 1 Display Start Address  
See Section 5.5.2, “*Panning Right and Left*” on page 52 for more information.

- To pan image 2 to the left by a group of pixels, the Screen 2 Start Address Register must be decreased by 1.

$$\text{Screen 2 Display Start Address} = \text{Screen 2 Display Start Address} - 1$$

AUX[08h] = LSB of Screen 2 Display Start Address  
AUX[09h] = MSB of Screen 2 Display Start Address  
See Section 5.5.2, “*Panning Right and Left*” on page 52 for more information.

### 5.4.3.1 Displaying a Single Image on a Dual Panel

The following is the procedure to show a single image on a dual panel LCD. In this procedure the single image is broken into two smaller images; the first half of the image is placed on the top panel and the second half is placed on the bottom panel. For this example the SDU1353B0C is used with a 4 gray shade 640 x 480 dual panel LCD; the Memory Interface is set to 16 bits to support 128k of display memory.

- Determine whether the Display Start Address Registers refer to bytes or words.  
Since the Memory Interface is set to 16 bits, the Display Start Address Registers refer to words. Note that when addresses refer to words, the image must be aligned in memory such that the beginning is found on a word boundary (the least significant bit of the memory address must be 0).
- Calculate the number of bytes per scan line.

4 gray shades => 2 bits per pixel

2 bits per pixel => 4 pixels per byte

$$\text{number of bytes per scan line} = \frac{\text{pixels per scan line}}{\text{pixels per byte}} = \frac{640}{4} = 160 \text{ bytes per scan line} = 00A0h \text{ bytes per scan line}$$

- Determine the display memory location for the first half of the image.  
For simplicity, assign the beginning of display memory as the starting address of the image's first half (see Figure 19). For the SDU1353B0C, this address is D000:0000h, bank 0.

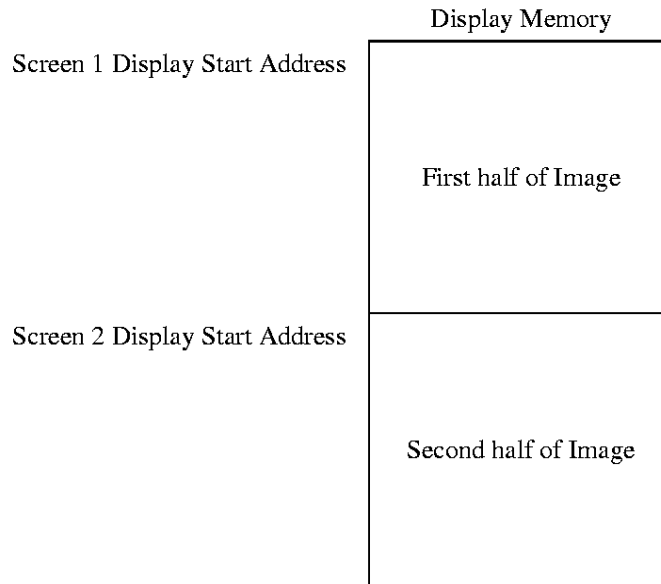

Figure 19: Memory Map For A Dual Panel Showing A Single Image

- Program the Screen 1 Display Start Address Register to point to the beginning of the first half of the image. Since the first half is at the beginning of display memory, program the Screen 1 Display Start Address Register to 0000h.  
AUX[06h] = 00h  
AUX[07h] = 00h

- Determine the size of the image's first half.

$$\text{vertical size of first half of image} = \text{vertical size of panel 1} = \frac{\text{number of scan lines in display}}{2} = \frac{480}{2} = 240 \text{ scan lines}$$

$$\text{size} = \frac{\text{display width in pixels}}{\text{pixels per byte}} \times (\text{number of scan lines in first half of image}) = \frac{640}{4} \times 240 = 38400 \text{ bytes} = 9600\text{h bytes}$$

- Determine the display memory location for the second half of the image.  
Place the second half of the image immediately after the first half (see Figure 19). Assign the starting address for the second half as follows:

$$\begin{aligned} \text{address of second half of image} &= (\text{base display memory address}) + (\text{size of first half of image}) \\ &= \{D000:0000\text{h, bank 0}\} + 0000:9600\text{h} \\ &= \{D000:9600\text{h, bank 0}\} \end{aligned}$$

Note that if the address of the second half of the image is larger than D000:FFFFh, then switch to bank 1, reset the segment to D000h, and keep the offset. For example, if the address of the second half of the image were {D001:9200h, bank 0}, then this address must be changed to {D000:9200h, bank 1}.

7. Program the Screen 2 Display Start Address Register to point to the beginning of the second half of the image. The second half of the image is placed right after the first half, as shown below:

$$\begin{aligned} \text{Screen 2 Display Start Address Register} &= \text{Screen 1 Display Start Address Register} + \frac{\text{size of first half of image in bytes}}{2 \text{ bytes per word}} \\ &= 0000\text{h} + \frac{9600\text{h}}{2} = 4B00\text{h} \end{aligned}$$

AUX[08h] = 00h  
AUX[09h] = 4Bh

8. Write both the first and second halves of the image to their respective locations in display memory.

## 5.5 Panning and Scrolling

Panning and scrolling are typically used to show an image which is too large to be shown completely on an LCD panel. Although the image is stored entirely in display memory, only a small portion is actually visible on the LCD panel. This visible portion is called the *viewport*; the user moves this viewport over different portions of the image by panning and scrolling. *Panning* moves the viewport right or left. *Scrolling* moves the viewport up or down.

### 5.5.1 Initialization

To pan and scroll over a large image, the SED1353 registers must first be initialized and the image written to display memory. To do so, initialize the registers as described in Section 2, “*INITIALIZING THE SED1353*” on page 10, but with the following exception: the Address Pitch Adjustment Register in the SED1353 must be set to create a virtual display; see Section 5.1, “*Virtual Displays*” on page 40 for more information.

### 5.5.2 Panning Right and Left

To pan to the right, increase the value in the Screen 1 Display Start Address Register. To pan to the left, decrease the value in the Screen 1 Display Start Address Register.

Note that the SED1353 can pan right or left by either 1, 2, 4, 8, or 16 pixels. This is because the Screen 1 Display Start Address Register refers to either bytes or words (see Section 4.2.1, “*SDU1353B0C Evaluation Board Display Memory*” on page 36), and a byte can represent 1, 2, 4, or 8 pixels, and so a word can represent 2, 4, 8, or 16 pixels; see Table 5-1 below:

Table 5-1: Smallest Number Of Pixels For Panning

Memory Interface	Colors/ Gray Levels	Pixels per Byte	Smallest Number of Pixels for Panning
8 bits	2	8	8
	4	4	4
	16	2	2
	256	1	1
16 bits	2	8	16
	4	4	8
	16	2	4
	256	1	2



### 5.5.3 Scrolling Up and Down

To scroll up, increase the value in the Screen 1 Display Start Address Register by the number of bytes in one *virtual* scan line. To scroll down, decrease the value in the Screen 1 Display Start Address Register by the number of bytes in one *virtual* scan line.

A virtual scan line is in reference to a virtual display, in which an image larger than the physical size of the LCD is stored. The number of bytes in a virtual scan line is the number of bytes required to store one horizontal line of pixels in the virtual image.

**Example 16: Scroll down one line for a 16 gray shade 640 x 200 virtual image using a 320 x 240 single panel LCD. The Memory Interface is set to 16 bits to support 128k of display memory. Also describe how to scroll in a dual panel LCD.**

1. Calculate the number of bytes in a virtual scan line.

$$\frac{\text{number of horizontal pixels in virtual image}}{\text{number of pixels per word}} = \frac{640 \text{ pixels per scan line}}{2 \text{ pixels per byte}} = 320 \text{ bytes per scan line}$$

2. Add the number of *words* in a virtual scan line to the Screen 1 Display Start Address Register. In this example the Screen 1 Display Start Address points to the beginning of the image.

$$\begin{aligned} \text{Screen 1 Display Start Address} &= \text{Screen 1 Display Start Address} + \frac{\text{number of bytes in a virtual scan line}}{2 \text{ bytes per word}} \\ &= 0000\text{h} + \frac{320}{2} \\ &= 00A0\text{h} \end{aligned}$$

3. Program the Screen 1 Display Start Address.

AUX[06h] = A0h  
AUX[07h] = 00h

4. This step is for dual panels only.

Add the number of *words* in a virtual scan line to the Screen 2 Display Start Address Register.

In this example the Screen 2 Display Start Address has previously been initialized as described in Section 5.4.3.1, “*Displaying a Single Image on a Dual Panel*” on page 50.

$$\text{Screen 2 Display Start Address} = \text{Screen 2 Display Start Address} + \frac{\text{number of bytes in a virtual scan line}}{2 \text{ bytes per word}}$$

5. This step is for dual panels only.

Program the Screen 2 Display Start Address.

AUX[08h] = least significant byte of “Screen 2 Display Start Address”  
AUX[09h] = most significant byte of “Screen 2 Display Start Address”

## 5.6 Power Saving

The following section introduces the power saving capabilities of the SED1353. A detailed description of the Power Save Register is provided, followed by a description of the power save modes.

### 5.6.1 Registers

Register bits discussed in this section are highlighted.

AUX[03] Mode Register 1							
I/O address = 0011b, Read/Write							
PS Bit 1	PS Bit 0	LCD Signal State	LUT Bypass	LCD Data Width Bit 1	BW / 256 colors	Color Mode	Line Byte Count Bit 8

bits 7-6

PS Bits [1:0]

Selects the Power Save Modes as shown in the following table. The PS bits [1:0] go low on RESET.

Table 5-2: Power Save Mode Selection

PS1	PS0	Mode Activated
0	0	Normal Operation
0	1	Power Save Mode 1
1	0	Power Save Mode 2
1	1	Reserved

For more details refer to “Power Save Modes” in the *SED1353 Hardware Functional Specification*, Drawing Office No. X18A-A-001-xx.

### 5.6.2 Power Save Modes

Two software-controlled Power Save Modes have been incorporated into the SED1353 to accommodate the important need for power reduction in the hand-held devices market. These modes can be enabled by setting the 2 Power Save bits (AUX[03h] bits 7-6).

The various settings are:

Table 5-3: Power Save Mode Selection

Bit 7	Bit 6	Mode Activated
0	0	Normal Operation
0	1	Power Save Mode 1
1	0	Power Save Mode 2
1	1	Reserved

#### 5.6.2.1 Power Save Mode 1

Power Save Mode 1 would typically be used when power savings are required and display memory accesses may occur. The disadvantage is that since the oscillator is running, this mode consumes more power than Power Save Mode 2.

#### 5.6.2.2 Power Save Mode 2

Power Save Mode 2 is typically used when display memory accesses would not occur.

### 5.6.2.3 Power Save Mode Function Summary

Table 5-4: Power Save Mode Function Summary

Function	Power Save Mode (PSM)			
	Normal (Active)	PSM1		PSM2
		State 1	State 2	
Display Active?	Yes	No	No	No
I/O Access Possible?	Yes	Yes	Yes	Yes
Memory Access Possible?	Yes	Yes	No	No
Sequence Controller Running?	Yes	No	No	No
Internal Oscillator Disabled?	No	No	No	Yes

#### Note

1. When programming the PS bits perform a read/modify/write operation so as not to destroy any other data in the register.
2. Refer to the programming example in Advanced Functions on page 66.

### 5.6.2.4 Programming to Enter Power Down Mode

If the LCDENB pin is used to control an external LCDBIAS power supply, the following sequence is recommended to prevent damage to the panel. Panel damage can occur if the LCDBIAS is present without active panel sync signals. Note the LCDENB pin is controlled by AUX[01h] bit 4 (LCDE).

1. Write '0' to bit 7 of AUX[01h] to turn off the display.
2. Write to bit 4 of AUX[01h] with value 'x' as appropriate to disable the specific power supply design. For the SDU1353B0C, write '0' to disable the power supply.
3. Wait until the LCDBIAS power supply reaches zero volts. This delay time is dependent upon the specific power supply design, as well as the display's electrical characteristics. For the SDU1353B0C, this time is about 0.5 seconds.
4. Enter power saving mode by writing the appropriate bits 7-6 of AUX[03h].

### 5.6.2.5 Programming to Exit Power Down Mode

When the LCDENB pin is used to control an external LCDBIAS power supply, the following sequence is recommended to exit power down mode. Note the LCDENB pin is controlled by AUX[01h] bit 4 (LCDE).

1. Exit power saving mode by writing 00b to bits 7-6 of AUX[03h].
2. Write to bit 4 of AUX[01h] with value 'x' as appropriate to enable the specific power supply design. For the SDU1353B0C, write '1' to enable the power supply. Note that no delay is required before applying power.
3. Write '1' to bit 7 of AUX[01h] to turn on the display.

## 6 IDENTIFYING THE SED1353

To identify the LCD controller upon power up / reset, perform the following steps:

1. Power up LCD controller.
2. Read AUX[0Eh], bits 5-4. Refer to Table 6-1 below to decode chip ID.

*Table 6-1: ID Bit Usage*

	Chip	Aux[0E]	
		bit 5	bit 4
Power On or RESET	SED1353F0A	0	0
	reserved	0	1
	SED1352F0B	1	0
	SED1352F0A	1	1

### Note

If the registers have already been initialized after power up, the ID bits in AUX[0Eh] cannot be used since these bits are also used for the RGB index. It is recommended to always store the chip ID immediately after power up and before any register initialization.

## 7 PROGRAMMING THE SED1353

The purpose of this section is to show how to program the SED1353 exercising the specific capabilities of this chip. A series of functions written in 'C' will be presented, each illustrating a basic feature of the SED1353. These functions are written for the SDU1353B0C evaluation board, and are combined under a menu-driven program called 1353DEMO.EXE.

### Note

The sample code will not run on a display larger than 320 x 240, and will use either 256 colors or 16 gray shades in most of the examples.

This program accepts the following command line options:

**1353DEMO t=n x=n y=n d=n i=n p=n [f=n] [/?]**

where:

- t** = SINGLE | DUAL
- x** = horizontal panel size in pixels from 1 to 320 (decimal)
- y** = vertical panel size in pixels from 1 to 240 (decimal)
- d** = COLOR | MONO
- i** = 4 | 8 (4 bit or 8 bit interface to panel)
- p** = 300 | 310...360 | 370 (port address in hex) (indexed I/O addressing selected by default)
- f** = 1 | 2 (format for color 8 bit panel interface)
- /?** = show this help screen

For example, if there is a 320 x 240 color single panel LCD, 8 bit interface, format 2, with a port address of 310h, type  
1353DEMO t=SINGLE x=320 y=240 d=COLOR i=8 p=310 f=2

When 1353DEMO is started, output will be sent to the standard output device. This output will present a menu of numbered options:

```
SED1353F0A/SDU1353B0C DEMO PROGRAM
Press 1 to read registers
Press 2 to show color/gray shade bar
Press 3 to show split screen
Press 4 to show panning and scrolling
Press 5 to start power saving
Press ESC to quit
```

*Figure 20: Display For 1353DEMO.EXE*

## 7.1 Main Loop Code

```
//-----
//
// FUNCTION: main()
//
// DESCRIPTION: Start of demo program.
//
// INPUTS: Command line arguments.
// RETURN VALUE: None.
//
//-----

void main(char argc, char **argv)
{
    int ch;

    CheckArguments(argc, argv);
    printf("Initializing\n");
    Initialize();
    SetDisplay(OFF);
    ClearLCDScreen();

    switch (GetID(PanelPortAddr))
    {
        case ID_1352FOA:
            printf("Detected SED1352FOA.\n\n");
            Quit();
            break;

        case ID_1352FOB:
            printf("Detected SED1352FOB.\n\n");
            Quit();
            break;

        case ID_1353:
            printf("Detected SED1353FOA.\n");
            break;

        default:
            printf("ERROR: Could not detect chip.\n\n");
            Quit();
            break;
    }

    ShowMenu();

    while ((ch = getch()) != ESC)
    {
        switch (ch)
        {
            case '1':
                ShowRegisters();
        }
    }
}
```

```
        break;

    case '2':
        GrayShadeBars();
        break;

    case '3':
        SplitScreen();
        break;

    case '4':
        PanScroll();
        break;

    case '5':
        PowerSaving();
        break;

    case ESC:
        exit(0);
    }
}
}
```

## 7.2 Initialization Code

```
//-----
//
// FUNCTION: Initialize()
//
// DESCRIPTION: Intialize SED1353 registers.
//
// INPUTS: This function looks at the followingl global variables to
//         determine the appropriate register settings:
//         PanelX, PanelY, PanelType
//
// OUTPUTS: The following global variables are changed:
//         PanelGrayLevel, BytesPerScanLine
//-----

void Initialize(void)
{
    static unsigned int val, val2;
    static unsigned int x;

    if (PanelD == PANEL_MONO)
        PanelGrayLevel = 16;
    else
        PanelGrayLevel = 256;

//-----

//
// Mode Register:
//   Display = OFF
//   Panel = SINGLE
//   Mask XSCL = NOT MASKED
//   LCDE = NOT ENABLED
//   Gray Shade/Color = 16 Gray Shades (bit is ignored for 256 colors)
//   LCD Data Width = 8 bit data transfer
//   Memory Interface = 16 bits
//   RAMS = Addressing for 8Kx8 SRAM
//
    val = 0x0C;

    if (Interface == 4)
        val &= 0xfb;    // Clear AUX[01] bit 2 so that Memory Interface = 4 bits

    if (PanelType == TYPE_DUAL)
        val |= 0x40;    // Set panel type to DUAL

    WriteRegister(1, val);    // Write to Mode Register

//-----
```



```

//
// Line Byte/Word Count Register
//
// Bits 0-7 are in AUX[2], Bit 8 is in AUX[3].
//
// Because the Memory Interface is set to 16 bits, the
// Line Byte/Word Count Register counts in words.
// To calculate the Line Byte Count for different numbers of
// gray shades/colors, use the following formula:
//
//          BitsPerPixel
//          ----- x Horizontal Resolution - 1
//          Memory Interface Width
//
switch (PanelGrayLevel)
{
case 2:
    val = (PanelX / 16) - 1;          // For black and white mode
    break;

case 4:
    val = (PanelX / 8) - 1;          // For 4 gray shades/colors
    break;

case 16:
    val = (PanelX / 4) - 1;          // For 16 gray shades/colors
    break;

case 256:
    val = (PanelX / 2) - 1;          // For 256 colors
    break;
}

WriteRegister(2, val & 0xff);        // Line Byte/Word Count Register

val2 = (val >> 8) & 0x01;

if (PanelD == PANEL_COLOR)
{
    val2 |= 0x06;                    // Select color mode and 256 colors

    if ((Interface == 8) && (PanelF == 2))
        val2 |= 0x08;                // Select format 2
}

WriteRegister(3, val2);              // Mode Register 1

//
// BytesPerScanLine is a global variable
//
switch (PanelGrayLevel)
{

```

```

case 2:
    BytesPerScanLine = (PanelX / 8);
    break;

case 4:
    BytesPerScanLine = (PanelX / 4);
    break;

case 16:
    BytesPerScanLine = (PanelX / 2);
    break;

case 256:
    BytesPerScanLine = PanelX;
    break;
}

//-----

//
// Total Display Line Count Register
// Screen 1 Display Line Count Register
//
// To show a full image on Screen 1, copy the Total Display Line Count
// into the Screen 1 Display Line Count.
//

//
// Old programs had previously assumed that all panels smaller
// than 400 lines use a 4 bit interface. However, newer panels
// which are less than 400 lines may use an 8 bit interface.
// Consequently this program must be told which interface to use.
//
// Set the Mask XSCL bit to MASKED (1) when using a 4 bit interface.
//
if (Interface == 4)
{
    val = ReadRegister(1);
    val &= 0xfb;    // Set LCD Data Width to 4 bit data transfer
    val |= 0x20;    // Set Mask XSCL to MASKED
    WriteRegister(1, val); // Write to Mode Register; LCD Data Width = 4 bits
}

val = PanelY;

//
// A dual panel LCD will, of course, have two panels. Each panel will
// show either the top or bottom half of the image, which is half of the
// vertical resolution.
//
if (PanelType == TYPE_DUAL)
    val /= 2;

```

```
--val;

WriteRegister(4, val & 0xff); // Write to Total Display Line Count Reg
WriteRegister(0x0a, val & 0xff); // Write to Screen 1 Display Line Count Reg
WriteRegister(5, (val >> 8) & 0x03); // Total Disp Line Cnt (MSB)/WF Count Reg
WriteRegister(0x0b, (val >> 8) & 0x03); // Scrn 1 Disp Line Count Reg (MSB)

//-----

//
// Set Screen 1 Display Start Address to beginning of video memory
//
WriteRegister(6, 0); // Write to Screen 1 Display Start Address Register
WriteRegister(7, 0);

//-----

//
// Screen 2 Display Start Address Register
//
// If using a dual panel, the Screen 2 Display Start Address must point
// to the second half of the image in video memory.
//
if (PanelType == TYPE_DUAL)
{
    val = (unsigned int) ((ReadRegister(3) & 0x01) << 8) | ReadRegister(2);
    ++val;

    val *= (PanelY / 2);
    WriteRegister(8, val & 0xff);
    WriteRegister(9, val >> 8);
}
else
{
    //
    // On a single panel, Screen 1 was programmed to show all of its
    // lines. Consequently Screen 2 will not be seen, and so the
    // Screen 2 Display Start Address will have no observable effect.
    // For convenience, set the screen 2 address to 0.
    //
    WriteRegister(8, 0);
    WriteRegister(9, 0);
}

//-----

//
// Set Horizontal Non-Display Period to 0 to use fixed default non-display period
//
WriteRegister(0x0c, 0);

//-----
```

```

//
// Set Address Pitch Adjustment to 0
//
WriteRegister(0x0d, 0); // Write to Address Pitch Adjustment Register

//-----

//
// Update Lookup Table for 16 gray shades/ 256 colors
//
if (PanelID == PANEL_MONO)
{
    for (x = 0; x < 16; ++x)
    {
        WriteRegister(0x0e, x);
        WriteRegister(0x0f, MonoLUT16[x]);
    }
}
else
{
    for (x = 0; x < 16; ++x)
    {
        WriteRegister(0x0e, x); // Auto-increment mode selected

        WriteRegister(0x0f, ColorLUT256Red[x]);
        WriteRegister(0x0f, ColorLUT256Green[x]);
        WriteRegister(0x0f, ColorLUT256Blue[x]);
    }
}

//-----

//
// Now that system is initialized, set DISPLAY ON and enable LCDE
//
val = ReadRegister(1);
val |= 0x90; // DISPLAY ON, LCDE enabled
WriteRegister(1, val);
}

//-----
//
// GetID()
//
// This function returns the Chip ID.
//
//-----

static unsigned char GetID(int PortAddr)
{
    static unsigned char ChipID;

```

```
ChipID = ID_NOT_DETECTED;

//
// If the chip was just powered up, and no registers have been initialized,
// then use the following code:
//
outp(PortAddr, 0x0e);

switch (inp(PortAddr+1) & 0x30)
{
  case 0x00:
    ChipID = ID_1353;
    break;

  case 0x20:
    ChipID = ID_1352F0B;
    break;

  case 0x30:
    ChipID = ID_1352F0A;
    break;

  default:
    ChipID = ID_NOT_DETECTED;
    break;
}

return (ChipID);
}
```

### 7.3 Advanced Functions

```

#define VIRTUAL_X      (360L)
#define VIRTUAL_Y      (360L)

//-----
//
// FUNCTION: ShowRegisters()
//
// DESCRIPTION: Shows the contents of the SED1353 registers.
//
// INPUTS: None.
// RETURN VALUE: None.
//
//-----

void ShowRegisters(void)
{
    static unsigned char x;
    static unsigned char red, green, blue;

    printf("SED1353 Registers: ");

    for (x = 0; x < 16; ++x)
        printf("%02X ", ReadRegister(x));

    printf("\nSED1353 Lookup Table: ");

    for (x = 0; x < 16; ++x)
    {
        WriteRegister(0x0e, x);

        red = ReadRegister(0x0f);
        green = ReadRegister(0x0f);
        blue = ReadRegister(0x0f);

        if (x % 7 == 0)
            printf("\n");

        printf("(%02X,%02X,%02X) ", red, green, blue);
    }

    ShowMenu();
}

//-----
//
// FUNCTION: GrayShadeBars()
//
// DESCRIPTION: Displays a series of vertical bars, each with a
//              different color/gray shade.
//              For color displays, bars are shown for 4, 16, and 256 colors.

```

```
//          For monochrome displays, bars are shown for black and white,
//          4, and 16 gray shades.
//
// INPUTS: None.
//
// RETURN VALUE: None.
//
//-----

void GrayShadeBars(void)
{
static unsigned int val, val2, x;
static unsigned char _far *pVideo;
static char Gray4[] = "Vertical Bars at 4 Gray Shades";
static char Color4[] = "Vertical Bars at 4 Colors";
static char Gray16[] = "Vertical Bars at 16 Gray Shades";
static char Color16[] = "Vertical Bars at 16 Colors";

static char *str;

printf("Displaying Vertical Bars\n");

Initialize();

SetDisplay(OFF);
ClearLCDScreen();

//
// Access memory banks
//
FP_SEG(pVideo) = 0xd000;
FP_OFF(pVideo) = 0x0000;

//-----

if (PanelD == PANEL_MONO)
{
//
// Select black and white mode
//
val = ReadRegister(3);
val |= 0x04;          // Set AUX[03] bit 2
val &= 0xfd;         // Clear AUX[03] bit 1
WriteRegister(3, val);

//
// Update Line Byte/Word Count register for black and white.
//
// Since black and white has 8 pixels per byte, there
```

```

// are ((x horizontal pixels)/8) bytes per scan line. This means that
// there are ((x horizontal pixels)/16) words per scan line.
//
// Since the Memory Interface is set to 16 bits, the Line Byte/Word Count
// refers to words.
//
val = (PanelX / 16) - 1;
BytesPerScanLine = (PanelX / 8);

WriteRegister(2, val & 0xff);           // Line Byte Count Register

val2 = ReadRegister(3);
val2 &= 0xfe;                          // Clear bit 0
val2 |= (val >> 8) & 0x01;
WriteRegister(3, val2);                // Mode Register 1

PanelGrayLevel = 2;
ShowVerticalBars(pVideo, 0);

//
// Show text. The lightest gray shade is set to PanelGrayLevel-1.
//
ShowText(pVideo, BANK0, "Vertical Bars for Black and White", PanelGrayLevel-1);
SetDisplay(ON);
Delay(2000);
}

//-----

SetDisplay(OFF);
ClearLCDScreen();

//
// Select 4 gray shades/colors
//
if (PanelD == PANEL_MONO)
{
    val = ReadRegister(1);
    val &= 0xf7;           // Clear AUX[01] bit 3
    WriteRegister(1, val);

    val = ReadRegister(3);
    val &= 0xf9;           // Clear AUX[03] bits 1 and 2
    WriteRegister(3, val);

    //
    // Update Lookup Table for 4 gray shades
    //
    for (x = 0; x < 16; ++x)
    {
        WriteRegister(0x0e, x);
        WriteRegister(0x0f, MonoLUT4[x]);
    }
}

```



```
    str = Gray4;
}
else // 4 colors
{
    val = ReadRegister(1);
    val &= 0xf7; // Clear AUX[01] bit 3
    WriteRegister(1, val);

    val = ReadRegister(3);
    val &= 0xfb; // Clear AUX[03] bit 2
    val |= 0x02; // Set AUX[03] bit 1
    WriteRegister(3, val);

    //
    // Update Lookup Table for 4 colors
    //
    for (x = 0; x < 16; ++x)
    {
        WriteRegister(0x0e, x);

        WriteRegister(0x0f, ColorLUT4Red[x]);
        WriteRegister(0x0f, ColorLUT4Green[x]);
        WriteRegister(0x0f, ColorLUT4Blue[x]);
    }

    str = Color4;
}

//
// Update Line Byte/Word Count register for 4 colors/gray shades
//
// Since 4 colors/gray shades corresponds to 4 pixels per byte, there
// are ((x horizontal pixels)/4) bytes per scan line. This means that
// there are ((x horizontal pixels)/8) words per scan line.
//
// Since the Memory Interface is set to 16 bits, the Line Byte/Word Count
// refers to words.
//
val = (PanelX / 8) - 1;
BytesPerScanLine = (PanelX / 4);

WriteRegister(2, val & 0xff); // Line Byte Count Register

val2 = ReadRegister(3);
val2 &= 0xfe; // Clear bit 0
val2 |= (val >> 8) & 0x01;
WriteRegister(3, val2); // Mode Register 1

PanelGrayLevel = 4;
ShowVerticalBars(pVideo, 0);

//
```

```

// Show text. The lightest color/gray shade is set to PanelGrayLevel-1.
//
ShowText(pVideo, BANK0, str, PanelGrayLevel-1);
ShowText(pVideo + BytesPerScanLine*8, BANK0, "BANK: 0", PanelGrayLevel-1);
SetDisplay(ON);
Delay(2000);

val = ReadRegister(0x0e);
val &= 0x3f;
val |= 0x40;
WriteRegister(0x0e, val);
ShowVerticalBars(pVideo, 0);

ShowText(pVideo, BANK0, str, PanelGrayLevel-1);
ShowText(pVideo + BytesPerScanLine*8, BANK0, "BANK: 1", PanelGrayLevel-1);
Delay(2000);

val &= 0x3f;
val |= 0x80;
WriteRegister(0x0e, val);
ShowVerticalBars(pVideo, 0);
ShowText(pVideo, BANK0, str, PanelGrayLevel-1);
ShowText(pVideo + BytesPerScanLine*8, BANK0, "BANK: 2", PanelGrayLevel-1);
Delay(2000);

val |= 0xc0;
WriteRegister(0x0e, val);
ShowVerticalBars(pVideo, 0);
ShowText(pVideo, BANK0, str, PanelGrayLevel-1);
ShowText(pVideo + BytesPerScanLine*8, BANK0, "BANK: 3", PanelGrayLevel-1);
Delay(2000);

//-----

SetDisplay(OFF);
ClearLCDScreen();

//
// Select 16 colors/gray shades
//
if (PanelD == PANEL_MONO)
{
    val = ReadRegister(1);
    val |= 0x08;          // Set AUX[01] bit 3
    WriteRegister(1, val);

    val = ReadRegister(3);
    val &= 0xf9;        // Clear AUX[03] bits 1 and 2
    WriteRegister(3, val);

    //
    // Update Lookup Table for 16 gray shades
    //

```

```
    for (x = 0; x < 16; ++x)
    {
        WriteRegister(0x0e, x);
        WriteRegister(0x0f, MonoLUT16[x]);
    }

    str = Gray16;
}
else // 16 colors
{
    val = ReadRegister(1);
    val |= 0x08; // Set AUX[01] bit 3
    WriteRegister(1, val);

    val = ReadRegister(3);
    val &= 0xfb; // Clear AUX[03] bit 2
    val |= 0x02; // Set AUX[03] bit 1
    WriteRegister(3, val);

    //
    // Update Lookup Table for 16 colors
    //
    for (x = 0; x < 16; ++x)
    {
        WriteRegister(0x0e, x);

        WriteRegister(0x0f, ColorLUT16Red[x]);
        WriteRegister(0x0f, ColorLUT16Green[x]);
        WriteRegister(0x0f, ColorLUT16Blue[x]);
    }

    str = Color16;
}

//
// Update Line Byte Count register for 16 colors/gray shades
//
// Since 16 colors/gray shades corresponds to 2 pixels per byte, there
// are ((x horizontal pixels)/2) bytes per scan line. This means that
// there are ((x horizontal pixels)/4) words per scan line.
//
// Since the Memory Interface is set to 16 bits, the Line Byte/Word Count
// refers to words.
//
val = (PanelX / 4) - 1;
BytesPerScanLine = (PanelX / 2);

WriteRegister(2, val & 0xff); // Line Byte Count Register

val2 = ReadRegister(3);
val2 &= 0xfe; // Clear bit 0
val2 |= (val >> 8) & 0x01;
WriteRegister(3, val2); // Mode Register 1
```

```

PanelGrayLevel = 16;
ShowVerticalBars(pVideo, 0);

//
// Show text. The lightest color/gray shade is set to PanelGrayLevel-1.
//
ShowText(pVideo, BANK0, str, PanelGrayLevel-1);
SetDisplay(ON);
Delay(2000);

//-----

if (PanelD == PANEL_COLOR)
{
    SetDisplay(OFF);
    ClearLCDScreen();

    //
    // Select 256 colors
    //
    val = ReadRegister(3);
    val |= 0x06;          // Set AUX[03] bits 1 and 2
    WriteRegister(3, val);

    //
    // Update Lookup Table for 256 colors
    //
    for (x = 0; x < 16; ++x)
    {
        WriteRegister(0x0e, x);

        WriteRegister(0x0f, ColorLUT256Red[x]);
        WriteRegister(0x0f, ColorLUT256Green[x]);
        WriteRegister(0x0f, ColorLUT256Blue[x]);
    }

    //
    // Update Line Byte/Word Count register for 256 colors
    //
    // Since 256 colors have one pixel per byte, there
    // are (x horizontal pixels) bytes per scan line. This means that
    // there are ((x horizontal pixels)/2) words per scan line.
    //
    // Since the Memory Interface is set to 16 bits, the Line Byte/Word Count
    // refers to words.
    //
    val = (PanelX / 2) - 1;
    BytesPerScanLine = PanelX;

    WriteRegister(2, val & 0xff);          // Line Byte Count Register

```

```

    val2 = ReadRegister(3);
    val2 &= 0xfe;                               // Clear bit 0
    val2 |= (val >> 8) & 0x01;
    WriteRegister(3, val2);                     // Mode Register 1

    PanelGrayLevel = 256;
    ShowVerticalBars(pVideo, 0);

    //
    // Show text. The lightest color is set to PanelGrayLevel-1.
    //
    ShowText(pVideo, BANK0, "Horizontal/Vertical Bars at 256 Colors", PanelGrayLevel-
1);
    SetDisplay(ON);
    Delay(2000);
}
else
    SetDisplay(ON);

ShowMenu();
}

//-----
//
// ShowText ()
//
// DESCRIPTION: Writes text to the LCD panel. Text must only contain
//              the letters A-Z, and the space character. All other
//              characters are replaced by spaces.
//
// NOTES: It is assumed that a pixel set to a value of 0 represents the
//        background color (black).
//
//-----

void ShowText(unsigned char _far *pVideoStart, unsigned char bank, char *str, int
color)
{
    static const unsigned char *pFont;
    static unsigned char _far *pVideoFirstColumn;
    static unsigned char _far *pVideo;
    static unsigned char ch;
    static unsigned int y, val, Video;
    static unsigned int count;

    //
    // Each letter in the font is 8 x 8 bits
    //
    #define MAX_FONT      97

    static const unsigned char font[MAX_FONT][8] =
        { { 0x00, 0x00, 0x00, 0x00, 0x00, 0x00, 0x00, 0x00 }, // (blank)

```

```

{ 0x30, 0x78, 0x78, 0x30, 0x30, 0x00, 0x30, 0x00 }, // !
{ 0x6C, 0x6C, 0x6C, 0x00, 0x00, 0x00, 0x00, 0x00 }, // "
{ 0x6C, 0x6C, 0xFE, 0x6C, 0xFE, 0x6C, 0x6C, 0x00 }, // #
{ 0x30, 0x7C, 0xC0, 0x78, 0x0C, 0xF8, 0x30, 0x00 }, // $
{ 0x00, 0xC6, 0xCC, 0x18, 0x30, 0x66, 0xC6, 0x00 }, // %
{ 0x38, 0x6C, 0x38, 0x76, 0xDC, 0xCC, 0x76, 0x00 }, // &
{ 0x60, 0x60, 0xC0, 0x00, 0x00, 0x00, 0x00, 0x00 }, // '
{ 0x18, 0x30, 0x60, 0x60, 0x60, 0x30, 0x18, 0x00 }, // (
{ 0x60, 0x30, 0x18, 0x18, 0x18, 0x30, 0x60, 0x00 }, // )
{ 0x00, 0x66, 0x3C, 0xFF, 0x3C, 0x66, 0x00, 0x00 }, // *
{ 0x00, 0x30, 0x30, 0xFC, 0x30, 0x30, 0x00, 0x00 }, // +
{ 0x00, 0x00, 0x00, 0x00, 0x00, 0x30, 0x30, 0x60 }, // ,
{ 0x00, 0x00, 0x00, 0xFC, 0x00, 0x00, 0x00, 0x00 }, // -
{ 0x00, 0x00, 0x00, 0x00, 0x00, 0x30, 0x30, 0x00 }, // .
{ 0x06, 0x0C, 0x18, 0x30, 0x60, 0xC0, 0x80, 0x00 }, // /
{ 0x7C, 0xC6, 0xCE, 0xDE, 0xF6, 0xE6, 0x7C, 0x00 }, // 0
{ 0x30, 0x70, 0x30, 0x30, 0x30, 0x30, 0xFC, 0x00 }, // 1
{ 0x78, 0xCC, 0x0C, 0x38, 0x60, 0xCC, 0xFC, 0x00 }, // 2
{ 0x78, 0xCC, 0x0C, 0x38, 0x0C, 0xCC, 0x78, 0x00 }, // 3
{ 0x1C, 0x3C, 0x6C, 0xCC, 0xFE, 0x0C, 0x1E, 0x00 }, // 4
{ 0xFC, 0xC0, 0xF8, 0x0C, 0x0C, 0xCC, 0x78, 0x00 }, // 5
{ 0x38, 0x60, 0xC0, 0xF8, 0xCC, 0xCC, 0x78, 0x00 }, // 6
{ 0xFC, 0xCC, 0x0C, 0x18, 0x30, 0x30, 0x30, 0x00 }, // 7
{ 0x78, 0xCC, 0xCC, 0x78, 0xCC, 0xCC, 0x78, 0x00 }, // 8
{ 0x78, 0xCC, 0xCC, 0x7C, 0x0C, 0x18, 0x70, 0x00 }, // 9
{ 0x00, 0x30, 0x30, 0x00, 0x00, 0x30, 0x30, 0x00 }, // :
{ 0x00, 0x30, 0x30, 0x00, 0x00, 0x30, 0x30, 0x60 }, // ;
{ 0x18, 0x30, 0x60, 0xC0, 0x60, 0x30, 0x18, 0x00 }, // <
{ 0x00, 0x00, 0xFC, 0x00, 0x00, 0xFC, 0x00, 0x00 }, // =
{ 0x60, 0x30, 0x18, 0x0C, 0x18, 0x30, 0x60, 0x00 }, // >
{ 0x78, 0xCC, 0x0C, 0x18, 0x30, 0x00, 0x30, 0x00 }, // ?
{ 0x7C, 0xC6, 0xDE, 0xDE, 0xDE, 0xC0, 0x78, 0x00 }, // @
{ 0x30, 0x78, 0xCC, 0xCC, 0xFC, 0xCC, 0xCC, 0x00 }, // A
{ 0xFC, 0x66, 0x66, 0x7C, 0x66, 0x66, 0xFC, 0x00 }, // B
{ 0x3C, 0x66, 0xC0, 0xC0, 0xC0, 0x66, 0x3C, 0x00 }, // C
{ 0xF8, 0x6C, 0x66, 0x66, 0x66, 0x6C, 0xF8, 0x00 }, // D
{ 0xFE, 0x62, 0x68, 0x78, 0x68, 0x62, 0xFE, 0x00 }, // E
{ 0xFE, 0x62, 0x68, 0x78, 0x68, 0x60, 0xF0, 0x00 }, // F
{ 0x3C, 0x66, 0xC0, 0xC0, 0xCE, 0x66, 0x3E, 0x00 }, // G
{ 0xCC, 0xCC, 0xCC, 0xFC, 0xCC, 0xCC, 0xCC, 0x00 }, // H
{ 0x78, 0x30, 0x30, 0x30, 0x30, 0x30, 0x78, 0x00 }, // I
{ 0x1E, 0x0C, 0x0C, 0x0C, 0xCC, 0xCC, 0x78, 0x00 }, // J
{ 0xE6, 0x66, 0x6C, 0x78, 0x6C, 0x66, 0xE6, 0x00 }, // K
{ 0xF0, 0x60, 0x60, 0x60, 0x62, 0x66, 0xFE, 0x00 }, // L
{ 0xC6, 0xEE, 0xFE, 0xFE, 0xD6, 0xC6, 0xC6, 0x00 }, // M
{ 0xC6, 0xE6, 0xF6, 0xDE, 0xCE, 0xC6, 0xC6, 0x00 }, // N
{ 0x38, 0x6C, 0xC6, 0xC6, 0xC6, 0x6C, 0x38, 0x00 }, // O
{ 0xFC, 0x66, 0x66, 0x7C, 0x60, 0x60, 0xF0, 0x00 }, // P
{ 0x78, 0xCC, 0xCC, 0xCC, 0xDC, 0x78, 0x1C, 0x00 }, // Q
{ 0xFC, 0x66, 0x66, 0x7C, 0x6C, 0x66, 0xE6, 0x00 }, // R
{ 0x78, 0xCC, 0xE0, 0x70, 0x1C, 0xCC, 0x78, 0x00 }, // S
{ 0xFC, 0xB4, 0x30, 0x30, 0x30, 0x30, 0x78, 0x00 }, // T
{ 0xCC, 0xCC, 0xCC, 0xCC, 0xCC, 0xCC, 0xFC, 0x00 }, // U

```

```

{ 0xCC, 0xCC, 0xCC, 0xCC, 0xCC, 0x78, 0x30, 0x00 }, // V
{ 0xC6, 0xC6, 0xC6, 0xD6, 0xFE, 0xEE, 0xC6, 0x00 }, // W
{ 0xC6, 0xC6, 0x6C, 0x38, 0x38, 0x6C, 0xC6, 0x00 }, // X
{ 0xCC, 0xCC, 0xCC, 0x78, 0x30, 0x30, 0x78, 0x00 }, // Y
{ 0xFE, 0xC6, 0x8C, 0x18, 0x32, 0x66, 0xFE, 0x00 }, // Z
{ 0x78, 0x60, 0x60, 0x60, 0x60, 0x60, 0x78, 0x00 }, // [
{ 0xC0, 0x60, 0x30, 0x18, 0x0C, 0x06, 0x02, 0x00 }, // (backslash)
{ 0x78, 0x18, 0x18, 0x18, 0x18, 0x18, 0x78, 0x00 }, // ]
{ 0x10, 0x38, 0x6C, 0xC6, 0x00, 0x00, 0x00, 0x00 }, // ^
{ 0x00, 0x00, 0x00, 0x00, 0x00, 0x00, 0x00, 0xFF }, // _
{ 0x30, 0x30, 0x18, 0x00, 0x00, 0x00, 0x00, 0x00 }, // `
{ 0x00, 0x00, 0x78, 0x0C, 0x7C, 0xCC, 0x76, 0x00 }, // a
{ 0xE0, 0x60, 0x60, 0x7C, 0x66, 0x66, 0xDC, 0x00 }, // b
{ 0x00, 0x00, 0x78, 0xCC, 0xC0, 0xCC, 0x78, 0x00 }, // c
{ 0x1C, 0x0C, 0x0C, 0x7C, 0xCC, 0xCC, 0x76, 0x00 }, // d
{ 0x00, 0x00, 0x78, 0xCC, 0xFC, 0xC0, 0x78, 0x00 }, // e
{ 0x38, 0x6C, 0x60, 0xF0, 0x60, 0x60, 0xF0, 0x00 }, // f
{ 0x00, 0x00, 0x76, 0xCC, 0xCC, 0x7C, 0x0C, 0xF8 }, // g
{ 0xE0, 0x60, 0x6C, 0x76, 0x66, 0x66, 0xE6, 0x00 }, // h
{ 0x30, 0x00, 0x70, 0x30, 0x30, 0x30, 0x78, 0x00 }, // i
{ 0x0C, 0x00, 0x0C, 0x0C, 0x0C, 0xCC, 0xCC, 0x78 }, // j
{ 0xE0, 0x60, 0x66, 0x6C, 0x78, 0x6C, 0xE6, 0x00 }, // k
{ 0x70, 0x30, 0x30, 0x30, 0x30, 0x30, 0x78, 0x00 }, // l
{ 0x00, 0x00, 0xCC, 0xFE, 0xFE, 0xD6, 0xC6, 0x00 }, // m
{ 0x00, 0x00, 0xF8, 0xCC, 0xCC, 0xCC, 0xCC, 0x00 }, // n
{ 0x00, 0x00, 0x78, 0xCC, 0xCC, 0xCC, 0x78, 0x00 }, // o
{ 0x00, 0x00, 0xDC, 0x66, 0x66, 0x7C, 0x60, 0xF0 }, // p
{ 0x00, 0x00, 0x76, 0xCC, 0xCC, 0x7C, 0x0C, 0x1E }, // q
{ 0x00, 0x00, 0xDC, 0x76, 0x66, 0x60, 0xF0, 0x00 }, // r
{ 0x00, 0x00, 0x7C, 0xC0, 0x78, 0x0C, 0xF8, 0x00 }, // s
{ 0x10, 0x30, 0x7C, 0x30, 0x30, 0x34, 0x18, 0x00 }, // t
{ 0x00, 0x00, 0xCC, 0xCC, 0xCC, 0xCC, 0x76, 0x00 }, // u
{ 0x00, 0x00, 0xCC, 0xCC, 0xCC, 0x78, 0x30, 0x00 }, // v
{ 0x00, 0x00, 0xC6, 0xD6, 0xFE, 0xFE, 0x6C, 0x00 }, // w
{ 0x00, 0x00, 0xC6, 0x6C, 0x38, 0x6C, 0xC6, 0x00 }, // x
{ 0x00, 0x00, 0xCC, 0xCC, 0xCC, 0x7C, 0x0C, 0xF8 }, // y
{ 0x00, 0x00, 0xFC, 0x98, 0x30, 0x64, 0xFC, 0x00 }, // z
{ 0x1C, 0x30, 0x30, 0xE0, 0x30, 0x30, 0x1C, 0x00 }, // {
{ 0x18, 0x18, 0x18, 0x00, 0x18, 0x18, 0x18, 0x00 }, // |
{ 0xE0, 0x30, 0x30, 0x1C, 0x30, 0x30, 0xE0, 0x00 }, // }
{ 0x76, 0xDC, 0x00, 0x00, 0x00, 0x00, 0x00, 0x00 }, // ~
{ 0x00, 0x10, 0x38, 0x6C, 0xC6, 0xC6, 0xFE, 0x00 }, // 127
{ 0xFF, 0xFF, 0xFF, 0xFF, 0xFF, 0xFF, 0xFF, 0xFF } }; // block char

```

```

pVideoFirstColumn = pVideoStart;
pVideo = pVideoFirstColumn;

//
// Select Memory Bank by reading or writing to port.
//
if (bank == 1)
    outp(PanelPortAddr+2, 0);

```

```
else
    inp(PanelPortAddr+2);

switch (PanelGrayLevel)
{
case 2:
    //
    // If there are 2 gray levels, there are 8 pixels/byte
    //
    color &= 0x01;

    while (*str != 0)
    {
        ch = *str++;

        if ((ch < ' ') || (ch - ' ' > MAX_FONT-1))
            ch = '.';

        pFont = &font[ch - ' '][0];

        for (y = 0; y < 8; ++y)
        {
            pVideo = pVideoFirstColumn;
            Video = 0;

            val = *pFont++;

            //
            // Since there are 2 gray shades, each bit in the font will be
            // represented in video memory as a one bit pixel.
            //
            if (val & 0x80)
                Video |= (color << 7);

            if (val & 0x40)
                Video |= (color << 6);

            if (val & 0x20)
                Video |= (color << 5);

            if (val & 0x10)
                Video |= (color << 4);

            if (val & 0x08)
                Video |= (color << 3);

            if (val & 0x04)
                Video |= (color << 2);

            if (val & 0x02)
                Video |= (color << 1);

            if (val & 0x01)
```



```
        Video |= color;

        *pVideo++ = (unsigned char) Video;
        CheckBank(pVideo, &bank);

        pVideoFirstColumn += BytesPerScanLine;
    }

    ++pVideoStart;    // Point to next character
    pVideoFirstColumn = pVideoStart;
}
break;

case 4:
    //
    // If there are 4 colors/gray levels, there are 4 pixels/byte
    //
    color &= 0x03;

    while (*str != 0)
    {
        ch = *str++;

        if ((ch < ' ') || (ch - ' ' > MAX_FONT-1))
            ch = '.';

        pFont = &font[ch - ' '][0];

        for (y = 0; y < 8; ++y)
        {
            pVideo = pVideoFirstColumn;
            Video = 0;

            val = *pFont++;

            //
            // Since there are 4 colors/gray shades, each bit in the font will be
            // represented in video memory as a two bit pixel.
            //
            if (val & 0x80)
                Video |= (color << 6);

            if (val & 0x40)
                Video |= (color << 4);

            if (val & 0x20)
                Video |= (color << 2);

            if (val & 0x10)
                Video |= color;

            *pVideo++ = (unsigned char) Video;
            CheckBank(pVideo, &bank);
```

```

    Video = 0;

    if (val & 0x08)
        Video |= (color << 6);

    if (val & 0x04)
        Video |= (color << 4);

    if (val & 0x02)
        Video |= (color << 2);

    if (val & 0x01)
        Video |= color;

    *pVideo++ = (unsigned char) Video;
    CheckBank(pVideo, &bank);

    pVideoFirstColumn += BytesPerScanLine;
}

pVideoStart += 2; // Point to next character
pVideoFirstColumn = pVideoStart;
}
break;

case 16:
    color &= 0x0f;

    while (*str != 0)
    {
        ch = *str++;

        if ((ch < ' ') || (ch - ' ' > MAX_FONT-1))
            ch = '.';

        pFont = &font[ch - ' '][0];

        for (y = 0; y < 8; ++y)
        {
            pVideo = pVideoFirstColumn;
            Video = 0;

            val = *pFont++;

            //
            // Since there are 16 colors/gray shades, each bit in the font will be
            // represented in video memory as a four bit pixel.
            //
            if (val & 0x80)
                Video |= (color << 4);

            if (val & 0x40)
                Video |= color;
        }
    }
}

```

```
    *pVideo++ = (unsigned char) Video;
    CheckBank(pVideo, &bank);
    Video = 0;

    if (val & 0x20)
        Video |= (color << 4);

    if (val & 0x10)
        Video |= color;

    *pVideo++ = (unsigned char) Video;
    CheckBank(pVideo, &bank);
    Video = 0;

    if (val & 0x08)
        Video |= (color << 4);

    if (val & 0x04)
        Video |= color;

    *pVideo++ = (unsigned char) Video;
    CheckBank(pVideo, &bank);
    Video = 0;

    if (val & 0x02)
        Video |= (color << 4);

    if (val & 0x01)
        Video |= color;

    *pVideo++ = (unsigned char) Video;
    CheckBank(pVideo, &bank);

    pVideoFirstColumn += BytesPerScanLine;
}

pVideoStart += 4; // Point to next character
pVideoFirstColumn = pVideoStart;
}
break;

case 256:
    while (*str != 0)
    {
        ch = *str++;

        if ((ch < ' ') || (ch - ' ' > MAX_FONT-1))
            ch = '.';

        pFont = &font[ch - ' '][0];

        for (y = 0; y < 8; ++y)
```

```

    {
    pVideo = pVideoFirstColumn;
    Video = 0;

    val = *pFont++;

    //
    // Since there are 256 colors, each bit in the font will be
    // represented in video memory as an 8 bit pixel.
    //
    for (count = 0; count < 8; ++count)
    {
        if (val & 0x80)
            Video = color;
        else
            Video = 0;

        *pVideo++ = (unsigned char) Video;
        CheckBank(pVideo, &bank);
        val <<= 1;
    }

    pVideoFirstColumn += BytesPerScanLine;
    }

    pVideoStart += 8; // Point to next character
    pVideoFirstColumn = pVideoStart;
    }
    break;
}

//-----
//
// FUNCTION: SplitScreen()
//
// DESCRIPTION: Show split screen.
//
// INPUTS: None.
// RETURN VALUE: None.
//-----

void SplitScreen(void)
{
    static unsigned char _far *pVideoImage1;
    static unsigned char _far *pVideoImage2;
    static unsigned long ImageSize;
    static unsigned int OriginalLineCount;
    static unsigned int val;
    static int MinLineCount;
    static unsigned int MaxVirtualScanLines;
    static unsigned char Image2Bank;

```

```
printf("Showing Split Screen\n");

Initialize();

SetDisplay(OFF);
ClearLCDScreen();

//
// Access memory banks
//
FP_SEG(pVideoImage1) = 0xd000;
FP_OFF(pVideoImage1) = 0x0000;

switch (PanelGrayLevel)
{
case 2:
    BytesPerScanLine = (PanelX / 8);
    break;

case 4:
    BytesPerScanLine = (PanelX / 4);
    break;

case 16:
    BytesPerScanLine = (PanelX / 2);
    break;

case 256:
    BytesPerScanLine = PanelX;
    break;
}

ShowVerticalBars(pVideoImage1, 0);

//
// Calculate starting video memory location for image 2 by finding the
// last location of image 1
//
ImageSize = (unsigned long) BytesPerScanLine * PanelY;

//
// Because the image size is limited to a maximum of 320 x 240, and there
// is 128k of video memory, there is enough memory available.
//
FP_SEG(pVideoImage2) = 0xd000;
FP_OFF(pVideoImage2) = (unsigned int) (ImageSize & 0xffff);

if (ImageSize & 0xffff0000)
    Image2Bank = BANK1;
```

```

else
    Image2Bank = BANK0;

ShowHorizontalBars(pVideoImage2, Image2Bank);

//
// Show text. The lightest color/gray shade is set to PanelGrayLevel-1.
//
ShowText(pVideoImage1, BANK0, "SPLIT SCREEN IMAGE ONE", PanelGrayLevel-1);
ShowText(pVideoImage2, Image2Bank, "SPLIT SCREEN IMAGE TWO", PanelGrayLevel-1);

//
// Set Screen 2 Display Start Address register to point to Image 2
//
// Adjust ImageSize to represent the size in words, not bytes.
// This is because the Memory Interface is set to 16 bits.
//
val = (unsigned int) (ImageSize / 2);

WriteRegister(8, (unsigned int) val & 0xff);
WriteRegister(9, (unsigned int) val >> 8);

SetDisplay(ON);

//
// If this is a dual panel, then the split screen has just been shown.
// Otherwise, set up the Screen 1 Display Line Count register for single
// panels.
//
if (PanelType == TYPE_SINGLE)
{
    OriginalLineCount =
        (unsigned int) ((ReadRegister(0x0b) & 0x03) << 8) | ReadRegister(0x0a);

    // Only for 128k of memory
    MaxVirtualScanLines = (unsigned int)
        ((unsigned long) 0x20000 / BytesPerScanLine);

    MinLineCount = OriginalLineCount -
        (MaxVirtualScanLines - OriginalLineCount) + 1;

    if (MinLineCount < 0)
        MinLineCount = 0;

    //
    // Scroll image 2 down
    //
    for (val = MinLineCount; val < OriginalLineCount; val += 1)

```

```
{
WriteRegister(0x0a, val & 0xff);          // Total Display Line Count
WriteRegister(0x0b, (val >> 8) & 0x03);  // Total Disp Line Cnt/WF Count

Delay(DELAY_SHORT);
}

//
// Scroll image 2 up
//
for (val = OriginalLineCount; val > (unsigned int) MinLineCount; val -= 1)
{
WriteRegister(0x0a, val & 0xff);          // Total Display Line Count
WriteRegister(0x0b, (val >> 8) & 0x03);  // Total Disp Line Cnt/WF Count

Delay(DELAY_SHORT);
}

val = MinLineCount;
WriteRegister(0x0a, val & 0xff);          // Total Display Line Count Reg
WriteRegister(0x0b, (val >> 8) & 0x03);  // Total Disp Line Cnt/WF Count

Delay(500);
}

ShowMenu();
}
```

---

```
void SetStartAddress(int x, int y)
{
int addr;

switch (PanelGrayLevel)
{
case 16:
addr = (unsigned int) ((x/2 + (VIRTUAL_X/2) * y)/2);
break;

case 256:
addr = (unsigned int) ((x + VIRTUAL_X * y)/2);
break;
}

WriteRegister(6, addr & 0xff);
WriteRegister(7, addr >> 8);
}
```

---

```
void PanScroll(void)
{
static unsigned int x, y;
```

```
static unsigned int MaxX, MaxY;
static unsigned int val, pitch;
static unsigned char _far *pVideo;
static unsigned char bank, color;

printf("Showing Panning and Scrolling\n");

Initialize();

SetDisplay(OFF);
ClearLCDScreen();

switch (PanelGrayLevel)
{
    case 16:
        pitch = (unsigned int) (((VIRTUAL_X / 2) - BytesPerScanLine) / 2);
        BytesPerScanLine = (VIRTUAL_X / 2);
        break;

    case 256:
        pitch = (unsigned int) ((VIRTUAL_X - BytesPerScanLine) / 2);
        BytesPerScanLine = VIRTUAL_X;
        break;
}

WriteRegister(0x0d, pitch);

//
// Access memory banks
//
FP_SEG(pVideo) = 0xd000;
FP_OFF(pVideo) = 0x0000;

//
// Display random blocks of data. To do so, a text character will be used.
// This character sets all pixels in a character region, so a block is
// shown at the specified gray shade.
//

// Seed the random number generator with current time
srand((unsigned) time(NULL));

for (x = 0; x < 300; ++x)
{
    if (((rand() * 2L) / RAND_MAX) == 1)
        bank = BANK0;
    else
        bank = BANK1;
}
```



```
FP_OFF(pVideo) = (unsigned int) ((rand() * 0xffffL) / RAND_MAX);
val = rand() % 50;

switch (PanelGrayLevel)
{
case 16:
    color = (unsigned char) (rand() % 16);
    break;

case 256:
    color = (unsigned char) (rand() % 256);
    break;
}

// The last character in the font table is a solid block character.
ShowText(pVideo, bank, "\x80", color);
}

ShowBorders();

//
// Move virtual display from (0, 0) to (MaxX, 0)
//
MaxX = (unsigned int) (VIRTUAL_X - PanelX);
MaxY = (unsigned int) (VIRTUAL_Y - PanelY);

SetDisplay(ON);

for (x = 0; x <= MaxX; ++x)
{
    SetStartAddress(x, 0);
    Delay(DELAY_SHORT);
}

for (y = 0; y <= MaxY; ++y)
{
    SetStartAddress(MaxX, y);
    Delay(DELAY_SHORT);
}

for (x = MaxX; x > 0; --x)
{
    SetStartAddress(x, MaxY);
    Delay(DELAY_SHORT);
}

for (y = MaxY; y > 0; --y)
{
    SetStartAddress(0, y);
    Delay(DELAY_SHORT);
}

SetStartAddress(0, 0);
```

```
ShowMenu();
}

//-----
//
// FUNCTION: PowerSaving()
//
// DESCRIPTION: Starts power saving mode 2.
//
// INPUTS: None.
// RETURN VALUE: None.
//-----

void PowerSaving(void)
{
static unsigned int val;

printf("Starting Power Saving\n");

//
// The following are the steps to enter a power save mode.
//

//
// Step 1: Turn off display
//
val = ReadRegister(1);
val &= 0x7f;
WriteRegister(1, val);

//
// Step 2: Disable LCDE (turn off LCD power supply).
//         For the SDU1353B0C, set LCDE bit to 0.
//
val = ReadRegister(1);
val &= 0xef;
WriteRegister(1, val);

//
// Step 2: Wait for LCD power supply to drop to zero volts
//         For the SDU1353B0C, wait about a half second.
//
Delay(500);

//
// Step 3: Enter Power Save Mode
//
val = ReadRegister(3);
val &= 0x3f;
val |= 0x80;
WriteRegister(3, val); // Set power saving mode 2
```

```
printf("Press any key to cancel power saving\n");
getch();

//
// The following are the steps to exit a power save mode.
//

//
// Step 1: Exit Power Save Mode
//
val = ReadRegister(3);
val &= 0x3f;
WriteRegister(3, val); // Cancel power saving mode 2

//
// Step 2: Enable LCDE (turn on LCD power supply).
//           For the SDU1353B0C, set LCDE bit to 1.
//
val = ReadRegister(1);
val |= 0x10;
WriteRegister(1, val);

//
// Step 3: Turn on display.
//
val = ReadRegister(1);
val |= 0x80;
WriteRegister(1, val);

ShowMenu();
}
```

## 8 GLOSSARY

<b>1353</b>	The SED1353 LCD controller chip.
<b>bank</b>	In reference to display memory banking, a bank is a 64k byte block of display memory. Bank 0 represents the first 64k bytes of display memory, and bank 1 represents the second 64k bytes.
<b>color</b>	A specific combination of red, green, and blue intensities.
<b>display memory</b>	Memory in which an image is stored for display by the SED1353.
<b>gray shade</b>	A specific combination of white and black colors. For example, a lighter gray shade has more white than black.
<b>LCD</b>	Liquid Crystal Display. The display device used by the SED1353.
<b>LCD controller</b>	The device used to control the LCD display. The SED1353 is an LCD controller.
<b>LUT</b>	Look-Up Table, or palette. The LUT treats the value of a pixel as an index into an array of colors or gray shades.
<b>panel</b>	The circuitry and viewable area of an LCD display which supports a single image. LCD displays may have one or two panels.
<b>panning</b>	The right or left movement of the viewport in a virtual display.
<b>pixel</b>	Picture Element. A pixel is seen as a dot on the display, and can be shown using one of several different colors or gray shades. Combining pixels in a group creates an image.
<b>power saving</b>	A means of reducing the power consumption of the SED1353.
<b>register</b>	A memory storage location to control a peripheral, such as the SED1353.
<b>scrolling</b>	The up and down movement of the viewport in a virtual display.
<b>SED1353</b>	The 1353 chip.
<b>SDU1353B0C</b>	The evaluation board for the SED1353. The SDU1353B0C is an ISA board for a PC-compatible computer.
<b>viewport</b>	The visible portion of a virtual display.
<b>virtual display</b>	An image, which is stored in display memory, that is larger than what the LCD display can show. A virtual display supports panning and scrolling.



## **SED1353 Dot Matrix Graphics LCD Controller**

# **1353SHOW.EXE Display Utility**

**Drawing Office No. X18A-B-001-02**

Copyright © 1997 S-MOS Systems Inc. All rights reserved.

This document, and any text derived, extracted or transmitted from it, is the sole property of S-MOS Systems Inc. and may not be used, copied, transmitted or otherwise made available to any other person, unless specifically allowed under license agreement with S-MOS Systems Inc. If furnished under a license, this document may be used and copied only in accordance with the terms of such license, and with the inclusion of this copyright notice. No title or ownership of the technology herein is transferred.

The information in this document is subject to change without notice and should not be construed as a commitment by S-MOS Systems Inc. This document does not necessarily describe any current planned or future product by S-MOS Systems Inc., nor does it represent any commitment to implement any such product.

**THIS PAGE LEFT BLANK**

## 1353SHOW.EXE DISPLAY UTILITY

1353SHOW is a utility used to load and display GIF images. It can also be used to demonstrate the split screen capabilities of the SED1353 by loading two images and vertically scrolling one image.

### Program Requirements

<b>Video Controller</b>	:	SED1353
<b>Display Type</b>	:	Up to 640x480 LCD
<b>BIOS</b>	:	Seiko Epson 1353BIOS version 1.xx or later
<b>DOS Program</b>	:	Yes
<b>DOS Version</b>	:	3.0 or greater
<b>Windows Program</b>	:	No
<b>Windows DOS Box</b>	:	Yes
<b>Windows DOS Full Screen</b>	:	Yes
<b>OS/2 DOS Full Screen</b>	:	Yes

### Installation

Copy the file **1353show.exe** to a directory that is in the DOS path on your hard drive.

### Usage

1353SHOW is invoked from the DOS command line as follows:

```
1353show [file1.gif] [file2.gif] [/i] [/k] [/v] [/?]
```

<b>Where:</b>	<code>file1.gif</code>	is the first screen image to be displayed.
	<code>file2.gif</code>	is the second screen image to be displayed.
	<code>/i</code>	inverts all displayed images (show as negative) - used for some monochrome panels (works in monochrome mode only).
	<code>/k</code>	exit the program and keep the image on the display - useful in batch file execution such as demonstrations.
	<code>/v</code>	verbose mode - useful to determine GIF information if it is not known.
	<code>/d</code>	leave the display on while loading image - useful for animation.
	<code>/?</code>	produces the usage message.

*Examples:* **1353show**

with no arguments will run the program in split screen mode. This will display two predefined images, with screen one displaying horizontal bars and screen two displaying vertical bars. Screen two may be scrolled up and down using the arrow, page up, page down, home and end keys.

**1353show file.gif**

displays the named GIF image.

**1353show file1.gif file2.gif**

displays the two named GIF images in a split screen. Screen two may be scrolled up and down using the arrow, page up, page down, home and end keys.

Pressing the ESC key will terminate the program.

## Comments

- 1353SHOW requires 1353BIOS.COM to be loaded prior to running.
- Split screen viewing is limited on dual panels. The view port is fixed in place at the top left of the bottom LCD panel. Panning and scrolling is still possible within the screen 2 view port.
- The size of screen two is determined by available memory and number of colors/gray shades. If there is insufficient memory for screen two 1353SHOW will not accept the two image files and will generate an error message.
- When loading two GIF images, it may take several seconds of apparent inactivity to load the second image into memory.
- The GIF format must be 2, 16 or 256 color, non-interlaced GIF89a format.
- 1353SHOW will clear the screen when the Esc key is pressed unless the /k switch is used in the command line.
- The file is loaded into the program at its image color depth (i.e., a 256 color image is initially displayed in 256 color mode, a 16 color image is initially displayed in 16 color mode).

## Program Messages

**ERROR: This program requires BIOS1353 to be loaded!**

The program 1353BIOS.COM must be run before 1353SHOW. Load 1353BIOS.COM and re-run 1353SHOW.EXE.

**File "filename" not found or cannot be opened for reading.**

The GIF file you are trying to display is not in your DOS path or not on your system.

**File is not GIF89a format.**

The GIF file contains an invalid format. 1353SHOW only supports GIF89a format.

**Insufficient video memory for second image.**

There is not enough video memory available to store both images.





## **SED1353 Dot Matrix Graphics LCD Controller**

# **1353VIRT.EXE Display Utility**

**Drawing Office No. X18A-B-002-02**

Copyright © 1997 S-MOS Systems Inc. All rights reserved.

This document, and any text derived, extracted or transmitted from it, is the sole property of S-MOS Systems Inc. and may not be used, copied, transmitted or otherwise made available to any other person, unless specifically allowed under license agreement with S-MOS Systems Inc. If furnished under a license, this document may be used and copied only in accordance with the terms of such license, and with the inclusion of this copyright notice. No title or ownership of the technology herein is transferred.

The information in this document is subject to change without notice and should not be construed as a commitment by S-MOS Systems Inc. This document does not necessarily describe any current planned or future product by S-MOS Systems Inc., nor does it represent any commitment to implement any such product.

**THIS PAGE LEFT BLANK**

## 1353VIRT.EXE DISPLAY UTILITY

1353VIRT.EXE demonstrates the virtual panning capabilities of the SED1353. Two images larger than the display resolution are loaded in display memory. 1353VIRT.EXE will then display, in a split screen, a portion of each complete image while providing panning capabilities using the arrow keys for navigation.

### Program Requirements

<b>Video Controller</b>	: SED1353
<b>Display Type</b>	: Up to 640x480 LCD
<b>BIOS</b>	: Seiko Epson 1353BIOS version 1.xx or later
<b>DOS Program</b>	: Yes
<b>DOS Version</b>	: 3.0 or greater
<b>Windows Program</b>	: No
<b>Windows DOS Box</b>	: Yes
<b>Windows DOS Full Screen</b>	: Yes
<b>OS/2 DOS Full Screen</b>	: Yes

### Installation

Copy the file **1353virt.exe** to a directory that is in the DOS path on your hard drive.

### Usage

1353VIRT is invoked from the DOS command line as follows:

```
1353virt g=n [/a] [/k] [/?]
```

Where: g is the number of gray shades/colors: **2, 4, 16** or **256**.  
/a automatically pan and scroll the image - useful for demonstrations.  
/k exit the program and keep the image on the display - useful in batch file execution for demonstrations.  
/? produces a usage message.

The program draws a test pattern of two images on the display. The user can navigate throughout either image using the numeric keypad. Use the arrow keys to pan and scroll the screen, Home to go to the top left, PG UP to go to the top right, End to go to the bottom left, Pg Dn to go to the bottom right, and 5 to go to the center of the image. Pressing Ctrl while using an arrow key steps the scroll or pan in smaller increments. Press the Num Lock key to allow navigation in the second image.

Holding down the Shift key while pressing either the up or down arrow will move the split up or down.

Pressing the ESC key terminates the program.

## Comments

- 1353VIRT requires 1353BIOS.COM to be loaded prior to running.

## Program Messages

**ERROR: This program requires 1353BIOS to be loaded!**

The program 1353BIOS.COM must be run before 1353VIRT.EXE. Load 1353BIOS.COM and then re-run 1353VIRT.EXE.



## **SED1353 Dot Matrix Graphics LCD Controller**

# **1353BIOS.COM Utility**

**Drawing Office No. X18A-B-003-02**

Copyright © 1995, 1997 S-MOS Systems Inc. All rights reserved.

This document, and any text derived, extracted or transmitted from it, is the sole property of S-MOS Systems Inc. and may not be used, copied, transmitted or otherwise made available to any other person, unless specifically allowed under license agreement with S-MOS Systems Inc. If furnished under a license, this document may be used and copied only in accordance with the terms of such license, and with the inclusion of this copyright notice. No title or ownership of the technology herein is transferred.

The information in this document is subject to change without notice and should not be construed as a commitment by S-MOS Systems Inc. This document does not necessarily describe any current planned or future product by S-MOS Systems Inc., nor does it represent any commitment to implement any such product.

**THIS PAGE LEFT BLANK**

## 1353BIOS.COM UTILITY

1353BIOS is a Terminate and Stay Resident (TSR) program which replaces and/or supplements the PC video interrupt INT 10h. This program provides text, scroll, and cursor functionality when no VGA BIOS is present. Although the SED1353 is not a VGA or EGA compatible controller, this program is supplied to give the user a familiar prompt. Within limits 1353BIOS simulates a VGA BIOS and will allow standard output functions to work. DOS programs such as Edlin, Format, Debug, and internal commands such as Copy, Ren, Mkdir, etc., should work. However, complex programs such as Edit, Qbasic, and Scandisk will not work. The standard output functions are handled by the VGA BIOS, if present.

### Program Requirements

<b>Video Controller</b>	: SED1353
<b>Display Type</b>	: Up to 640x480 LCD
<b>BIOS</b>	: None or any VGA
<b>DOS Program</b>	: Yes
<b>DOS Version</b>	: 3.0 or greater
<b>Windows Program</b>	: No
<b>Windows DOS Box</b>	: Yes
<b>Windows DOS Full Screen</b>	: Yes
<b>OS/2 DOS Full Screen</b>	: Yes

### Installation

Copy the files **1353bios.com** and **1353bios.ini** to a directory that is in the DOS path on your hard drive.

### Usage

1353BIOS.COM is run from the DOS command line.

The file 1353bios.ini is the initialization file for 1353bios.com and must reside in the same directory as 1353bios.com. This file contains the default run parameters for 1353bios.com. These parameters may be changed within the initialization file or for one time usage on the command line as follows:

```
1353bios d=n g=n i=n m=n p=n x=n y=n [/?] [f=n]
```

Where:	d	is panel type: <b>color</b> or <b>mono</b>
	g	is the number of colors/gray shades: <b>2, 4, 16</b> or <b>256</b>
	i	is the panel interface data width: <b>4, 8</b> or <b>16</b> bits
	m	is the memory size in K bytes: <b>64</b> or <b>128</b>
	p	is the port address in hex: <b>300 310...360 370</b>
	x	is the horizontal panel size in pixels (decimal)
	y	is the vertical panel size in lines (decimal)
	f	is the 8-bit color panel format: <b>1</b> or <b>2</b>
	?	produces a usage message

Note that the port address must be the same as the physical address set on the SDU1353 evaluation board.

*Example:*

```
1353BIOS d=color g=256 i=8 m=128 p=310 t=single x=320 y=240 f=2
```

## Comments

- 1353BIOS can be used in conjunction with a Monochrome Display Adapter (mono) card. The standard DOS command MODE MONO will switch to the monochrome card and the DOS command MODE CO80 will switch to the LCD panel.
- 1353BIOS emulates mode 3, but any program that attempts to write directly to video memory, bypassing the video BIOS, will not display correctly.
- 1353BIOS can be used in conjunction with a VGA BIOS. In this case all TTY output will be displayed on the VGA monitor.
- When the SED1353 video memory is specified as 64K bytes, the SED1353 video memory will reside at D000h to DFFFh. For 128K bytes of SED1353 video memory, the memory will reside at C000h to DFFFh.

## Program Messages

**ERROR: panels greater than 640 pixels not supported.**

More than 640 horizontal pixels has been specified for the panel in the command line.

**ERROR: panels greater than 480 lines not supported.**

More than 480 vertical lines has been specified for the panel in the command line.

**ERROR: invalid port specified.**

The port address (**p**) must be specified in the format 3x0 in the command line. The range is 300h to 370h in 10h increments.

**ERROR: not enough memory for panel.**

The panel specified is too large to run in 16 gray shades mode. Select 4 gray shades instead.

**ERROR: Video memory and VGA BIOS memory conflict.**

Both the SED1353 video memory and the VGA BIOS are trying to use the memory at location C000h to CFFFh.

**ERROR: only 64k or 128k memory allowed.**

An invalid value has been specified for memory size (**m**) on the command line.





## **SED1353 Dot Matrix Graphics LCD Controller**

# **1353MODE.EXE Display Utility**

**Drawing Office No. X18A-B-004-02**

Copyright © 1997 S-MOS Systems Inc. All rights reserved.

This document, and any text derived, extracted or transmitted from it, is the sole property of S-MOS Systems Inc. and may not be used, copied, transmitted or otherwise made available to any other person, unless specifically allowed under license agreement with S-MOS Systems Inc. If furnished under a license, this document may be used and copied only in accordance with the terms of such license, and with the inclusion of this copyright notice. No title or ownership of the technology herein is transferred.

The information in this document is subject to change without notice and should not be construed as a commitment by S-MOS Systems Inc. This document does not necessarily describe any current planned or future product by S-MOS Systems Inc., nor does it represent any commitment to implement any such product.

**THIS PAGE LEFT BLANK**

## 1353MODE.EXE DISPLAY UTILITY

1353MODE is a menu driven display utility for the SED1353 which demonstrates the color /gray shades as well as available palettes. For 128K bytes of display memory either 4, 16 or 256 colors/gray shades are available.

### Program Requirements

<b>Video Controller</b>	:	SED1353
<b>Display Type</b>	:	Up to 640x480 LCD
<b>BIOS</b>	:	Seiko Epson 1353BIOS version 1.x or later
<b>DOS Program</b>	:	Yes
<b>DOS Version</b>	:	3.0 or greater
<b>Windows Program</b>	:	No
<b>Windows DOS Box</b>	:	Yes
<b>Windows DOS Full Screen</b>	:	Yes
<b>OS/2 DOS Full Screen</b>	:	Yes

### Installation

Copy the file **1353mode.exe** to a directory that is in the DOS path on your hard drive.

### Usage

1353MODE is invoked from the DOS command line as follows:

```
1353mode g=n [/?] [/d] [/k]
```

Where: **g** is the number of colors /gray shades: **2, 4, 16** or **256**  
**/?** produces a usage message.  
**/d** inhibits display writes on startup - useful for examining the L.U.T. of a previously loaded image.  
**/k** exit the program and keep the image on the display - useful for batch file execution for demonstrations.

1353MODE displays a default color/gray shade pattern as a series of vertical or horizontal bars. The pattern, number of colors/gray shades and current palette may be modified by the user when possible. Instructions to modify these options appear when available.

An image other than the default one may be used as follows:

1. run **1353bios.com** if it is not already loaded
2. load an image into the video buffer with 1353show.exe  
**1353show file.gif /k**
3. load **1353mode /d**

The Look-Up Table (L.U.T.) of the image file displayed may now be manipulated by the user.

Pressing the ESC key terminates the program and restores the original 1353BIOS settings.

## Comments

- 1353MODE requires 1353BIOS.COM to be loaded prior to running.

## Program Messages

**ERROR: This program requires 1353BIOS to be loaded!**

The program 1353BIOS.COM must be run before 1353MODE. Load 1353BIOS.COM and then re-run 1353MODE.EXE.



## **SED1353 Dot Matrix Graphics LCD Controller**

# **1353PD.EXE Power Down Utility**

**Drawing Office No. X18A-B-005-02**

Copyright © 1996, 1997 S-MOS Systems Inc. All rights reserved.

This document, and any text derived, extracted or transmitted from it, is the sole property of S-MOS Systems Inc. and may not be used, copied, transmitted or otherwise made available to any other person, unless specifically allowed under license agreement with S-MOS Systems Inc. If furnished under a license, this document may be used and copied only in accordance with the terms of such license, and with the inclusion of this copyright notice. No title or ownership of the technology herein is transferred.

The information in this document is subject to change without notice and should not be construed as a commitment by S-MOS Systems Inc. This document does not necessarily describe any current planned or future product by S-MOS Systems Inc., nor does it represent any commitment to implement any such product.

**THIS PAGE LEFT BLANK**

## 1353PD.EXE POWER DOWN UTILITY

1353PD is an OEM utility program for setting power down modes in the SED1353 LCD Display Controller that supports the SOLLEX Super VGA Standard video BIOS extensions. It provides a simple method for setting power modes during power consumption testing.

### Program Requirements

<b>Video Controller</b>	: SED1353
<b>Display Type</b>	: Up to 640x480 LCD
<b>BIOS</b>	: Seiko Epson 1353BIOS version 1.xx or later
<b>DOS Program</b>	: Yes
<b>DOS Version</b>	: 3.0 or greater
<b>Windows Program</b>	: No
<b>Windows DOS Box</b>	: Yes
<b>Windows DOS Full Screen</b>	: Yes
<b>OS/2 DOS Full Screen</b>	: Yes

### Installation

Copy the file **1353pd.exe** to a directory that is in the DOS path on your hard drive.

### Usage

1353PD is run from the DOS command line as follows:

```
1353pd ModeNumber
```

Where: `ModeNumber` is a decimal number (0, 1, or 2) for the desired power down mode.

*Example:* typing the following command line activates power down mode 2:

```
1353pd 2 <ENTER>
```

Output from the program can be redirected to an external DOS device such as a terminal attached to the serial port such as COM1 as shown below:

```
1353pd 2 > com1 <ENTER>
```

Striking any key will set mode state 0 (no power down).

## Comments

- 1353PD.EXE requires 1353BIOS.COM to be loaded prior to running.
- The following power modes are supported:
  - Mode 0            Mode 0 operates at full power.
  - Mode 1 or 2       SED1353 will engage power down mode 1 or 2. The SED1353 Look-Up Table will be disabled and all LCD signals are forced low.

## Program Messages

**Power Down Mode xx is set.**

The power down mode xx has been set. This message may not be visible if the active display controller is the SED1353.

**ERROR: Cannot set power mode xx!**

1353PD.EXE cannot set the power down mode requested - either 1353BIOS.COM is not loaded or the power down mode number exceeds 2.

**ERROR: This program requires 1353BIOS to be loaded!**

The program 1353BIOS.COM must be run before 1353PD. Load 1353BIOS and re-run 1353PD.EXE.





## **SED1353 Dot Matrix Graphics LCD Controller**

# **1353READ.EXE Diagnostic Utility**

**Drawing Office No. X18A-B-006-02**

Copyright © 1997 S-MOS Systems Inc. All rights reserved.

This document, and any text derived, extracted or transmitted from it, is the sole property of S-MOS Systems Inc. and may not be used, copied, transmitted or otherwise made available to any other person, unless specifically allowed under license agreement with S-MOS Systems Inc. If furnished under a license, this document may be used and copied only in accordance with the terms of such license, and with the inclusion of this copyright notice. No title or ownership of the technology herein is transferred.

The information in this document is subject to change without notice and should not be construed as a commitment by S-MOS Systems Inc. This document does not necessarily describe any current planned or future product by S-MOS Systems Inc., nor does it represent any commitment to implement any such product.

**THIS PAGE LEFT BLANK**

## 1353READ.EXE DIAGNOSTIC UTILITY

1353READ is an OEM utility program which enables the user to read the SED1353 register contents. It is a useful utility for OEMs wishing to submit a problem report for the video controller. If run with 1353BIOS loaded, it will try to interpret the BIOS settings.

### Program Requirements

<b>Video Controller</b>	: SED1353
<b>Display Type</b>	: Up to 640x480 LCD
<b>BIOS</b>	: Seiko Epson 1353BIOS.COM (optional)
<b>DOS Program</b>	: Yes
<b>DOS Version</b>	: 3.0 or greater
<b>Windows Program</b>	: No
<b>Windows DOS Box</b>	: Yes
<b>Windows DOS Full Screen</b>	: Yes
<b>OS/2 DOS Full Screen</b>	: Yes

#### Note

1353READ uses "stdout" calls and may be redirected to a file or piped to a DOS filter such as MORE.COM.

### Installation

Copy the file **1353read.exe** to a directory that is in the DOS path on your hard drive.

### Usage

From DOS prompt, type the following:

**1353read [p=n] [/?]**

Where: **1353read** without any argument will read the SED1353 registers, including the palettes.  
**p** is the SED1353 port address in hex (e.g. 310).  
**/?** produces a usage message.

*Example:* to generate a report, simply type  
**1353read [port] > report.txt**

and the information which 1353READ obtains will be stored in the file report.txt.

## Comments

- It is not necessary to specify a port address if 1353BIOS has previously been loaded.
- 1353READ will search for 1353BIOS.COM. If this program is found the port address reported by 1353BIOS will be used. If the port address is specified on the 1353READ command line the two port addresses are compared and if different an error message is generated.
- 1353READ will accept any port address, however, the SDU1353B0C can only be configured to an address in the range of 300h through 370h.

## Program Messages

**ERROR: 1353 registers not responding at port address [port].**

1353READ has not found an SED1353 at the port address specified. Check the command line port setting for 1353BIOS and/or 1353READ to ensure it is correct and re-run the program.

**ERROR: 1353READ requires a port address.**

1353READ has not detected 1353BIOS.COM to obtain the port address and no port address was specified on the command line. Either specify a port address on the 1353READ command line or run 1353BIOS.COM prior to running 1353READ.

**ERROR: 1353BIOS reports a port address of [port], which is different from the specified port address of [port].**

The port address entered for 1353READ is different than the one entered for 1353BIOS.COM. Specify the same port address on the 1353READ command line as the one in 1353BIOS.COM and the physical address of the SDU1353 evaluation board and re-run the program.

**WARNING: 1353BIOS state is out of sync with SED1353 registers.**

One or more of the following command line items reported by 1353BIOS does not match the values found in the SED1353 registers; horizontal panel size, vertical panel size, number of colors/gray shades, or panel type (single or dual).



## **SED1353 Dot Matrix Graphics LCD Controller**

# **SDU1353B0C Rev. 1.0 Evaluation Board User's Manual**

**Drawing Office No. X18A-G-007-02**

Copyright © 1997 S-MOS Systems Inc. All rights reserved.

This document, and any text derived, extracted or transmitted from it, is the sole property of S-MOS Systems Inc. and may not be used, copied, transmitted or otherwise made available to any other person, unless specifically allowed under license agreement with S-MOS Systems Inc. If furnished under a license, this document may be used and copied only in accordance with the terms of such license, and with the inclusion of this copyright notice. No title or ownership of the technology herein is transferred.

The information in this document is subject to change without notice and should not be construed as a commitment by S-MOS Systems Inc. This document does not necessarily describe any current planned or future product by S-MOS Systems Inc., nor does it represent any commitment to implement any such product.

**THIS PAGE LEFT BLANK**

## TABLE OF CONTENTS

<b>1</b>	<b>SDU1353B0C REV 1.0 EVALUATION BOARD</b>	<b>.7</b>
1.1	Features	.7
<b>2</b>	<b>INSTALLATION AND CONFIGURATION</b>	<b>.8</b>
<b>3</b>	<b>TECHNICAL DESCRIPTION</b>	<b>13</b>
3.1	ISA Bus Support	13
3.2	Non-ISA Bus Support	14
3.3	SRAM Support	14
3.4	Monochrome LCD Support	14
3.5	Color LCD Support	15
3.6	Power Save Modes	15
3.7	Adjustable LCD Panel Negative Power Supply	15
3.8	Adjustable LCD Panel Positive Power Supply	15
3.9	Crystal Support	16
3.10	Oscillator Support	16
3.11	CPU/Bus Interface Header Strips	16
3.12	Schematic Notes	16
<b>Appendix A</b>	<b>Parts List</b>	<b>17</b>
<b>Appendix B</b>	<b>SDU1353B0C Rev. 1.0 Schematic Diagrams</b>	<b>18</b>

**THIS PAGE LEFT BLANK**



## LIST OF TABLES

Table 2-1: Configuration DIP Switch Settings . . . . .	8
Table 2-2: I/O Mapping Example . . . . .	8
Table 2-3: Decoding Jumper Setting . . . . .	9
Table 2-4: LCD Signal Connector J1 Pinout . . . . .	10
Table 2-5: CPU/BUS Connector H1 Pinout . . . . .	11
Table 2-6: CPU/BUS Connector H2 Pinout . . . . .	12

## LIST OF FIGURES

Figure 1: SDU1353B0C Rev. 1.0 Schematic Diagram (1 of 7) . . . . .	18
Figure 2: SDU1353B0C Rev. 1.0 Schematic Diagram (2 of 7) . . . . .	19
Figure 3: SDU1353B0C Rev. 1.0 Schematic Diagram (3 of 7) . . . . .	20
Figure 4: SDU1353B0C Rev. 1.0 Schematic Diagram (4 of 7) . . . . .	21
Figure 5: SDU1353B0C Rev. 1.0 Schematic Diagram (5 of 7) . . . . .	22
Figure 6: SDU1353B0C Rev. 1.0 Schematic Diagram (6 of 7) . . . . .	23
Figure 7: SDU1353B0C Rev. 1.0 Schematic Diagram (7 of 7) . . . . .	24

**THIS PAGE LEFT BLANK**

# 1 SDU1353B0C REV 1.0 EVALUATION BOARD

This manual reflects the use of the SDU1353B0C Rev 1.0 evaluation board in conjunction with the SED1353F0A LCD Controller. All appropriate components are surface-mount to reduce cost and minimize board space.

## 1.1 Features

- 100 pin QFP5 package
- SMD technology for all appropriate devices
- 4/8-bit Monochrome STN LCD display support
- 4/8/16-bit Color STN LCD display support
- 8/16-bit ISA Bus support
- 5V operation
- Two terminal crystal support (up to 25.0MHz)
- Oscillator support
- 16-bit wide, 128K bytes SRAM support
- Configuration Options
- Support for Software Power Save Modes
- On-board adjustable LCD BIAS negative power supply
- On-board adjustable LCD BIAS positive power supply
- CPU/Bus Interface Header strips for Non-ISA Bus Support

## 2 INSTALLATION AND CONFIGURATION

The SED1353F0A uses the display memory data lines (VD[15:0]) as configuration inputs which are read on power-up. For the purpose of this design, most of these configuration inputs have been factory set and therefore are not configurable. An eight position DIP switch is provided for the selection of the following:

Table 2-1: Configuration DIP Switch Settings

Switch	Signal	Closed	Open
SW1-1	VD0	16-bit ISA Bus interface	8-bit ISA Bus interface
SW1-2	VD1	Direct-mapping I/O	Indexed I/O
SW1-3	VD2	M68K CPU Interface	ISA Bus Interface
SW1-4	VD3	Byte-swap high and low data bytes	No byte-swap
SW1-5	VD7	I/O mapping address bit 4	See Table 2-2, "I/O Mapping Example"
SW1-6	VD8	I/O mapping address bit 5	
SW1-7	VD9	I/O mapping address bit 6	
SW1-8	-	Reserved	Reserved

**Note**

The polarity of the Configuration Dip Switches is Closed = "1" or "high", Open = "0" or "low".

**Note**

VD[15:0] have internal pull-down resistors and therefore external pull-up resistors are only required if the configuration option requires a "1" state on power-up.

**Factory set fixed options on this board are:**

- 16-bit display memory interface.
- All 128K bytes of video memory is available at memory segment \$D with software selecting one of two 64K memory banks (See "SRAM Support" on page 14).
- This board is pre-set to use indexed I/O with address \$03y0 (0000 0011 0yyy 000x), where x is don't care and yyy can be configured with dip-switch SW1-5 through SW1-7. The factory setting of yyy = 001, i.e., I/O address = \$0310 and \$0311.

Direct-mapping I/O is only available for Non-ISA Bus support. When using direct-mapped I/O, the I/O address is \$03yx (0000 0011 0yyy xxxx), where x is don't care and yyy can be configured with dip-switch SW1-5 through SW1-7. If yyy = 001, then the I/O address for Aux[00] = \$0310, I/O address for Aux[01] = \$0311, I/O address for AUX[02] = \$0312 and so on. (See Non-ISA Bus Support, on page 14.)

Table 2-2: I/O Mapping Example

	bit 6	bit 5	bit 4
I/O Mapping Address (Hex)	0	0	1

Table 2-3: Decoding Jumper Setting

	Description	1-2	2-3
JP1	Set to the same polarity as SW1-1 (VD0)	1	0
JP2	Set to the same polarity as SW1-5 (VD7)	1	0
JP3	Set to the same polarity as SW1-6 (VD8)	1	0
JP4	Set to the same polarity as SW1-7 (VD9)	1	0
JP5	XSCL2 clock for Passive Color 8-bit single 640x480 LCD Panel (Format 1) (see Functional Specification, X07-SP-001-xx)	NC	XSCL2

**Note**

These jumpers are necessary for the external ISA Bus decode logic.

**Hard-Wired Configuration Inputs**

For ISA bus support options, external 10K ohm pull-up resistors have been assembled, and are connected to signal lines VD11, VD12, VD14 and VD15 (R6, R5, R4 and R3 respectively).

For Non-ISA bus support (see page 14), the following signal lines may require the 10K ohm pull-up resistors installed:

VD4 (R18), VD5 (R19), VD6 (R20), VD10 (R21) and/or VD13 (R17)

See the SED1353F0A Hardware Functional Specification, X18A-A-001-xx, page 21 for configuration details.

## LCD Signal Connector Pinout

Table 2-4: LCD Signal Connector J1 Pinout

SED1353 Pin Name	LCD Connector Pin No.	Color STN LCD					Mono STN LCD	
		16-bit Single/Dual	8-bit Dual	8-bit Single (Format 1 <sup>a</sup> ) Aux[03] bit 3 =0, Aux[01] bit 2=1	8-bit Single (Format 2 <sup>a</sup> ) Aux[03] bit 3 =1, Aux[01] bit 2=1	4-bit	8-bit	4-bit
LD0	1	LD0	LD0	LD0	LD0		LD0	
LD1	3	LD1	LD1	LD1	LD1		LD1	
LD2	5	LD2	LD2	LD2	LD2		LD2	
LD3	7	LD3	LD3	LD3	LD3		LD3	
UD0	9	UD0	UD0	UD0	UD0	UD0	UD0	UD0
UD1	11	UD1	UD1	UD1	UD1	UD1	UD1	UD1
UD2	13	UD2	UD2	UD2	UD2	UD2	UD2	UD2
UD3	15	UD3	UD3	UD3	UD3	UD3	UD3	UD3
	17	LD4 <sup>b</sup>						
	19	LD5 <sup>b</sup>						
	21	LD6 <sup>b</sup>						
	23	LD7 <sup>b</sup>						
	25	UD4 <sup>b</sup>						
	27	UD5 <sup>b</sup>						
	29	UD6 <sup>b</sup>						
	31	UD7 <sup>b</sup>						
XSCL	33	XSCL	XSCL	XSCL	XSCL	XSCL	XSCL	XSCL
WF/XSCL2	35			XSCL2				
LP	37	LP	LP	LP	LP	LP	LP	LP
YD	39	YD	YD	YD	YD	YD	YD	YD
GRND	2-26 (even pins)	GRND	GRND	GRND	GRND	GRND	GRND	GRND
N/C	28							
VLCD	30	VLCD	VLCD	VLCD	VLCD	VLCD	VLCD	VLCD
VCC	32	+5 V	+5 V	+5 V	+5 V	+5 V	+5 V	+5 V
+12 V	34	+12 V	+12 V	+12 V	+12 V	+12 V	+12 V	+12 V
VDDH	36	VDDH	VDDH	VDDH	VDDH	VDDH	VDDH	VDDH
WF/XSCL2	38	WF	WF		WF	WF	WF	WF
LCDENB	40	/LCDPWR	/LCDPWR	/LCDPWR	/LCDPWR	/LCDPWR	/LCDPWR	/LCDPWR

<sup>a</sup> See Sections 7.4.3 and 7.4.5 of the SED1353F0A Hardware Functional Specification, X18A-A-001.01, for details.<sup>b</sup> From external logic; see Section 3.5 for details.

## CPU / BUS Interface Connector Pinouts

Table 2-5: CPU/BUS Connector HI Pinout

Connector Pin No.	CPU/BUS Pin Name	Comments
1	SD0	Connected to DB0 of the SED1353
2	SD1	Connected to DB1 of the SED1353
3	SD2	Connected to DB2 of the SED1353
4	SD3	Connected to DB3 of the SED1353
5	GND	Ground
6	GND	Ground
7	SD4	Connected to DB4 of the SED1353
8	SD5	Connected to DB5 of the SED1353
9	SD6	Connected to DB6 of the SED1353
10	SD7	Connected to DB7 of the SED1353
11	GND	Ground
12	GND	Ground
13	SD8	Connected to DB8 of the SED1353
14	SD9	Connected to DB9 of the SED1353
15	SD10	Connected to DB10 of the SED1353
16	SD11	Connected to DB11 of the SED1353
17	GND	Ground
18	GND	Ground
19	SD12	Connected to DB12 of the SED1353
20	SD13	Connected to DB13 of the SED1353
21	SD14	Connected to DB14 of the SED1353
22	SD15	Connected to DB15 of the SED1353
23	RESET	Connected to the RESET signal of the SED1353
24	GND	Ground
25	GND	Ground
26	GND	Ground
27	+12V	12 volt supply
28	+12V	12 volt supply
29	/SBHE	Connected to the BHE# signal of the SED1353
30	IOCHRDY	Connected to the READY signal of the SED1353
31	/IOSC	Connected to the IOCS# signal of the SED1353
32	/MEMCS	Connected to the MEMCS# signal of the SED1353

Table 2-6: CPU/BUS Connector H2 Pinout

Connector Pin No.	CPU/BUS Pin Name	Comments
1	SA0	Connected to AB0 of the SED1353
2	SA1	Connected to AB1 of the SED1353
3	SA2	Connected to AB2 of the SED1353
4	SA3	Connected to AB3 of the SED1353
5	SA4	Connected to AB4 of the SED1353
6	SA5	Connected to AB5 of the SED1353
7	SA6	Connected to AB6 of the SED1353
8	SA7	Connected to AB7 of the SED1353
9	GND	Ground
10	GND	Ground
11	SA8	Connected to AB8 of the SED1353
12	SA9	Connected to AB9 of the SED1353
13	SA10	Connected to AB10 of the SED1353
14	SA11	Connected to AB11 of the SED1353
15	SA12	Connected to AB12 of the SED1353
16	SA13	Connected to AB13 of the SED1353
17	GND	Ground
18	GND	Ground
19	SA14	Connected to AB14 of the SED1353
20	SA15	Connected to AB14 of the SED1353
21	SA16	Connected to U2 pin 20
22	SA17	Connected to AB17 of the SED1353
23	SA18	Connected to AB18 of the SED1353
24	SA19	Connected to AB19 of the SED1353
25	GND	Ground
26	GND	Ground
27	+5V	5 volt supply
28	+5V	5 volt supply
29	/IOW	Connected to the IOW# signal of the SED1353
30	/IOR	Connected to the IOR# signal of the SED1353
31	/SMEMW	Connected to the MEMW# signal of the SED1353
32	/SMEMR	Connected to the MEMR# signal of the SED1353



## 3 TECHNICAL DESCRIPTION

### 3.1 ISA Bus Support

This board directly supports the 8/16-bit ISA Bus with Indexed I/O via a standard AT edge connector. Only those configuration resistors needed for ISA Bus support have been assembled, refer to Hard-Wired Configuration Inputs, on page 9 for configuration details. External logic has been added to provide signals which the SED1353F0A does not directly support. See Application Note X18A-G-003-xx for details.

This board is pre-set to use indexed I/O with base address 000 0011 0yyy 000x, where x is don't care and yyy can be configured through dip-switch SW1-7 to SW1-5. The factory setting of yyy = 001, i.e., I/O address = \$0310 and \$0311. The display memory bank address is described in SRAM Support, on page 14.

Example:

```
I/O write $310 01 :set index = 1
I/O read $311      :read contents of AUX[1]
I/O write $310 05 :set index = 5
I/O write $311 07 :write 07 to AUX[5]
```

This board has been designed to operate as a stand-alone card or in conjunction with either a VGA or a monochrome display adapter card.

#### With VGA

When the VGA display adapter used is an ISA or VL bus with an 8-bit BIOS EPROM (normally just one ROM on the adapter card) the SDU1353B0C must be configured as follows:

SW1-1 open	: 8-bit operation, necessary to prevent MEMCS16# conflict when reading VGA BIOS
SW1-2 to 4 open	: for ISA bus support with indexed I/O
SW1-5 to 7	: set as desired
JP1 2-3 shorted	: to reflect SW1-1 polarity
JP2 to JP4	: to reflect SW1-5 to 7 polarity
JP5	: set as required for panel

When the ISA or VL bus VGA video adapter has a 16-bit BIOS EPROM (normally two ROMs on the adapter card), the 16-bit ISA bus interface (SW-1 closed) must be used on the SDU1353B0C.

When using the SDU1353B0C in conjunction with a PCI bus VGA display adapter either the 16-bit ISA bus interface or the 8-bit ISA bus interface may be used on the SDU1353B0C.

#### With Monochrome

When using the SDU1353B0C in conjunction with a monochrome display adapter either the 16-bit ISA bus interface or the 8-bit ISA bus interface may be used on the SDU1353B0C.

#### Stand-Alone

The SDU1353B0C can be used as a stand-alone video adapter. When used as a stand-alone video adapter the BIOS setup program for the computer must support and have "No Video" selected as the video adapter. The 1353BIOS.COM utility program can be used with the evaluation board to simulate a standard video BIOS, thus providing text and cursor functionality. See the 1353BIOS.COM Utility manual, X18A-B-003-xx for details.

### 3.2 Non-ISA Bus Support

This evaluation board was specifically designed to support the standard 8/16-bit ISA bus. However, as the SED1353F0A does support other bus interfaces, header strips have been provided containing all necessary I/O pins. (See Table 2-1, Configuration DIP Switch Settings, on page 8, Hard-Wired Configuration Inputs, on page 9, and CPU/Bus Interface Header Strips, on page 16, for details.)

When using the header strips to provide the bus interface observe the following:

1. All I/O signals on the ISA bus card edge must be isolated from the ISA Bus (do not plug the card into a computer). Voltage lines are provided on the header strips.
2. U2, a TIBPAL22V10 PAL, is currently used to provide the SED1353F0A IOCS# (pin 23) and MEMCS# (pin 22) input signals for ISA bus use. This functionality must now be provided externally as U2 must be removed.
3. Linear addressing of the entire 128K bytes of video RAM is available. Due to the memory banking method used for ISA bus support, U2 must be removed and H2, pin 21, must be physically connected to U2, pin20, in order to provide SA16 to U1.
4. If it becomes necessary / desirable to change the configuration information associated with VD[15:0], additional 10K Ohm pull-up resistors can be added to those affected VD lines as there are place holders available on the PCB.

### 3.3 SRAM Support

The SDU1353B0C board supports 16-bit wide, 128K byte SRAM. In order for the SDU1353B0C to operate in conjunction with a VGA card and not cause memory space conflicts, all 128K bytes of memory is available through two 64K byte banks. The first 64K bank is selected by *reading* from the base I/O mapping address + 2 (address \$312 if the I/O address is \$310) and the second 64K bank is selected by *writing* to I/O address + 2 (address \$312 if the I/O address is \$310). The display memory banks reside at the 64K byte memory segment \$D.

```
I/O read $312      :select memory bank 0
I/O write $312     :select memory bank 1
```

### 3.4 Monochrome LCD Support

The SED1353F0A directly supports 4/8-bit Dual and Single monochrome LCD panels. All the necessary signals are provided on the 40-pin ribbon cable header. The interface signals are alternated with grounds on the cable to reduce cross talk and noise related problems.

Refer to Table 2-4, LCD Signal Connector J1 Pinout, on page 10 for specific settings.

### 3.5 Color LCD Support

The SDU1353B0C directly supports 4/8/16-bit Dual and Single color LCD panels. All the necessary signals are provided on the 40-pin ribbon cable header. The interface signals are alternated with grounds on the cable to reduce cross talk and noise related problems.

To facilitate interfacing a 16-bit panel to the SED1353F0A, the following external circuit is implemented on-board:

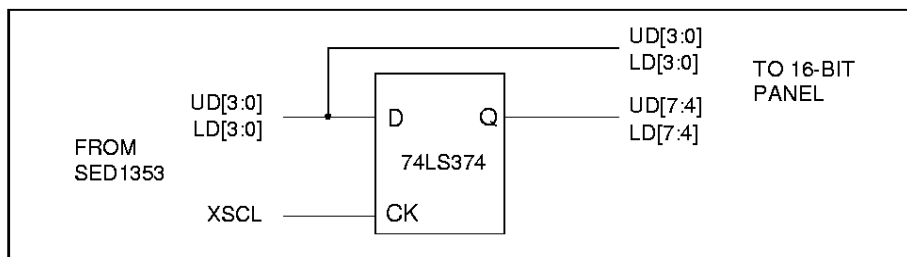

This circuit provides 16-bit color panel support by latching the 8 bits of output data from the SED1353F0A to provide 16 bits of data on the next clock. Refer to Table 2-4, LCD Signal Connector J1 Pinout, on page 10 for specific settings.

### 3.6 Power Save Modes

The SED1353F0A supports two software Power Save Modes. The utility program 1353PD.EXE is supplied to control these software modes. The software modes are controlled by directly writing the SED1353F0A associated internal registers.

### 3.7 Adjustable LCD Panel Negative Power Supply

The majority of Monochrome LCD panels require a negative power supply to provide between -18 V and -23 V ( $I_{out}=45mA$ ). For ease of implementation, such a power supply has been provided as an integral part of this design. The signal VLCD can be adjusted by R11 (100K potentiometer) to provide an output voltage from -14 V to -23 V and enabled/disabled by the control signal LCDENB.

#### Note

LCDENB is directly controlled by register AUX[01], bit 4, of the SED1353F0A. The VLCD power supply used on the SDU1353B0C requires a logic "1" to disable it. As the signal LCDENB is a logic "0" at power-up, it is inverted by external logic to disable VLCD and prevent damaging the panel connected to the SDU1353B0C.

Determine the panel's specific power requirements and set the potentiometer accordingly before connecting the panel.

### 3.8 Adjustable LCD Panel Positive Power Supply

The majority of LCD Passive Color panels and most single Monochrome 640x480 STN LCD panels require a positive power supply to provide between +23V and +40V ( $I_{out}=45mA$ ). For ease of implementation, such a power supply has been provided as an integral part of this design. The signal VDDH can be adjusted by R8 (100K potentiometer) to provide an output voltage from +23 V to +40 V and enabled/disabled by the control signal LCDENB.

#### Note

LCDENB is directly controlled by register AUX[01], bit 4, of the SED1353F0A. The VDDH power supply used on the SDU1353B0C requires a logic "1" to disable it. As the signal LCDENB is a logic "0" at power-up, it is inverted by external logic to disable VLCD and prevent damaging the panel connected to the SDU1353B0C.

Determine the panel's specific power requirements and set the potentiometer accordingly before connecting the panel.

### 3.9 Crystal Support

The input crystal frequency may be up to 25.0 Mhz depending on the specific panel size and frame rate desired.

Refer to *Section 9.3 of the SED1353F0A Functional Specification*, Drawing Office No. X18A-A-001-xx for further details.

### 3.10 Oscillator Support

The input oscillator frequency used may be up to 25.0 MHz, depending on the specific panel size and frame rate desired.

Refer to *Section 9.3 of the SED1353F0A Functional Specification*, Drawing Office No. X18A-A-001-xx for further details.

**Note**

When the oscillator package is used capacitors C7, C8 and resistor R16 must be removed.

### 3.11 CPU/Bus Interface Header Strips

All of the CPU/Bus interface pins of SED1353F0A, with the exception of SA16, are connected to the header strips H1 and H2 for easy interface to a CPU/Bus other than the ISA bus.

Refer to Table 2-5, CPU/BUS Connector H1 Pinout, on page 11 and Table 2-6, CPU/BUS Connector H2 Pinout, on page 12 for specific settings.

**Note**

These headers only provide the CPU/Bus interface signals from SED1353F0A, when MC68000 interface is selected (SW1-3 closed), external decoding logic **MUST** be used to access the SED1353F0A.

### 3.12 Schematic Notes

This evaluation board may have been modified and therefore the following schematics may not reflect the actual implementation. Please request updated information before starting any hardware design.

## Appendix A Parts List

Item #	Qty/board	Designation	Part Value	Description
1	13	C11-C23	0.01uF	0.01uF, 1206 pckg
2	2	C9 -C10	10uF	10uF / 25V Tantalum D-SIZE
3	2	C7-C8	7pF	7pF, 1206 pckg
4	3	C2-C4	10uF / 63V	Electrolytic / Radial (LXF63VB10RM5X11LL)
5	3	C1, C5, C6	56uF/35V	LXF35VB56RM6X11LL
6	2	H1, H2	CON32A	32-pin Dual Row Header
7	5	JP1-JP5	Header 3	3-pin single Row Header
8	1	J1	CON40A	Shrouded Header 40 pin Dual-row center-key PTH
9	1	L1	1uH	Dale Inductor IM-4-1.0uH PTH
10	2	L2-L3	Ferrite Bead	Fair-rite 2743001111
11	1	Q1	2N3906	PNP Signal Transistor TO-92 PTH
12	1	Q2	2N3903	NPN Signal Transistor TO-92 PTH
13	3	R2, R13, R14	1K	1K Ohm/1206/5%
14	2	R12, R15	100K	100K Ohm/1206/5%
15	4	R3-R6	10K	10K Ohm/1206/5%
16	1	R7	470K	470K Ohm/1206/5%
17	1	R8	200K	200K Ohm Trim POT Spectrol 63S204T607
18	1	R9	10K	10K 10-pin SIP, Part No. 4610X-101-103
19	1	R10	14K	14K Ohm/1206/5%
20	1	R11	100K	100K Ohm Trim POT Spectrol 63S104T607
21	1	R16	2M	2M Ohm/1206/5%
22	1	R1	0 Ohm	0 Ohm / 1206 / 1%
23	5	R17-R21	10K	10K Ohm/1206/5%
24	1	S1	SW-DIP-8	DIP Switch 8-position
25	1	U1	SED1353FOA	QFP5-100-S2
26	1	U2	TIBPAL22V10	Texas Ins. PAL, Socketed
27	2	U3, U4	74LS688	DW020 SMT Package
28	1	U5	74LS09	D014 SMT Package
29	2	U6, U7		SRM20100LTM-70 128K x 8 SRAM
30	1	U8	RD-0412	XENTEK - Positive Power Supply
31	1	U9	EPN001	XENTEK - Negative Power Supply
32	1	U10	OSC-14	14-pin Socket for 25.0MHz, 12.0Mhz, and 6.0Mhz 14-pin Oscillators
33	1	U11	74LS374	DW020 SMT Package
34	1	Y1	25.175Mhz	Crystal

# Appendix B SDU1353B0C Rev. 1.0 Schematic Diagrams

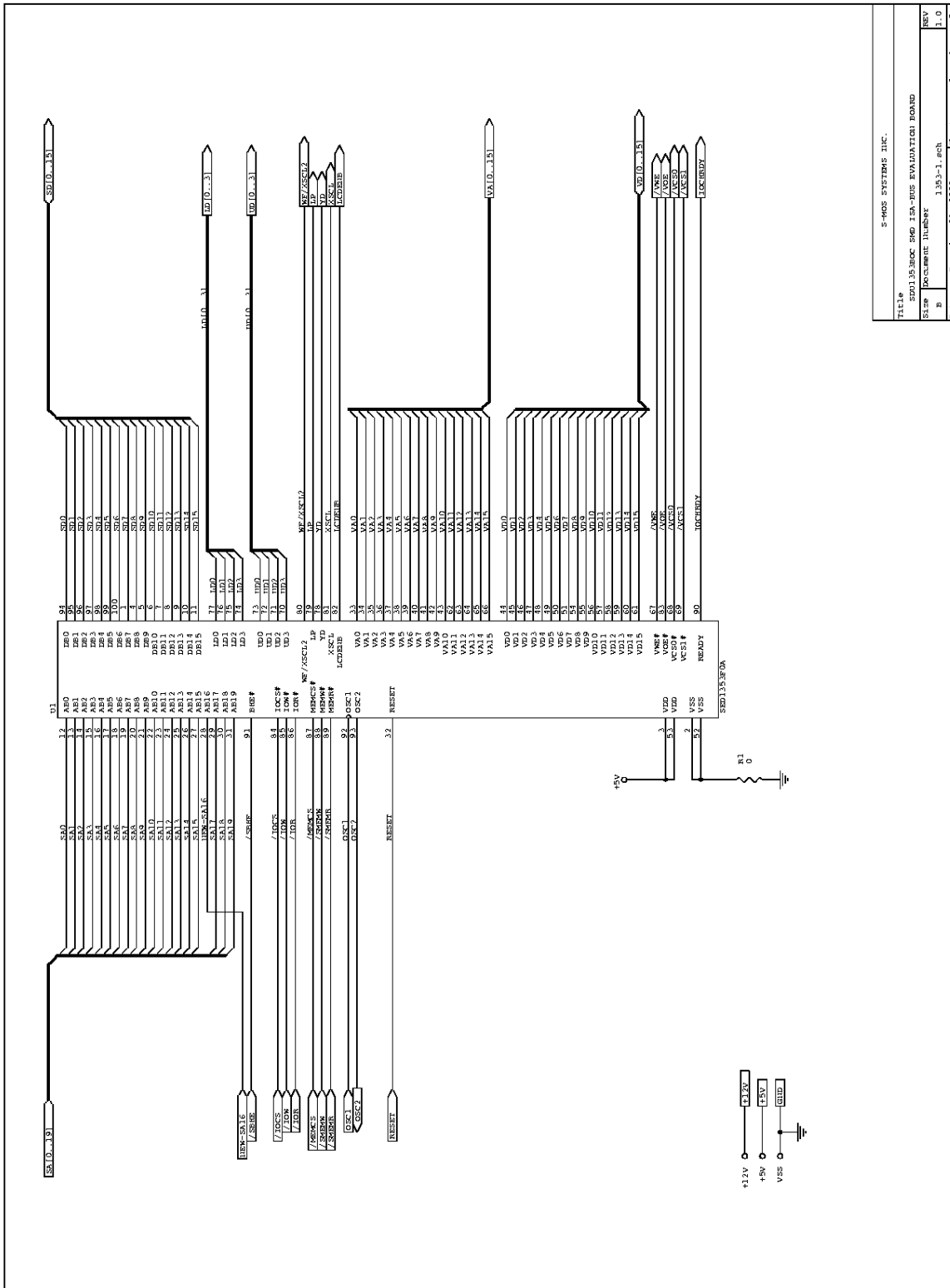

Figure 1: SDU1353B0C Rev. 1.0 Schematic Diagram (1 of 7)

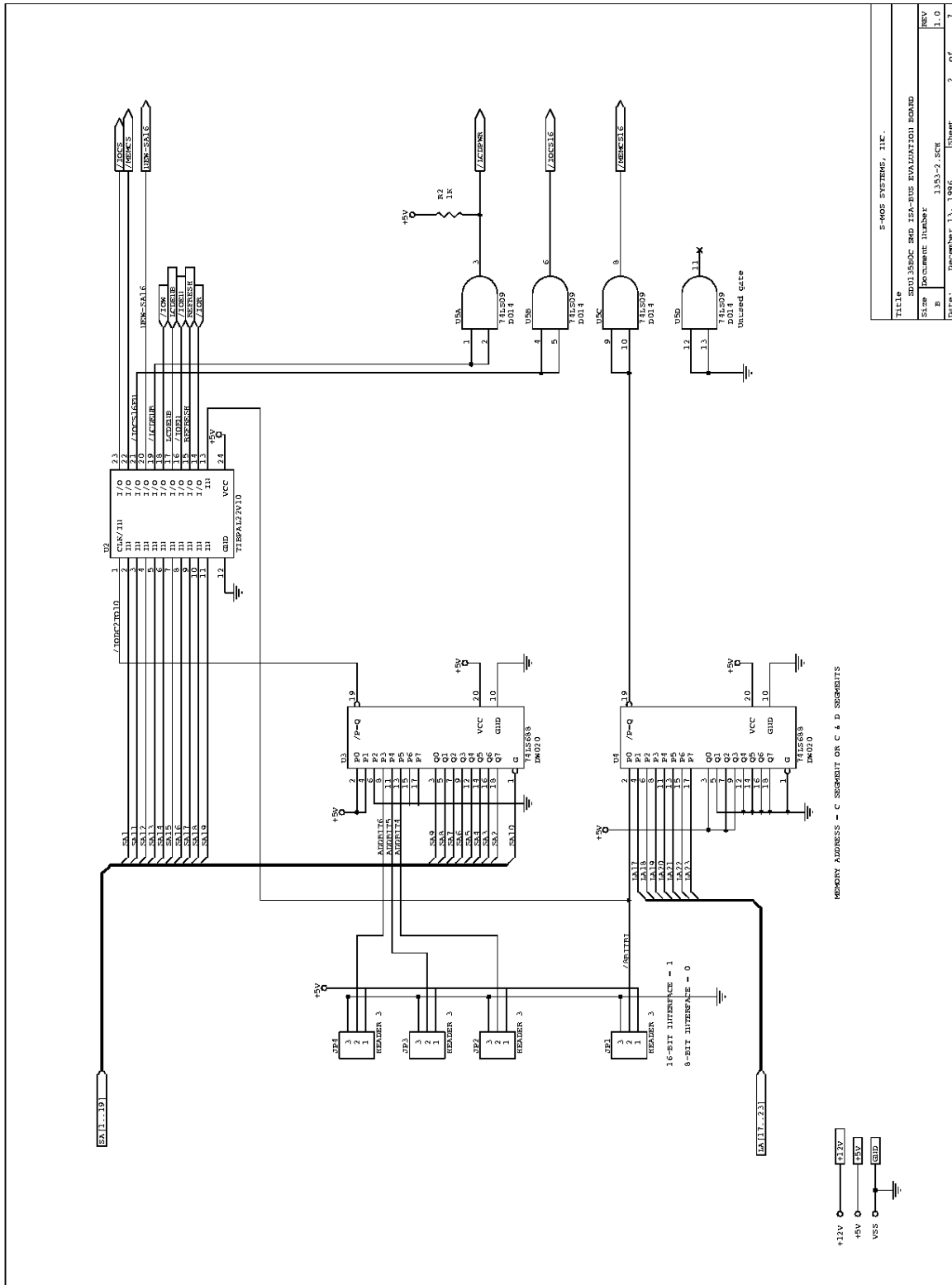
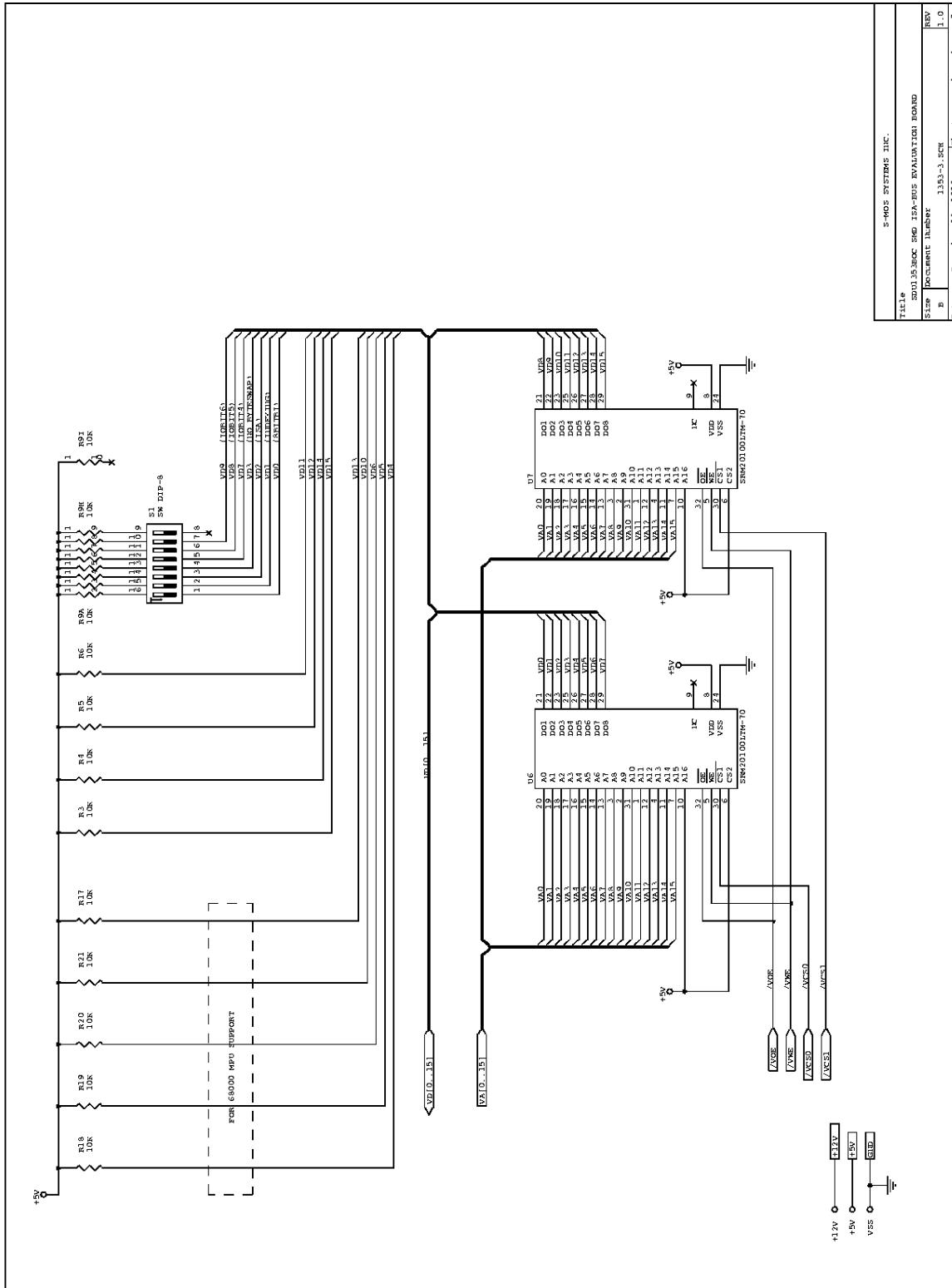

Figure 2: SDU1353B0C Rev. 1.0 Schematic Diagram (2 of 7)



S-MOS SYSTEMS INC.			
TITLE	SDU1353B0C 5V8 15A-BUS EVALUATION BOARD	REV	7
SHEET	DOCUMENT NUMBER 1353-3.2CR	REV	1.0
DATE	DECEMBER 12, 1995	SHEET	3 OF 7

Figure 3: SDU1353B0C Rev. 1.0 Schematic Diagram (3 of 7)



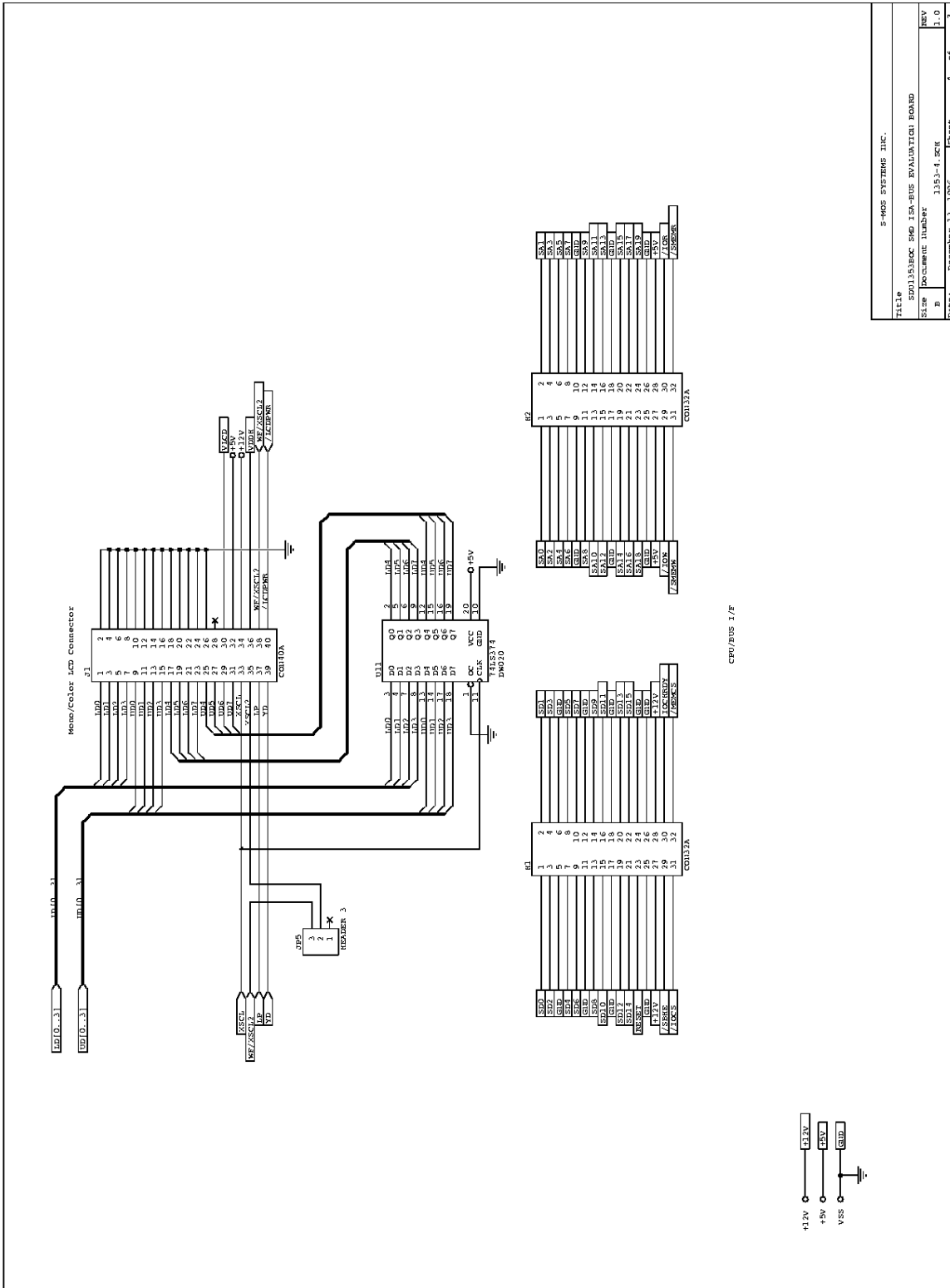

Figure 4: SDU1353B0C Rev. 1.0 Schematic Diagram (4 of 7)

S-MOS SYSTEMS INC.			
TITLE	SDU1353B0C SMP ISA-BUS EVALUATION BOARD	REV	1.0
SIZE	Document Number		
B	1353-4.2C1	SHEET	4 OF 7
DATE:	December 13, 1995		

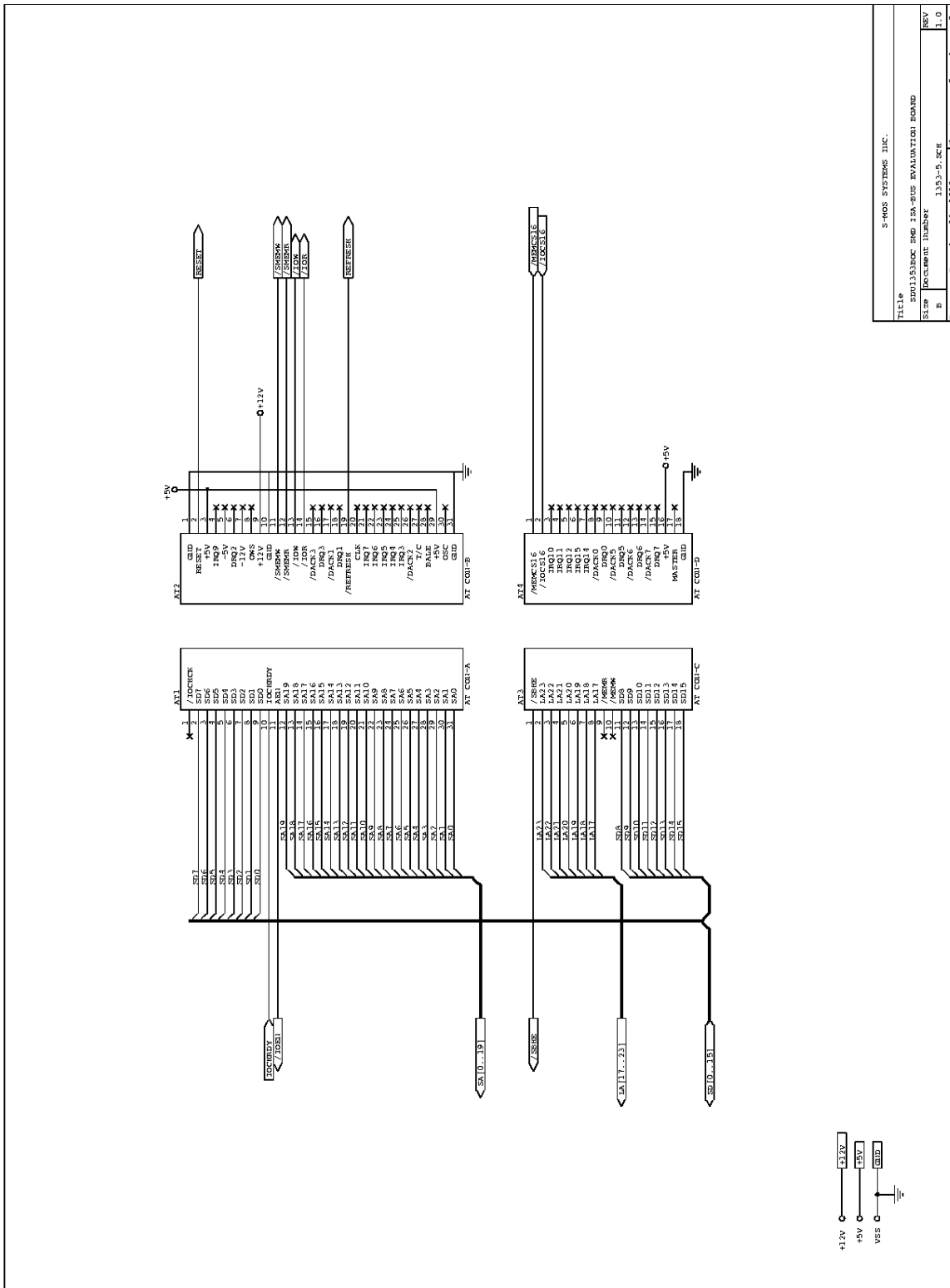
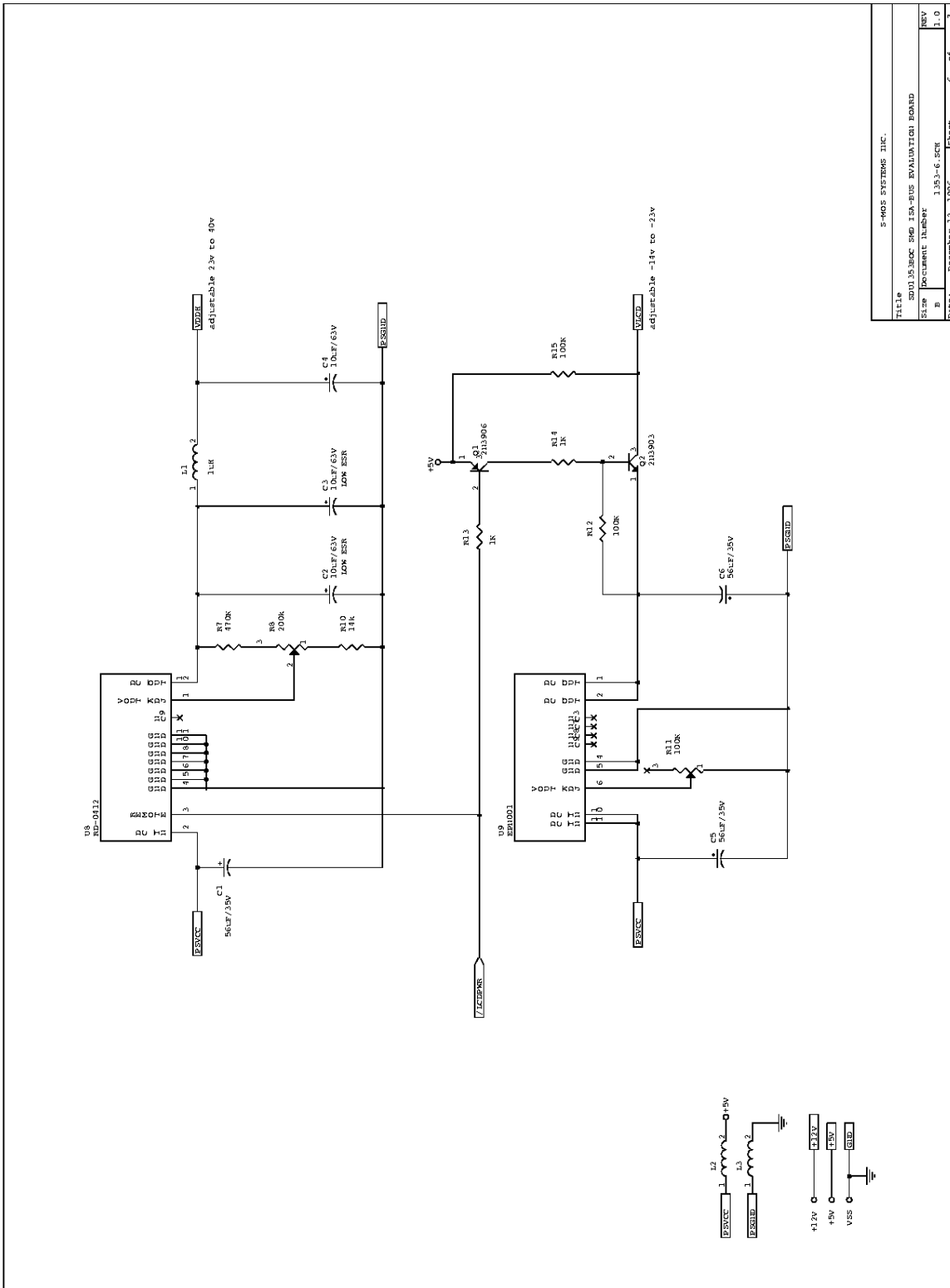

Figure 5: SDU1353B0C Rev. 1.0 Schematic Diagram (5 of 7)



S-MOS SYSTEMS INC.	
Title	SDU1353B0C SMD ISA-BUS EVALUATION BOARD
Size	Document Number
B	1353-6.SCH
Date:	December 12, 1995
Sheet	6 of 7
REV	1.0

Figure 6: SDU1353B0C Rev. 1.0 Schematic Diagram (6 of 7)

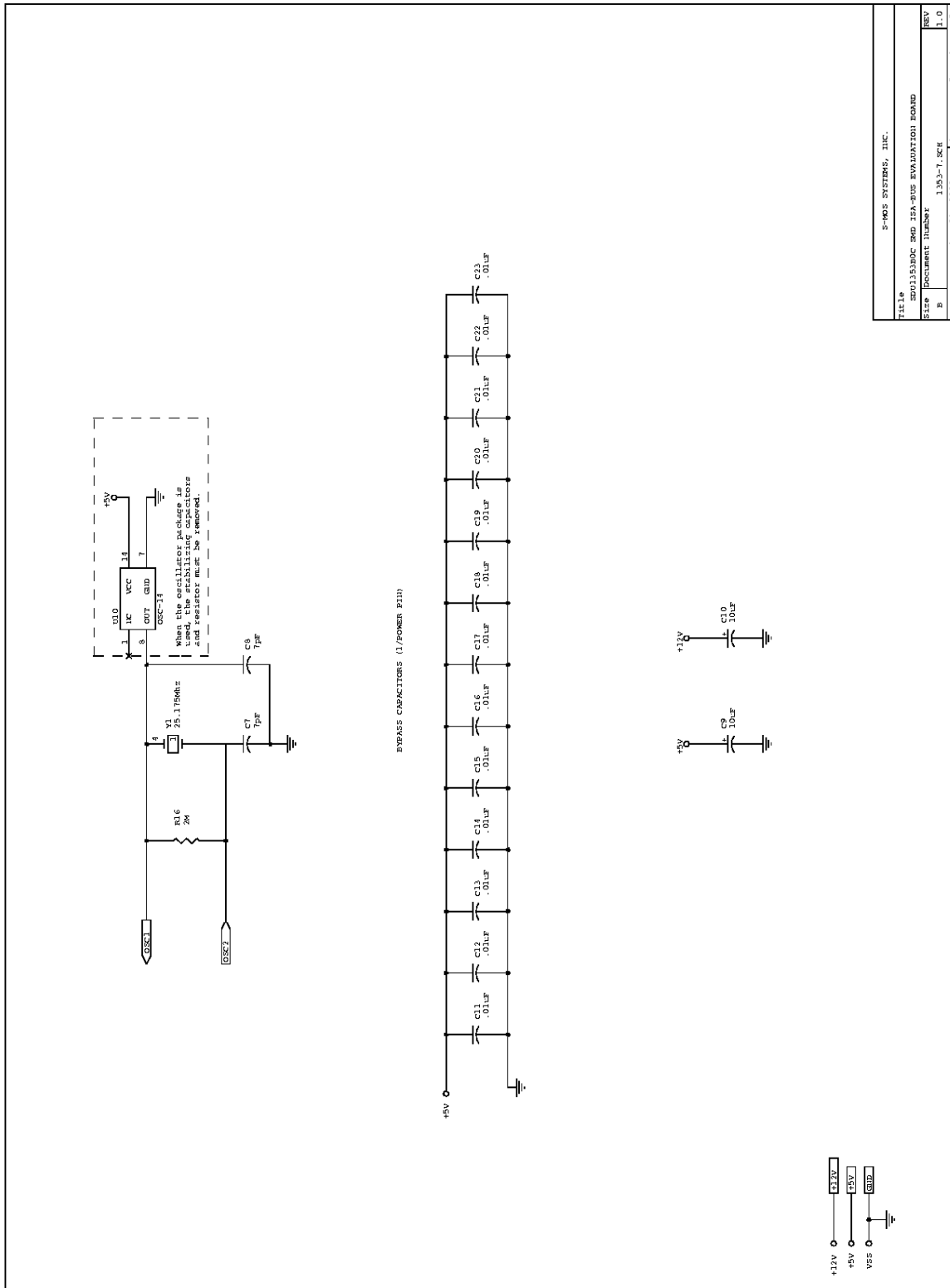

Figure 7: SDU1353B0C Rev. 1.0 Schematic Diagram (7 of 7)

## **SED1353 Dot Matrix Graphics LCD Controller**

# **Power Consumption**

**Drawing Office No. X18A-G-006-01**

Copyright © 1997 S-MOS Systems Inc. All rights reserved.

This document, and any text derived, extracted or transmitted from it, is the sole property of S-MOS Systems Inc. and may not be used, copied, transmitted or otherwise made available to any other person, unless specifically allowed under license agreement with S-MOS Systems Inc. If furnished under a license, this document may be used and copied only in accordance with the terms of such license, and with the inclusion of this copyright notice. No title or ownership of the technology herein is transferred.

The information in this document is subject to change without notice and should not be construed as a commitment by S-MOS Systems Inc. This document does not necessarily describe any current planned or future product by S-MOS Systems Inc., nor does it represent any commitment to implement any such product.

**THIS PAGE LEFT BLANK**

# 1 SED1353 POWER CONSUMPTION

## 1.1 Conditions

Table 1-1: SED1353 Total Power Consumption - 3.0V Operation

Test Condition		Gray Shades / Colors	Total Power Consumption		
			Active	Power Save Mode	
				1	2
1	Input Clock = 6 MHz LCD Panel Connected = 320x240 Monochrome V <sub>DD</sub> = 3.0V	Black-and-White	5.4 mW	1.2 mW	less than 300 uW
		4 Grays	6.4 mW	1.2 mW	less than 300 uW
		16 Grays	7.6 mW	1.2 mW	less than 300 uW
2	Input Clock = 6 MHz LCD Panel Connected = 320x240 Color V <sub>DD</sub> = 3. V	4 Colors	8.8 mW	1.2 mW	less than 300 uW
		16 Colors	10.3 mW	1.2 mW	less than 300 uW
		256 Colors	12.7 mW	1.2 mW	less than 300 uW
3	Input Clock = 25 MHz LCD Panel Connected = 640x480 Monochrome V <sub>DD</sub> = 3.0V	Black-and-White	19.7 mW	2.7 mW	less than 300 uW
		4 Grays	24.3 mW	2.7 mW	less than 300 uW
4	Input Clock = 25 MHz LCD Panel Connected = 640x480 Color V <sub>DD</sub> = 3.0V	4 Colors	33.1 mW	2.7 mW	less than 300 uW

Table 1-2: SED1353 Total Power Consumption - 5.0V Operation

Test Condition		Gray Shades / Colors	Total Power Consumption		
			Active	Power Save Mode	
				1	2
1	Input Clock = 6 MHz LCD Panel Connected = 320x240 Monochrome V <sub>DD</sub> = 5.0V	Black-and-White	26.0 mW	10.5 mW	1.2 mW
		4 Grays	29.7 mW	10.5 mW	1.2 mW
		16 Grays	35.7 mW	10.5 mW	1.2 mW
2	Input Clock = 6 MHz LCD Panel Connected = 320x240 Color V <sub>DD</sub> = 5.0V	4 Colors	37.8 mW	10.5 mW	1.2 mW
		16 Colors	44.5 mW	10.5 mW	1.2 mW
		256 Colors	52.8 mW	10.5 mW	1.2 mW
3	Input Clock = 25 MHz LCD Panel Connected = 640x480 Monochrome V <sub>DD</sub> = 5.0V	Black-and-White	76.0 mW	16.7 mW	1.0 mW
		4 Grays	92.0 mW	16.7 mW	1.0 mW
4	Input Clock = 25 MHz LCD Panel Connected = 640x480 Color V <sub>DD</sub> = 5.0V	4 Colors	120.8 mW	16.7 mW	1.0 mW

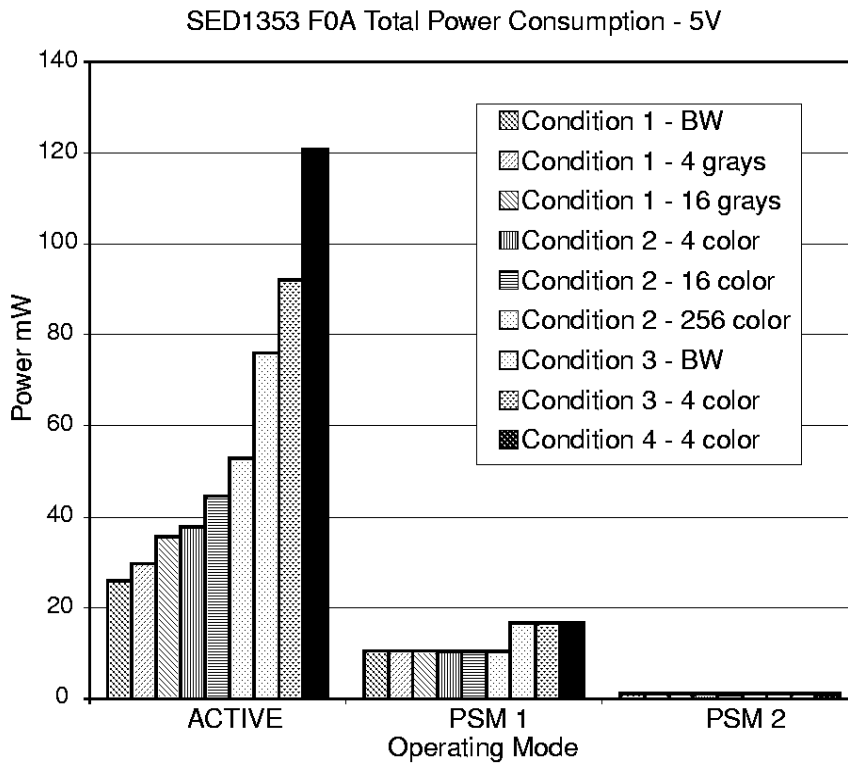
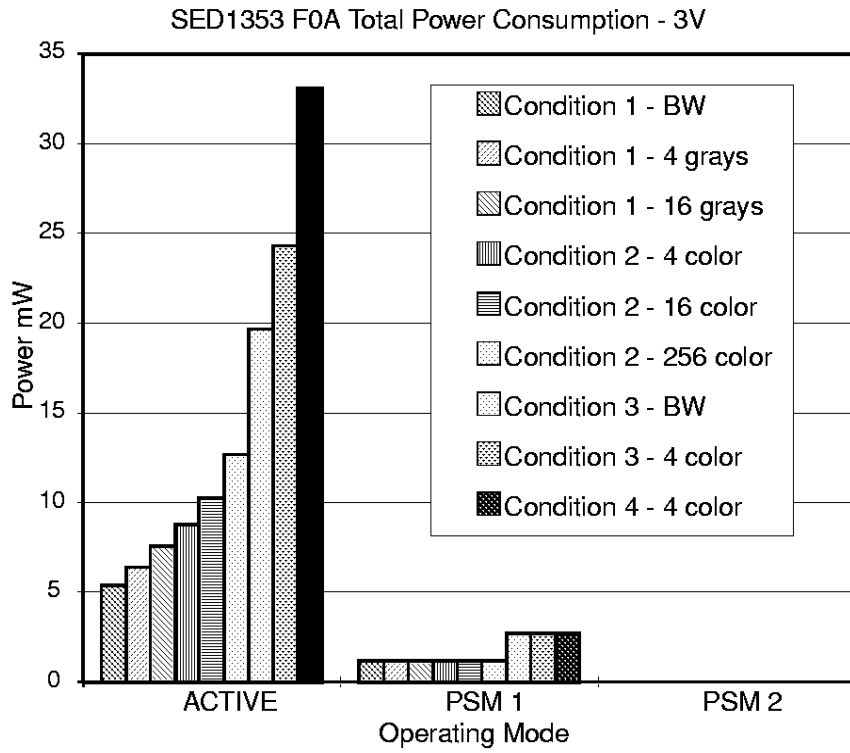



## **SED1353 Dot Matrix Graphics LCD Controller**

# **ISA Bus Interface Considerations**

**Drawing Office No. X18A-G-003-02**

Copyright © 1995, 1997 S-MOS Systems Inc. All rights reserved.

This document, and any text derived, extracted or transmitted from it, is the sole property of S-MOS Systems Inc. and may not be used, copied, transmitted or otherwise made available to any other person, unless specifically allowed under license agreement with S-MOS Systems Inc. If furnished under a license, this document may be used and copied only in accordance with the terms of such license, and with the inclusion of this copyright notice. No title or ownership of the technology herein is transferred.

The information in this document is subject to change without notice and should not be construed as a commitment by S-MOS Systems Inc. This document does not necessarily describe any current planned or future product by S-MOS Systems Inc., nor does it represent any commitment to implement any such product.

**THIS PAGE LEFT BLANK**

---

## Table of Contents

<b>1</b>	<b>INTRODUCTION</b>	<b>5</b>
1.1	Reference Material	5
<b>2</b>	<b>16-BIT ISA BUS INTERFACE</b>	<b>6</b>
2.1	PAL Equations	7
2.2	Additional Discrete Logic Description	7
2.3	SED1353F0A Default Setup	7
2.3.1	Configuration Options	7
2.3.2	Register Setting	8
<b>3</b>	<b>8-BIT ISA BUS INTERFACE</b>	<b>9</b>
3.1	SED1353F0A Default Setup	10
3.1.1	Configuration Options	10
3.1.2	Register Setting	10

## List of Figures

Figure 1:	16-Bit ISA Bus Implementation	4
Figure 2:	8-Bit ISA Bus Implementation	7

**THIS PAGE LEFT BLANK**

## 1 INTRODUCTION

The SED1353F0A is a general purpose LCD controller capable of interfacing to a variety of microprocessors. In some cases this interface is accomplished through the use of minimal external circuitry. This application note describes the interface between the SED1353F0A and the ISA Bus both 8 and 16-bit implementations.

### 1.1 Reference Material

Refer to the SED1353F0A Hardware Functional Specification (X18A-A-001-xx) for complete AC timing details.

This document makes no attempts to describe the operation of the ISA Bus, please refer to the appropriate ISA Bus documentation for complete information.

## 2 16-BIT ISA BUS INTERFACE

For the purpose of the example shown below, the following conditions apply:

1. Indexed I/O with addresses 0310h and 0311h (see Configuration Options)
2. 128Kbytes of display memory occupying \$C and \$D segments (see Configuration Options)

### Note

This memory configuration will conflict with a VGA card installed on the same bus, therefore either a serial terminal or monochrome display adapter is recommended as the primary console.

This section provides the necessary logic equations and settings to complete the interface between the SED1353F0A and the 16-bit ISA Bus.

### Note

A PAL was used instead of discrete logic to reduce external component count.

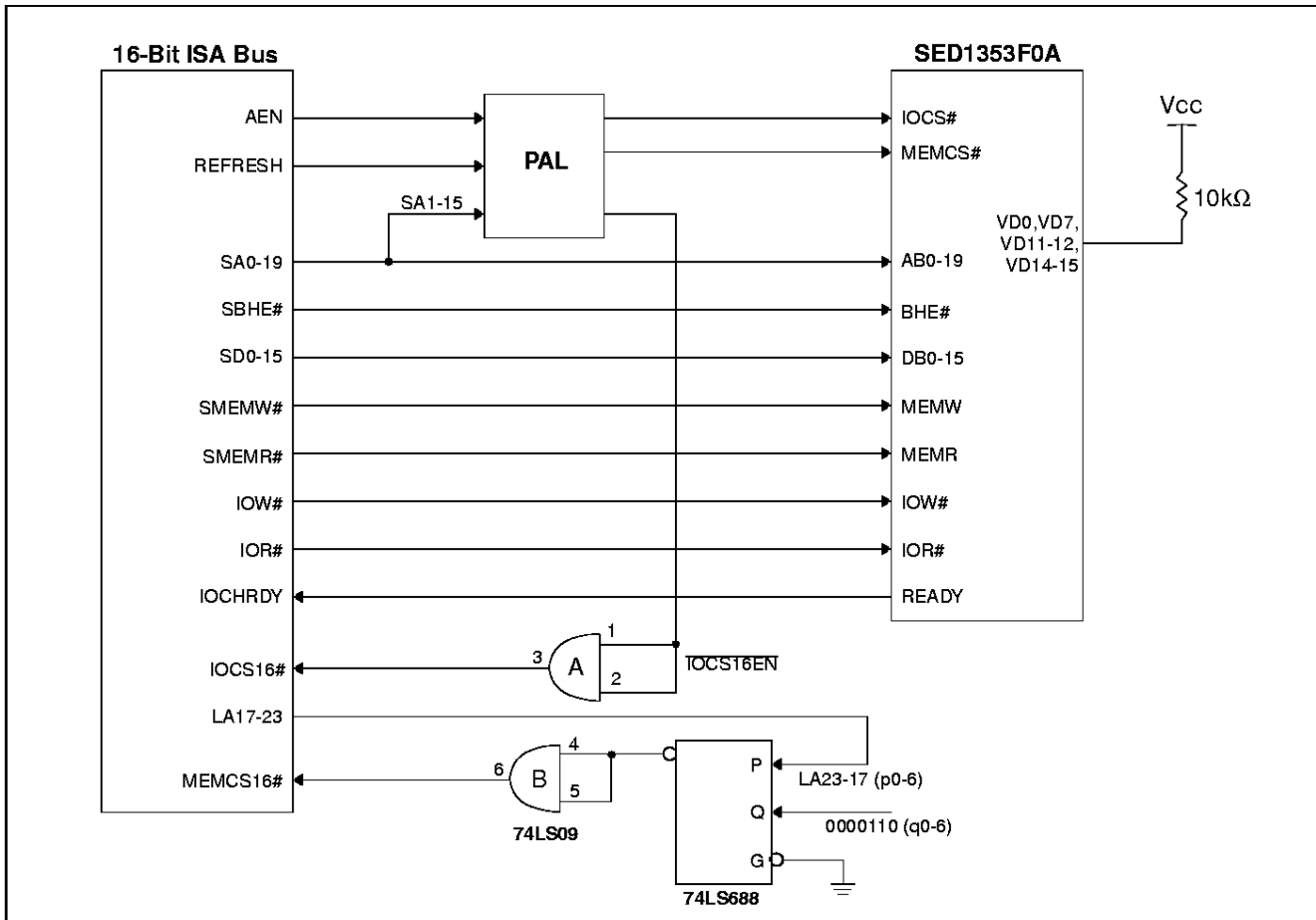

Figure 1: 16-Bit ISA Bus Implementation

## 2.1 PAL Equations

The PAL is programmed with the following equations:

### Note

A '!' placed before a signal name indicates a logic '0' state.  
A '&' indicates a logic 'AND' function.

1. As stated above, the default I/O address is from 0310h to 0311h. The SED1353F0A provides internal decoding of address bits A0 to A9, therefore minimal external circuitry is necessary to provide signals IOCS# and IOCS16#

IOCS# is required by the SED1353 to indicate a valid I/O cycle. In an ISA bus environment, valid I/O decoding must include addresses A15-A0. As A0-A9 are decoded internally, the equation must only guarantee that addresses A10-15 must all be '0' and AEN must also be '0'.

$$\text{IOCS\#} = \text{!(AEN \& A15 \& A14 \& A13 \& A12 \& A11 \& A10)}$$

2. As the SED1353 is capable of 16-bit I/O access, the IOCS16# bus signal must be driven externally to indicate such a cycle. As stated in the ISA specification, the IOCS16# is a straight address decode without qualification.

$$\text{IOCS16EN\#} = \text{!(IOCS\# \& A9 \& A8 \& A7 \& A6 \& A5 \& A4 \& A3 \& A2 \& A1)}$$

3. With 128Kbytes of display memory and A17 to A19 decoded internally to SED1353F0A;  
MEMCS# = !REFRESH

### Note

The MSBs of the address (A23:A20) need not be externally decoded if using SMEMW# and SMEMR# as they will only assert on addresses < 1Mb.

## 2.2 Additional Discrete Logic Description

1. As shown in Figure 1, the 74LS688 is configured as a memory decoder with valid addresses between 0C0000h and 0DFFFFh. This provides the MEMCS16# signal allowing for 16-bit memory cycles. As stated in the ISA specification, the MEMCS16# is a straight address decode without qualification.
2. The 74LS09 is used simply to provide the Open-Collector outputs necessary for the IOCS16# and MEMCS16# signals.

## 2.3 SED1353F0A Default Setup

### 2.3.1 Configuration Options

The SED1353 latches the state of the SRAM data bus during RESET to determine the power-on configuration. The chip has internal pull-down resistors and therefore external pull-ups are only necessary when requiring a '1' state, see below.

1. VD15 - VD13 = 110                      memory decoding for locations \$C and \$D segments
2. VD12 - VD4 = 110001000              I/O decoding for locations 0310h and 0311h (1100010000b - 1100010001b)
3. VD3 = 0                                  No byte swap of high and low bytes
4. VD2 = 0                                  ISA Bus interface, i.e. non- MC68K interface
5. VD1 = 0                                  Indexed I/O
6. VD0 = 1                                  16-bit bus interface

Where 1 = pull-up with a 10K resistor; 0 = no pull-up resistor

### 2.3.2 Register Setting

All register settings are completely programmable with the following exceptions:

- Memory Interface, AUX[1] bit 1 = 0 for 16-bit memory interface.

**Note**

This bit is forced = 0 when 16-bit CPU Interface is selected through VD0 on power-up.

- RAMS, AUX[1] bit 0, this bit is ignored in 16-bit memory configurations.

All other registers are dependent on display type, resolution, color and mode of operation, see Functional Specification for details.



### 3 8-BIT ISA BUS INTERFACE

For the purpose of the example shown below, the following conditions apply:

1. Indexed I/O with partial decoding, i.e. address lines A10 to A15 are not decoded for I/O cycles

**Note**

Partial decoding is quite safe on most ISA Bus systems as I/O addresses above 03FFh are rarely used.

2. I/O addresses are 0300h and 0301h (xxxxxx1100000000b and xxxxxx1100000001b)
3. 64Kbytes of display memory occupying \$A segment

**Note**

The 74LS00 is simply used to detect the \$B segment and invalidate the MEMCS# input.

**Note**

This memory configuration may conflict with a VGA card installed on the same bus, therefore either a serial terminal or monochrome display adapter is recommended as the primary console.

This section provides the necessary settings to complete the interface between the SED1353F0A and the 8-bit ISA Bus. Since I/O addresses are partially decoded, there is no need to use a PAL for decoding.

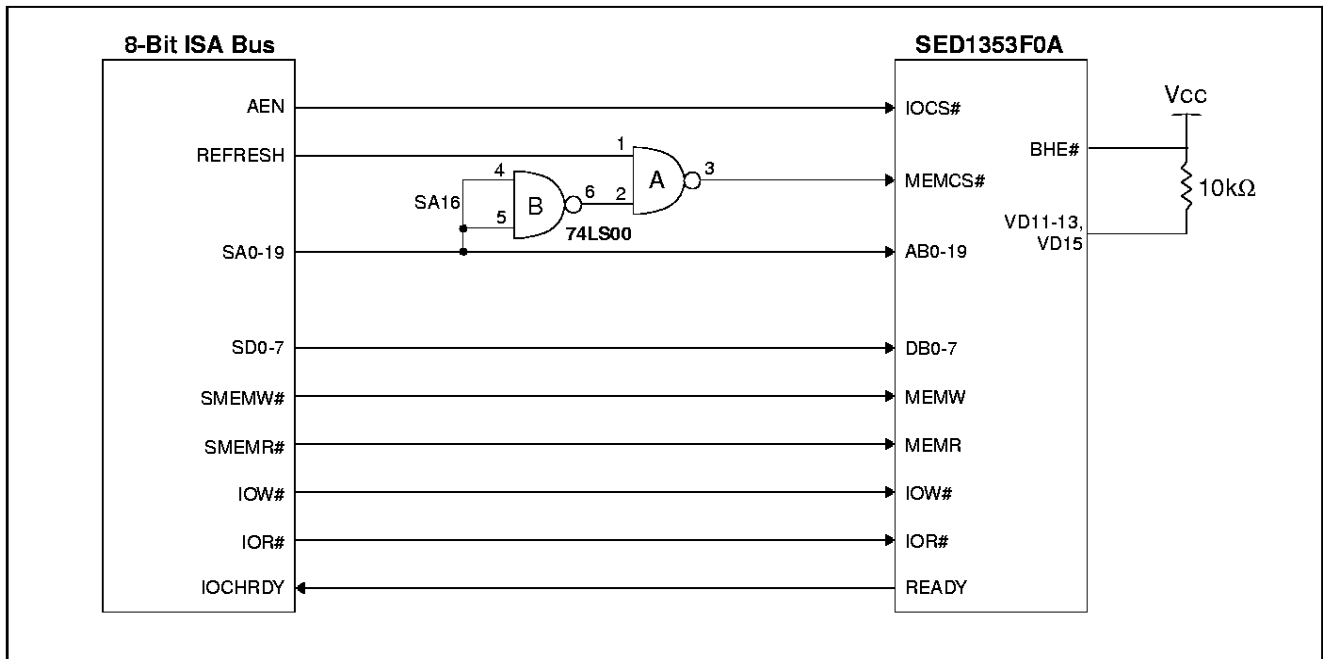

Figure 2: 8-Bit ISA Bus Implementation

## 3.1 SED1353F0A Default Setup

### 3.1.1 Configuration Options

The SED1353 latches the state of the SRAM data bus during RESET to determine the power-on configuration. The chip has internal pull-down resistors and therefore external pull-ups are only necessary when requiring a '1' state, see below.

1. VD15 - VD13 = 101                      memory decoding for locations \$A segment
2. VD12 - VD4 = 110000000              I/O decoding for locations 1100000000b - 1100000001b
3. VD3 = 0                                  No byte swap of high and low bytes
4. VD2 = 0                                  ISA Bus interface, i.e. non- MC68K interface
5. VD1 = 0                                  Indexed I/O
6. VD0 = 0                                  8-bit bus interface

Where 1 = pull-up with a 10K resistor; 0 = no pull-up resistor

### 3.1.2 Register Setting

All register settings are completely programmable and are dependent on display type, resolution, color and mode of operation, see Functional Specification for details.



## **SED1353 Dot Matrix Graphics LCD Controller**

# **MC68340 Interface Considerations**

**Drawing Office No. X18A-G-004-01**

Copyright © 1996, 1997 S-MOS Systems Inc. All rights reserved.

This document, and any text derived, extracted or transmitted from it, is the sole property of S-MOS Systems Inc. and may not be used, copied, transmitted or otherwise made available to any other person, unless specifically allowed under license agreement with S-MOS Systems Inc. If furnished under a license, this document may be used and copied only in accordance with the terms of such license, and with the inclusion of this copyright notice. No title or ownership of the technology herein is transferred.

The information in this document is subject to change without notice and should not be construed as a commitment by S-MOS Systems Inc. This document does not necessarily describe any current planned or future product by S-MOS Systems Inc., nor does it represent any commitment to implement any such product.

**THIS PAGE LEFT BLANK**

---

## Table of Contents

<b>1</b>	<b>INTRODUCTION</b>	<b>5</b>
1.1	Reference Material	5
<b>2</b>	<b>MC68340 MPU INTERFACE</b>	<b>6</b>
2.1	MC68340 Setup	6
2.2	PAL Equations	7
2.3	SED1353 Default Setup	7

## List of Figures

Figure 1:	MC68340 MPU Interface Block Diagram	6
-----------	-------------------------------------	---

**THIS PAGE LEFT BLANK**

## 1 INTRODUCTION

The SED1353 is a general purpose LCD controller capable of interfacing to a variety of microprocessors. This interface is accomplished through the use of minimal external circuitry. This application note describes the interface between the SED1353 and the 16-bit MC68340 microcontroller.

### 1.1 Reference Material

Refer to the SED1353 Hardware Functional Specification (X18A-A-001-xx) for complete AC timing details.

This document makes no attempts to describe the operation of the MC68340 microcontroller, please refer to the appropriate MC68340 documentation for this information.

## 2 MC68340 MPU INTERFACE

The following sections provide the necessary settings and equations to complete the interface between the SED1353 and the MC68340 microcontroller.

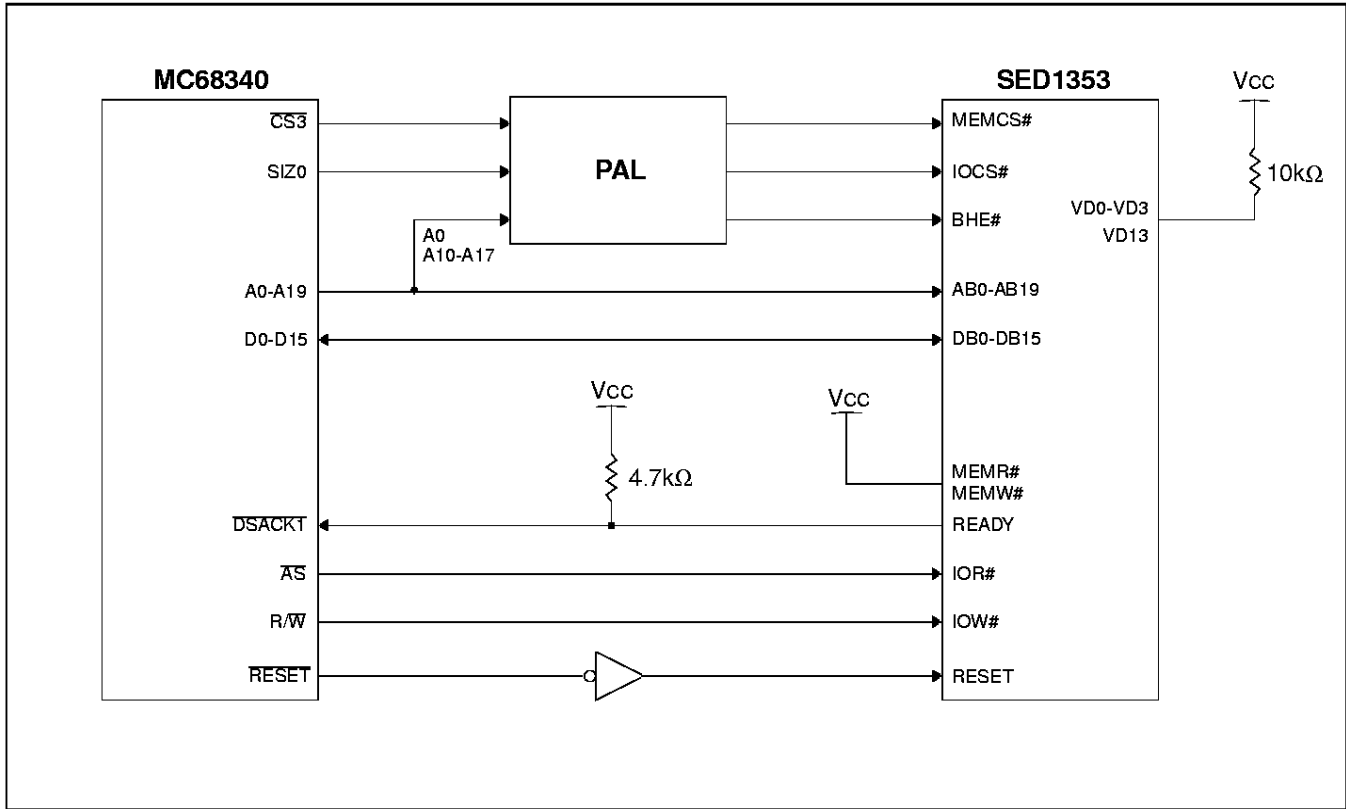

Figure 1: MC68340 MPU Interface Block Diagram

### 2.1 MC68340 Setup

For the purpose of this example, the following conditions apply:

The internal chip select signal  $\overline{CS3}$  of the MC68340, along with external  $\overline{DSACKT}$  response, is employed to access the SED1353. Direct mapping of the I/O with starting address at 00000000h, and 128Kbytes of display memory with starting address 00020000h are also used.

1.  $\overline{CS3}$  with 256kbyte block size - starting address at 00000000h and ending address at 0003FFFFh
2. External  $\overline{DSACKT}$  response - 16-bit port
3. Don't care Function Codes and with CPU space access
4. Both read and write accesses are allowed

Settings for the Address Mask register and Base Address register for the above conditions are:

058h - 05Bh = 0003FFFFh Address Mask register

05Ch - 05Fh = 000000F5h Base Address register



## 2.2 PAL Equations

The PAL is programmed with the following equations:

1. With direct-mapping I/O occupying locations from 00000000h to 0000000Fh and A4 to A9 decoded internally to SED1353;  
 $IOCS\# = \overline{!(CS\overline{3} \& !A17 \& !A16 \& !A15 \& !A14 \& !A13 \& !A12 \& !A11 \& !A10)}$
2. With memory locations from 00020000h to 003FFFFh and A17 to A19 decoded internally to SED1353;  
 $MEMCS\# = \overline{CS\overline{3}}$
3. BHE# becomes valid for two conditions:
  1. 16-bit or 32-bit cycle, i.e., SIZ0=0
  2. 8-bit cycle with odd byte access, i.e., SIZ0=1 and A0=1; $BHE\# = SIZ0 \& !A0$

## 2.3 SED1353 Default Setup

### Configuration Options

1. VD15 - VD13 = 001                      memory decoding for locations 20000h - 3FFFFh
2. VD12 - VD4 = 000000xxx              I/O decoding for locations 000000000b - 0000001111b
3. VD3 = 1                                    byte swap of high and low bytes
4. VD2 = 1                                    MC68K interface
5. VD1 = 1                                    direct-mapping I/O
6. VD0 = 1                                    16-bit bus interface

Where x = don't care; 1 = pull-up with a 10K resistor; 0 = no pull-up resistor

### Note

The states of these data pins are internally latched during RESET.

### Register Setting

AUX[1] bit 1 = 0 for 16-bit memory interface (must be 16-bit with a 16-bit bus).

**THIS PAGE LEFT BLANK**



## **SED1353 Dot Matrix Graphics LCD Controller**

# **LCD Panel Options / Memory Requirements**

**Drawing Office No. X18A-G-005-02**

Copyright © 1995, 1997 S-MOS Systems Inc. All rights reserved.

This document, and any text derived, extracted or transmitted from it, is the sole property of S-MOS Systems Inc. and may not be used, copied, transmitted or otherwise made available to any other person, unless specifically allowed under license agreement with S-MOS Systems Inc. If furnished under a license, this document may be used and copied only in accordance with the terms of such license, and with the inclusion of this copyright notice. No title or ownership of the technology herein is transferred.

The information in this document is subject to change without notice and should not be construed as a commitment by S-MOS Systems Inc. This document does not necessarily describe any current planned or future product by S-MOS Systems Inc., nor does it represent any commitment to implement any such product.

**THIS PAGE LEFT BLANK**

---

## Table of Contents

<b>1</b>	<b>INTRODUCTION</b> . . . . .	<b>5</b>
1.1	Reference Material . . . . .	5
<b>2</b>	<b>CONFIGURATION EQUATIONS</b> . . . . .	<b>6</b>
2.1	Example . . . . .	6
2.1.1	Input Clock Requirement Calculation . . . . .	6
2.2	SRAM Size and Access Time Requirements . . . . .	7
2.2.1	SRAM Size . . . . .	7
2.2.2	SRAM Access Time . . . . .	7
<b>3</b>	<b>CONCLUSIONS</b> . . . . .	<b>7</b>
<b>4</b>	<b>IMPLEMENTATION</b> . . . . .	<b>8</b>
4.1	16-Bit Display Memory Interface . . . . .	8
4.1.1	Configuration Options . . . . .	8
4.1.2	Register Settings . . . . .	9

## List of Figures

Figure 1:	16-Bit Memory Configuration Example . . . . .	8
-----------	---	---

**THIS PAGE LEFT BLANK**

## 1 INTRODUCTION

The SED1353 is a highly configurable general purpose LCD controller. The LCD panel frame-rate, resolution, and number of colors / gray shades all determine the memory and input clock requirements. This application note describes the equations used to determine the various parameters. An example resolution and desired frame-rate will be selected and used to determine the remaining variables.

### 1.1 Reference Material

Refer to the SED1353 Hardware Functional Specification (X18A-A-001-xx) for complete AC timing details.

## 2 CONFIGURATION EQUATIONS

This application note will follow one example through all the required calculations. For a complete description of all formula and associated parameters refer to the Hardware Functional Specification.

### 2.1 Example

LCD panel resolution:	320x240
LCD panel configuration:	8-bit, single panel, single drive panel
LCD colors:	256
Desired frame-rate:	70Hz
SED1353 operating voltage:	3.3v

#### 2.1.1 Input Clock Requirement Calculation

For a frame rate of 70Hz, the input clock (or pixel clock) frequency can be calculated as following:

$$f_{OSC} = \text{input clock}$$

$$f_{OSC} = \text{FrameRate} \times (\text{NumberOfHorizontalPixels} + \text{PHNDP} + \text{DHNDP}) \times (\text{NumberOfVerticalLines} + 4)$$

Where DHNDP is Default Horizontal Non-Display Period in term of pixels:

DHNDP = 16 pixels in gray shade display modes, and  
DHNDP = 32 pixels in BW display mode and in color display modes.

Where PHNDP is Programmable Horizontal Non-Display Period in term of pixels:

PHNDP = 0 pixels when AUX[0C] = 0, and

$$\text{PHNDP} = \frac{(\text{AUX}[0C] + 1) \times (\text{MemoryInterfaceWidth})}{(\text{BitsPerPixel})} \text{ pixels when AUX}[0C] \text{ not equal to zero.}$$

#### Note

For this example we will use DHNDP = 32, PHNDP = 0

Therefore:

$$f_{OSC} = 70 * (320 + 32) * (240 + 4)$$

$$f_{OSC} = 6.0 \text{ MHz}$$



## 2.2 SRAM Size and Access Time Requirements

### 2.2.1 SRAM Size

$$\text{Memory Size (bytes)} = \frac{(\text{Horizontalpixels}) \times (\text{Verticallines}) \times (\text{BitsPerPixel})}{8}$$

i.e., 256 colors = 8 bits / pixel, therefore 1 byte (8 bits) = 1 pixel

Therefore:

$$\text{Memory size (bytes)} = (320 * 240) * 8 / 8$$

Memory size (bytes) = 76.8 K bytes.

#### Note

For a detailed description of the memory size requirement, see section 9.4 of the SED1353 Hardware Functional Specification, drawing office number X18A-A-001-xx.

### 2.2.2 SRAM Access Time

To support 256 color modes the SED1353 must be configured to support a 16-bit data path into display memory (SRAM).

For 16-bit display memory interface the required SRAM access time must be:

$$\text{SRAM Access time} \leq 1/f_{\text{OSC}} - 40\text{nsec. (3.3v specification)}$$

Therefore using a 6.0 Mhz input clock:

SRAM access time must be  $\leq 127$  ns.

#### Note

For a detail description of the SRAM access time, see section 9.2 of the SED1353 Hardware Functional Specification, drawing office number X18A-A-001-xx.

## 3 CONCLUSIONS

To support a 320x240 256 color panel at 70 Hz refresh, you require a 6.0 MHz input clock, and 76.8K Bytes of 127nsec access time SRAM.

## 4 IMPLEMENTATION

### 4.1 16-Bit Display Memory Interface

Since 76.8K bytes with at least 127ns access time SRAM is required, one 64Kx16 byte SRAM with 120ns access time will be used for this example.

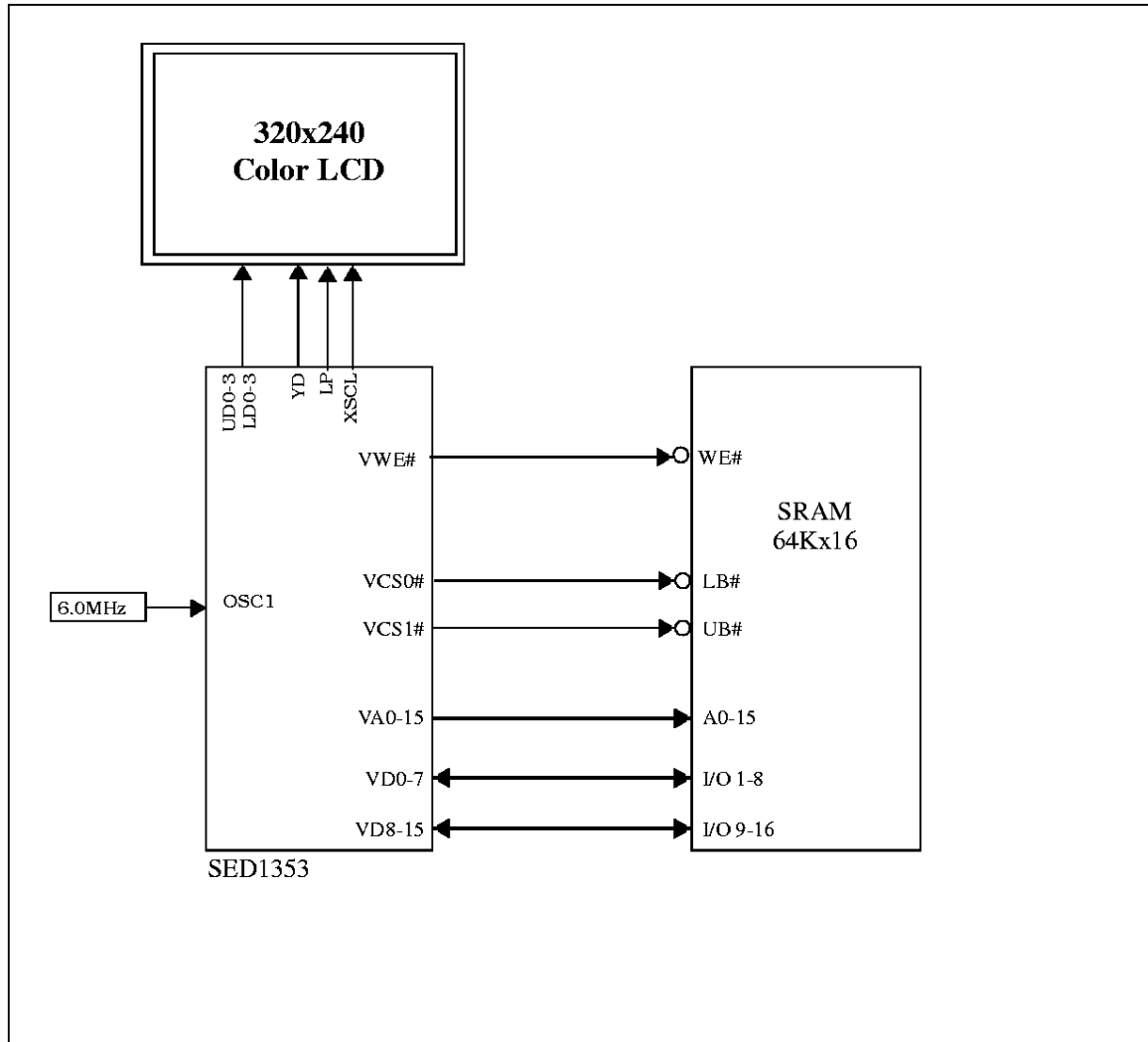

Figure 1: 16-Bit Memory Configuration Example

#### 4.1.1 Configuration Options

VD0 = pull-up (with a 10K resistor) for 16-bit bus interface.

Other option settings are not related to this implementation.

### 4.1.2 Register Settings

AUX[0] = 0000 0000	not in test mode
AUX[1] = 1011 100x	8-bit single panel, 256 color, 16-bit display memory interface
AUX[2] = 1001 1111	horizontal resolution = 320 ; 256 colors = 1 pixels per byte; 1 pixels per fetch
AUX[3] = 0000 0110	not in power save modes
AUX[4] = 1110 1111	total 240 scan lines
AUX[5] = 0000 0000	WF = 0
AUX[6] = 0000 0000	
AUX[7] = 0000 0000	default starting address at 0000h (with AUX[6])
AUX[8] = xxxx xxxx	don't care when not using split screen
AUX[9] = xxxx xxxx	don't care when not using split screen
AUX[A] = 1110 1111	together with AUX[B] bit1-0, should be the same as or larger than AUX[5] bit1-0 and
AUX[B] = xxxx xx00	AUX[4] when not using split screen
AUX[D] = 0000 0000	no virtual screen

x = don't care

A sample of values for the Look Up Table to produce 256 colors is shown below;

RED: [00 02 04 06 09 0B 0D 0F]0F 0D 0B 09 06 04 02 00

GREEN:[00 02 04 06 09 0B 0D 0F]0F 0D 0B 09 06 04 02 00

BLUE: [00 05 0A 0F]0F 0A 05 00 01 06 09 0E 0D 09 04 02

#### Note

Refer to SED1353 Programming Notes and Examples, X18A-G-002-xx, for further information.

**THIS PAGE LEFT BLANK**



## **SED1353 Dot Matrix Graphics LCD Controller**

# **SED1353F0A / SED1352F0B Comparison**

**Drawing Office No. X18A-G-008-01**

Copyright © 1997 S-MOS Systems Inc. All rights reserved.

This document, and any text derived, extracted or transmitted from it, is the sole property of S-MOS Systems Inc. and may not be used, copied, transmitted or otherwise made available to any other person, unless specifically allowed under license agreement with S-MOS Systems Inc. If furnished under a license, this document may be used and copied only in accordance with the terms of such license, and with the inclusion of this copyright notice. No title or ownership of the technology herein is transferred.

The information in this document is subject to change without notice and should not be construed as a commitment by S-MOS Systems Inc. This document does not necessarily describe any current planned or future product by S-MOS Systems Inc., nor does it represent any commitment to implement any such product.

**THIS PAGE LEFT BLANK**

# 1 SED1353F0A / SED1352F0B Comparison

The SED1353F0A is pin compatible with, and includes all features of the SED1352F0B. This allows an easy upgrade path for the system designer, both from the hardware and software aspect. The purpose of this document is to briefly describe the differences between these two controllers, for further details refer to the individual Hardware Functional Specifications.

## 1.1 Feature Comparison

Feature	SED1353F0A	SED1352F0B
Color	<ul style="list-style-type: none"> <li>4 / 16 / 256 colors</li> </ul>	<ul style="list-style-type: none"> <li>Not available</li> </ul>
Monochrome	<ul style="list-style-type: none"> <li>Black-and-White</li> <li>4 / 16 Gray Shades</li> </ul>	<ul style="list-style-type: none"> <li>Not available</li> <li>4 / 16 Gray Shades</li> </ul>
Display Data Formats	<ul style="list-style-type: none"> <li>4 / 8-bit, Single / Dual Monochrome panel support</li> <li>4 / 8 / 16-bit Single / Dual Color panel support (Note)</li> </ul>	<ul style="list-style-type: none"> <li>4 / 8-bit, Single / Dual Monochrome panel support</li> <li>Not available</li> </ul>
Programmable Horizontal Non-Display Period	<ul style="list-style-type: none"> <li>Yes</li> </ul>	<ul style="list-style-type: none"> <li>Fixed</li> </ul>
Look-Up Tables	<ul style="list-style-type: none"> <li>3x16 position, 4-bit wide Look-Up Tables</li> </ul>	<ul style="list-style-type: none"> <li>1x16 position, 4-bit wide Look-up Table</li> </ul>
Revision Code	<ul style="list-style-type: none"> <li>2-bit fixed</li> </ul>	<ul style="list-style-type: none"> <li>1-bit fixed</li> </ul>

**Note**

16-bit color panel support is provided by the SED1353F0A using external logic.

All other features not mentioned above are supported by both controllers. See the SED1353F0A Hardware Functional Specification, X18A-A-001-xx, and the SED1352F0B Hardware Functional Specification, X16-SP-001-xx, for further details.

## 1.2 SED1353F0A Register Changes / Additions From The SED1352F0B

See the SED1353F0A Hardware Functional Specification, X18A-A-001-xx, for details on these registers.

### AUX[01h]

- bit 2 LCD Data Width bit 0
- bit 3 Gray Shade / Color

### AUX[03h]

- bit 1 Color Mode
- bit 2 BW / 256 Colors
- bit 3 LCD Data Width bit 1

### AUX[0Ch]

- bit 0:7 Horizontal Non-Display Period

### AUX[0Eh]

- bit 4 ID Bit / RGB Index Bit 0
- bit 5 ID Bit / RGB Index Bit 1
- bit 6 Green Bank Bit 0
- bit 7 Green Bank Bit 1

### AUX[0Fh]

- bit 4 Blue Bank Bit 0
- bit 5 Blue Bank Bit 1
- bit 6 Red Bank Bit 0
- bit 7 Red Bank Bit 1