

N8300P-0085	<b>N Jack Solder Clamp For RG405; 11GHz VSWR 1.2</b>	<b>50Ω</b>
-------------	--	------------

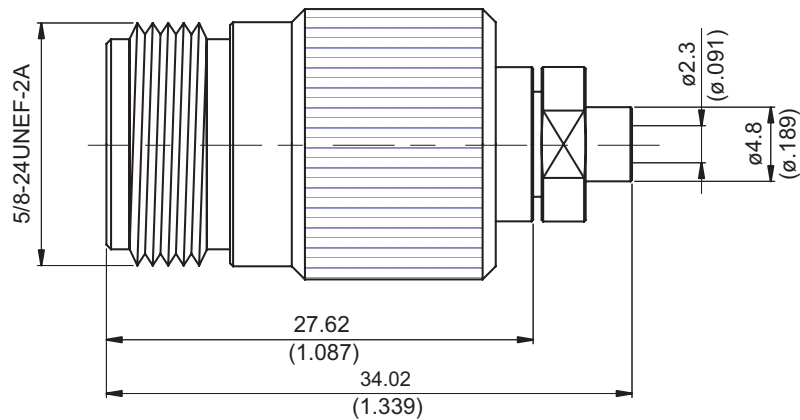

Parts	Material	Plating (Micro-inch)
Solder Clamp Nut	Brass	Gold 4 Over Nickel-Phosphorus Alloy 80 Over Copper 20
Contact Body	Brass	Tin-Zinc-Copper-Alloy 100 Over Copper 50
Contact Pin	Beryllium Copper	Gold 4 Over Nickel-Phosphorus Alloy 80 Over Copper 20
Insulator	Teflon	
Body	Brass	Tin-Zinc-Copper-Alloy 100 Over Copper 50

Suitable Cables: Semi-rigid.085

**This part number complies with RoHS.**



**Notice: JYEBAO reserves the right to make modifications deemed appropriate.**

N	N8300P-0085																		
<div data-bbox="167 344 568 394" style="border: 1px solid black; padding: 2px;">Interface</div> <p>MIL-STD-348B</p>																			
<div data-bbox="167 510 568 560" style="border: 1px solid black; padding: 2px;">Electrical Data</div> <table border="0" style="width: 100%;"> <tr> <td style="width: 60%;">Impedance</td> <td>50Ω</td> </tr> <tr> <td>Frequency range</td> <td>DC to 11GHz</td> </tr> <tr> <td>VSWR</td> <td>≦ 1.2 (DC to 11GHz)</td> </tr> <tr> <td>Insertion loss</td> <td>≦ 0.05 x √f(GHz) dB</td> </tr> <tr> <td>Insulation resistance</td> <td>≧ 5000MΩ</td> </tr> <tr> <td>Contact resistance inner conductor</td> <td>≦ 1.5mΩ</td> </tr> <tr> <td>Contact resistance outer conductor</td> <td>≦ 1mΩ</td> </tr> <tr> <td>Dielectric withstanding voltage (at sea level)</td> <td>2500 V rms</td> </tr> <tr> <td>Working voltage (at sea level)</td> <td>1000 V rms</td> </tr> </table>		Impedance	50Ω	Frequency range	DC to 11GHz	VSWR	≦ 1.2 (DC to 11GHz)	Insertion loss	≦ 0.05 x √f(GHz) dB	Insulation resistance	≧ 5000MΩ	Contact resistance inner conductor	≦ 1.5mΩ	Contact resistance outer conductor	≦ 1mΩ	Dielectric withstanding voltage (at sea level)	2500 V rms	Working voltage (at sea level)	1000 V rms
Impedance	50Ω																		
Frequency range	DC to 11GHz																		
VSWR	≦ 1.2 (DC to 11GHz)																		
Insertion loss	≦ 0.05 x √f(GHz) dB																		
Insulation resistance	≧ 5000MΩ																		
Contact resistance inner conductor	≦ 1.5mΩ																		
Contact resistance outer conductor	≦ 1mΩ																		
Dielectric withstanding voltage (at sea level)	2500 V rms																		
Working voltage (at sea level)	1000 V rms																		
<div data-bbox="167 1055 568 1104" style="border: 1px solid black; padding: 2px;">Mechanical Data</div> <table border="0" style="width: 100%;"> <tr> <td style="width: 60%;">Recommended coupling nut torque</td> <td>6 to 10 inch lbs</td> </tr> <tr> <td>Coupling proof torque</td> <td>15 inch lbs</td> </tr> <tr> <td>Contact captivation-axial</td> <td>≧ 6.3 lbs</td> </tr> <tr> <td>Durability (mating)</td> <td>≧ 500</td> </tr> </table>		Recommended coupling nut torque	6 to 10 inch lbs	Coupling proof torque	15 inch lbs	Contact captivation-axial	≧ 6.3 lbs	Durability (mating)	≧ 500										
Recommended coupling nut torque	6 to 10 inch lbs																		
Coupling proof torque	15 inch lbs																		
Contact captivation-axial	≧ 6.3 lbs																		
Durability (mating)	≧ 500																		
<div data-bbox="167 1411 568 1460" style="border: 1px solid black; padding: 2px;">Environmental Data</div> <table border="0" style="width: 100%;"> <tr> <td style="width: 60%;">Temperature range</td> <td>-65°C to +165°C</td> </tr> <tr> <td>Thermal shock</td> <td>MIL-STD-202, Method 107, Condition B</td> </tr> <tr> <td>Moisture resistance</td> <td>MIL-STD-202, Method 106</td> </tr> <tr> <td>Corrosion</td> <td>MIL-STD-202, Method 101, Condition B</td> </tr> <tr> <td>RoHS</td> <td>Compliant</td> </tr> </table>		Temperature range	-65°C to +165°C	Thermal shock	MIL-STD-202, Method 107, Condition B	Moisture resistance	MIL-STD-202, Method 106	Corrosion	MIL-STD-202, Method 101, Condition B	RoHS	Compliant								
Temperature range	-65°C to +165°C																		
Thermal shock	MIL-STD-202, Method 107, Condition B																		
Moisture resistance	MIL-STD-202, Method 106																		
Corrosion	MIL-STD-202, Method 101, Condition B																		
RoHS	Compliant																		
<div data-bbox="167 1762 568 1812" style="border: 1px solid black; padding: 2px;">Tooling</div> <table border="0" style="width: 100%;"> <tr> <td style="width: 60%;">Soldering fixture</td> <td>ST-008</td> </tr> <tr> <td>Insert for .085 semi-rigid cable</td> <td>ST-009</td> </tr> <tr> <td>Locator tool</td> <td>ST-011 &amp;ST-N83</td> </tr> </table>		Soldering fixture	ST-008	Insert for .085 semi-rigid cable	ST-009	Locator tool	ST-011 &ST-N83												
Soldering fixture	ST-008																		
Insert for .085 semi-rigid cable	ST-009																		
Locator tool	ST-011 &ST-N83																		

Notice: JYEBAO reserves the right to make modifications deemed appropriate.

# JYE BAO CO., LTD.

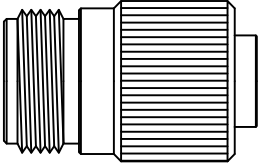
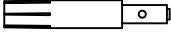
## CABLE ASSEMBLY INSTRUCTION

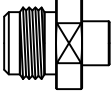
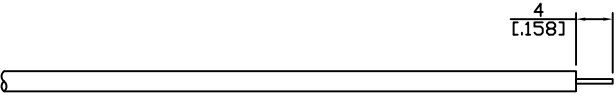
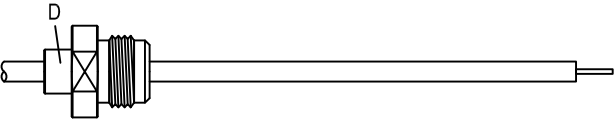
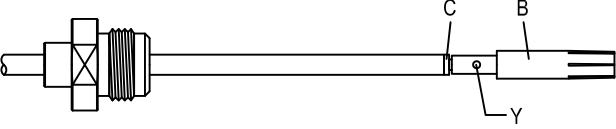
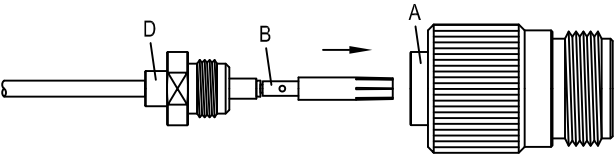
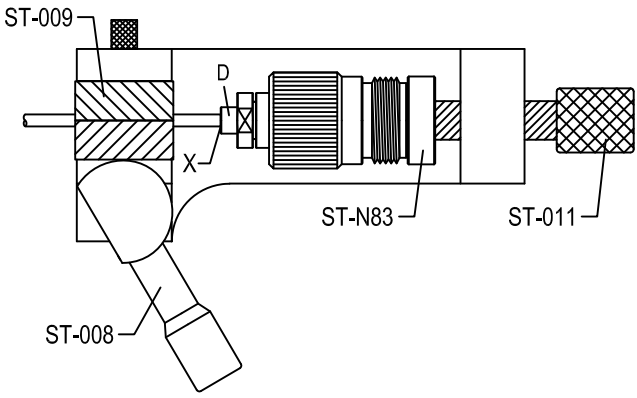
N8300P-0085	DATE	2021/01/15	REV	—
A	B	C	D	
				
BODY	CONTACT PIN	INSULATOR	SOLDER NUT	
DIAGRAM		ASSEMBLY INSTRUCTION		
		Step 1: STRIP AS SHOWN.		
		Step 2: SLIDE SOLDER NUT " D " OVER CABLE.		
		Step 3: PUT INSULATOR " C " AND PIN " B " ON CENTER CONDUCTOR AND SOLDER IN " Y ".		
		Step 4: PUSH PIN " B " INTO CONNECTOR BODY " A ". Step 5: SCREW SOLDER NUT " D " ON THE CONNECTOR BODY " A ".		
		Step 6: USE SOLDERING FIXTURE " ST-008 ", INSERT TOOL " ST-009 " AND LOCATOR TOOL " ST-011 " AND " ST-N83 " TO THE CONNECTOR. SOLDER IN " X ".		
<p>This part number complies with RoHS.</p> <p>Notice: JYEBAO reserves the right to make modifications deemed appropriate.</p>				
APPROVED	CHECKED	DRAWING		<i>Albert</i>

# N8300P-0085

