

SP8755

1200MHz ÷ 64

The SP8755 is a divide by 64 prescaler which operates from a standard 5V TTL supply and will drive TTL directly. The SP8755A operates over the full military temperature range (-55°C to +125°C).

FEATURES

- TTL Compatible Output
- AC Coupled Input (Internal Bias)

QUICK REFERENCE DATA

- Supply Voltage: 5V
- Power Consumption: 270mW
- Temperature Range: -55°C to +125°C (A Grade)
-30°C to +70°C (B Grade)

ABSOLUTE MAXIMUM RATINGS

Supply voltage	8V
Output current	±30mA
Storage temperature range	-65°C to +150°C
Max. junction temperature	+175°C
Max. clock input voltage	2.5V p-p

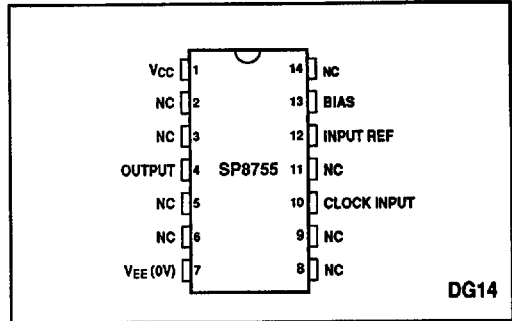

Fig. 1 Pin connections - top view

ORDERING INFORMATION

- SP8755 A DG
- SP8755 B BG
- SP8755 NA 1C
- 5962-88684 (SMD)

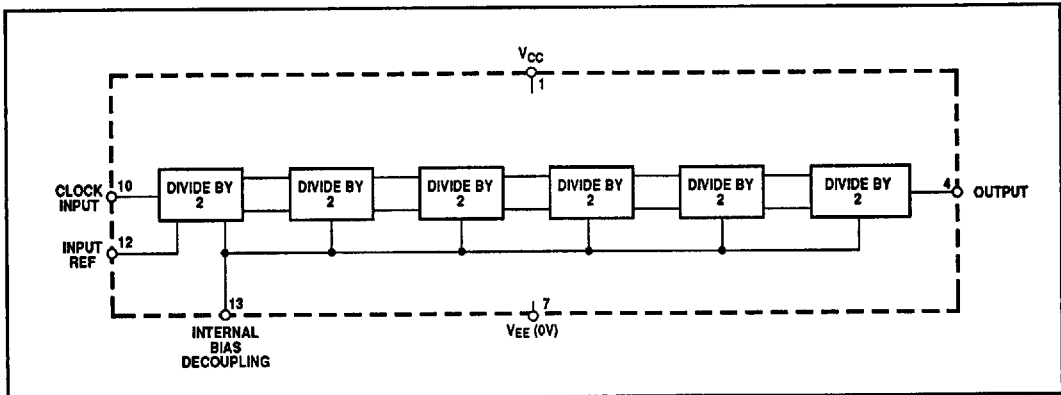

Fig. 2 Functional diagram

ELECTRICAL CHARACTERISTICS

Unless otherwise stated, the Electrical Characteristics are guaranteed over specified supply, frequency and temperature range
 Supply voltage, $V_{CC} = 5.0V \pm 0.25V$, $V_{EE} = 0V$
 Temperature, $T_{AMB} = -55^{\circ}C$ to $+125^{\circ}C$ (A Grade), $-30^{\circ}C$ to $+70^{\circ}C$ (B Grade)

Characteristic	Symbol	Value		Units	Grade	Conditions
		Min.	Max.			
Maximum frequency (sinewave input)	f_{MAX}	1.2		GHz	SP8755A	Input = 600-1200mV p-p
	f_{MAX}	1.2		GHz	SP8755B	
Minimum frequency (sinewave input)	f_{MIN}		100	MHz	Both	Input = 600-1200mV p-p
Power supply current	I_{CC}		75	mA	Both	
Output high voltage	V_{OH}	2.5		V	Both	
Output low voltage	V_{OL}		0.45	V	Both	Sink current = 5mA

NOTES

1. The test configuration for dynamic testing is shown in Fig 5.
2. Above characteristics are not tested at 25°C only (tested at low and high temperatures only).

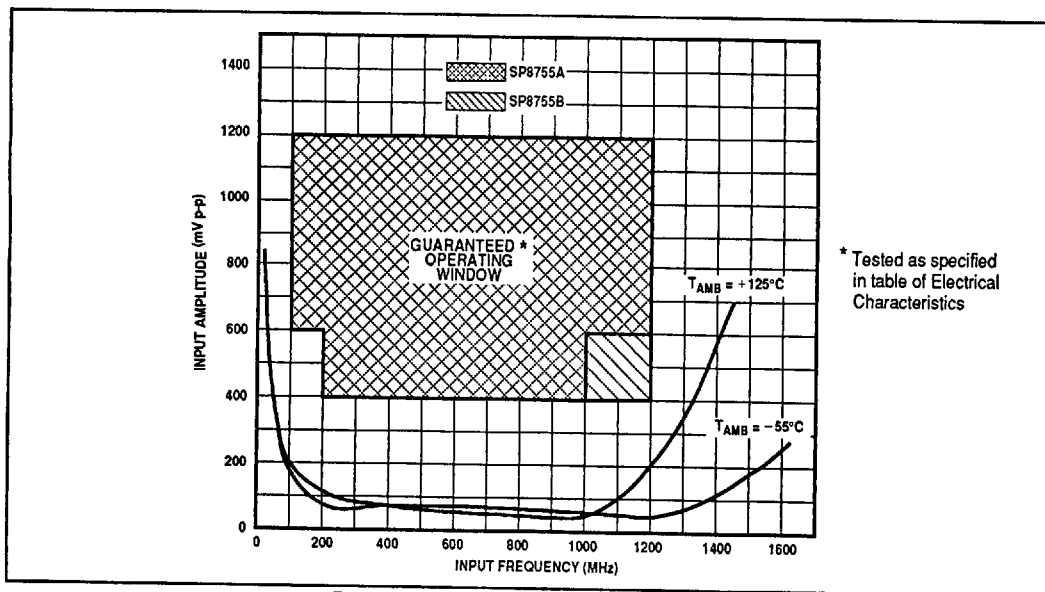

Fig. 3 Typical input characteristic of SP8755A/B

* Tested as specified in table of Electrical Characteristics

OPERATING NOTES

1. The clock input is biased internally and is connected to the signal source via a capacitor. The input signal path is completed by an input reference decoupling capacitor which is connected to ground.
2. If no signal is present the device will self-oscillate. If this is undesirable it may be prevented by connecting an 18kΩ

- resistor between the input and V_{EE} (i.e. from pin 10 to pin 7). This will reduce sensitivity by approximately 100mV.
3. The device will operate down to DC but input slew rate must be better than 100V/μs.
4. The output is a standard totem pole TTL and can therefore be interfaced directly to TTL.

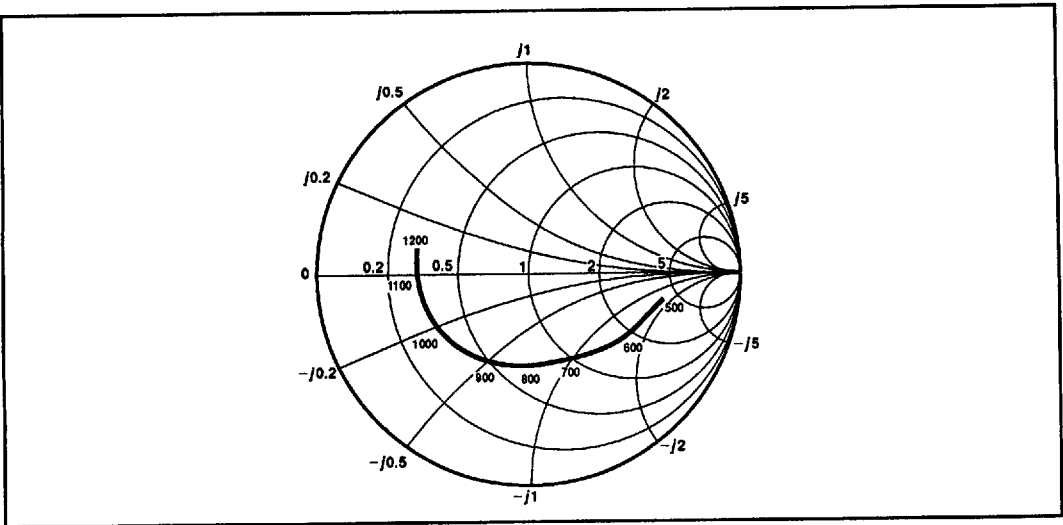

Fig. 4 Typical input impedance. Test conditions: supply voltage = 5.2V, ambient temperature = 25°C, frequencies in MHz, Impedances normalised to 50Ω

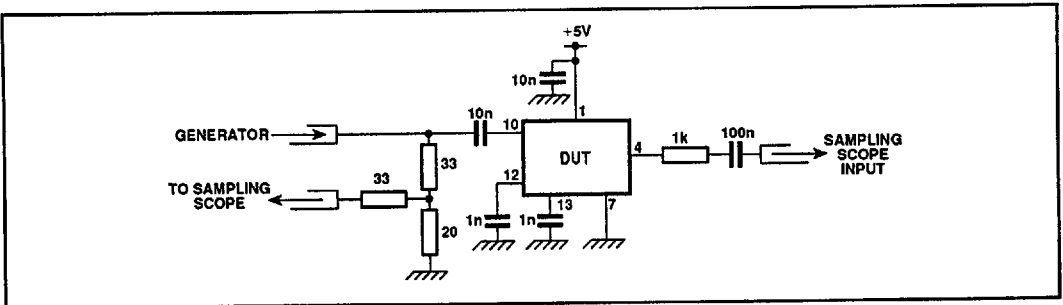

Fig. 5 Test circuit

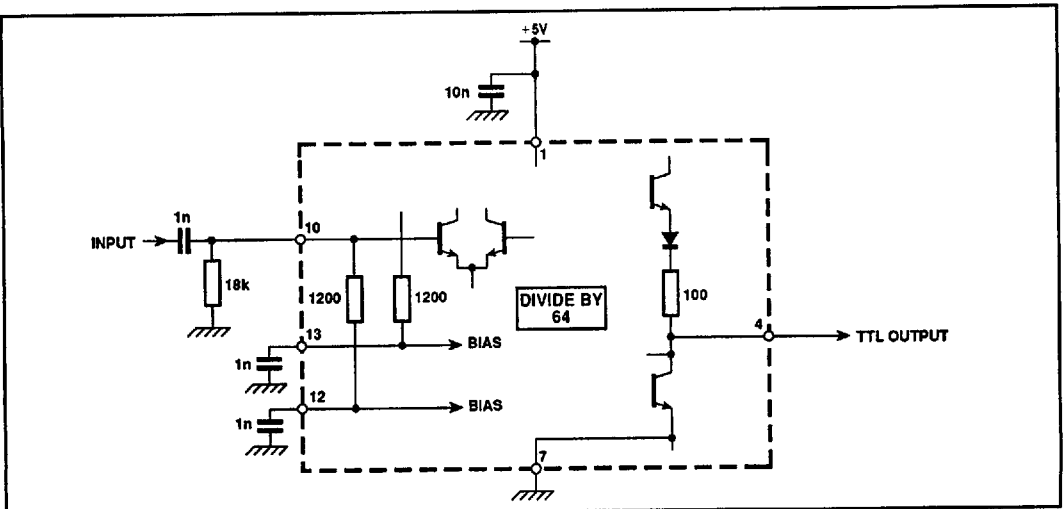

Fig. 6. Typical application circuit showing interfacing