

# PGT 603 04

## Optical Transmitter Module

### for STM-16 SH/OC-48 IR

The transmitter module is intended for use at SDH and SONET bit rates. The device meets all present requirements in the ITU-T (G.957, G.958) and Bellcore (GR-253-CORE) recommendations.

The module contains Franz-Keldysh modulator integrated DFB laser, minimizing chirp and providing long transmission span. Path penalty is typically 0.3 dB over a 40 km standard SM fiber. The high integration level gives a compact and easy to use solution for 2.5 Gbit systems while maintaining low power consumption.

The laser bias is externally accessible for monitoring of the performance. A power alarm is activated when the average optical power cannot be maintained within specification.

A laser shut-down is also provided according to SDH/SONET requirements. Ericsson Components fiber optic products are qualified to Ericsson internal standard which use MIL-STD-883 test methods.

#### Features

- Integrated DFB-EA laser
- Built-in optical isolator
- Typical output power -3 dBm
- Low power consumption
- Size (55 x 100 x 17 mm)
- CMOS alarm output
- Clocked reshape

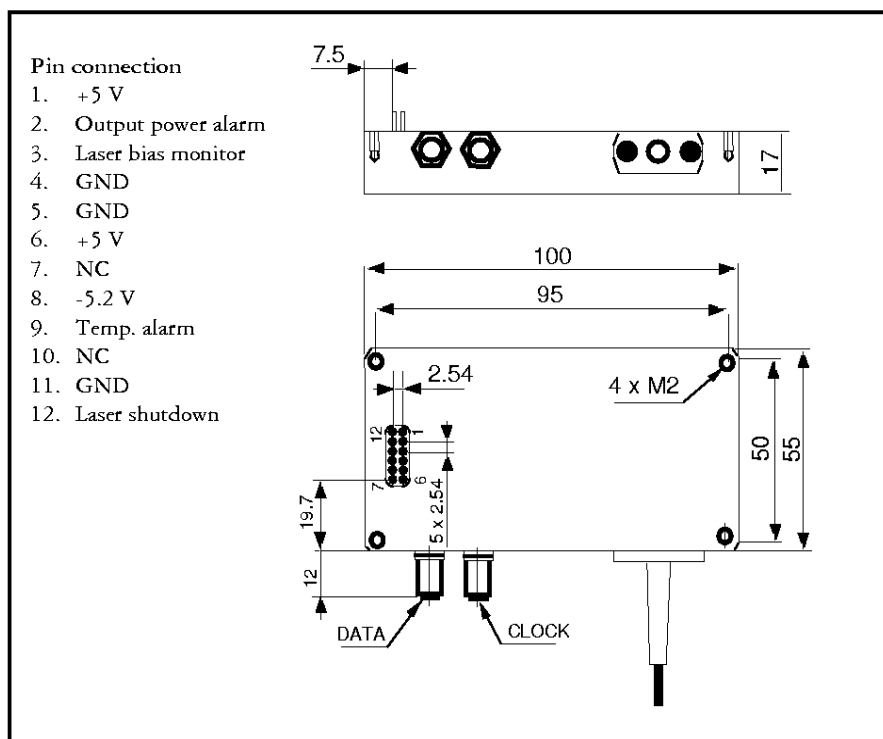
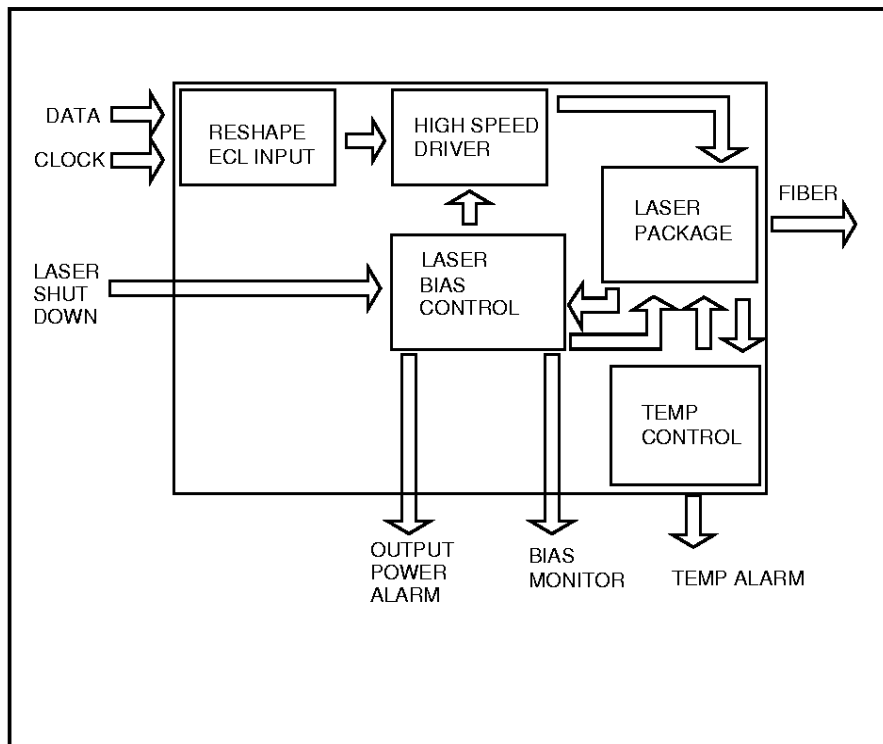

## Optical and Electrical Specification

Item	PGT 603 04	Unit
Bit rate	2488.32	Mbit/s
Average output power	-5.0 to 0.0	dBm
Peak wavelength	1535-1565	nm
Spectral width	< 1.0	nm
Side mode suppression	> 30	dB
Extinction ratio	> 8.2	dB
Eye diagram	G.957	ITU-T
Thermoelectric cooler	yes	
Power consumption	< 6	W
Power supply	+5.0 ± 0.25 -5.2 ± 0.25	V
Operating case temperature	-40 to +70	°C

### Electrical Interface

Input signals, Clock and Data	AC coupled with 50 ohm termination
Laser shut-down	CMOS, active high.
Laser bias monitor	Analog voltage, set to 1.0 V at delivery (referring to output power of -3 dBm)
Laser control circuitry out of range	CMOS, active high when the laser control circuitry is out of range and no longer can maintain laser output power within specification.
Temperature alarm	CMOS, active high when temp control circuitry cannot maintain temperature of laser within specification

### Quality Assurance

Ericsson Components commitment to quality has been proved through a decade of semiconductor device production and has been confirmed to ISO 9001. These products are qualified according to the intention of Bellcore (TR-NWT-000468) and supplied with final test data.

### Connector Options

FC/PC

SC

(Other connectors available on request)

Ericsson Components  
 Phone: +46 (8) 757 4402  
 Fax: +46 (8) 757 4621  
**American Sales Region**  
 Phone: +1 (972) 583 7236  
 Fax: +1 (972) 583 5005  
**European Sales Region**  
 Phone: +44 (1793) 488 300  
 Fax: +44 (1793) 488 301

Information given in this data sheet is believed to be accurate and reliable. However no responsibility is assumed for the consequences of its use nor for any infringement of patents or other rights of third parties which may result from its use. No license is granted by implication or otherwise under any patent or patent rights of Ericsson Components AB. These products are sold only according to Ericsson Components general conditions of sale, unless otherwise confirmed in writing.



Specifications subject to change without notice.  
 1522-PGT 603 04 Uen Rev. B  
 © Ericsson Components AB, March, 1998