

February 1998

Engine Knock Signal Processor

Features

- Two Sensor Inputs
- Microprocessor Programmable
- Accurate and Stable Filter Elements
- Digitally Programmable Gain
- Digitally Programmable Time Constants
- Digitally Programmable Filter Characteristics
- On-Chip Clock
- Operating Temperature Range -40°C to 125°C

Applications

- Engine Knock Detector Processor
 - Analog Signal Processing where Controllable Filter Characteristics are Required

Ordering Information

PART NUMBER	TEMP. RANGE (°C)	PACKAGE	PKG. NO.
HIP9010AB	-40 to 125	20 Ld SOIC (W)	M20.3

Description

The HIP9010 is used to provide a method of detecting premature detonation or "Knock" in automotive engines.

A block diagram of this IC is shown in Figure 1. The chip alternately selects one of the two sensors mounted on the engine block. Two programmable bandpass filters process the signal from both sensors, and divides the signal into two channels. When the engine is not knocking, programmable gain adjust stages are set to ensure that both the reference channel and the knock channel contain similar energies. This technique ensures that the detection system is comparatively immune to changes in the engine background noise level. When the engine is knocking, the energy in the knock channel increases.

An active, full wave rectifier detects energy in each channel. During integration, the energy from the reference channel is subtracted from the energy in the knock channel. The result is an analog voltage, whose output level is proportional to the engine knock.

The chip is under microprocessor control via an SPI interface bus.

Pinout

HIP9010
(SOIC)
TOP VIEW

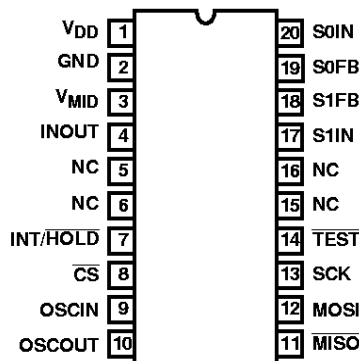

Simplified Block Diagram

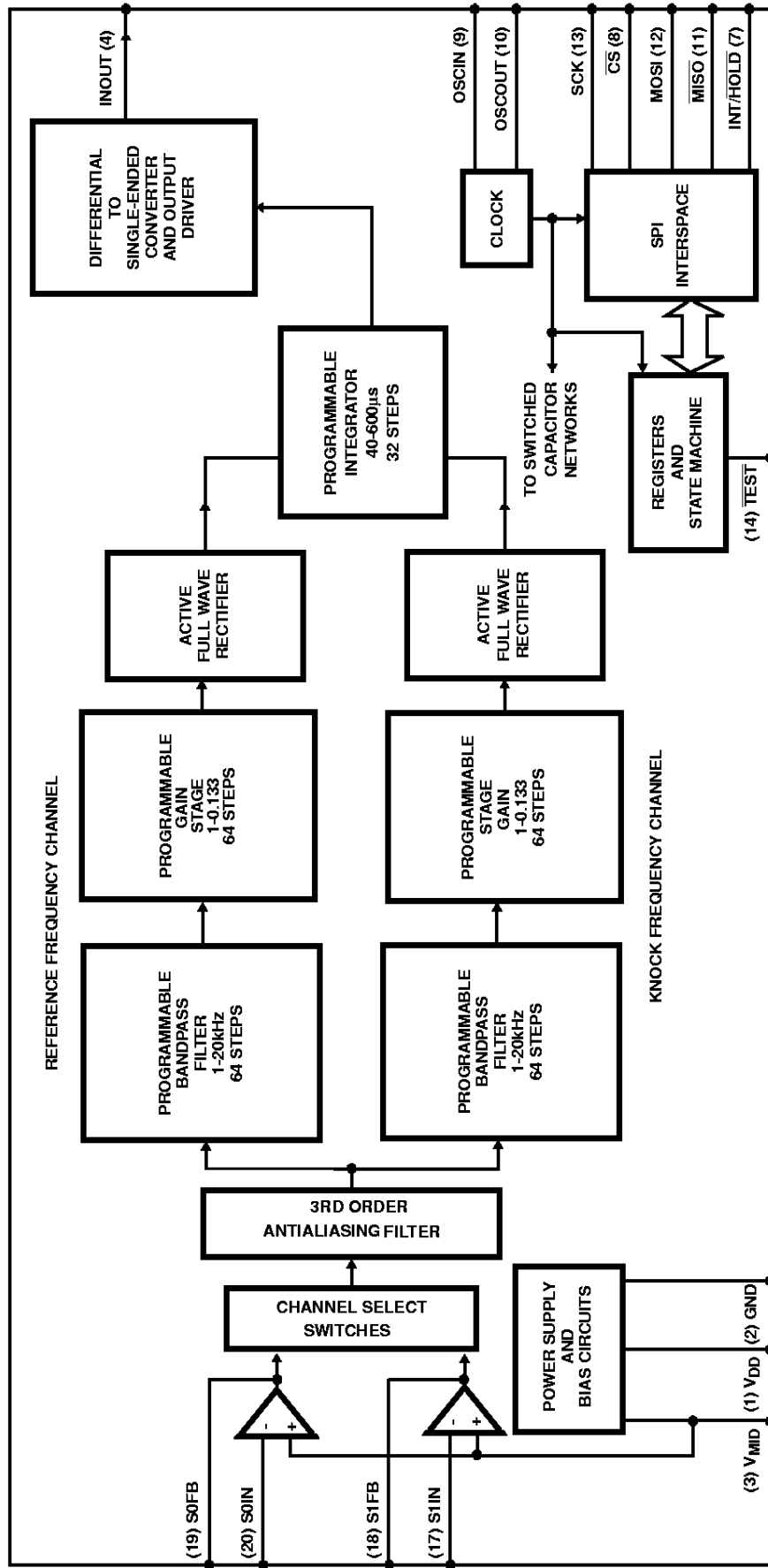

FIGURE 1.

HIP9010

Absolute Maximum Ratings

DC Logic Supply, V_{DD} -0.5V to +7.0V
 Output Voltage, V_O -0.5V to +7.0V
 Input Voltage, V_{IN} +7V Max.

Operating Conditions

Temperature Range -40°C to 125°C

Thermal Information

Thermal Resistance (Note 1) θ_{JA}
 SOIC Package 105°C/W
 Maximum Storage Temperature Range, T_{STG} -65°C to 150°C
 Maximum Junction Temperature 150°C
 Maximum Lead Temperature (Soldering) 300°C
 At distance 1/16in ± 1/32in (1.59mm ± 0.79mm) from case
 for 10s max (SOIC - Lead Tips Only)

CAUTION: Stresses above those listed in "Absolute Maximum Ratings" may cause permanent damage to the device. This is a stress only rating and operation of the device at these or any other conditions above those indicated in the operational sections of this specification is not implied.

NOTE:

1. θ_{JA} is measured with the component mounted on an evaluation PC board in free air.

Electrical Specifications $V_{DD} = 5V, \pm 5\%$, GND = 0V, Clock Frequency 4MHz, $\pm 0.5\%$, $T_A = -40^\circ\text{C}$ to 125°C ,
 Unless Otherwise Specified.

PARAMETER	SYMBOL	TEST CONDITIONS	MIN	TYP	MAX	UNITS
DC ELECTRICAL CHARACTERISTICS						
Quiescent Supply Current	I_{DD}	$V_{DD} = 5.25V, GND = 0V$	3	7.5	12	mA
Midpoint Voltage, Pin 3	V_{MID}	$V_{DD} = 5.0V, I_L = 2mA$ Source	2.3	2.45	2.55	V
Midpoint Voltage, Pin 3	V_{MID}	$V_{DD} = 5.0V, I_L = 0mA$	2.4	2.5	2.6	V
Input Leakage, Pin 14	I_{LTEST}	Measured at $V_{DD} = 5.0V$	-	-	3	μA
Internal Pull-Up Resistance, Pin 14	R_{TEST}	$V_{DD} = 5.0V, I_{Measure} = 15\mu A$	30	100	200	K Ω
Leakage of Pins 7, 8, 12 and 13	I_L	Measured at GND and $V_{DD} = 5V$	-	-	± 3	μA
Low Input Voltage, Pins 7, 8, 12 and 13	V_{IL}		-	-	30	% of V_{DD}
High Input Voltage, Pins 7, 8, 12 and 13	V_{IH}		70	-	-	% of V_{DD}
Low Level Output, Pin 11	V_{OL}	$I_{SOURCE} = 4mA$	0.01	-	0.30	V
Leakage Pin 11	I_L	Measured at GND and $V_{DD} = 5V$	-	-	± 10	μA
Low Level Output, Pin 10	V_{OL}	$I_{SOURCE} = 500\mu A, V_{DD} = 5V$	-	-	1.5	V
High Level Output, Pin 10	V_{OH}	$I_{SINK} = -800\mu A, V_{DD} = 5V$	4.4	-	-	V
INPUT AMPLIFIERS						
S0FB and S1FB High Output Voltage	V_{OUTHI}	$100\mu A I_{SINK}, V_{DD} = 5V$	4.7	4.9	-	V
S0FB and S1FB Low Output Voltage	V_{OUTLO}	$100\mu A I_{SOURCE}, V_{DD} = 5V$	-	15	200	mV
S0FB and S1FB Closed Loop	A_{CL}	Input Resistor = 1M Ω , Feedback Resistor = 49.9k Ω	-25	-26	-27	dB
S0FB and S1FB Closed Loop	A_{CL}	Input Resistor = 47.5k Ω , Feedback Resistor = 475k Ω	18	20	21	dB
ANTI_ALIASING FILTER						
Response 1kHz to 20kHz, Referenced to 1kHz	BW	Test Mode, 70mV $_{RMS}$ Input to S0FB or S1FB, Output Pin 4	-	-2	-	dB
Attenuation at 180kHz Referenced to 1kHz	ATEN	Test Mode, 70mV $_{RMS}$ Input to S0FB or S1FB, Output Pin 4	-10	-15	-	dB
PROGRAMMABLE FILTERS						
Peak to Peak Voltage Output	V_{OUTP-P}	Run Mode	3.5	4.0	-	V_{P-P}
Filters Q (Note 2)	Q	Run Mode	-	2.5	-	Q

HIP9010

Electrical Specifications $V_{DD} = 5V, \pm 5\%$, $GND = 0V$, Clock Frequency 4MHz, $\pm 0.5\%$, $T_A = -40^\circ C$ to $125^\circ C$, Unless Otherwise Specified. **(Continued)**

PARAMETER	SYMBOL	TEST CONDITIONS	MIN	TYP	MAX	UNITS
PROGRAMMABLE GAIN AMPLIFIERS						
Percent Amplifier Gain Deviation Per Table 2	%G	Run Mode	-	± 1	-	%
INTEGRATOR						
Integrator Offset Voltage	INTGV _{IO}	By Design	-	0.1	-	mV
Integrator Reset Voltage	V _{RESET}	Pin 4 Voltage at Initiation of Integration Cycle. $V_{DD} = 5V$	430	500	570	mV
Integrator Droop after 500 μ s	V _{DROOP}	Hold Mode, Pin 7 = 0V, $V_{DD} = 5V$, Pin 4 set to 20% to 80% of V_{DD}	-	± 3	± 50	mV
OUTPUT AND SAMPLE AND HOLD						
Differential to Single Ended Converter Offset Voltage	DIFV _{IO}	By Design	-	0.1	-	mV
Change in Converter Output	DIFOUT	Run Mode, 500 μ A, Sinking to No Load	-	± 1	± 3	mV
SYSTEM GAIN DEVIATION						
Gain Deviation from "Ideal Equation" Correlation, Factor - 5.0%	$V_{OUT} - V_{RESET}$	Run Mode, maximum signal output from Input Amplifier $< 2.25V_{P-P}$, Equation Output $\times 0.95 +$ Device Reset Voltage. For Total $V_{OUT} \leq 4.7V$	-8%, $\pm 100mV$	Equation $\times 0.95 - V_{RESET}$	8%, $\pm 100mV$	V

NOTE:

2. $Q = f_O/BW$, Where: f_O = Center Frequency, BW = 3dB bandwidth.

Ideal Equation

$$INTOUT(\text{volts}) = \text{Input signal } (V_{P-P}) \times \frac{R_F}{R_{IN}} \left[\left(G_K \times 1.273 \times \frac{N}{TC \text{ (ms)} \times f_Q \text{ (kHz)}} \right) - \left(G_R \times 1.273 \times \frac{N}{TC \text{ (ms)} \times f_Q \text{ (kHz)}} \right) \right] + V_{RESET}$$

When the two filters are set to the same frequency and the input signal is present for the periods T_{IN} , then:

$$INTOUT(\text{volts}) = \text{Input signal } (V_{P-P}) \times \frac{R_F}{R_{IN}} \left[\left(1.273 \times \frac{T_{IN}}{TC} (G_K - G_R) \right) \right] + V_{RESET}$$

G_R and G_K = Programed Gain of Reference and Knock channels.

T_{IN} = Time input signal is present In ms.

T_C = Programmed integrator time constant ms.

N = Number of cycles of input signal.

f_Q = Frequency of input signal. Assumes both filters are programmed to the same frequency.

V_{RESET} = Integrator Reset Voltage.

$$1.273 = 4/\pi$$

R_F = Feedback resistor value.

R_{IN} = Signal input resistor value.

For example, assume 300mV_{P-P} input with the time constant programmed to 300 μ s and the Integration time is 1.2ms. The R_F/R_{IN} ratio is one and the Reference channel is programmed to a Gain of 0.188. The Knock channel is then automatically set to a gain of one. The input signal is continuous for the total integration time, T_{IN} .

$$INTOUT(\text{volts}) = 0.3V (V_{P-P}) \times \left[\left(1.273 \times \frac{1.2\text{ms}}{0.300\text{ms}} \times (1.000 - 0.188) \right) \right] + V_{RESET} = 1.24V + 0.500V = 1.74V$$

HIP9010

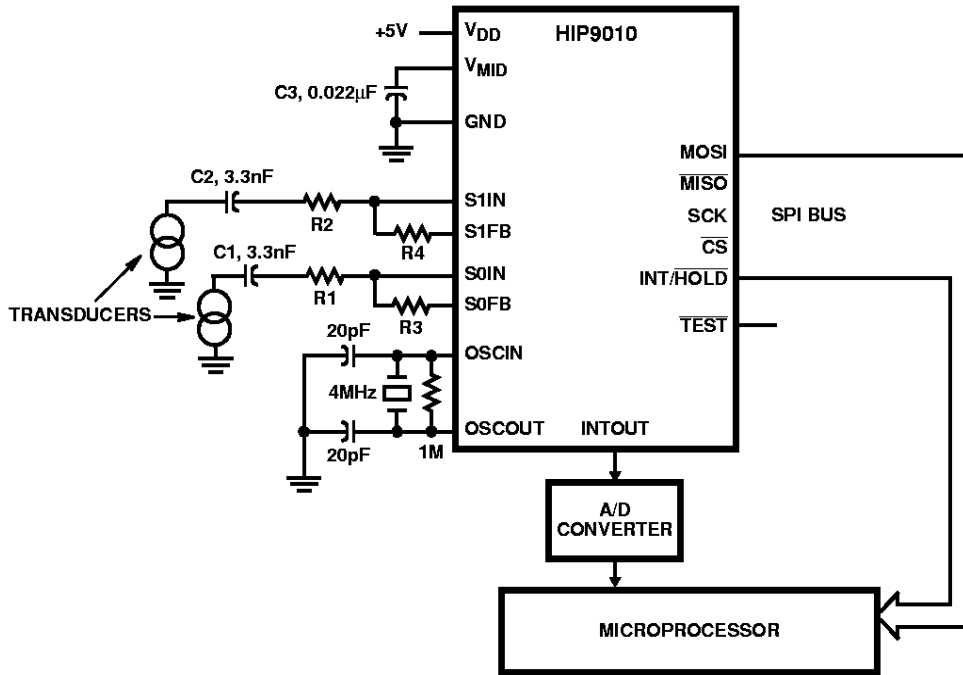

FIGURE 2. SIMPLIFIED BLOCK DIAGRAM OF THE HIP9010 IN AN AUTOMOTIVE APPLICATION

Pin Descriptions

PIN NUMBER	SYMBOL	DESCRIPTION
1	V _{DD}	Five volt power input.
2	GND	This terminal is tied to ground.
3	V _{MID}	This terminal is tied to the internal mid-supply generator and is brought out for supply bypassing by a 0.022µF capacitor.
4	INTOUT	Buffered output of the integrator.
5 and 6	NC	These terminals are not internally connected. DO NOT USE.
7	INT/HOLD	Selects whether the chip is in the Integrate Mode (Input High) or in the Hold Mode (Input Low).
8	CS	A low input on this pin enables the chip to communicate over the SPI bus.
9	OSCIN	Input to inverter used for the oscillator circuit. A 4MHz crystal or ceramic resonator is connected between this pin and pin 10. To bias the inverter, a 1.0MΩ to 10MΩ resistor is usually connected between this pin and pin 10.
10	OSCOUT	Output of the inverter used for the oscillator. See pin 9 above.
11	MISO	Output of the chip SPI data bus. It is the inversion of the chip DATAIN line. This is an open drain output. The output must be disabled by placing the CS High when the chip is not selected.
12	MOSI	Input of the chip SPI data bus. Data length is eight bits.
13	SCK	Input from the SPI clock. Normally high, the data is clocked to the chip internal circuitry on the rising clock edge.
14	TEST	A low on this pin places the chip in the test mode. For normal operation this terminal is tied high or left open.
15 and 16	NC	These terminals are not internally connected. DO NOT USE.
17	S1IN	Inverting input to sensor one amplifier. A resistor is tied from this summing input to the transducer. A second resistor is tied between this terminal and terminal 18, S1FB to establish the gain of the amplifier.
18	S1FB	Output of the sensor one amplifier. This terminal is used to apply feedback.
19	S0FB	Output of the sensor zero amplifier. This terminal is used to apply feedback.
20	S0IN	Inverting input to sensor zero amplifier. A resistor is tied from this summing input to the transducer. A second resistor is tied between this terminal and terminal 19, S0FB to establish the gain of the amplifier.

Description of the HIP9010 Operation

This IC is designed to be a universal digitally controlled, analog interface between engine acoustical sensors or accelerometers and internal combustion engine fuel management systems. Two wideband input amplifiers are provided that allow the use of two sensors that may be of the piezoelectric type that can be mounted in optimum locations on either in-line or V type engine configurations.

Output from these amplifiers is directed from a channel select switch into both digitally controlled filter and amplifier channels. Both filter bandpass and gain settings are programmable from a microprocessor. Output from the two channels is combined in a digitally programmable integrator. Integrator output is applied to a line driver for further processing by the engine fuel management system.

Broadband piezoelectric ceramic transducers used for the engine signal pickup have device capacitances in the order of 1100pF and output voltages that range from 5mV to 8V_{RMS}. During normal engine operation a single input channel is selected and applied to the filters. One filter channel processes a signal that is used to establish the background reference level. The second channel is used to observe the engine during the time interval that preignition may be expected. This information is compared with the "background" signal via the ICs integrator and will tend to cancel the background noise and accentuate noise due to engine pre-detonation. Moreover, the bandpass of filter channels can be optimized to further discriminate between engine background and combustion noise and pre-detonation noise.

A basic approach to engine pre-detonation systems is to only observe engine background during the time interval that noise is expected and if detected, retard timing. This approach does not require the sensitivity and selectivity that is needed for a continuously adjustable solution. Enhanced fuel economy and performance is obtainable when this IC is coupled with a microprocessor controlled fuel management system.

Circuit Block Description

Input Amplifiers

Two amplifiers are used to interface to the two engine sensors. These amplifiers have a typical open loop gain of 100dB, with a typical bandwidth of 2.6MHz. The common mode input voltage range extends to within 0.5V of either supply rail. The amplifier output has a similar output range.

Sufficient gain, bandwidth and output swing capability was provided to ensure that the amplifiers can handle attenuation gain settings of 20 to 1 or -26dB. This would be needed when high peak output signals, in the range of 8V_{RMS}, are obtained from the transducer. Gain settings of 10 times can also be needed when the transducers have output levels of 5mV_{RMS}.

In a typical application the input signal frequency may vary from DC to 20kHz. External capacitors are used to decouple the IC from the sensor (C1 and C2). A typical value of the capacitors is 3.3nF. Series input resistors, R1 and R2, are used to connect the inverting inputs of the amplifiers, (pins

20 and 17). Feedback resistors, R3 and R4, in conjunction with R1 and R2 are used to set the gain of the amplifiers.

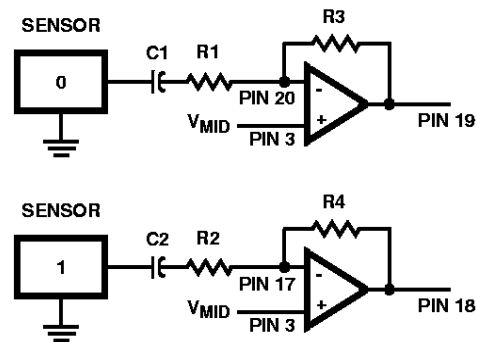

FIGURE 3. INPUT AMPLIFIER CONNECTIONS

A mid-voltage level is generated by the IC. This level is set to be half way between V_{DD} and ground. Throughout the IC this level is used as a quiet, DC reference for the circuits within the IC. This point is brought out for several reasons: it can be used as a reference voltage, and it must be bypassed to ensure that it is a quiet reference for the internal circuitry.

The input amplifiers are designed with power down capability, which, when activated disables their bias circuit and their output goes into a three-state condition. This is very important during the test mode, in which the output terminals of the amplifiers are driven by the outside world with test signals.

Antialiasing Filter

The IC has a 3rd order Butterworth filter with a -3dB point at 70kHz. Double poly-silicon capacitors and implanted resistors are used to set poles in the filter. This filter is required to have no more than 1dB attenuation at 20kHz (highest frequency of interest) and a minimum attenuation of 10dB at 180kHz. This filter precedes the switch capacitor filters which run at 200kHz.

Programmable Band Pass Switched Capacitor Filters

Two identical programmable filters are used to detect the two frequencies of interest. The Knock Frequency Filter is programmed to pass the frequency component of the engine knock. The Reference Frequency Filter is used to detect background noise at a second programmed frequency. The filter frequency is established by the characteristics of the particular engine and transducer. By subtracting the energy component of these two filters, we can detect if a knock has occurred.

The filters have a nominal differential gain of 4. Their frequency is set by program words (discussed in the Communications Protocol section). Center frequencies can be programmed from 1.22kHz to 19.98kHz, in 64 steps. The filter Q's are typically 2.4.

Balance/Gain Adjust Stage

The gains from the Knock Frequency Filter and the Reference Frequency Filter can be adjusted with respect to one another, so that the difference energies in the two bands can be compensated. This balance is achieved by feeding one of

the filters unattenuated (gain = 1) and attenuating the other. This can be adjusted with 64 different gain settings, ranging between 1 and 0.133. The signals can swing between 20 and 80 percent of V_{DD} .

Programming is discussed in the Communications Protocol section. The test/channel attenuate word is used to determine which of the two channels is attenuated and which is set to unity gain.

Active Full Wave Rectifier

The output of the filters are independently full wave rectified using switch capacitor techniques. Each of two rectifier circuits provide both negative and positive values for the knock frequency and reference frequency filter outputs. The output is able to swing from 20 to 80 percent of V_{DD} . Care was taken to minimize the RMS variations from input to output of this section.

Integrator Stage

The signals from the two rectifiers are summed and integrated together. A differential system is used to reduce noise. One system integrates the positive energy of the Knock Frequency Rectifier with respect to the positive energy of the Reference Frequency Rectifier. The second system does the integration of the negative energy value of the two rectifiers. The positive and negative energy signals are opposite phase signals. Using this technique reduces system noise.

The integrator time constant is software programmable by the Integrator Time Constant discussed in the Communications Protocol section. The time constant can be programmed from 40 μ s to 600 μ s, with a total of 32 steps. If for example, we program a time constant to 200 μ s, then with one volt difference between each channel, the output of the integrator will change by 1 volt in 200 μ s.

When integration is enabled by the rising edge of the INT/HOLD input, the output of the integrator will fall to 0.5V, within 20 μ s after the integrate line reaches the integrate state. The output of the integrator is an analog voltage.

Test Multiplexer

This circuit receives the positive and negative outputs from the two integrators, together with the outputs from different parts of the IC. The output is controlled by the fifth programming word of the communications protocol. This multiplexes the switch capacitor filter output, the gain control output and the antialiasing filter output.

Differential to Single-Ended Converter

This signal takes the output of the two integrators (through the test-multiplexer circuit) and provides a signal that is the sum of the two signals. This technique is used to improve the noise immunity of the system.

Output Buffer

This output amplifier is the same amplifier circuits as the input amplifier used to interface with the sensors. When the

output of the antialiasing filter is tested, this amplifier is in the power down mode.

Communications Protocol

The multiprocessor talks to the knock sensor via an SPI bus (MOSI). A chip select pin (\overline{CS}) is used to enable the chip, which, in conjunction with the SPI clock (SCK), moves in the eight bit programming word. Five different programming words are used to set gains, frequency response, integrator constants, test mode, channel select and test mode conditions.

With chip select (\overline{CS}) going low, on the next rising edge of the SPI clock (SCK), data is latched into the IC. The data is shifted with the most significant bit first and least significant bit last. Each word is divided into two parts: first the address and then the value. Depending on the function being controlled, the address is 2 or 3 bits, and the value is either 5 or 6 bits long. During the hold mode of operation, all five programming words can be entered into the IC, but during the integrate time any single byte may be entered but will not be acted upon until the start of the next hold period. The integration or hold mode of operation is controlled by the INT/HOLD input signal.

Programming Words

1. Reference Filter Frequency: Defines the center frequency of the Reference Filter in the system. The first 2 bits are used for the address and the last 6 bits are used for its value. 01FFFFFF Example: 01001010 would be the reference filter (01 for the first two bits) at a center frequency of 1.78kHz (bit value in Table 2 of 10).
2. Knock Filter Frequency: Defines the center frequency of the Knock Filter in the system. The first 2 bits are used for the address and the last 6 bits are used for its value. 00FFFFFF Example: 00100111 would be the knock filter frequency (00 for the first two bits) at a center frequency of 6.37kHz (bit value in Table 2 of 39).
3. Balance Control: Defines the ratio of the gain of the knock band center frequency to that of the reference band center frequency. This role can be reversed by the value of C_A in the fifth programming bit, as explained in 5, Test/Channel Select/Channel Attenuate Control. The first 2 bits are used for the address and the last 6 bits for its value. 10GGGGGG Example: 10010100 would be the balance control (10 for the first two bits) with an attenuation of 0.514 (bit value in Table 2 of 20.) Depending on the value of C_A in the fifth word this would apply to the reference or the knock gain section.
4. Integrator Time Constant: Defines the Integration Time Constant for the system. The first 3 bits are used for the address and the last 5 bits for the value. 110TTTTT Example: 11000011 would be the integrator time constant (110 on for the first 3 bits) and an integration constant of 55 μ s (bit value of 3 in Table 2).
5. Test/Channel Select/Channel Attenuate Control: This word serves several purposes. By looking at the structure, 111T_AT_BT_CC_SC_A, the first 3 bits are used for the address, and the last 5 bits are used for the value. The options are:

- If CS is "0" channel "0" is selected. If CS is "1" channel "1" is selected.
- If C_A is "0" attenuation applies to the knock filter. If C_A is "1" attenuation applies to the reference filter.
- During the test mode ($\overline{\text{TEST}}$ input is a low level), if T_A is "0" all sections get their input from the output of the antialiasing filter input. This input can come from either the output of channel "0" amplifier or channel "1" output depending upon the state of the C_S bit. If T_A is "0" the input amplifiers are powered down. If T_A is set to "1" during the test mode the chip is configured in its normal operating state, getting inputs to all sections from previous sections.
- Combinations of T_A, T_B and T_C are used to test the different analog parts of the circuit. Table 1 shows these combinations. All blocks except for the antialiasing filter are sampled via the differential to single ended converter in the test mode.

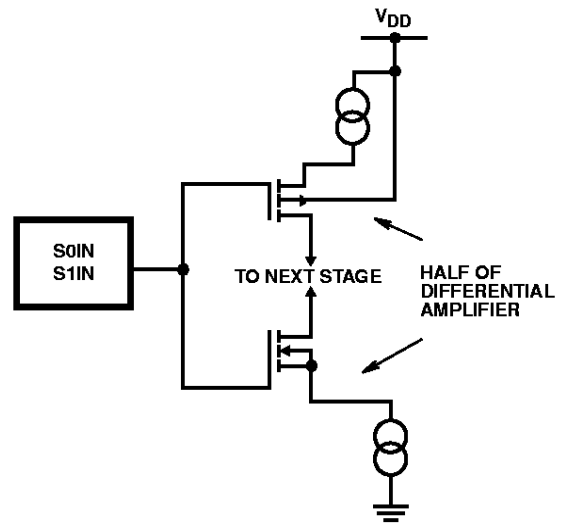

FIGURE 4A. S0IN AND S1IN INPUT CIRCUIT

TABLE 1. SHOWING PROGRAMMING IN THE TEST MODE

TEST PIN 14	T _A	T _B	T _C	C _{HS}	ANALOG OUTPUT FROM:
0	0	0	0	0	Knock Rectifier
0	0	0	0	1	Reference
0	0	0	1	0	Knock Filter
0	0	0	1	1	Reference Filter
0	0	1	0	0	Antialias Filter(1)
0	0	1	0	1	Antialias Filter(1)
0	0	1	1	0	Integrator
0	0	1	1	1	Integrator
0	1	0	0	0	Knock Rectifier
0	1	0	0	1	Reference
0	1	0	1	0	Knock Filter
0	1	0	1	1	Reference Filter
0	1	1	0	0	Antialias Filter(1)
0	1	1	0	1	Antialias Filter(1)
0	1	1	1	0	Integrator
0	1	1	1	1	Integrator
1	x	x	x	x	Integrator

NOTE:

1. All Test function blocks have their outputs buffered by the differential to single ended converter. Their outputs are available at the INTOUT pin 4 of the chip. In the case of the antialias filter test function, the output is taken directly to the INTOUT pin 4 of the chip.

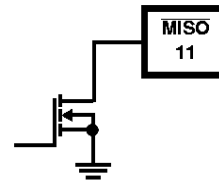

FIGURE 4B. $\overline{\text{MISO}}$ OUTPUT OF SPI DATA BUS IS AN OPEN DRAIN TRANSISTOR

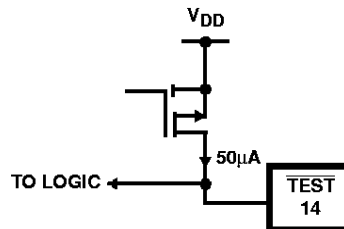

FIGURE 4C. TEST PMOS TRANSISTOR HAS EQUIVALENT CURRENT PULLUP CAPABILITY OF A 50k TO 200k RESISTOR

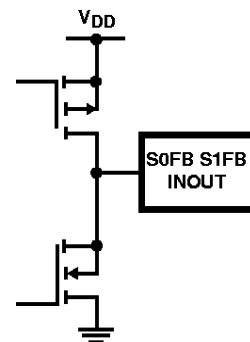

FIGURE 4D. S0FB, S1FB AND INOUT EQUIVALENT OUTPUT CIRCUITS

FIGURE 4. INTERFACE CIRCUITS

HIP9010

TABLE 2. FREQUENCY, BALANCE / GAIN AND INTEGRATOR TIME CONSTANT SETTINGS

BIT VALUE PER FUNCTION	FREQUENCY kHz	OUTPUT LEVEL	TIME CONSTANT μs	BIT VALUE PER FUNCTION	FREQUENCY kHz	OUTPUT LEVEL
0	1.22	1.000	40	32	4.95	0.360
1	1.26	0.960	45	33	5.12	0.346
2	1.31	0.923	50	34	5.29	0.333
3	1.35	0.889	55	35	5.48	0.320
4	1.40	0.857	60	36	5.68	0.309
5	1.45	0.828	65	37	5.90	0.298
6	1.51	0.800	70	38	6.12	0.288
7	1.57	0.774	75	39	6.37	0.279
8	1.63	0.750	80	40	6.64	0.270
9	1.71	0.727	90	41	6.94	0.262
10	1.78	0.706	100	42	7.27	0.254
11	1.87	0.686	110	43	7.63	0.247
12	1.96	0.667	120	44	8.02	0.240
13	2.07	0.649	130	45	8.46	0.234
14	2.18	0.632	140	46	8.95	0.228
15	2.31	0.615	150	47	9.50	0.222
16	2.46	0.600	160	48	10.12	0.217
17	2.54	0.576	180	49	10.46	0.208
18	2.62	0.554	200	50	10.83	0.200
19	2.71	0.533	220	51	11.22	0.193
20	2.81	0.514	240	52	11.65	0.186
21	2.92	0.497	260	53	12.10	0.179
22	3.03	0.480	280	54	12.60	0.173
23	3.15	0.465	300	55	13.14	0.168
24	3.28	0.450	320	56	13.72	0.163
25	3.43	0.436	360	57	14.36	0.158
26	3.59	0.424	400	58	15.07	0.153
27	3.76	0.411	440	59	15.84	0.149
28	3.95	0.400	480	60	16.71	0.144
29	4.16	0.389	520	61	17.67	0.141
30	4.39	0.379	560	62	18.76	0.137
31	4.66	0.369	600	63	19.98	0.133

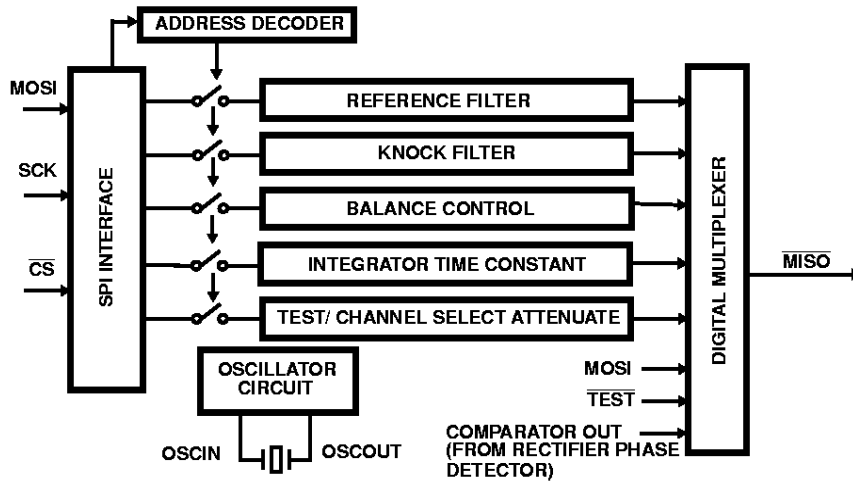

FIGURE 5. DIGITAL BLOCK DIAGRAM

The digital block diagram shows the programming flow of the chip. An eight bit word is received at the $\overline{\text{MISO}}$ port. Data is shifted in by the SCK clock when the chip is enabled by the $\overline{\text{CS}}$ pin. The word is decoded by the address decoding circuit, and the information is directed to one of 5 registers. These registers control:

1. Reference knock filter frequency.
2. Knock filter frequency.
3. Balance control or attenuation of one channel with respect to the other.
4. Integration time constant of the sum of the two channels.
5. One of 3 functions.
 - a) test conditions of the part.
 - b) channel select to one of two sensors.
 - c) channel to be attenuated.

A crystal oscillator circuit is provided. The chip requires a 4MHz crystal to be connected across OSCIN and OSCOUT pins.

In the test mode, use the digital multiplexer to output one of the following signals:

1. Contents of one of the five registers in the chip.
2. Inverted signal of the MOSI pin.
3. Voltage of an internal comparator used to rectify the analog signal.

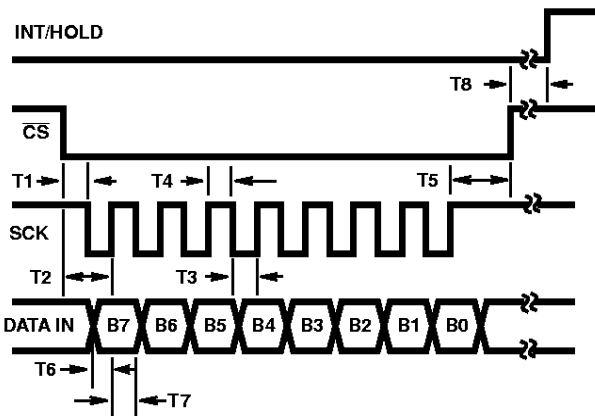

FIGURE 6. SPI TIMING

TABLE 3. SPI TIMING REQUIREMENTS

DESCRIPTION	UNITS
T1 min. time from $\overline{\text{CS}}$ falling edge to SCK falling edge.	10ns
T2 min. time from $\overline{\text{CS}}$ falling edge to SCK rising edge.	80ns
T3 min. time for the SCK low.	60ns
T4 min. time for the SCK high.	60ns
T5 min. time from SCK rise after 8 bits to $\overline{\text{CS}}$ rising edge.	80ns
T6 min. time from data valid to rising edge of SCK.	60ns
T7 min. time for data valid after the rising edge of the SCK.	10ns
T8 min. time after $\overline{\text{CS}}$ rises until INT/HOLD goes high.	8 μ s

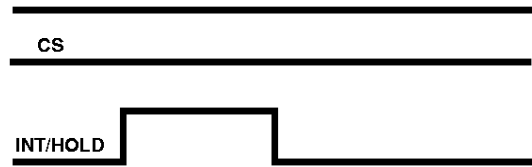

FIGURE 7. POWER UP SEQUENCE

Upon power up, chip requires that the INT/ $\overline{\text{HOLD}}$ pin is toggled. If this is not done then it is important to note, that only the first result and SPI data bytes sent after power up will not be valid. Any subsequent chip operation will then be performed correctly.

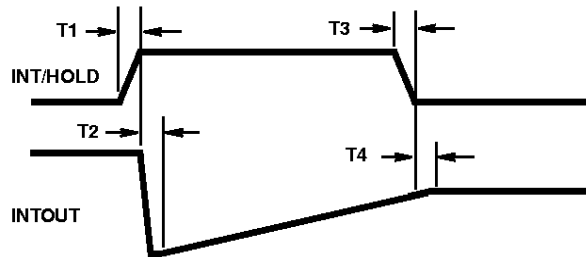

FIGURE 8. INTEGRATOR TIMING

TABLE 4. INTERGRATE/ $\overline{\text{HOLD}}$ TIMING REQUIREMENTS

DESCRIPTION	UNITS
T1 max. rise time of the INT/ $\overline{\text{HOLD}}$ signal.	45ns
T2 max. time after INT/ $\overline{\text{HOLD}}$ rises for the INTOUT to begin to intergrate.	20 μ s
T3 max. fall time of INT/ $\overline{\text{HOLD}}$ signal.	45ns
T4 typical time after INT/ $\overline{\text{HOLD}}$ goes low before chip goes into hold state.	20 μ s
T5 minimum INT/ $\overline{\text{HOLD}}$ time during power up sequence.	1 μ s

Test Multiplexer

This circuit receives the positive and negative outputs out of the two integrators, together with the outputs from different parts of the chip. The output is controlled by the fifth programming word of the communications protocol. This multiplexes the switch capacitor filter output, the gain control output as well as the antialias output.

Differential to Single-ended Converter

This signal takes the output of the two integrators (through the test multiplexer circuit) and provides a signal that is the sum of the two signals. This technique is used to improve the noise immunity of the system.

Output Buffer

This output amplifier is the same as the input amplifier used to interface to the sensors. For test purposes when we look at the output of the antialias filter, the input amplifiers are in the power down mode.